

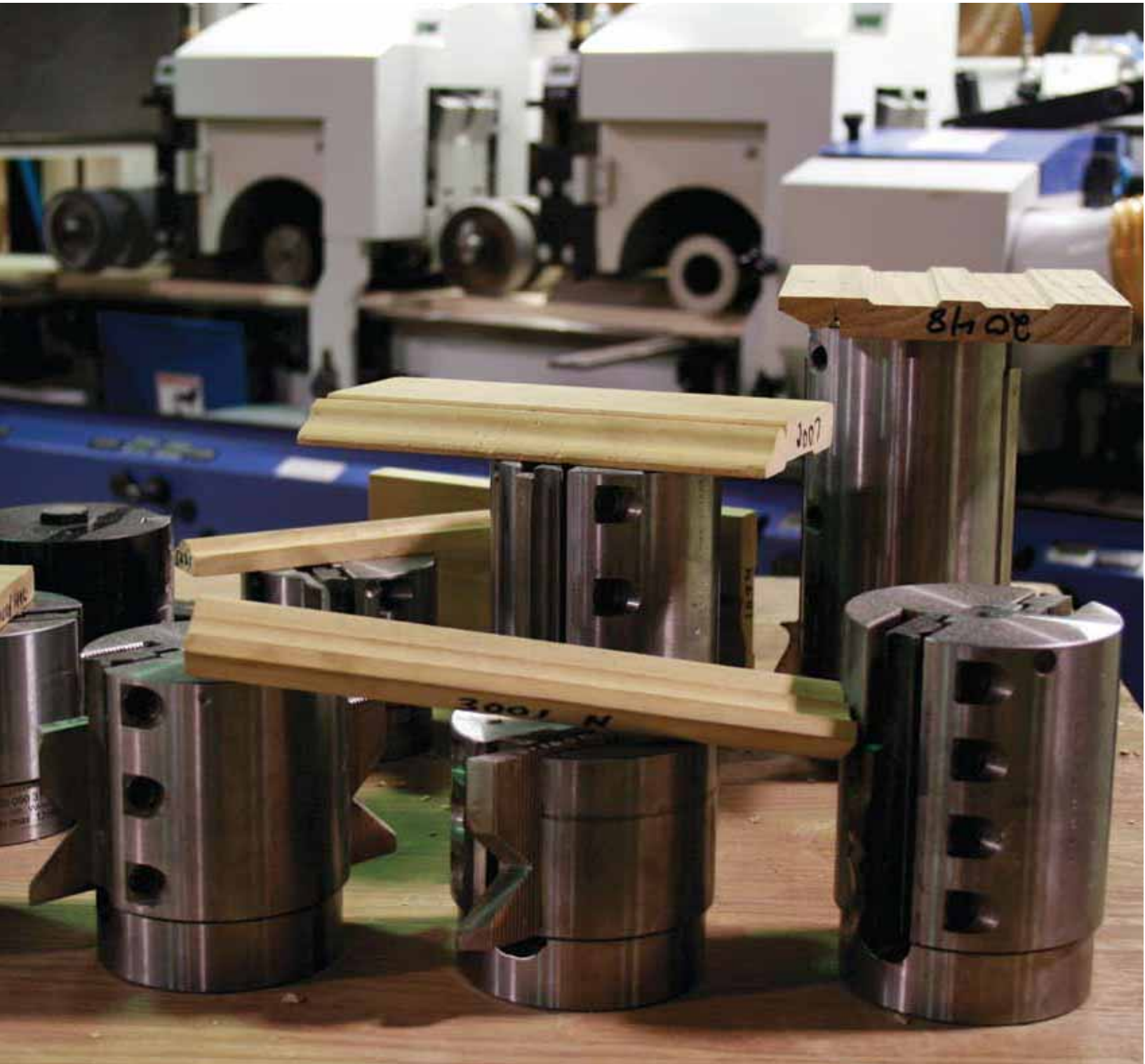

Mouldings One

Catalogue of Profile Drawings



Since 1958, The Hardwood Lumber Company has expanded from a small sawmill, selling rough lumber, to a large manufacturing facility that produces a wide variety of quality wood products. Mouldings One, a division of The Hardwood Lumber Company, specializes in the milling of the highest quality custom architectural millwork and the distribution of MDF mouldings, interior doors, stair parts, and door hardware.

In 2008, Mouldings One invested in a state-of-the-art moulder and profile sander to ensure unmatched quality and consistency.



8003

8022

8025

8028

8042

8043

8045

8047

8048

8048

8061

8063

8064

Wood Spec

Dentist #3

Jamb

8058

8058

8098

8068

9006

8158

9111

Architectural Styles	10-11	Shoe	94
Wood Species	14-15	Shoe Rail and Fillet	107
		Small Mold	92-93
Stock Base	19	Tongue and Groove	133-135
Stock Base Cap	23	Transition Mold	141-143
Stock Casing	18	Window Sill	136-137
Stock Chair Rail	21		
Stock Outside Corner	23	stock MDF Base	149
Stock Cove	21	stock MDF Base Cap	151
Stock Crown	20	stock MDF Casing	148
Stock Door Stop	23	stock MDF Chair Rail	151
Stock Handrail	24-25	stock MDF Crown	150
Stock Nosing	27	stock MDF S4S	147
Stock Panel Mold	23		
Stock S4S	16-17	MDF Architrave	161
Stock Shoe	22	MDF Base	155-156
Stock Shoe Rail and Fillet	25	MDF Base Cap	161
Stock Small Mold	22	MDF Casing	152-154
Stock Window Sill	26	MDF Chair Rail	160
Stock Miscellaneous	26	MDF Crown	157-159
		MDF Wainscot	161
		MDF Window Sill	160
Back Band	108-112		
Bar Rail	132		
Base	54-70	Customized Details and Design Ideas	
Base Cap	100-102	Arched Casing and Jambs	164
Casing	28-53	Backband and Casing	188-191
Chair Rail	89-91	Base and Crown Corner Blocks	170-171
Outside Corner	103	Beams	176-179
Cove	88	Crown Build-up	172-175
Crown	71-87	Dentil Mould	169
Door Stop	99	Door and Window Headers	186-187
Handrail	103-107	Mantles	168
MDF	144-161	Rosette and Plinth Blocks	165-167
Miscellaneous	113-127	Wainscoting	180-185
Nosing	138-140		
Panel Mold	95-98	Policies	192-195
Plinth Block	128-132	Glossary of Moulding Terms	196-199



asing
LL SCALE

ING +
CAL

OPEN
FAMILY

SQUARE
ENGAGED
COLUMN

For 11"

(Show
1/4"
Squaring)



Individual Creativity

You are invited to visit our showroom and select from hundreds of our available wood moulding samples. Any unique, deeply personal vision you have, ranging from traditional to contemporary, can be created from almost unlimited design combinations.

Custom Mouldings

If you wish to create a moulding that is not found in our collection, our workshop can produce custom tooling to precisely match sketched drawings, architectural blueprints or existing wood samples.



Environment

The Hardwood Lumber Company is committed to sustainable logging. All of the domestic wood species are harvested from the Northern Appalachian region, which produces more trees than are cut down. The exotic species are imported from properly managed forests throughout the world.



Architectural Styles

Our large selection of mouldings enables architects and designers to find a look that complements any distinct style of architecture. We offer a CD with a photo gallery of millwork featuring various architectural styles and profile drawings in CAD and JPEG. You can also visit our gallery at mouldingsone.com.

Art Deco - a popular design style during the 1920's and 1930's characterized by bold outlines, geometric and zigzag forms, coupled with the use of new materials

Arts & Crafts - a European and American design that originated during the late 19th and early 20th centuries featuring low-pitched, symmetrical roofs, masonry porches, decorative eaves, and built-in interior cabinetry

Colonial - an 18th and 19th century American style influenced by English, Dutch, German, and French settlers; this style often has white paint, panel doors, a center hall plan, and a doric portico

Farmhouse - a design closely connected to our country's rich historical past characterized by covered porches, dormer windows, and white exterior paint

High Country - an outdoor inspired design constructed from natural materials featuring log siding, exposed timbers, river-rock masonry, and a split-shingle roof

Modernist - a design from the early 1920's inspired by the minimalist approach with clean lines, round windows, and multiple, flat roof lines with horizontal railings

New European/French Country - a classical French design reflecting both formality and country living of the French culture recognizable by steeply pitched roof lines, dormer windows, symmetrical floor plans and arched entries

Southwestern - a design echoing early Spanish Colonial monasteries and missions of the 17th century, commonly using red clay tile roofing and stucco

Traditional - practical and functional, often associated with New England Cape Cod and Americana styles identified by basic floor plans, gabled roofs, and dormer windows

Tudor - inspired by English manor homes and French country estates, noted for its use of half timbers against stucco or masonry walls and arched entries

Tuscan - a Roman and Florentine design popularized during the early 20th century recognizable by the use of natural materials, rich textures, and earthtone colors

Victorian - a romantic style that arose between the 1830's and early 1900's that is often associated with gingerbread detailing, varying wall textures, shingles, and decorative brickwork



Our Expanding Collection

The following pages contain most of the profile drawings from our continuously growing collection. All drawings are accurate, full-size cross-sections of each moulding.



Brazilian Cherry

Hardness 2350



Ash

Hardness 1320



Lyptus

Hardness 2228



Beech

Hardness 1300



Santos Mahogany

Hardness 2200



Red Oak

Hardness 1290



Hickory/Pecan

Hardness 1820



Birch

Hardness 1260



Hard Maple

Hardness 1450

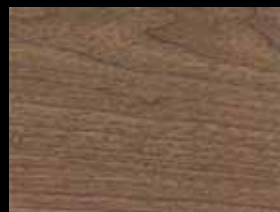

Walnut

Hardness 1010

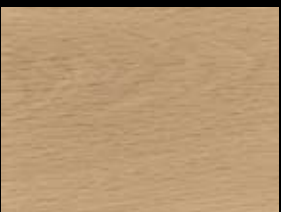

White Oak

Hardness 1360



Sassafras

Hardness 1000



Cherry

Hardness 950



Knotty Alder

Hardness 590



Curly Maple

Hardness (see Soft or Hard Maple)



Poplar

Hardness 540



Soft Maple

Hardness 950



Basswood

Hardness 410

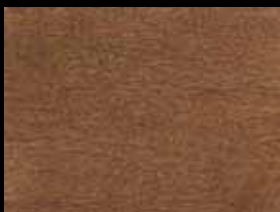

Honduras Mahogany

Hardness 800



Knotty Pine

Hardness 380



African Mahogany

Hardness 800



Clear Pine

Hardness 380



Spanish Cedar

Hardness 600

S4S

S4S (surfaced four sides) is dimensioned lumber that has all the faces and edges moulded and one face sanded smooth. To the right are the sizes inventoried in Poplar, Maple, and Red Oak. Additional thicknesses, sizes, and hardwood species are available.

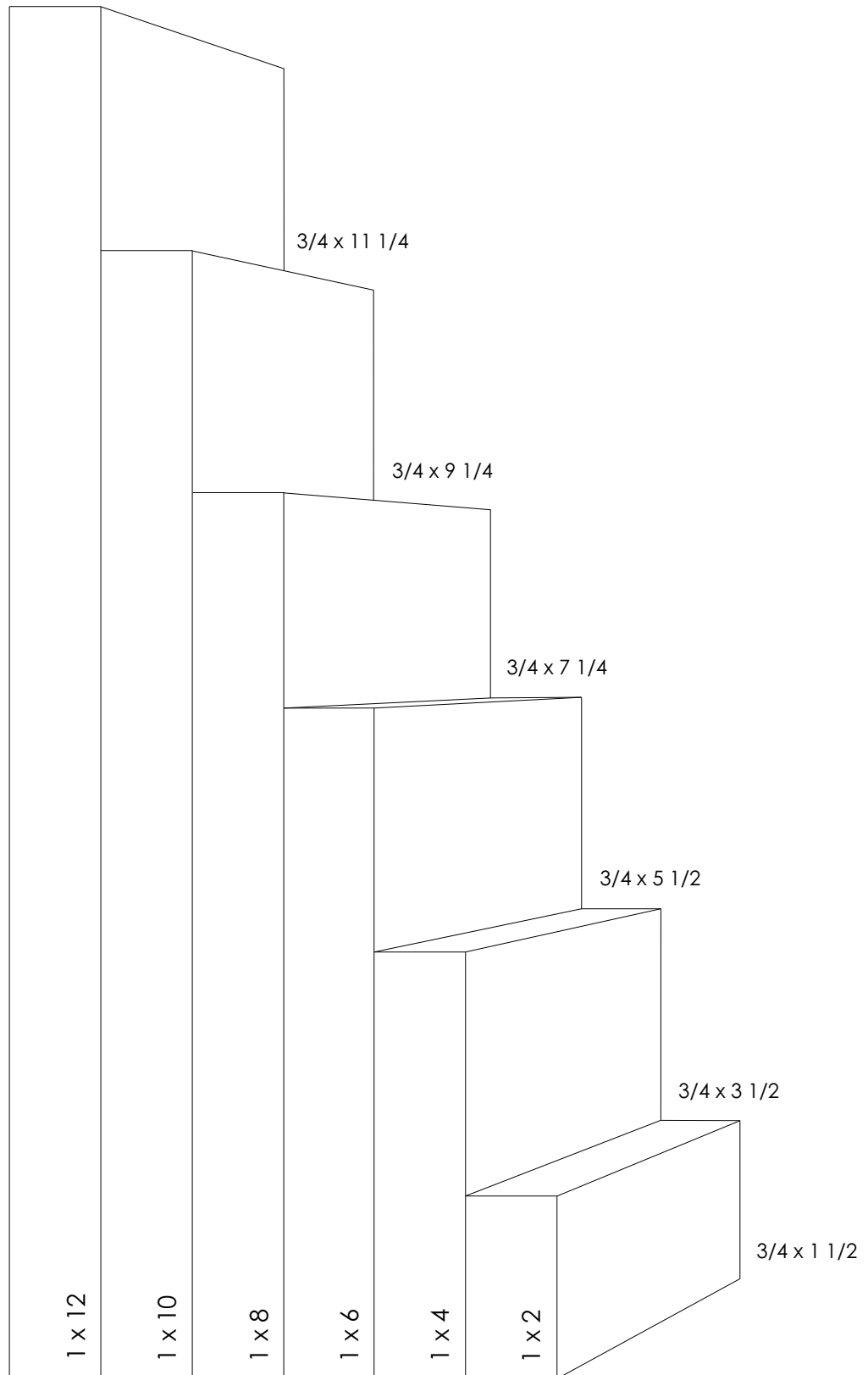

stock Casing

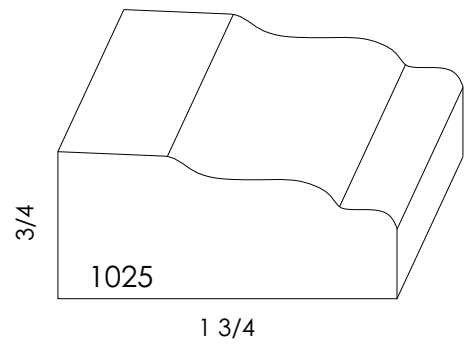
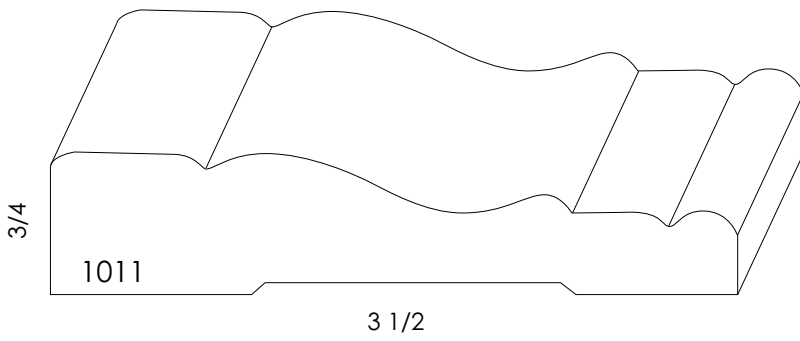
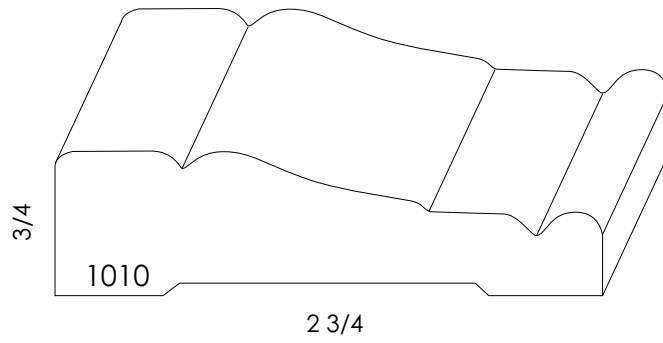
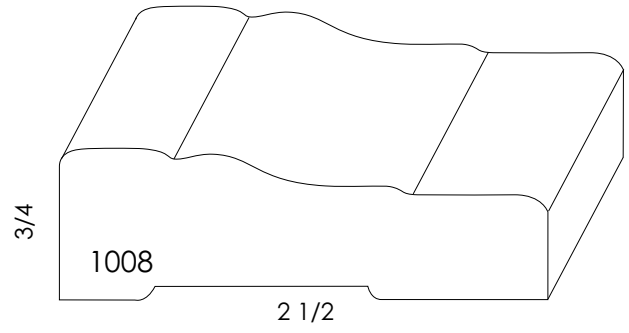
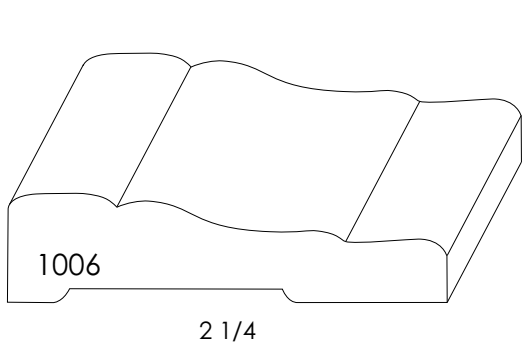
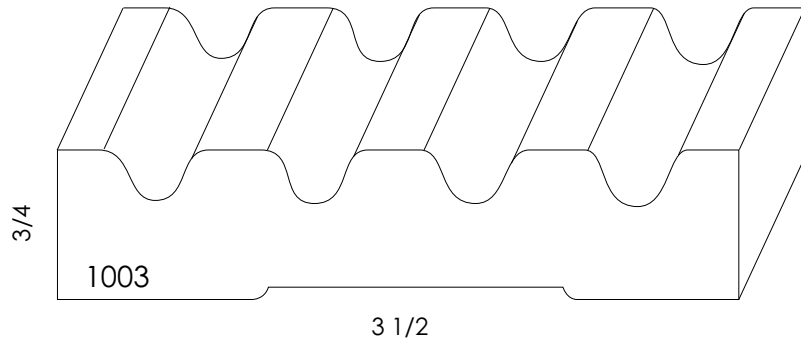

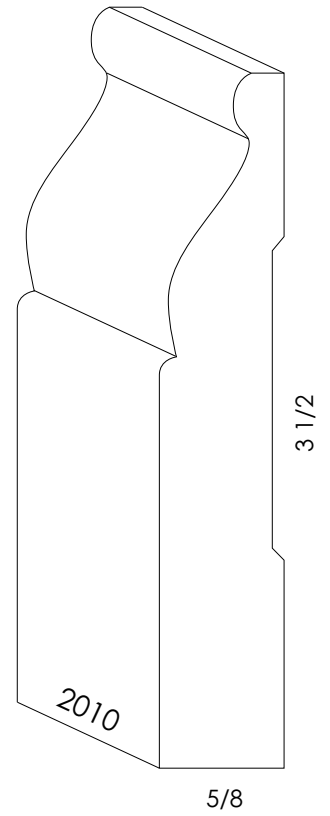
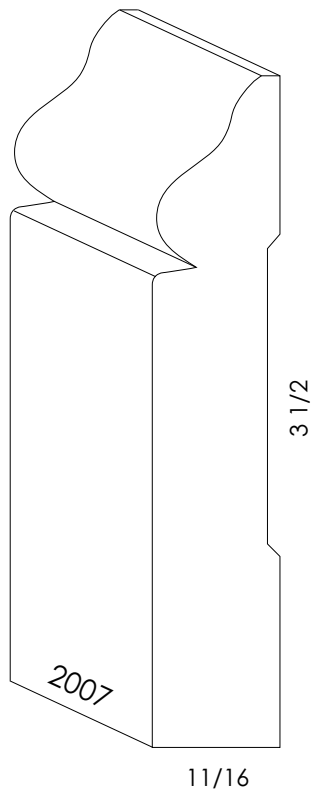
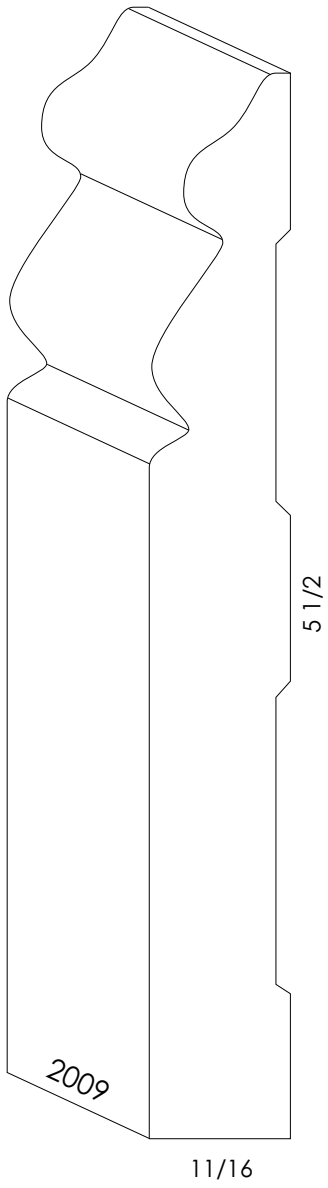
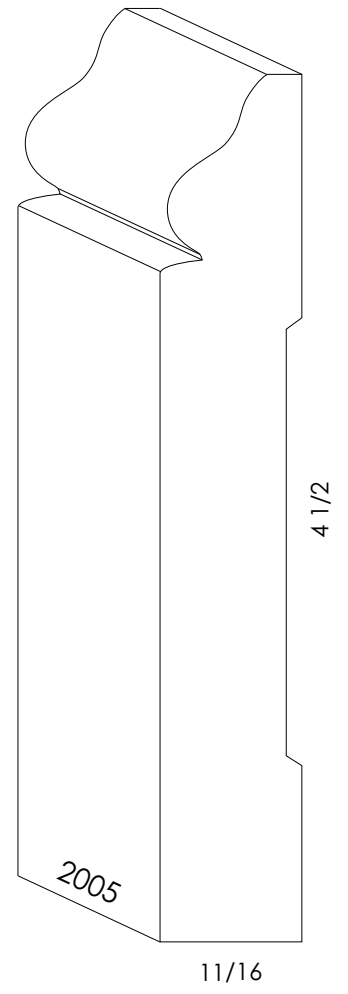
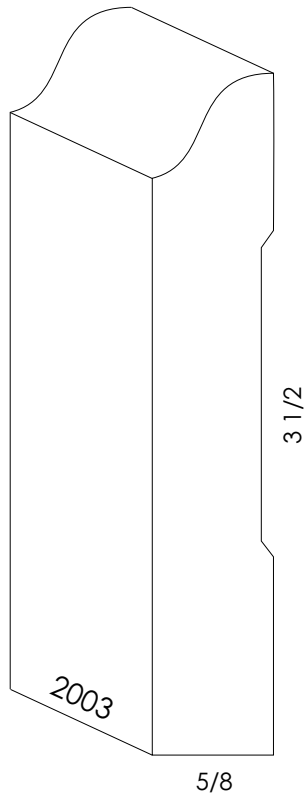
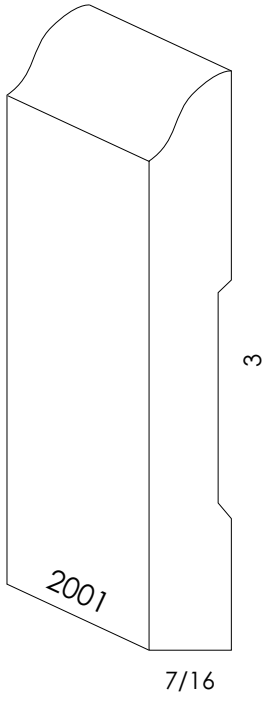

stock Base

stock Crown

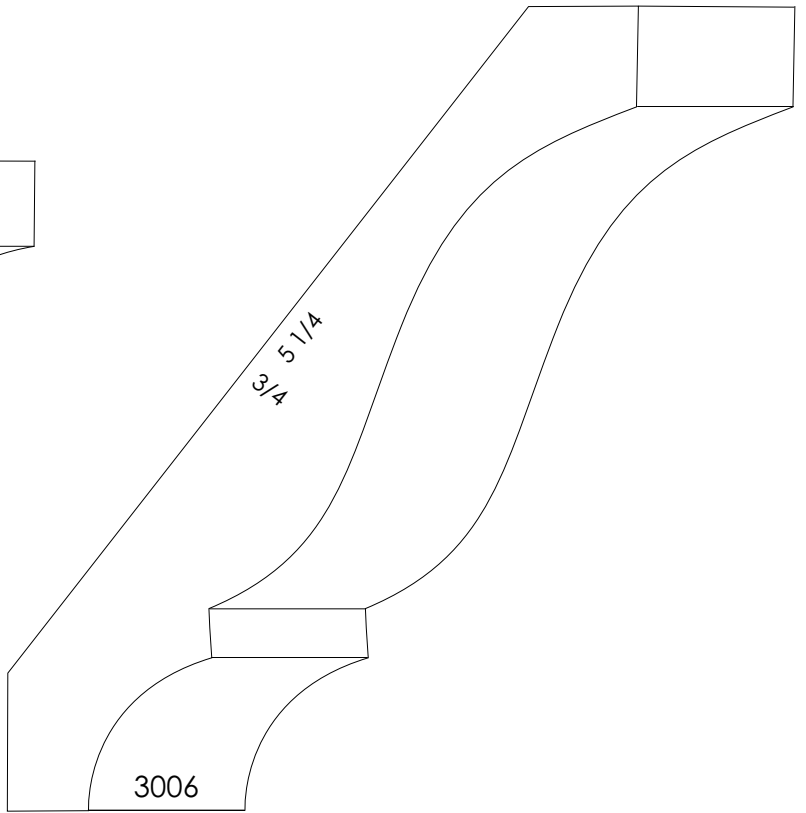
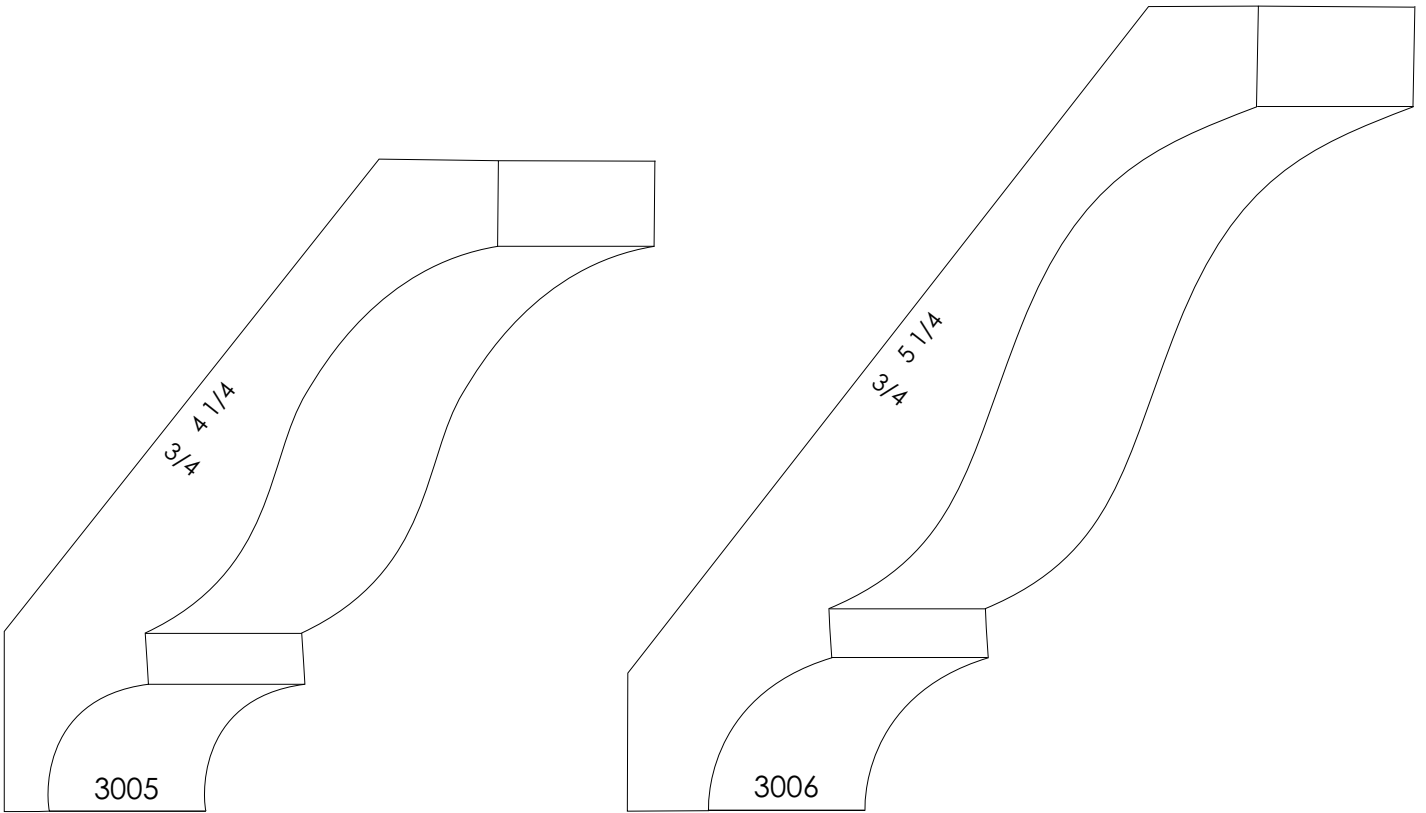
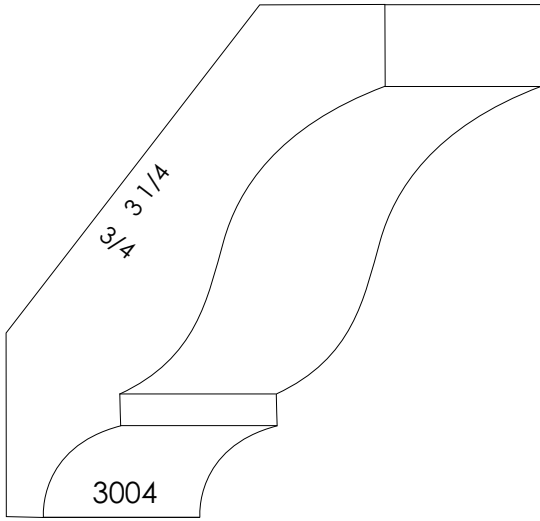
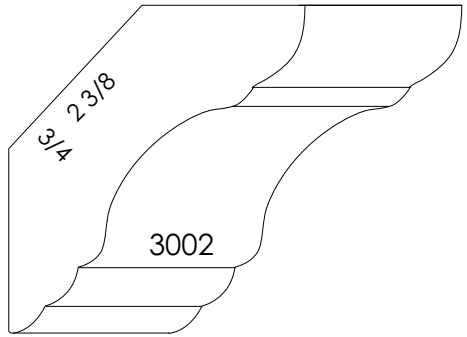
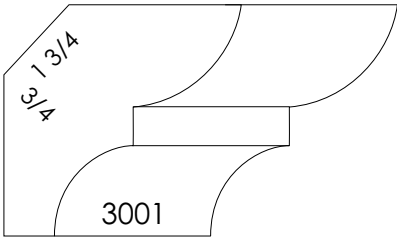

stock Cove

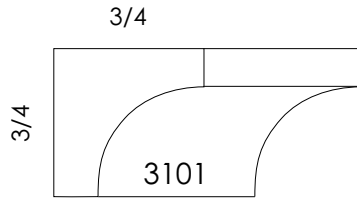

stock Chair Rail

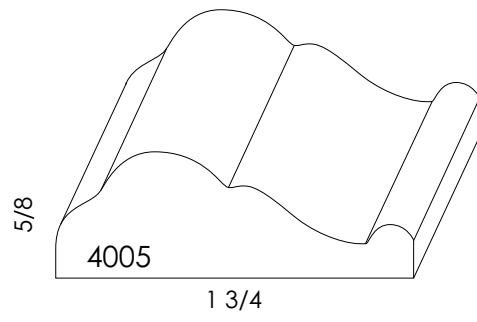
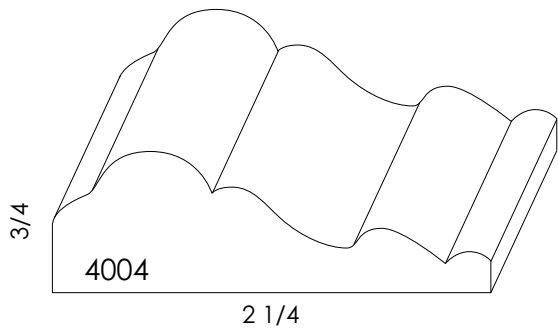
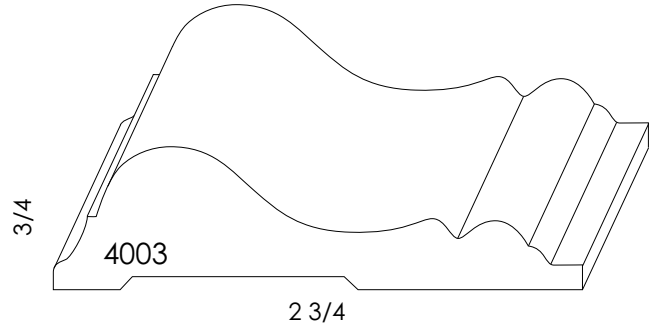
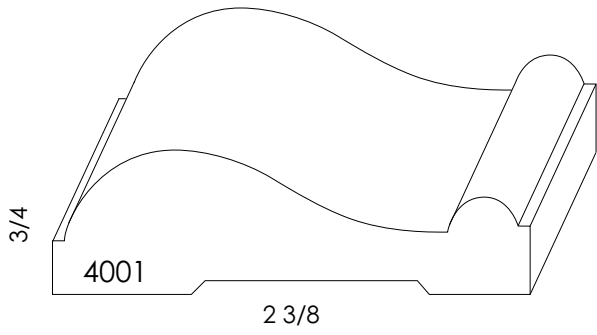

stock Small Mold

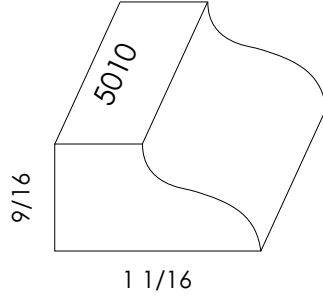
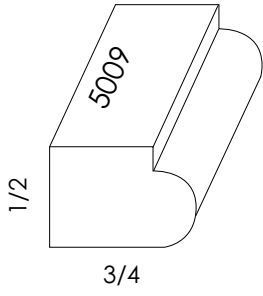
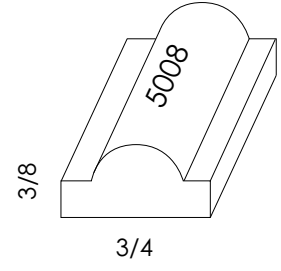
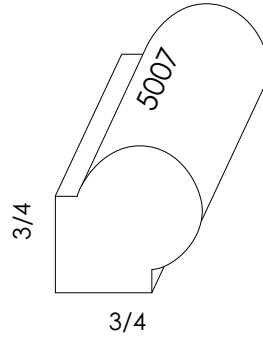
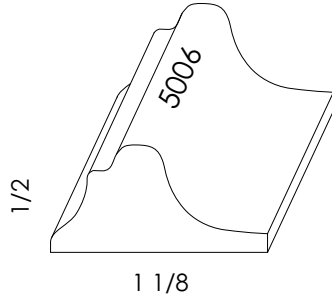
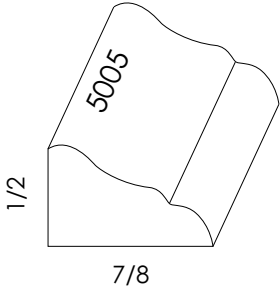
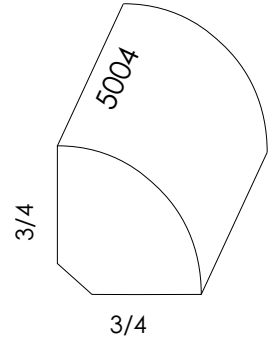
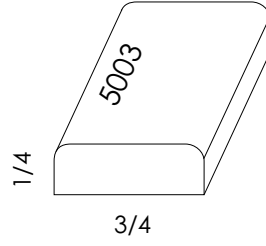
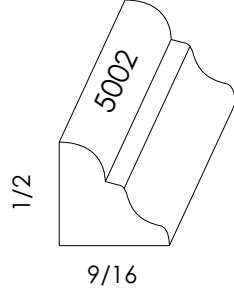
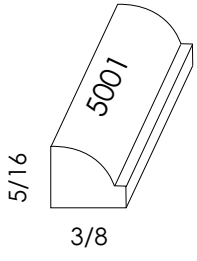

stock Shoe

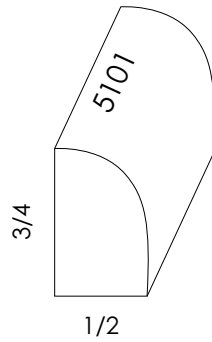

stock Panel Mold

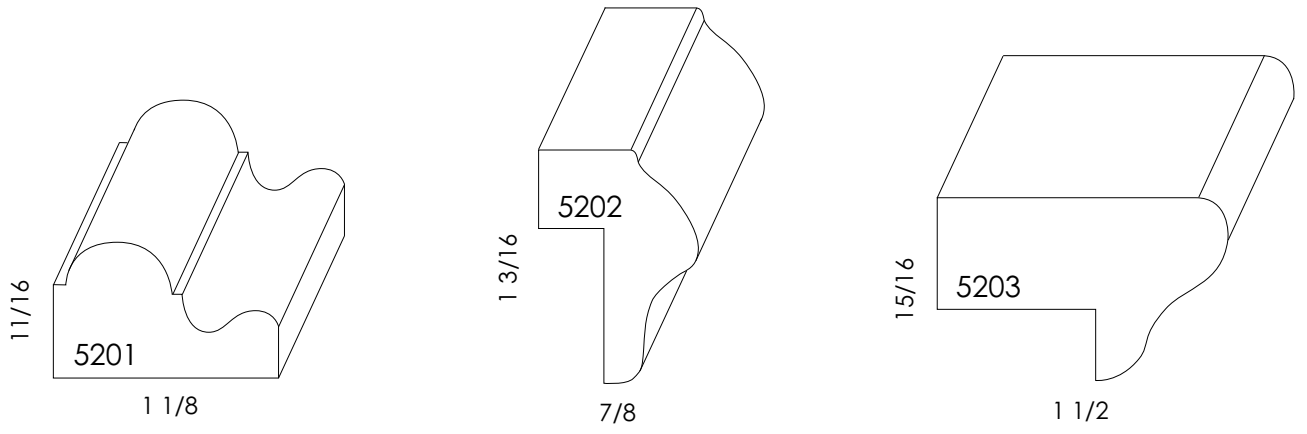

stock Door Stop



stock Base Cap

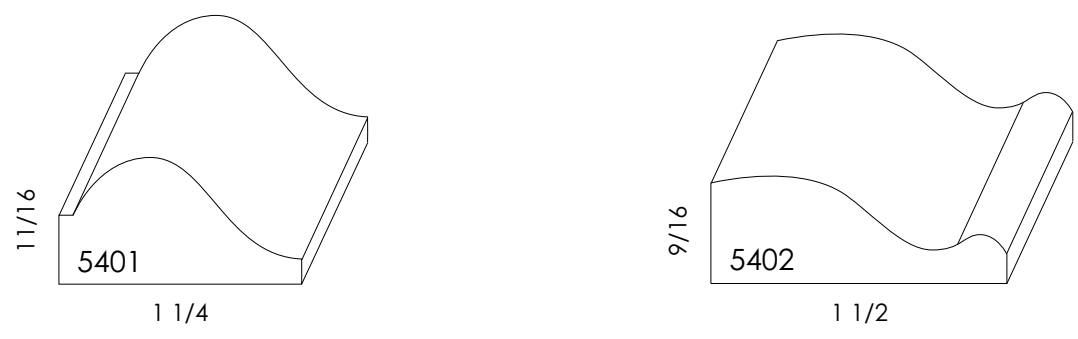

stock Outside Corner

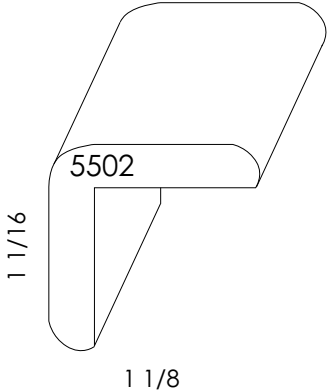
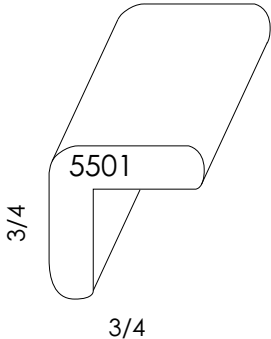

stock Handrail

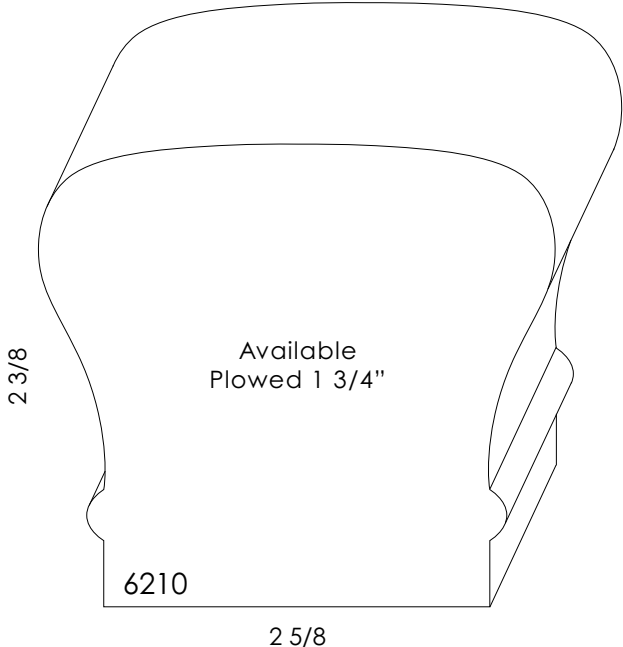
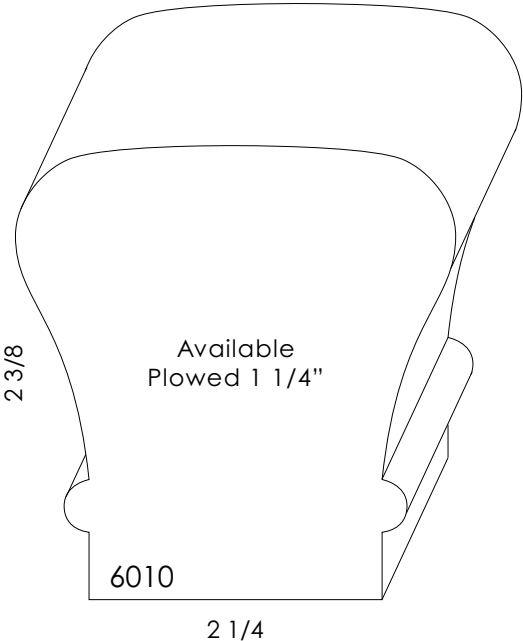

stock Handrail

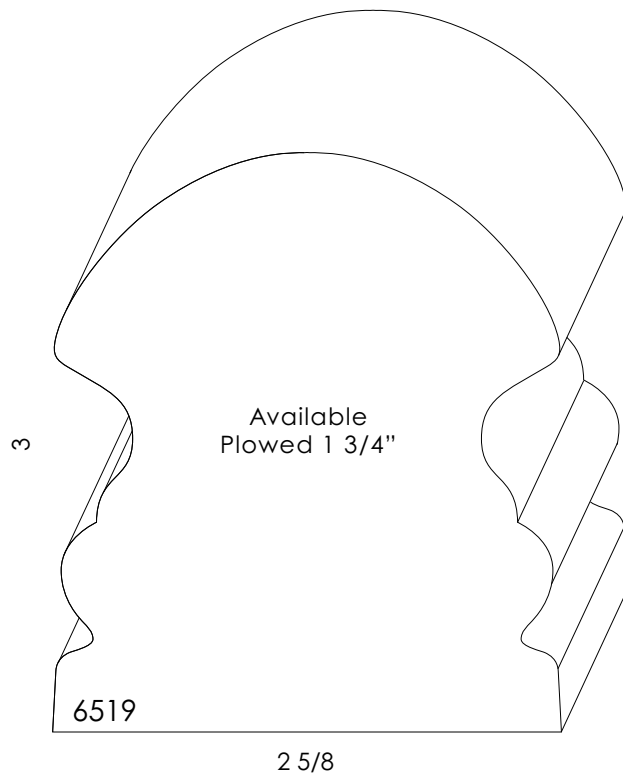

stock Shoerail

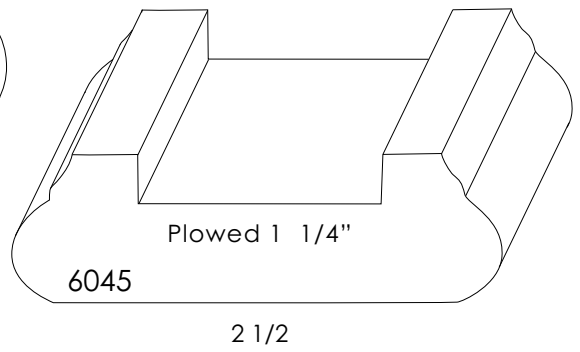
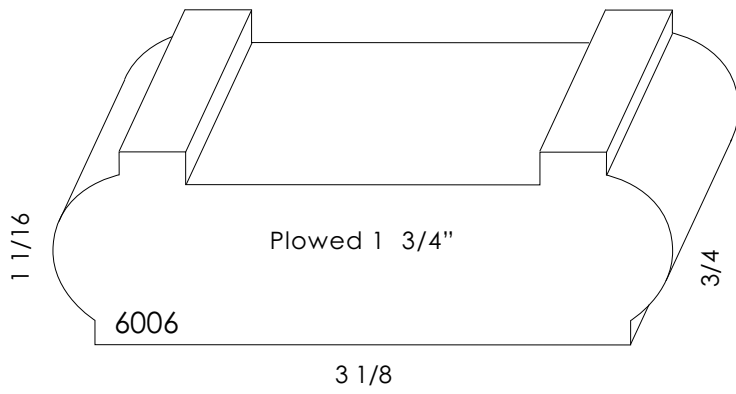

stock Fillel

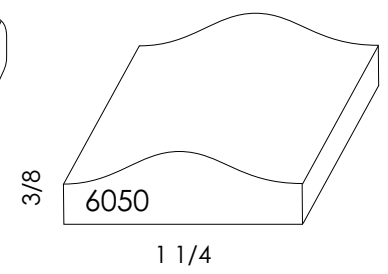
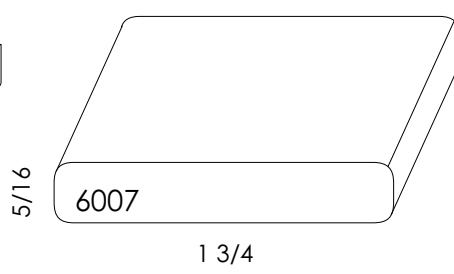
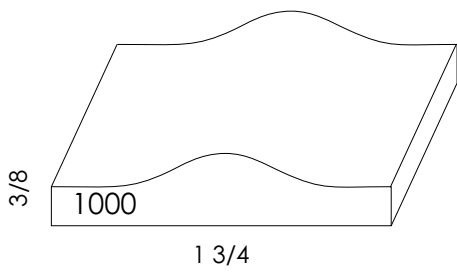

stock Miscellaneous

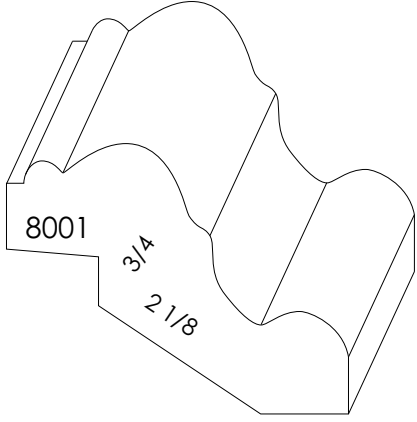

stock Window Sill

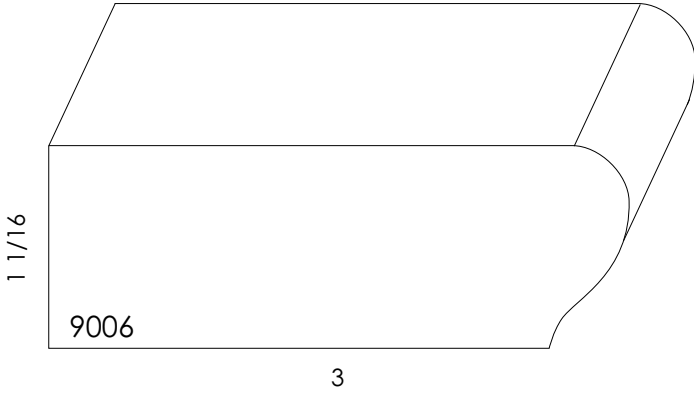
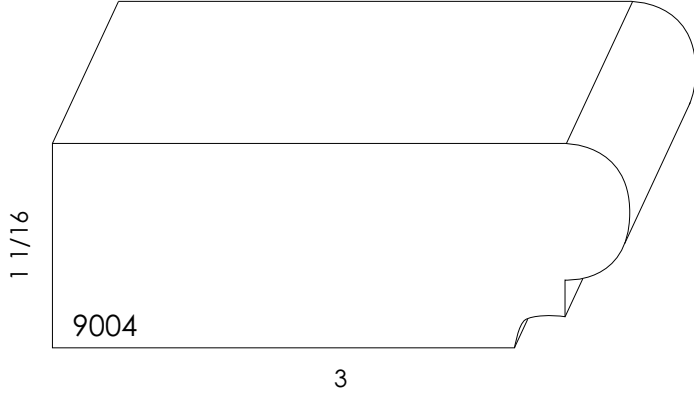

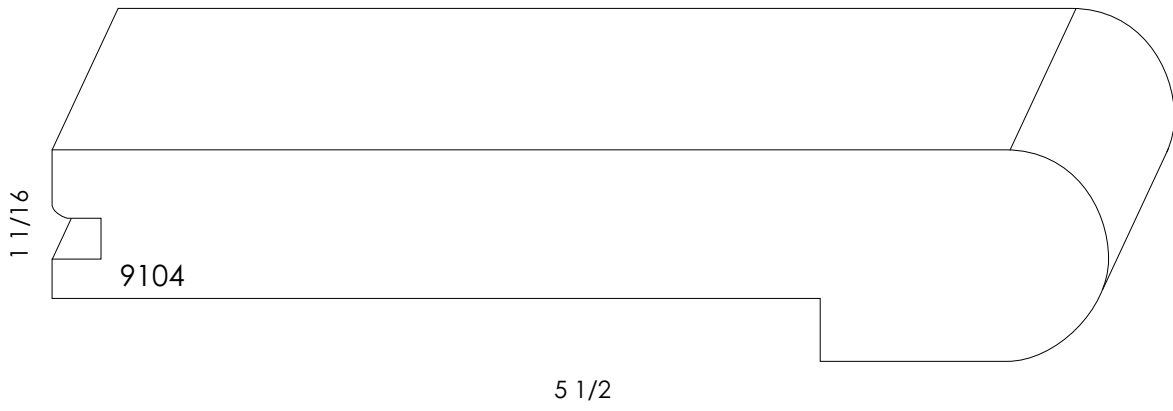
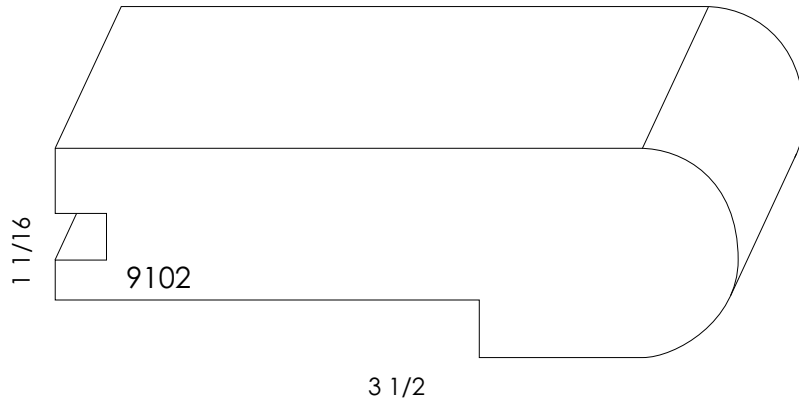

Casing

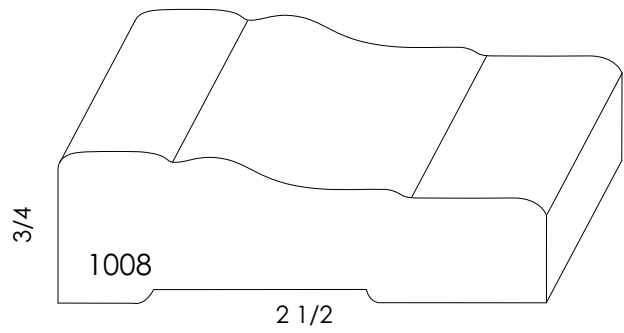
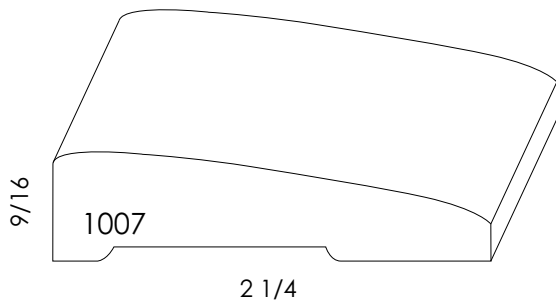
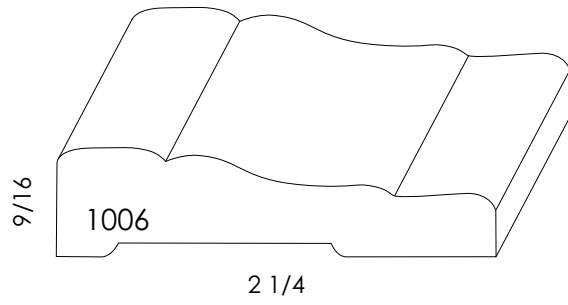
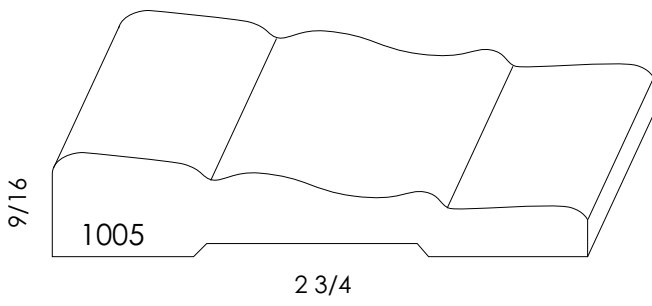
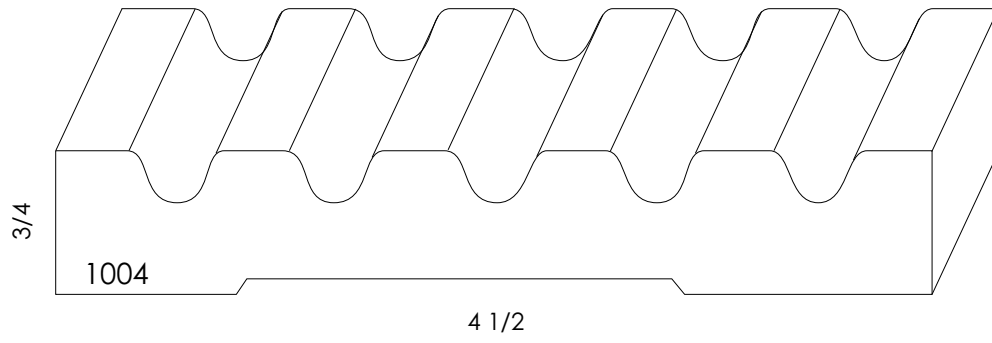
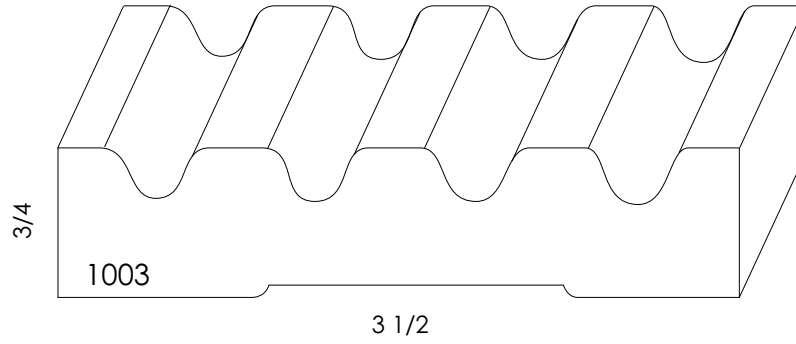
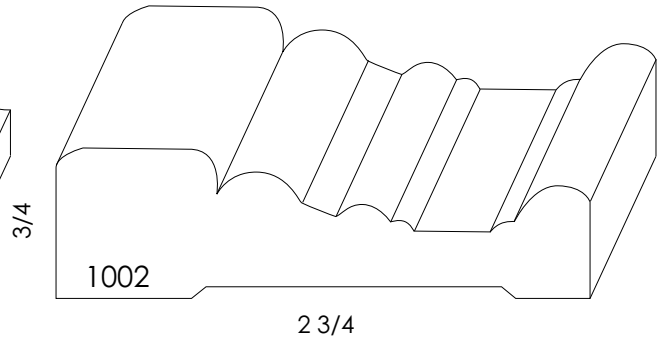
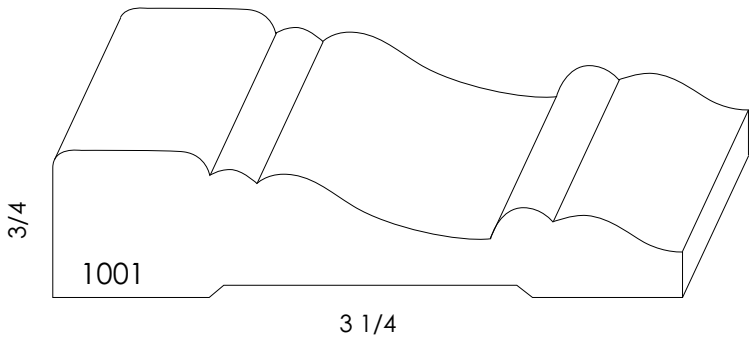

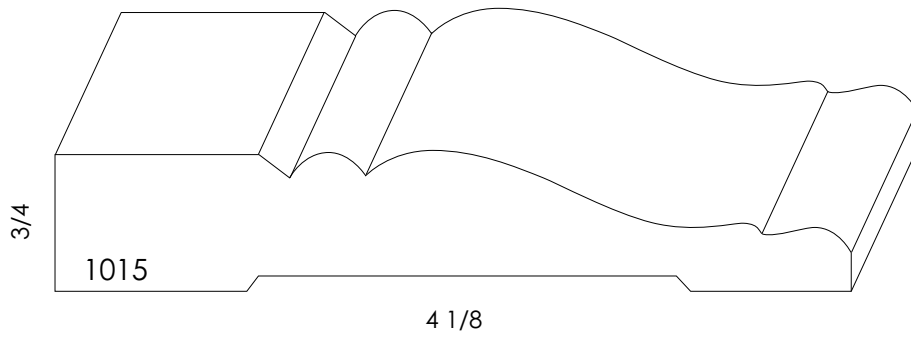
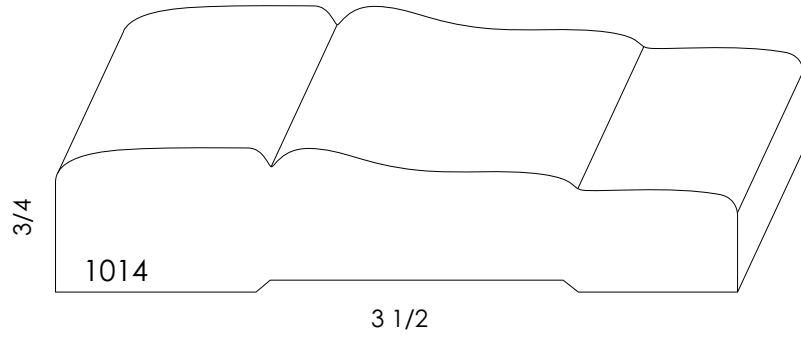
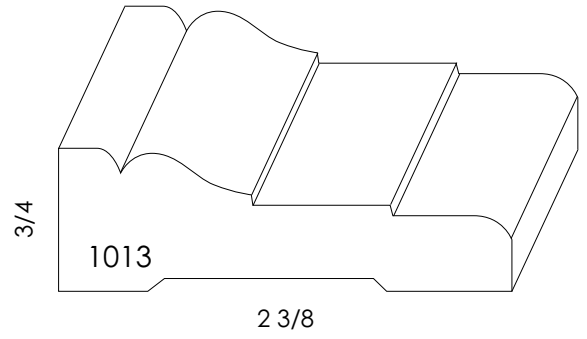
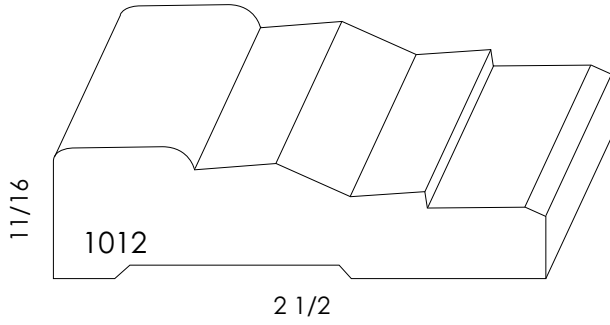
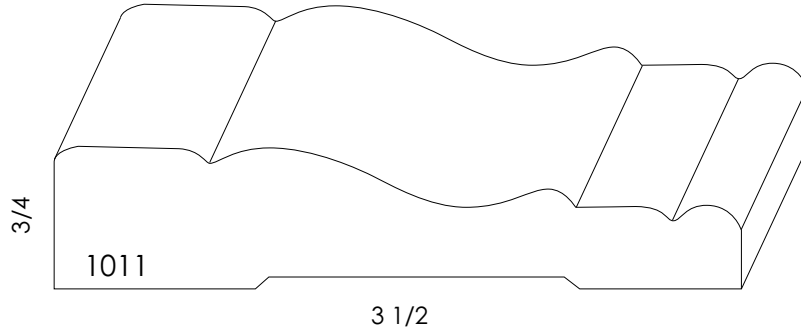
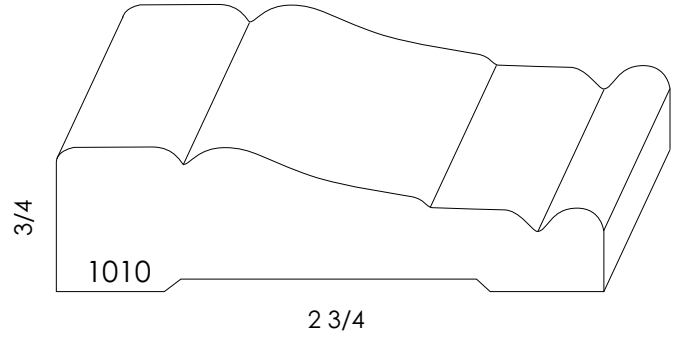
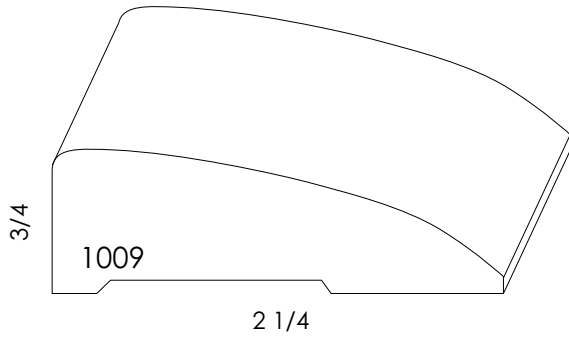

Casing

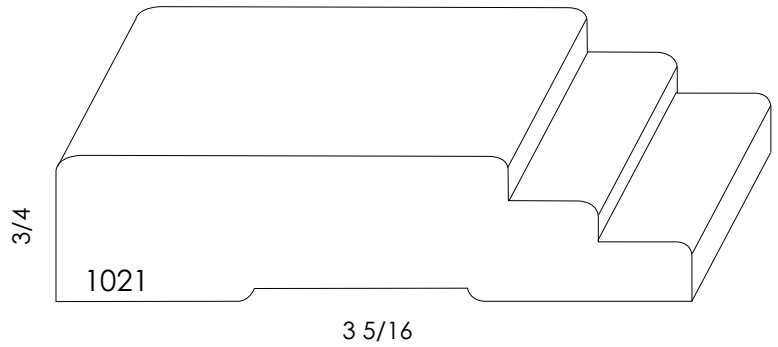
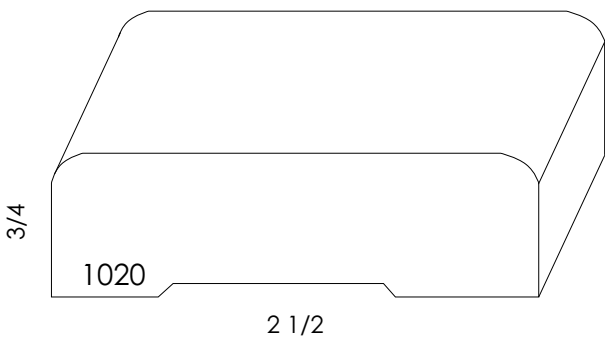
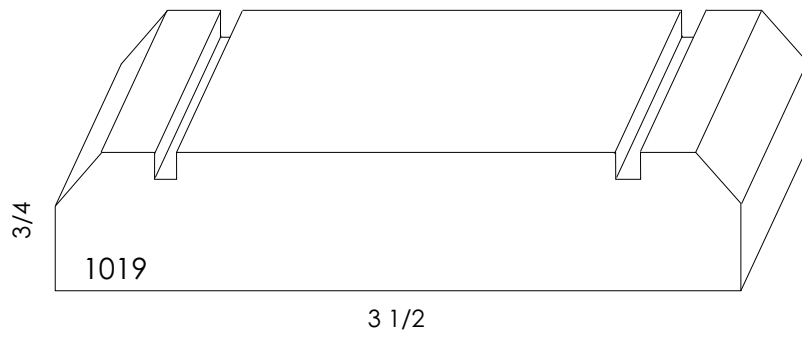
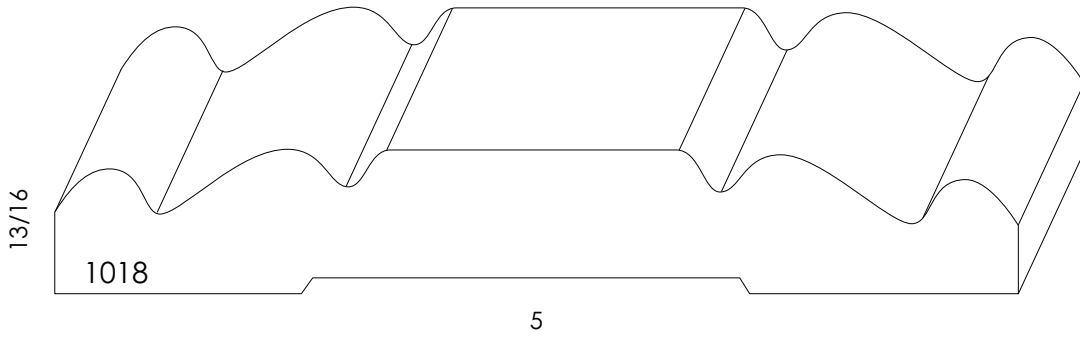
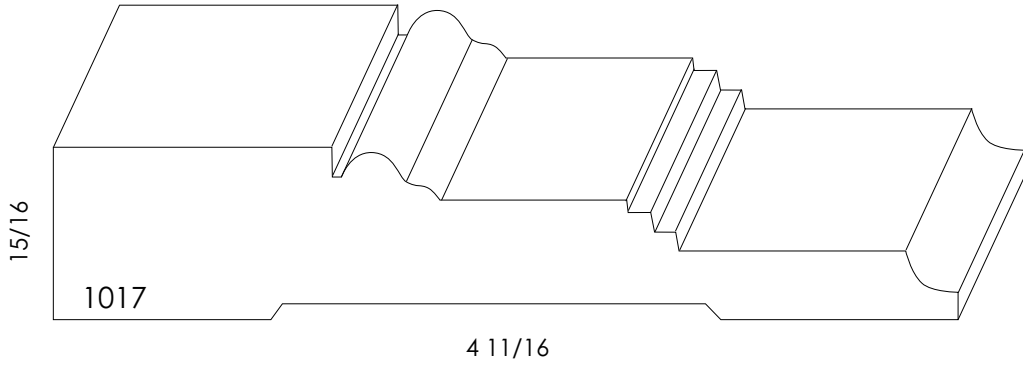
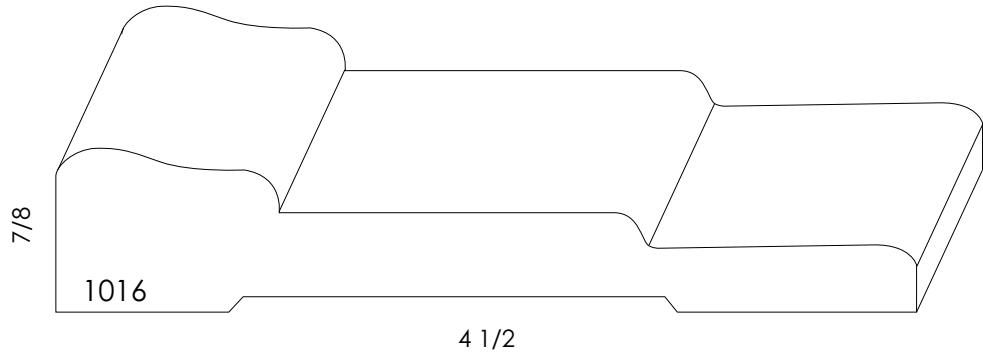

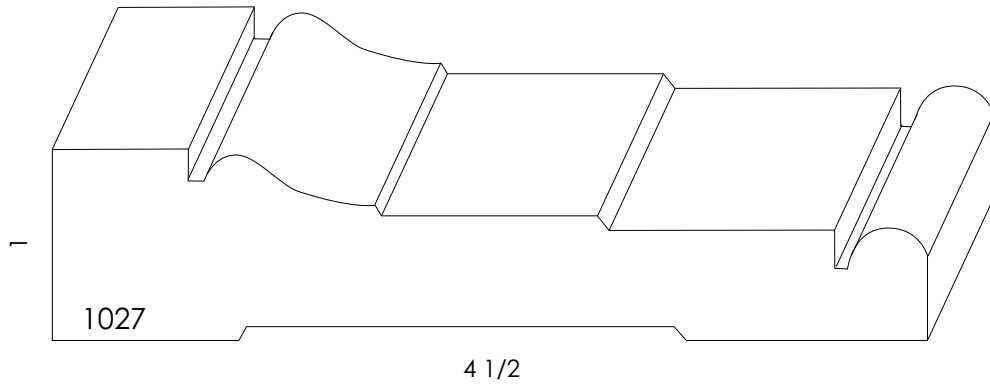
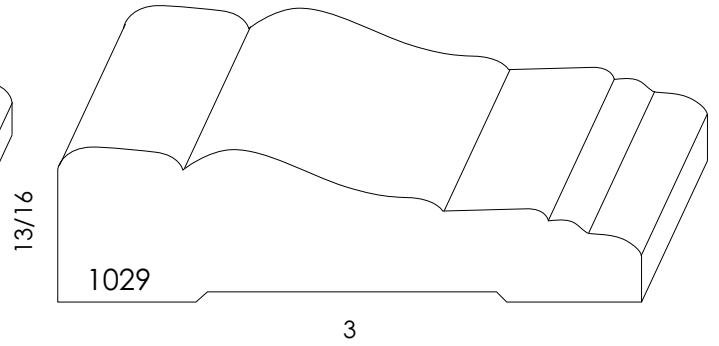
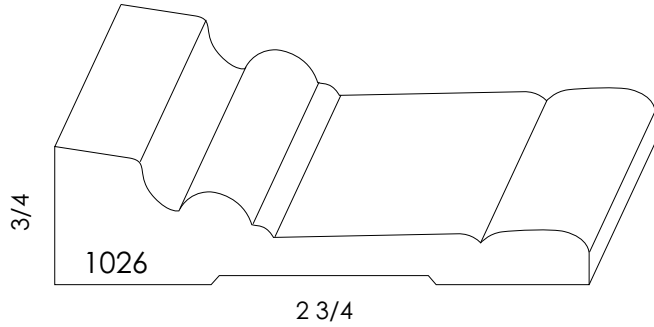
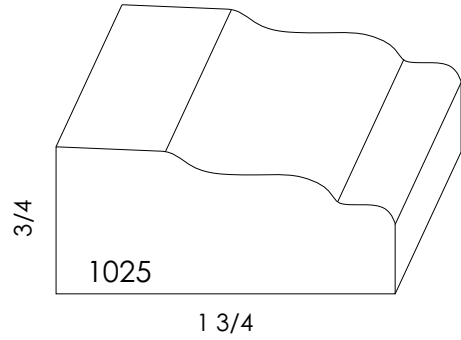
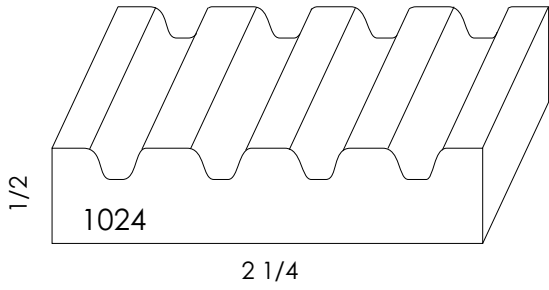
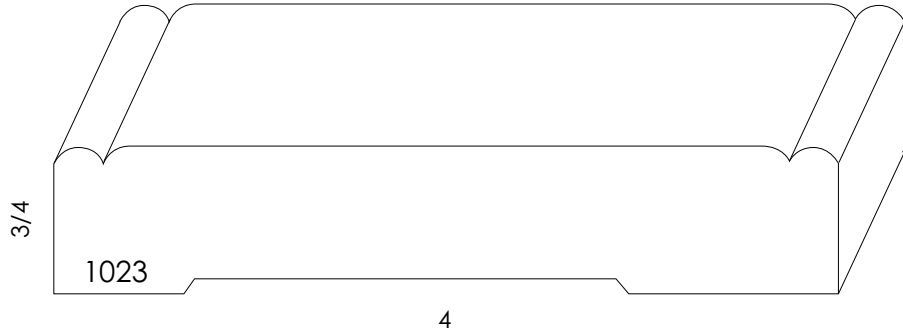
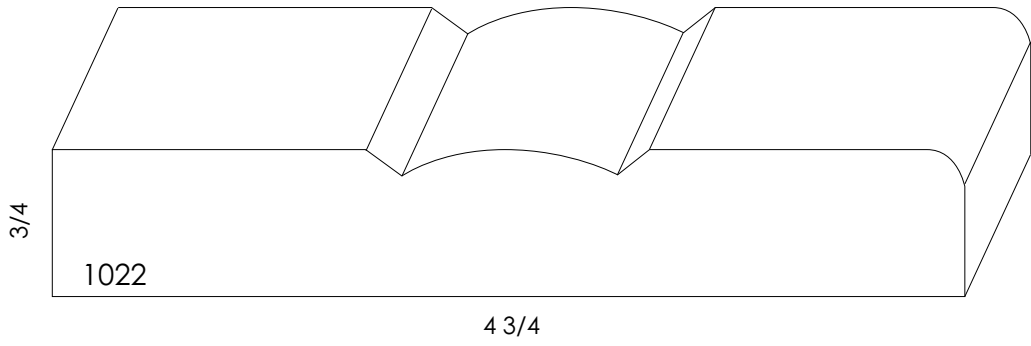

Casing

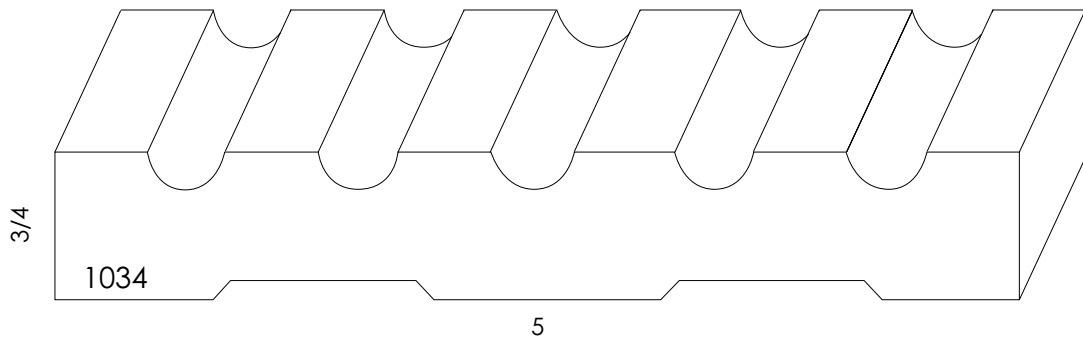
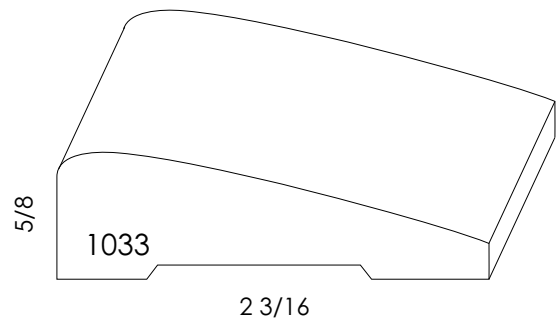
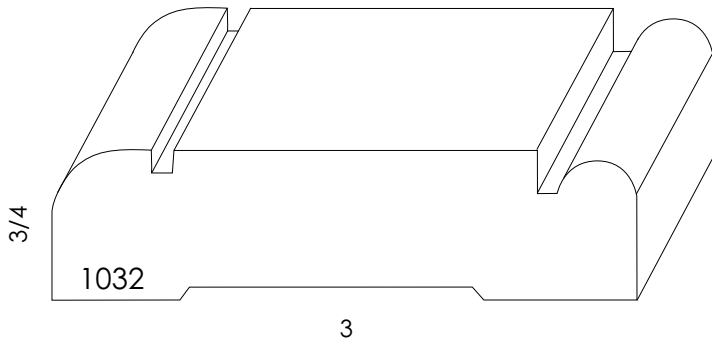
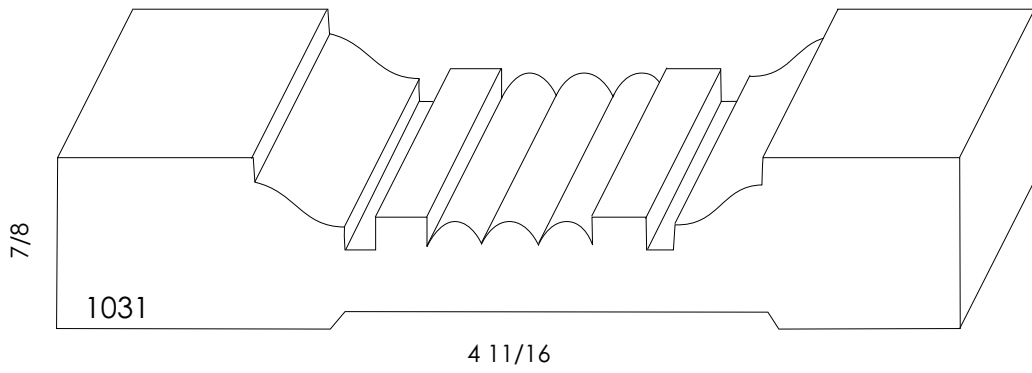
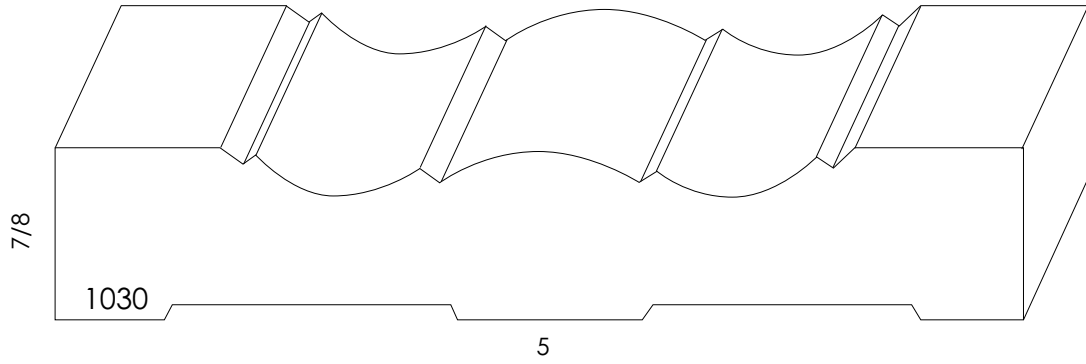
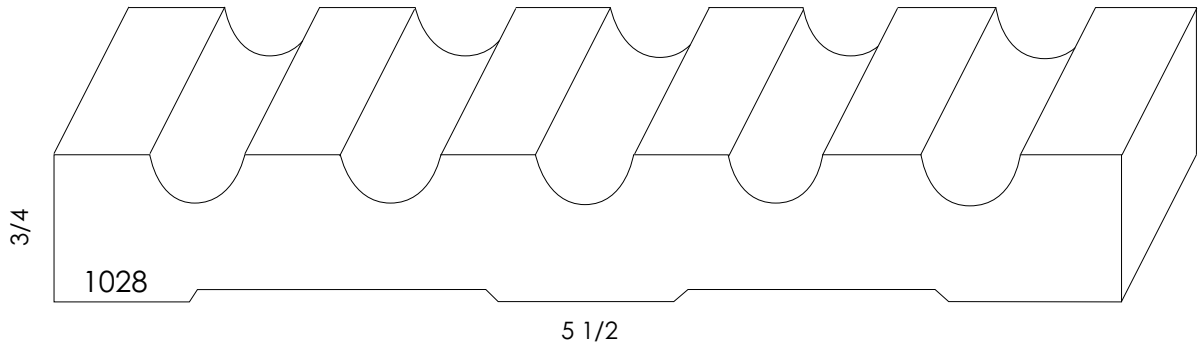

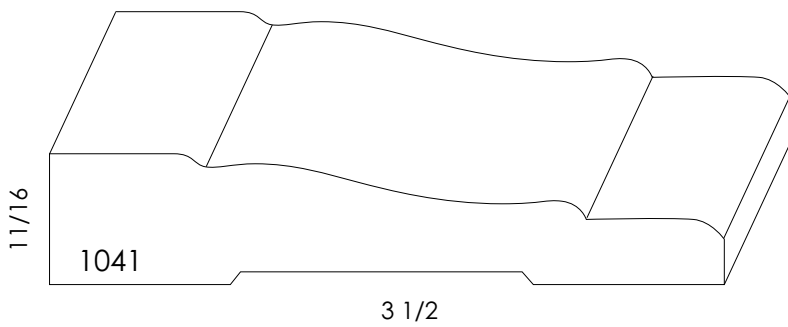
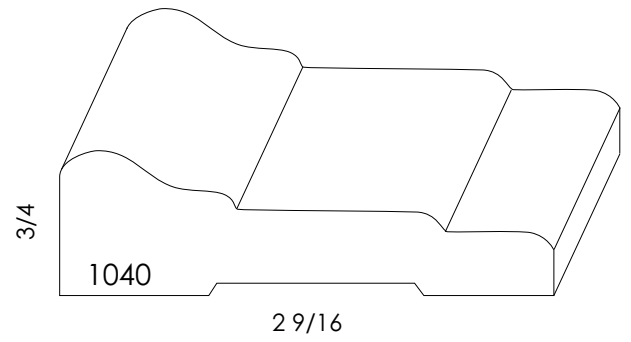
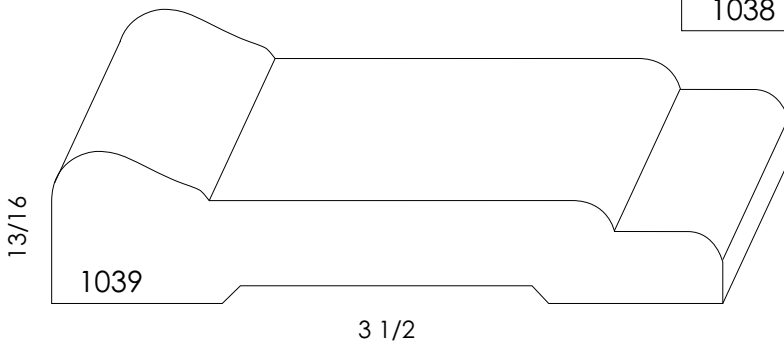
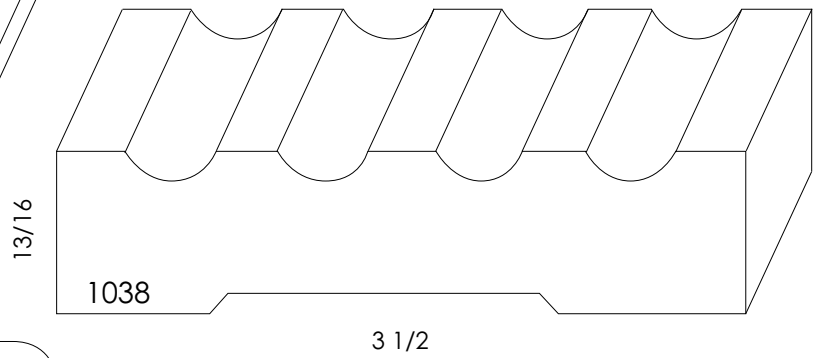
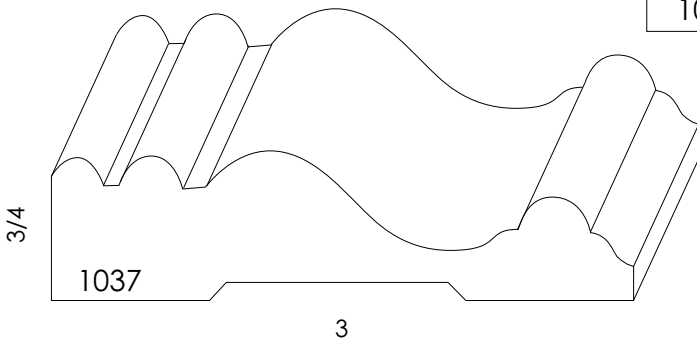
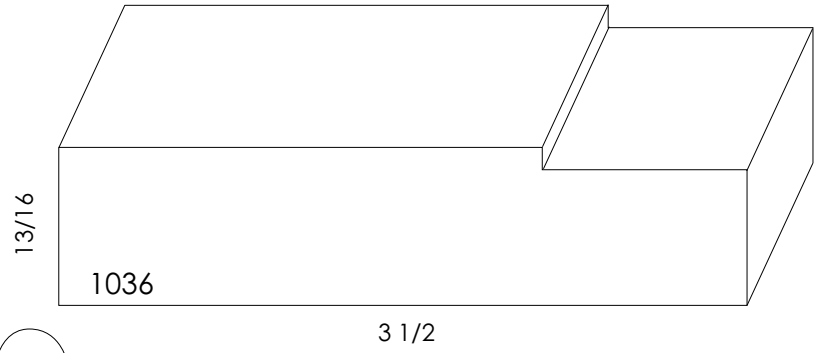
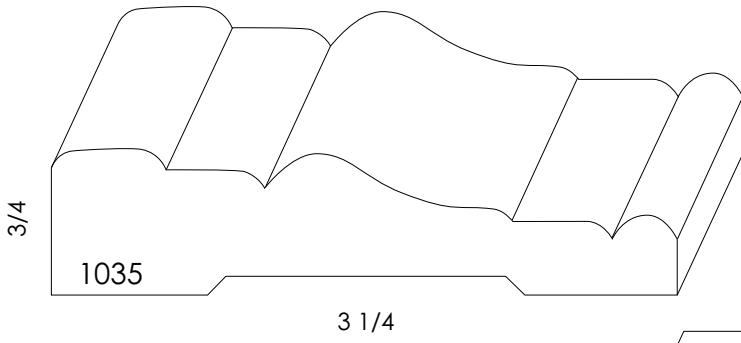

Casing

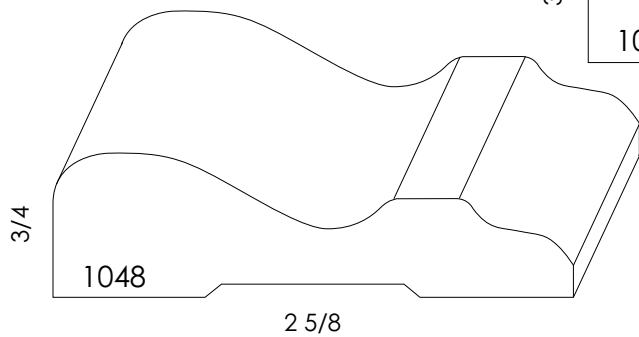
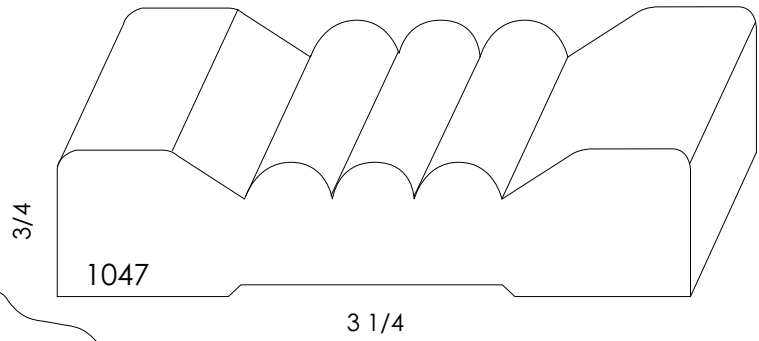
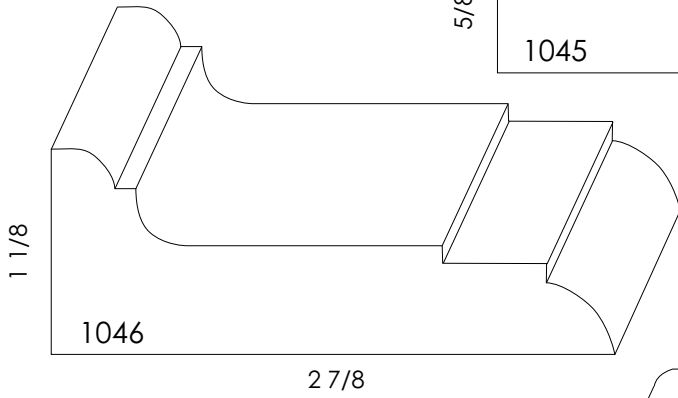
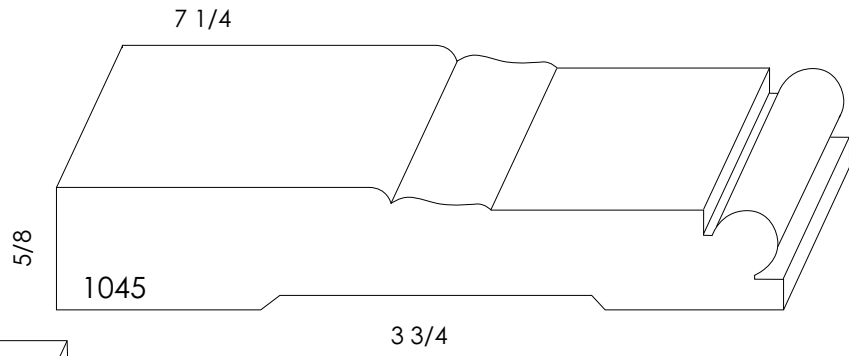
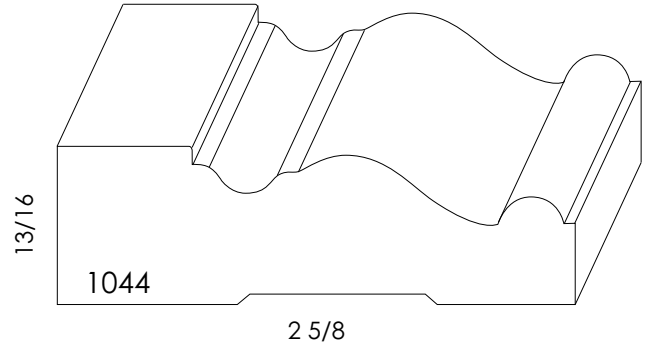
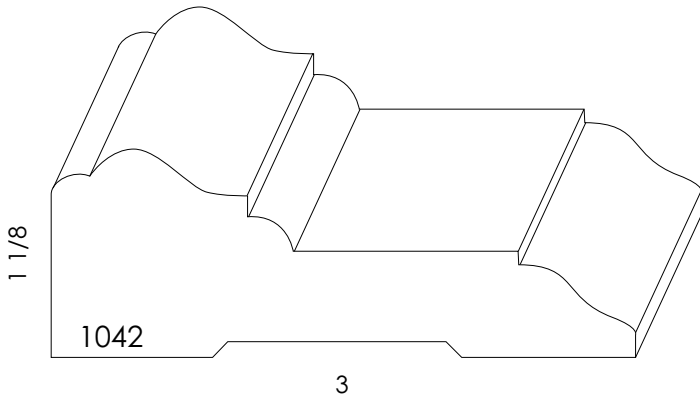

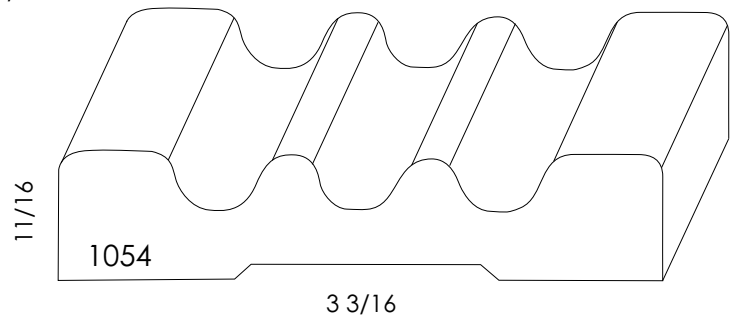
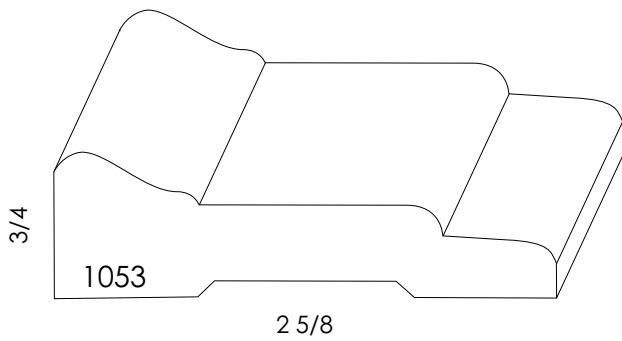
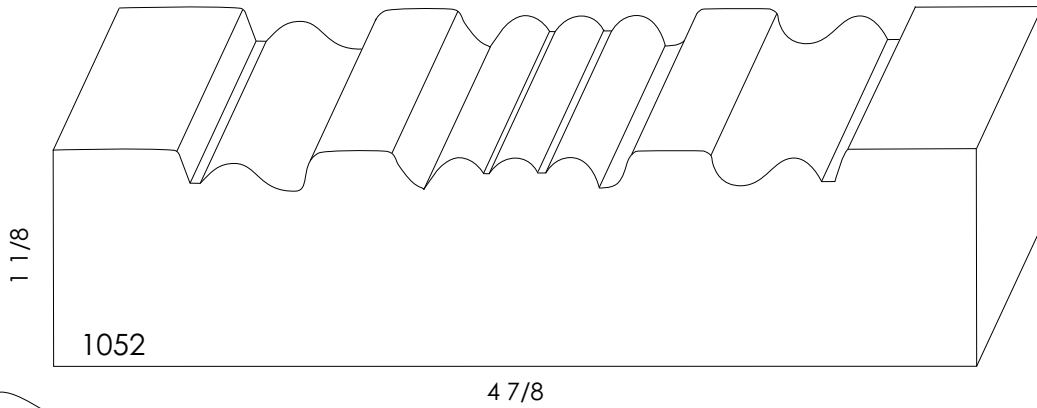
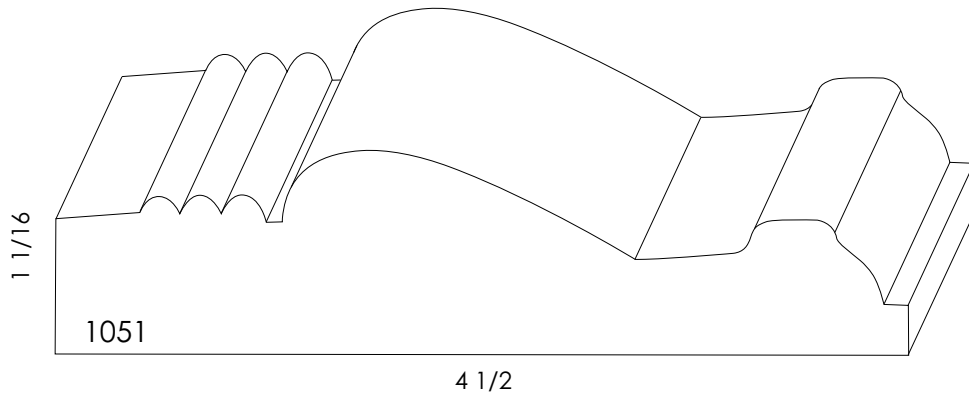
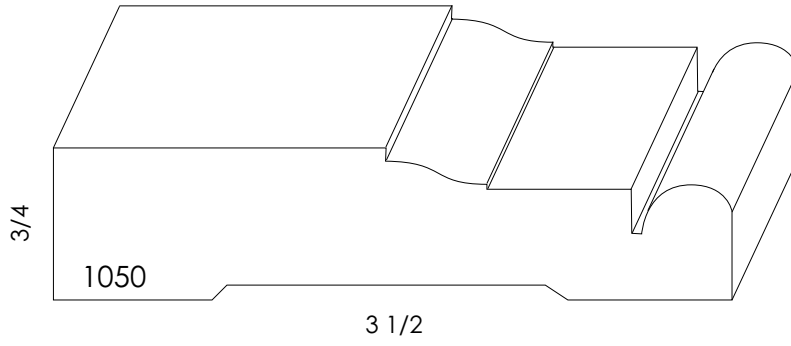
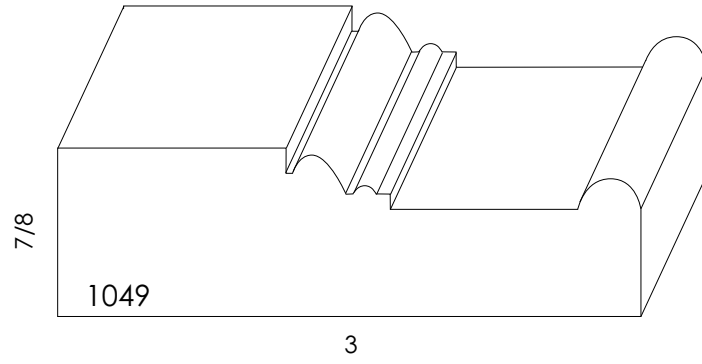

Casing

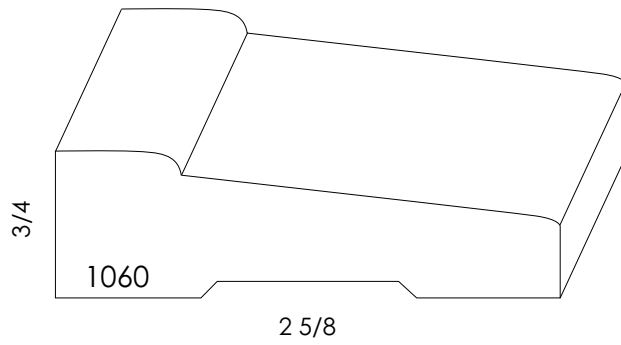
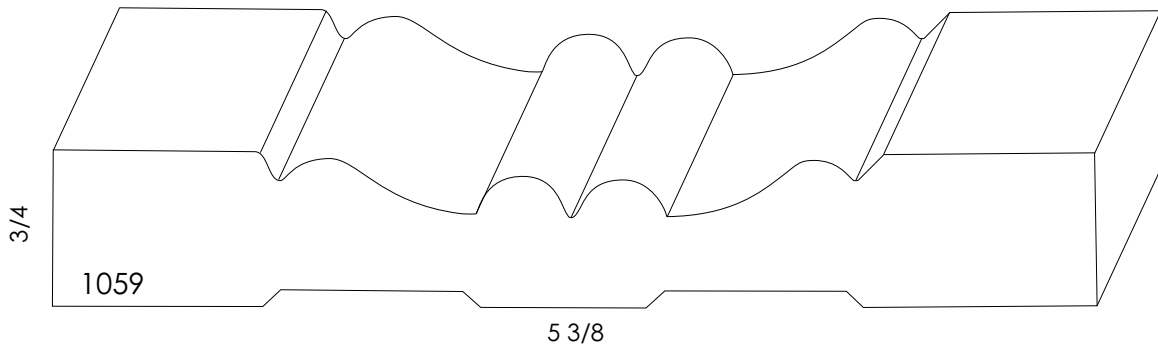
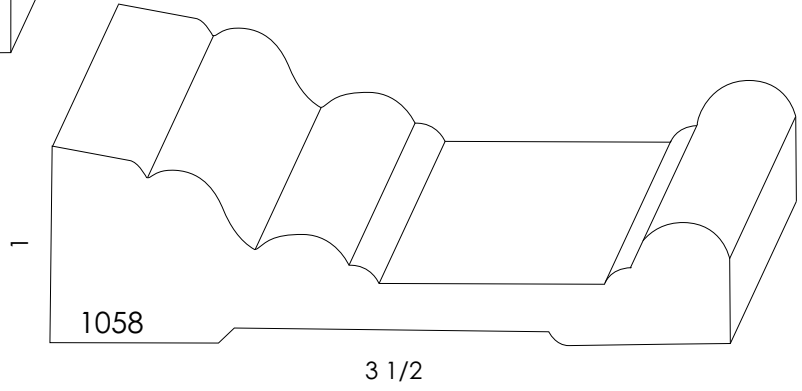
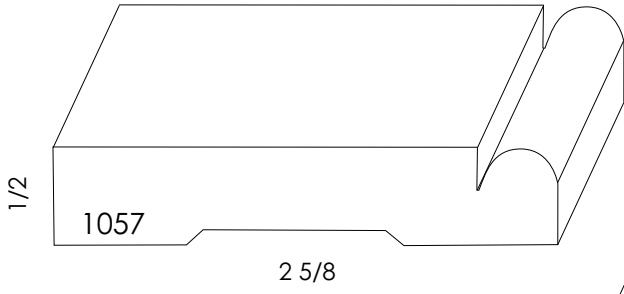
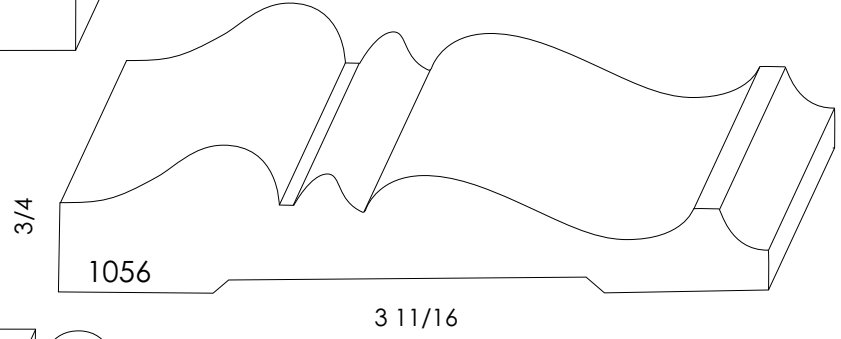
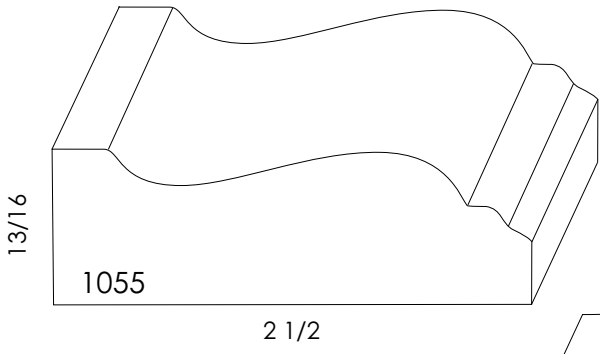

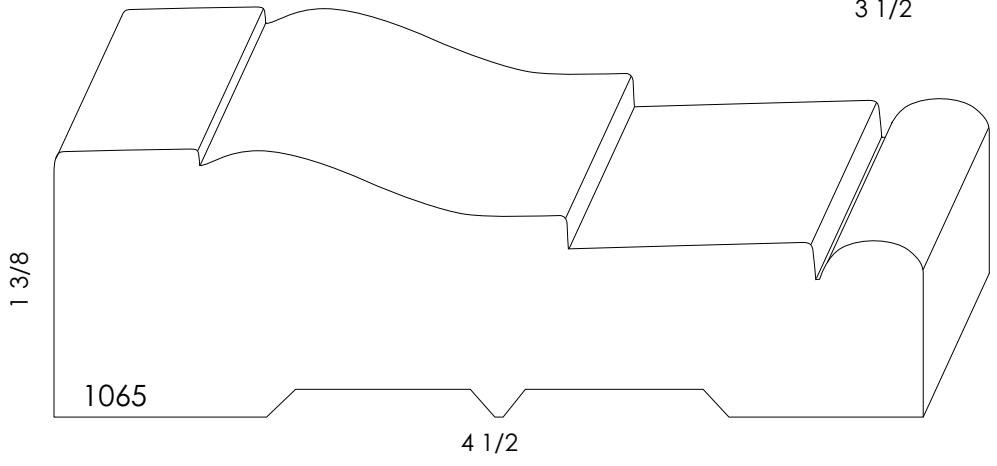
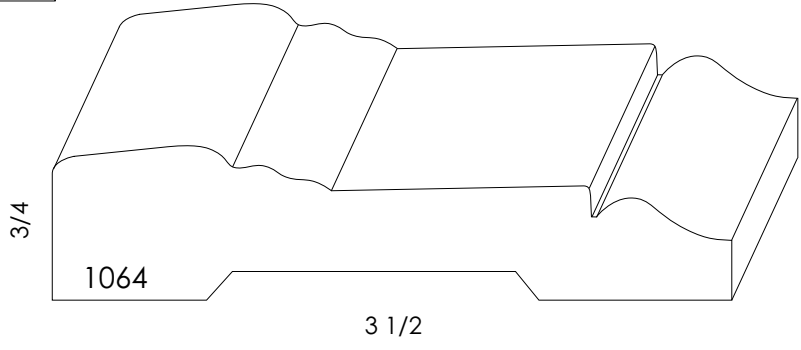
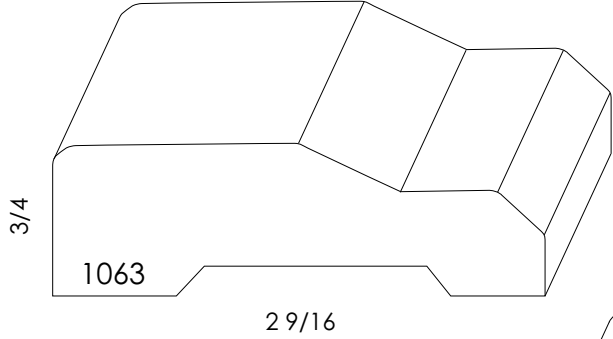
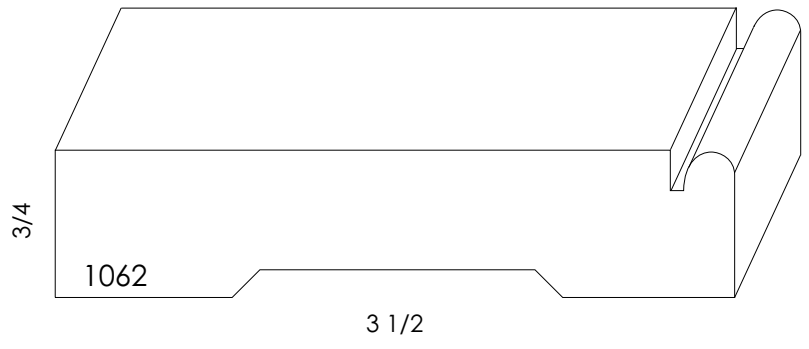
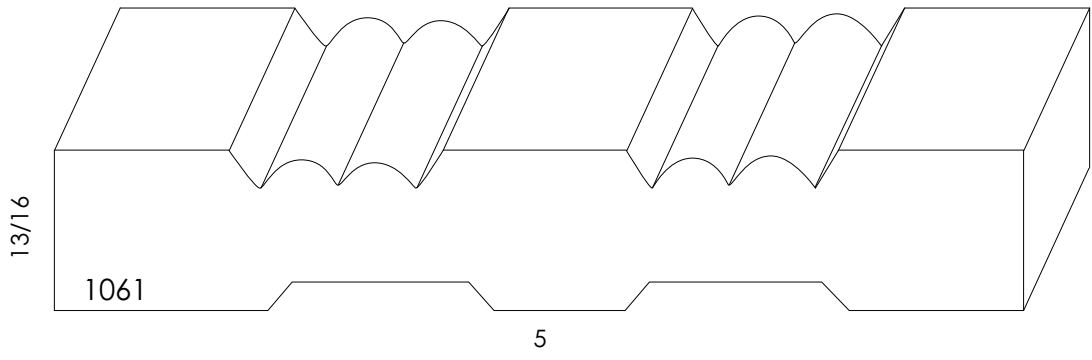

Casing

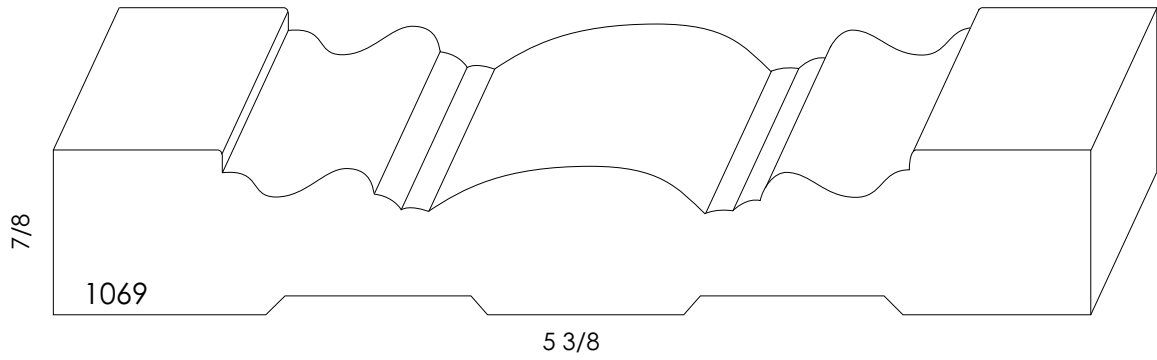
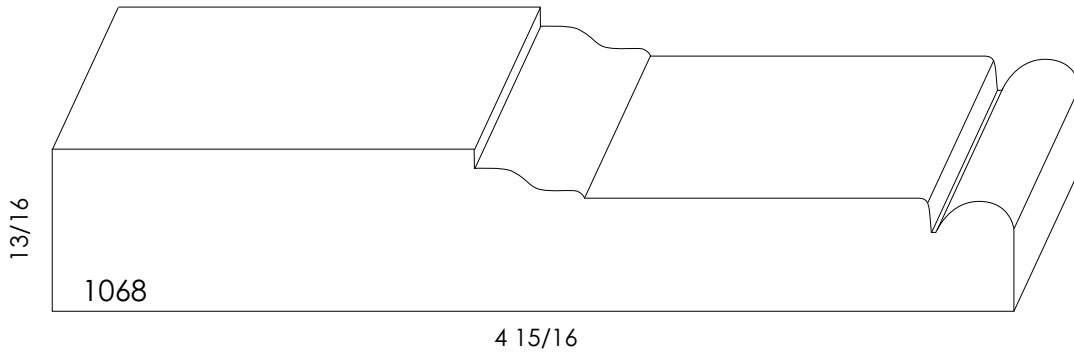
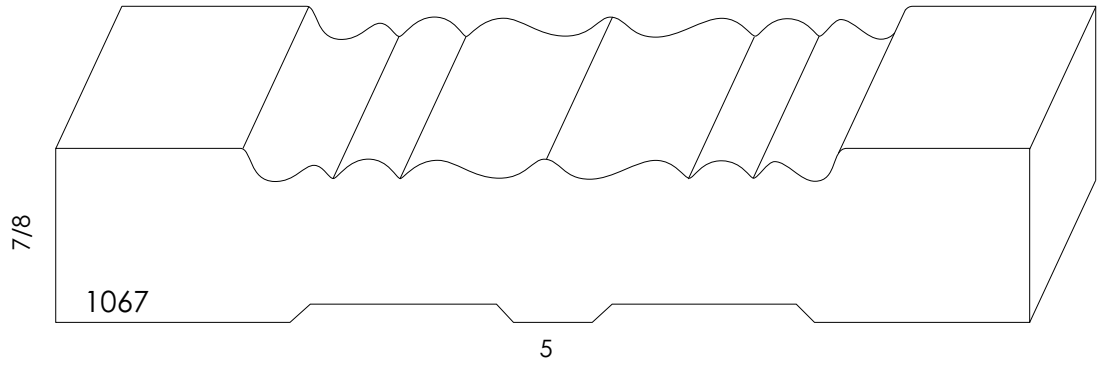
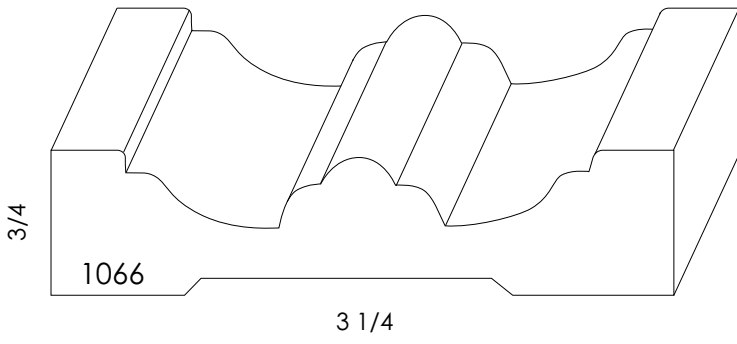

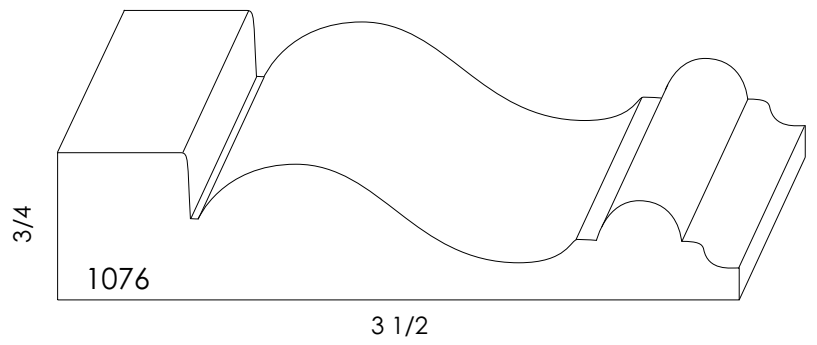
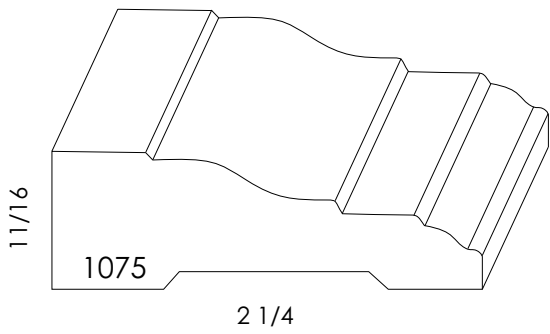
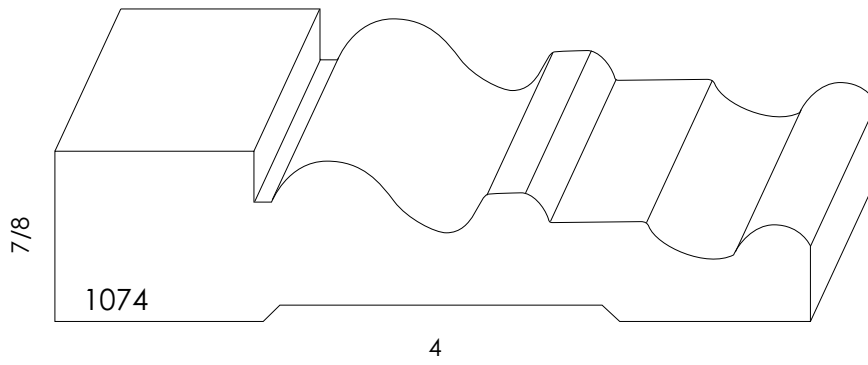
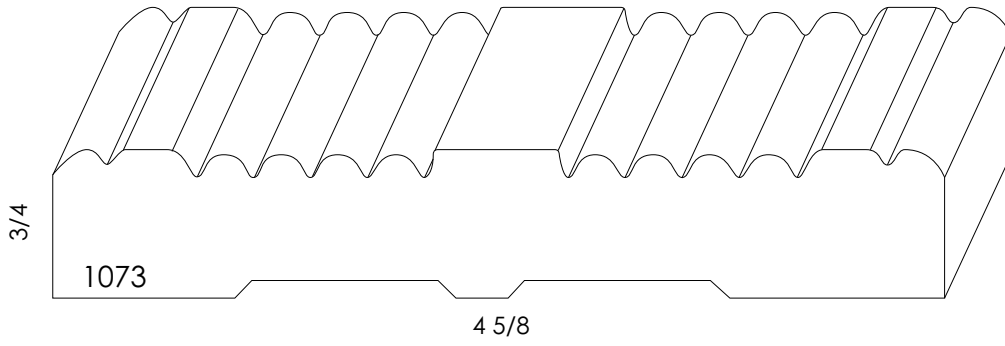
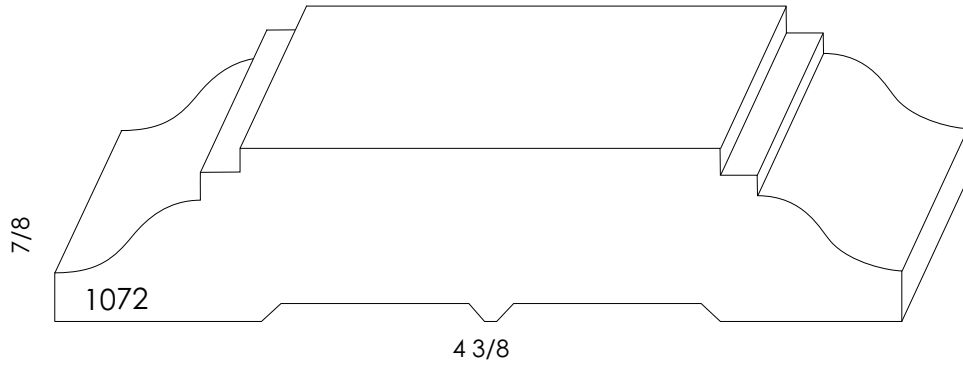
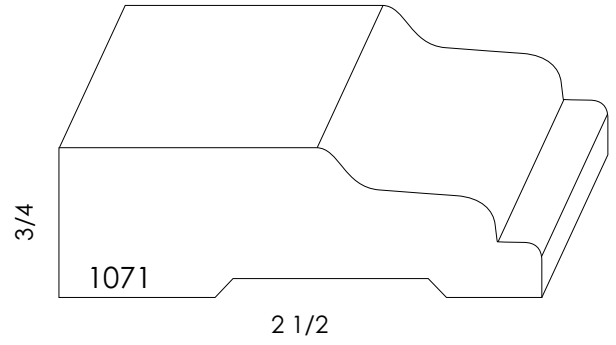
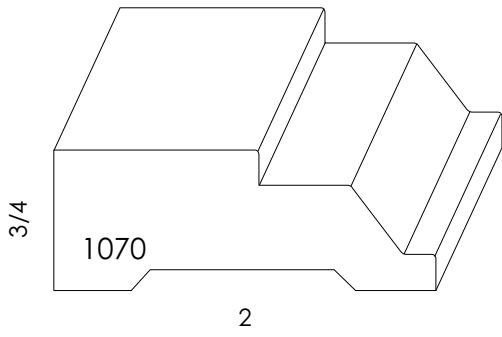

Casing

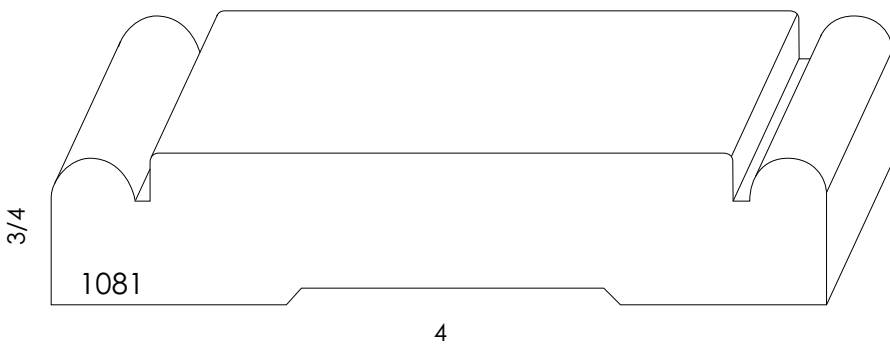
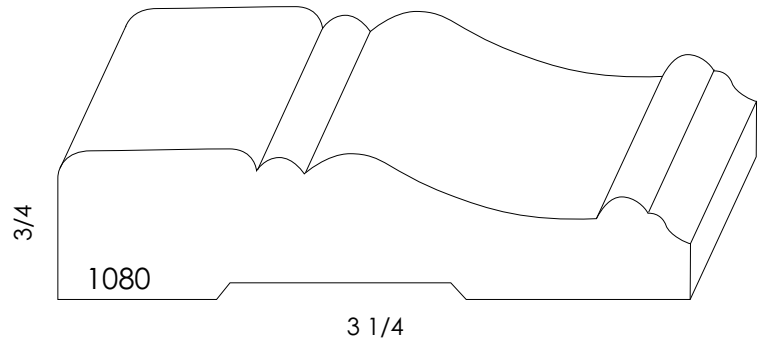
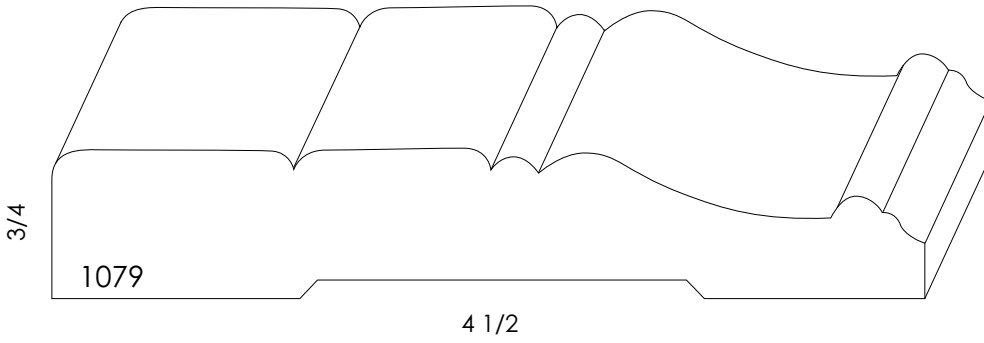
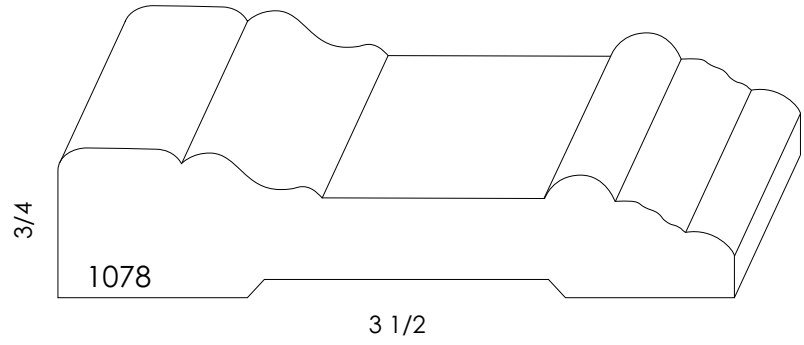
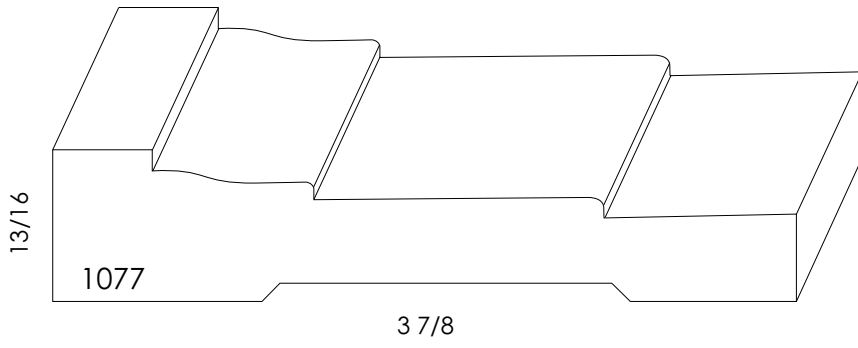

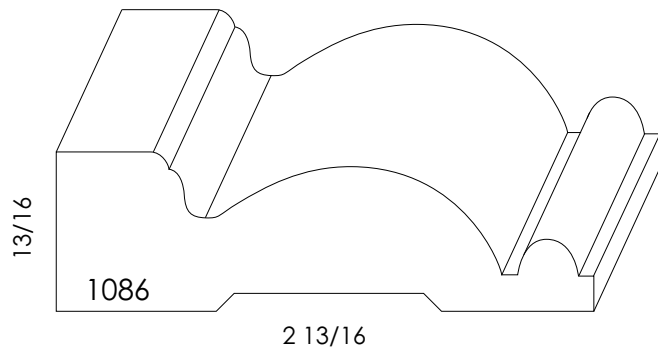
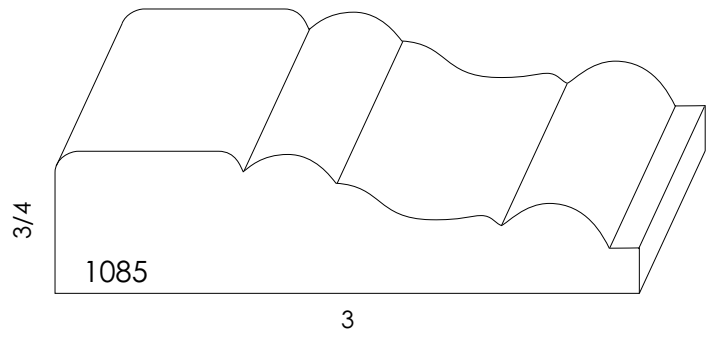
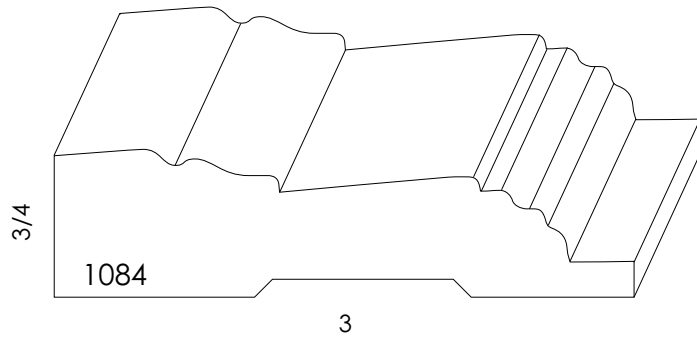
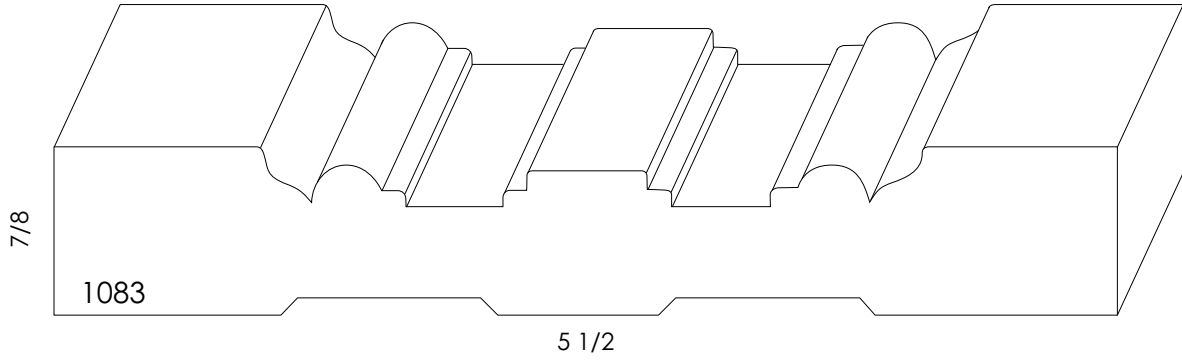
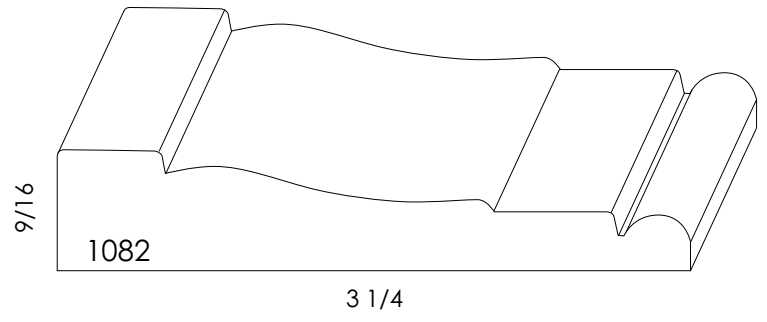

Casing

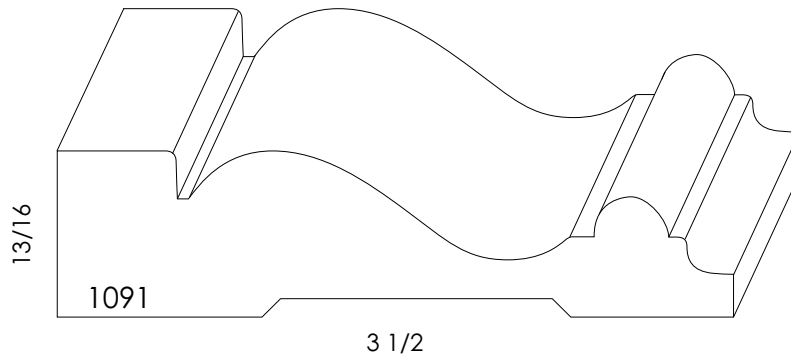
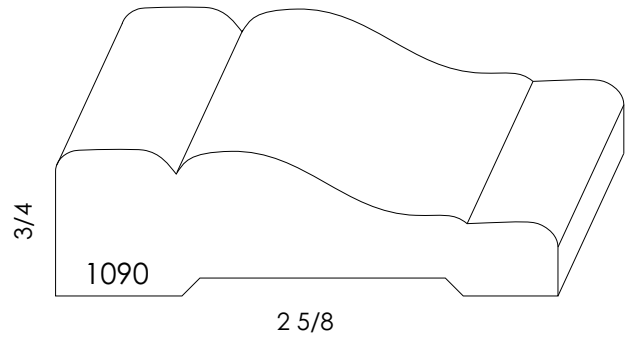
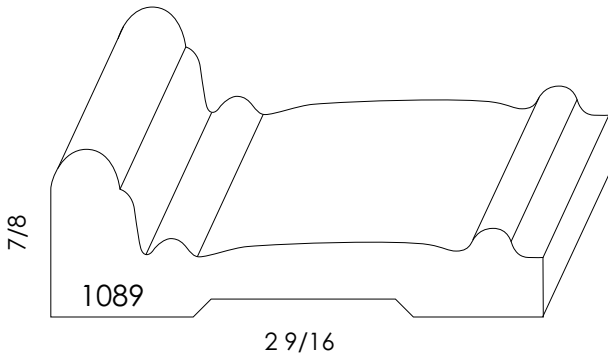
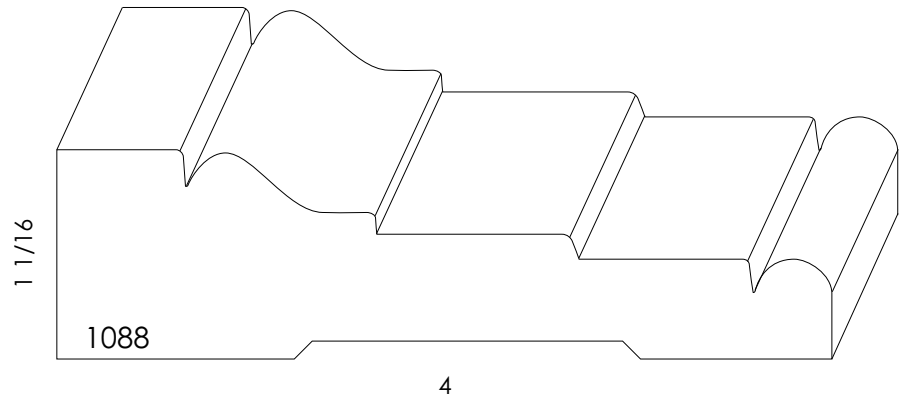
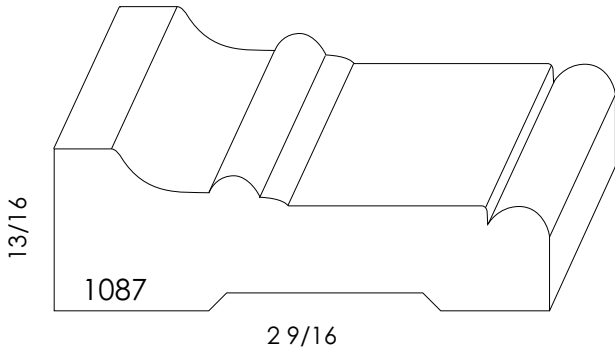

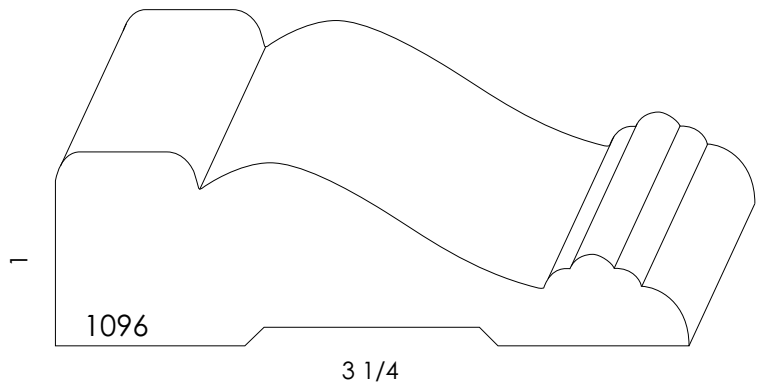
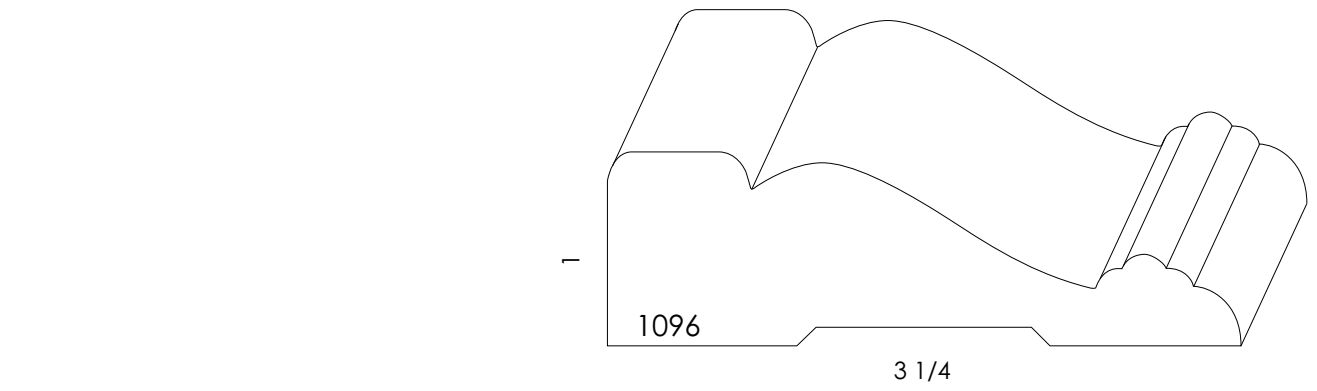
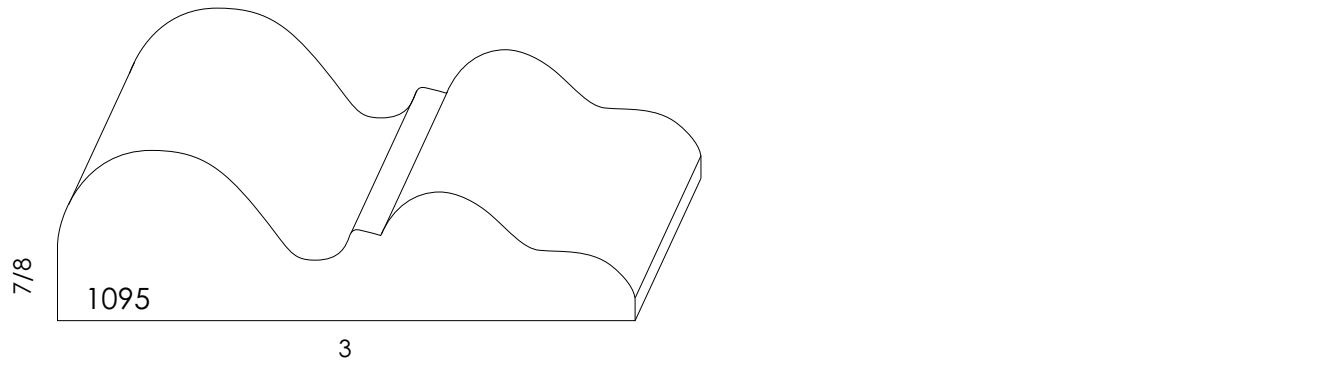
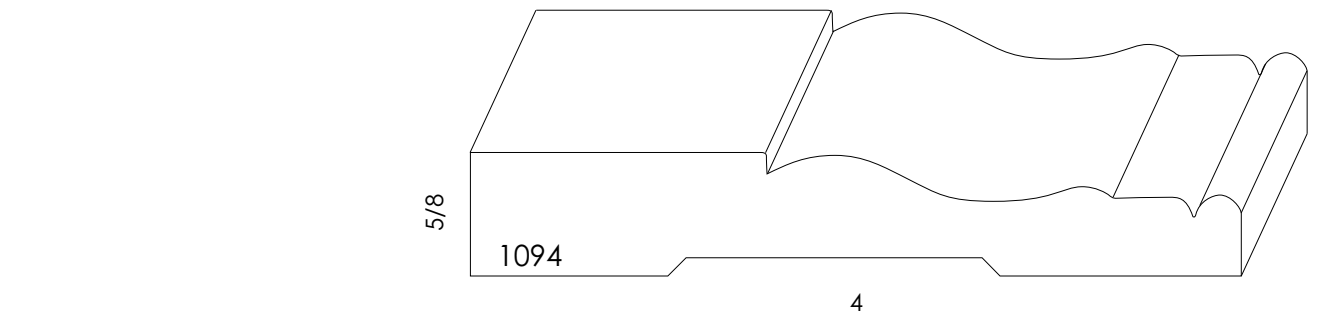
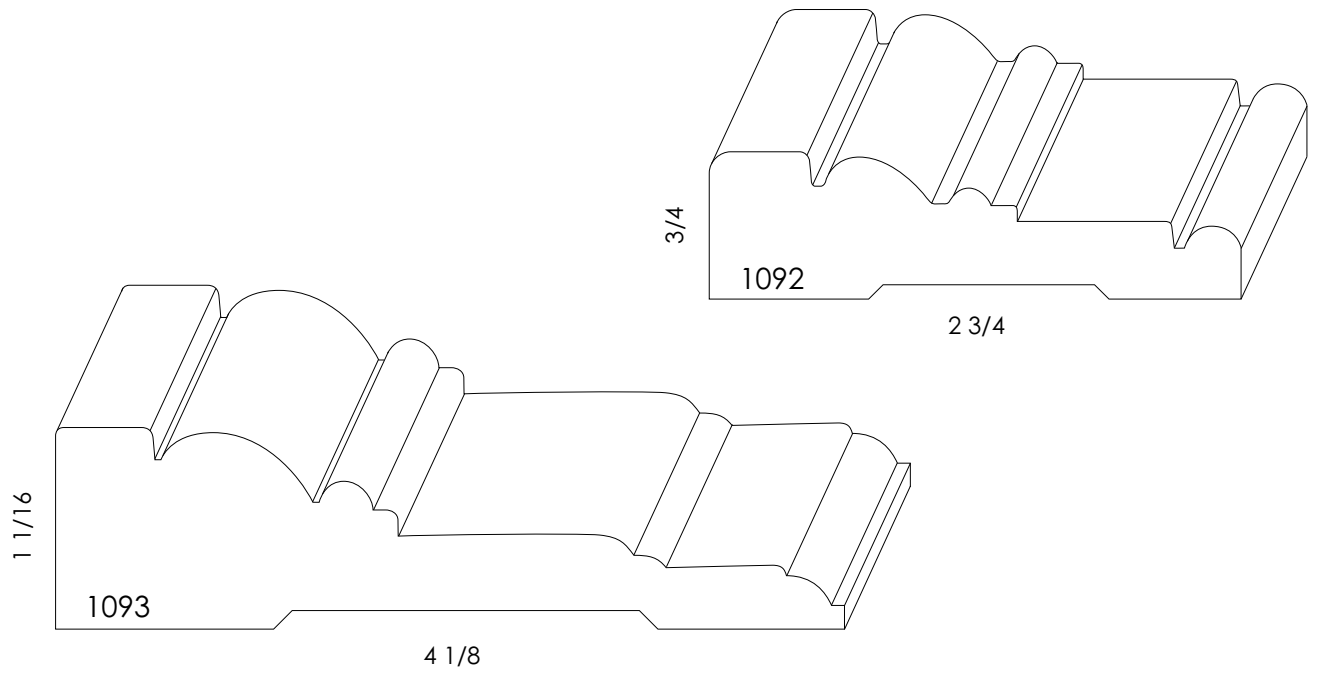

Casing

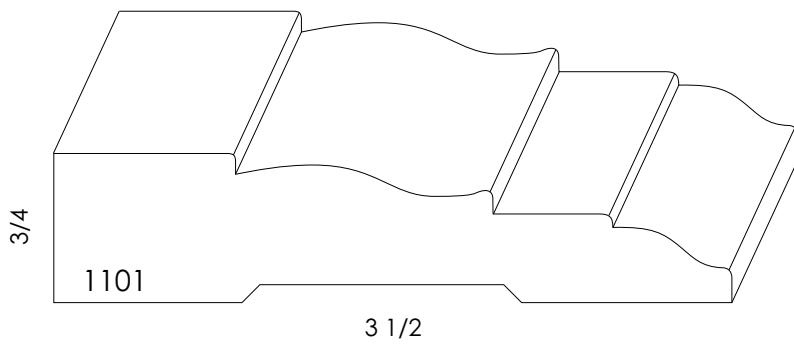
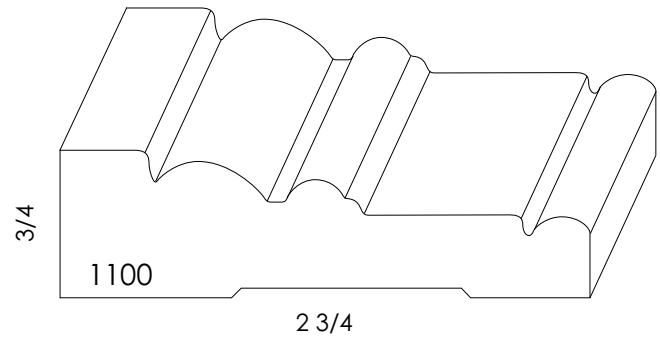
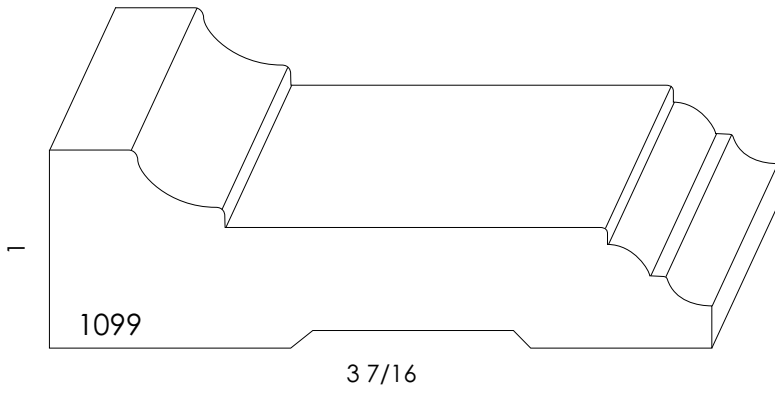
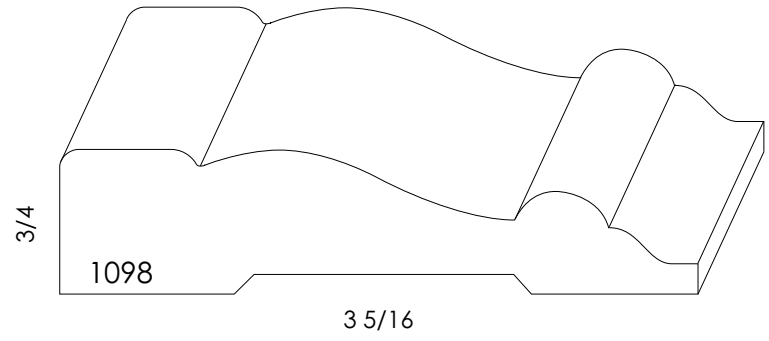
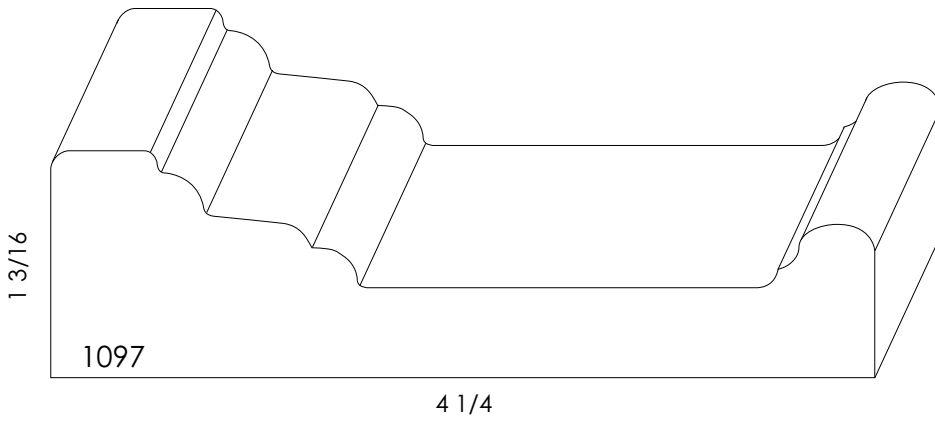

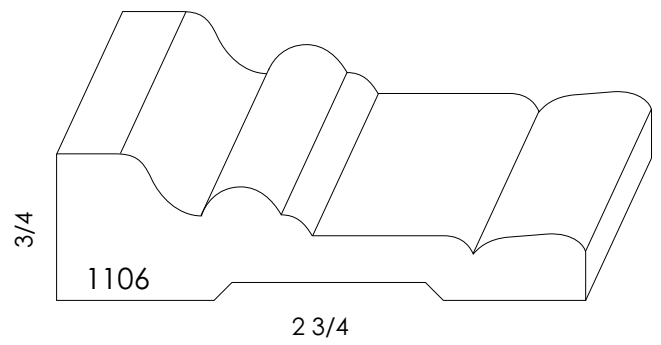
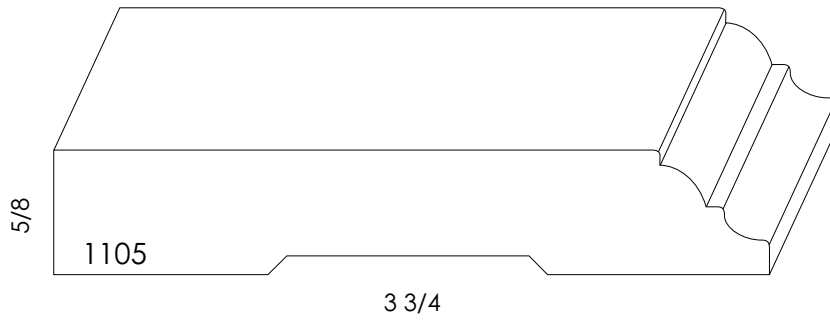
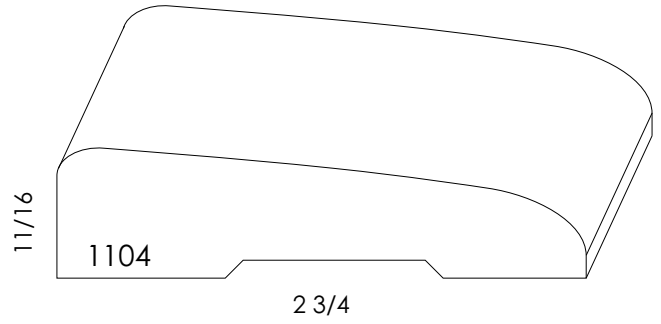
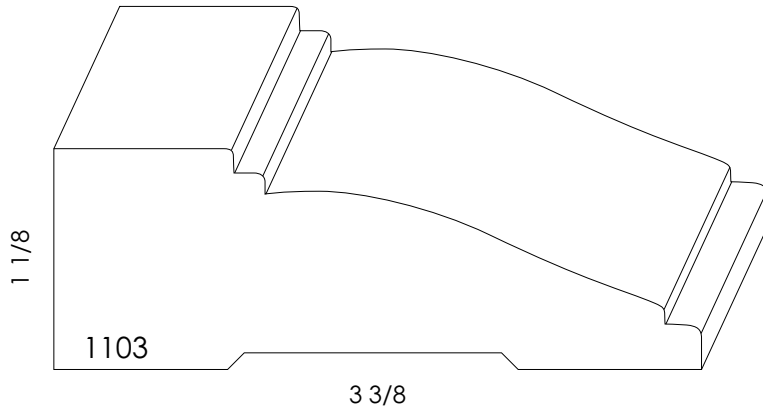
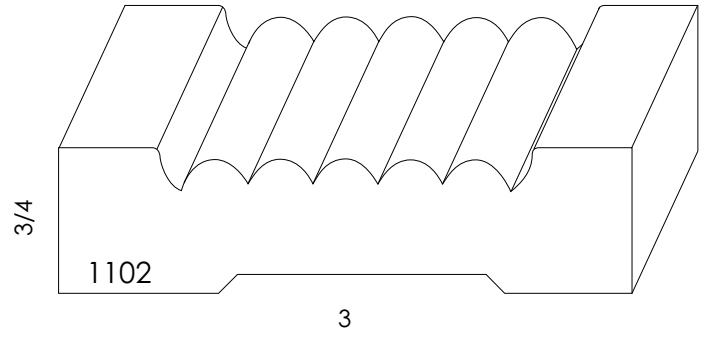

Casing

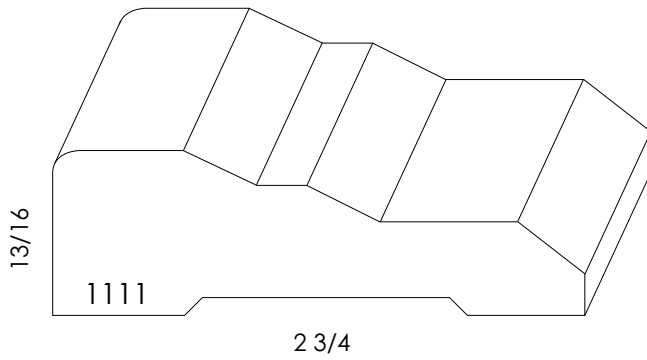
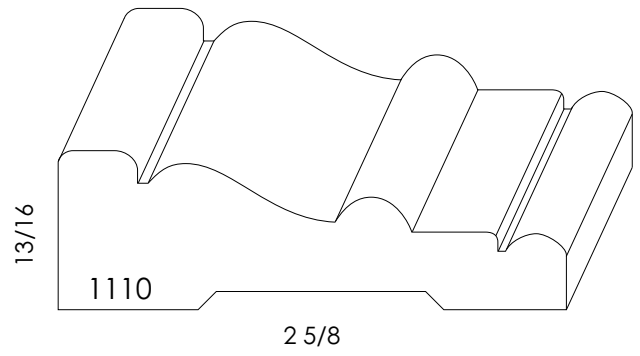
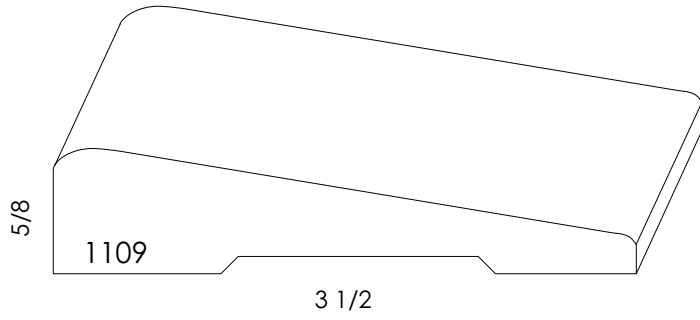
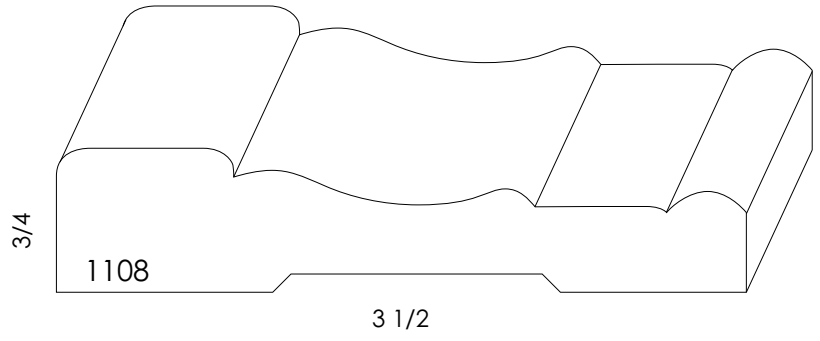
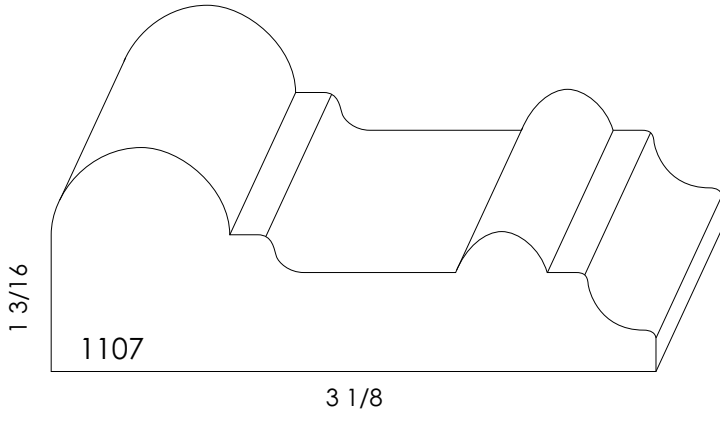

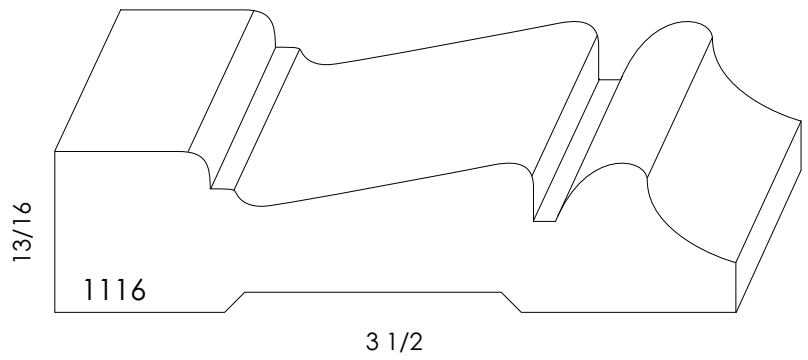
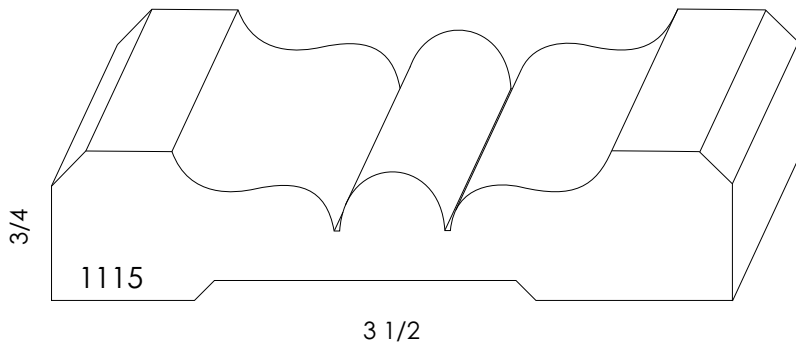
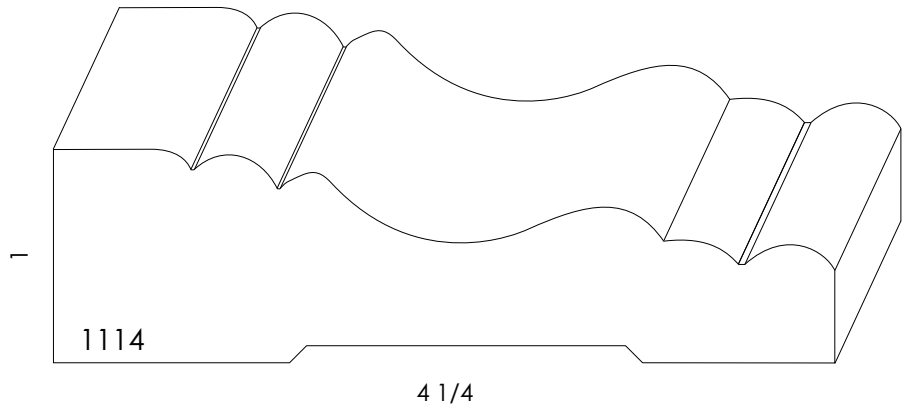
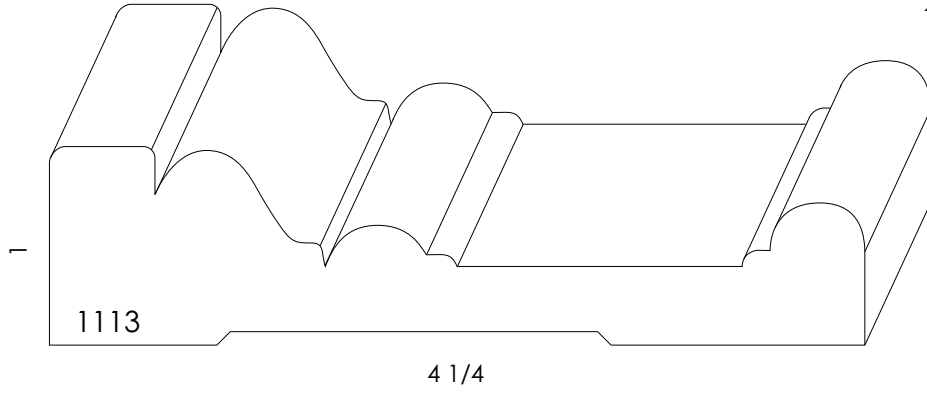
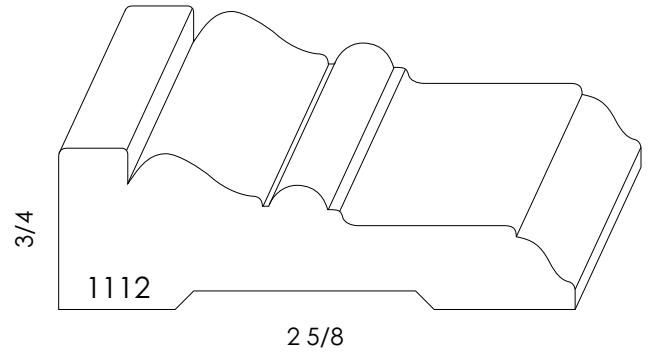

Casing

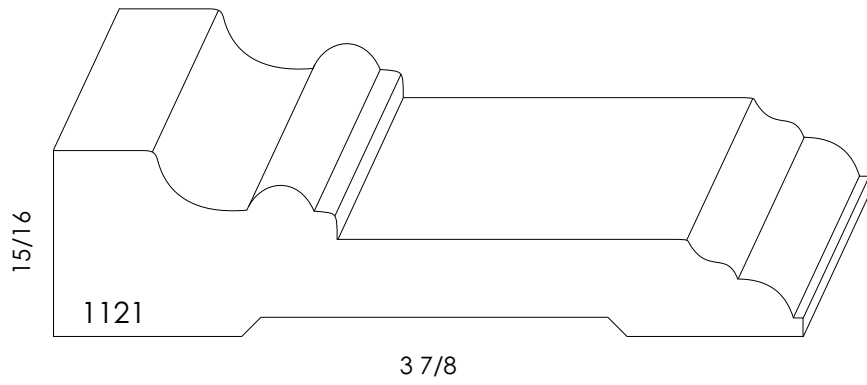
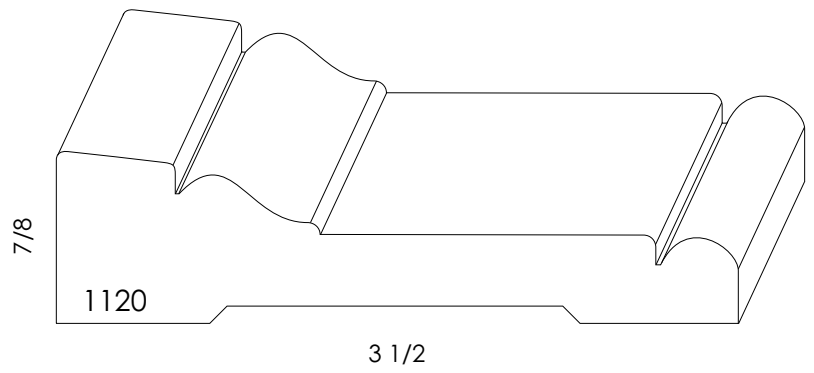
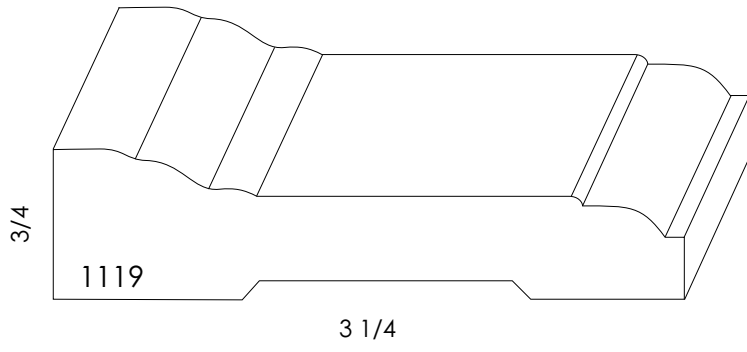
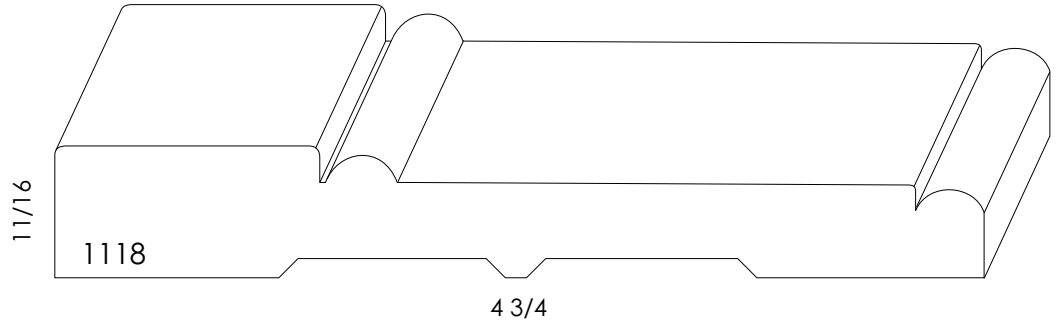
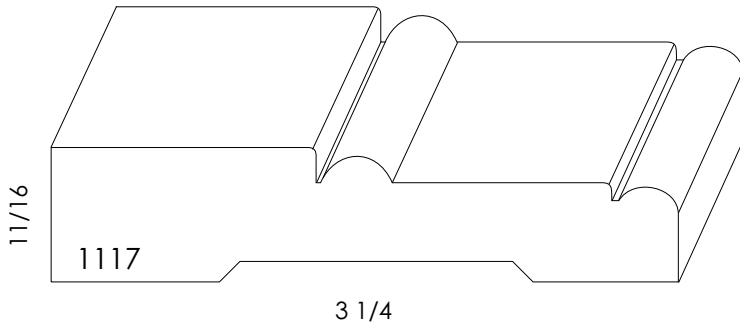

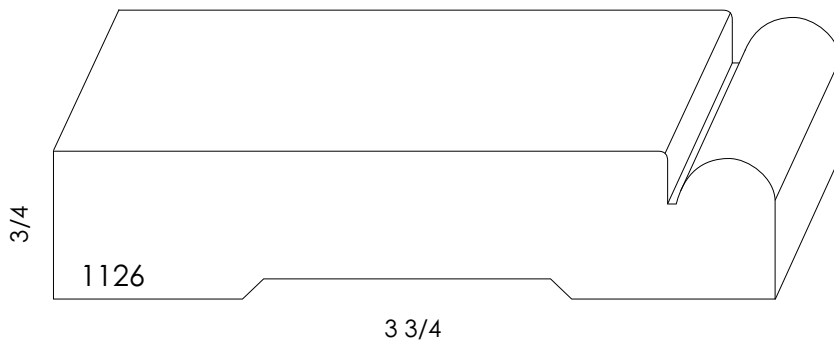
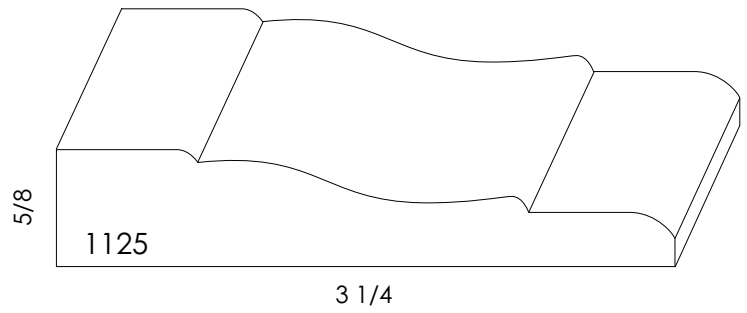
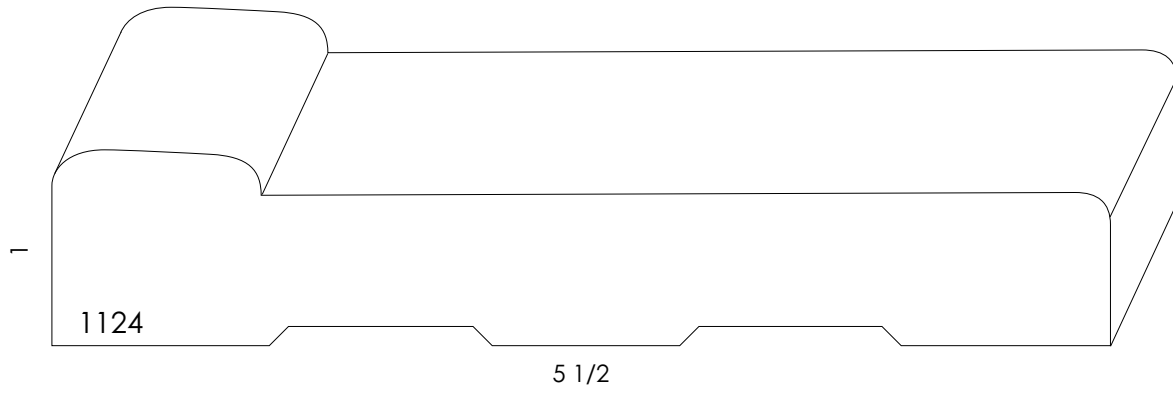
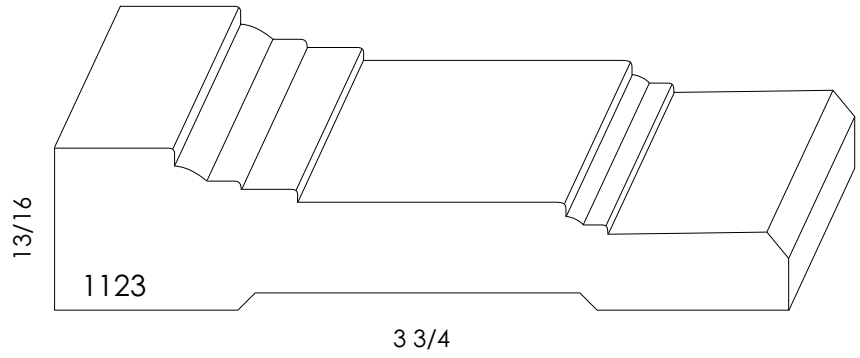
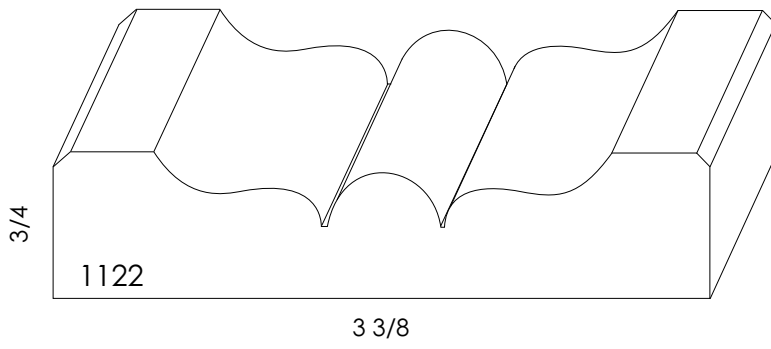

Casing

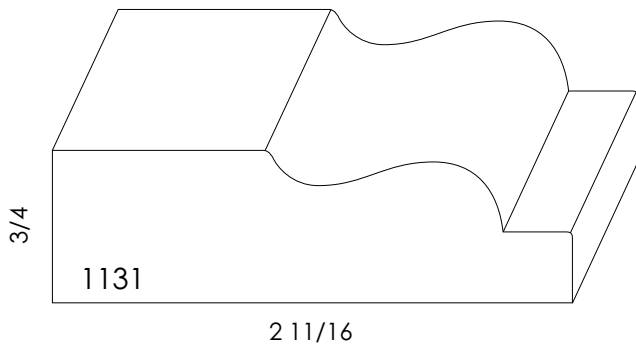
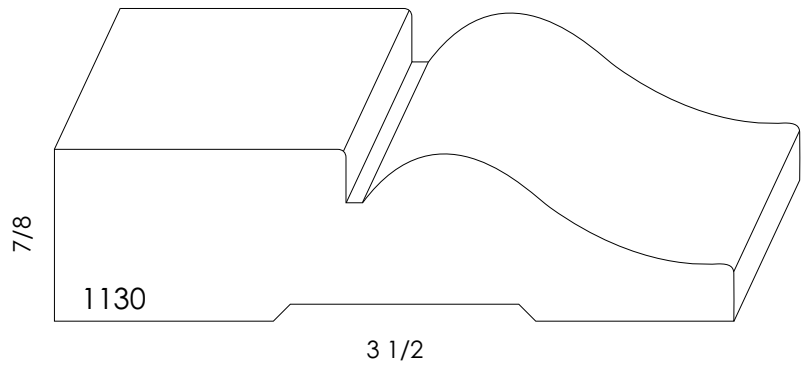
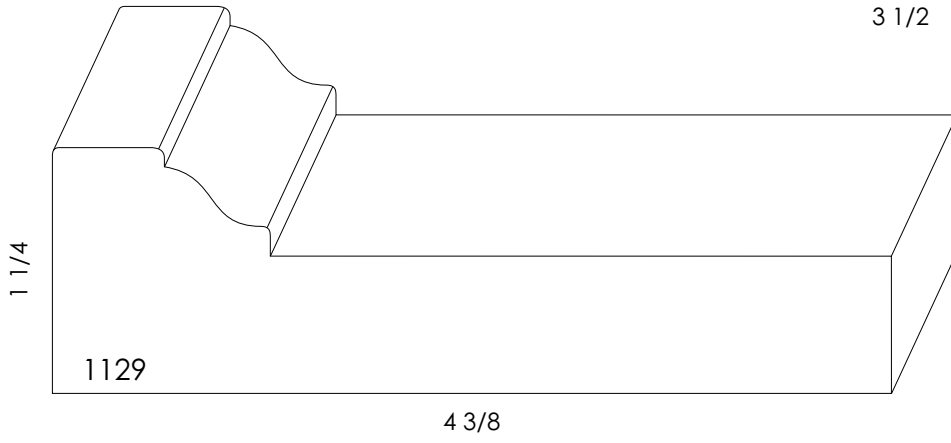
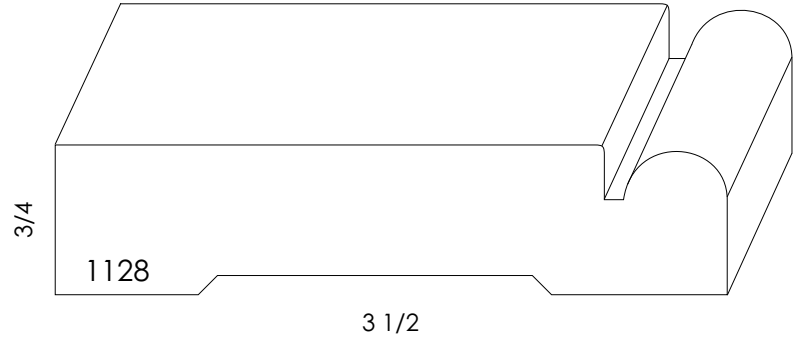
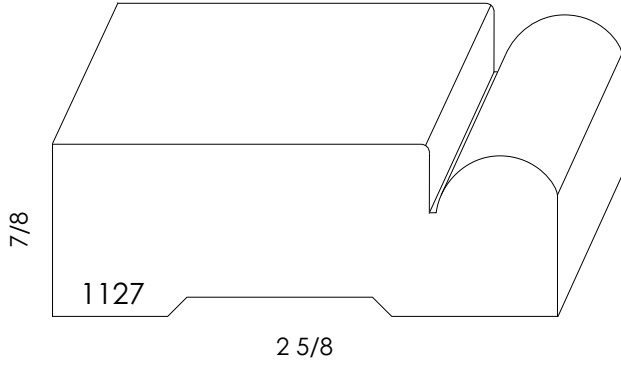

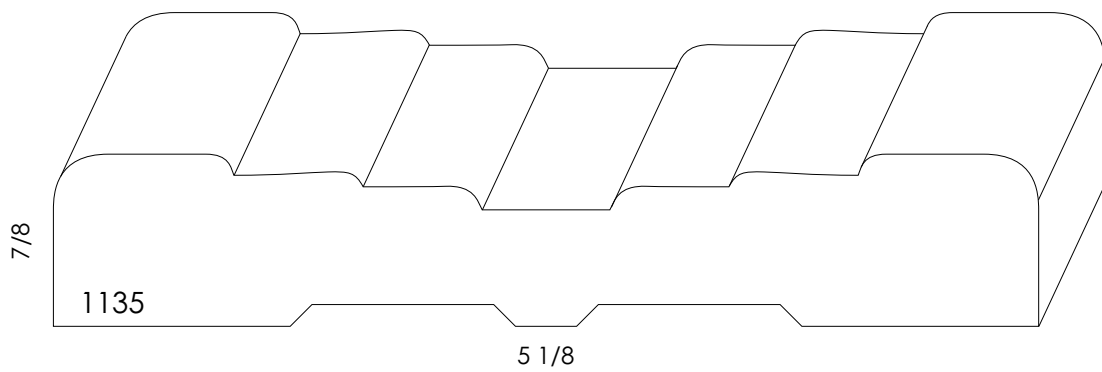
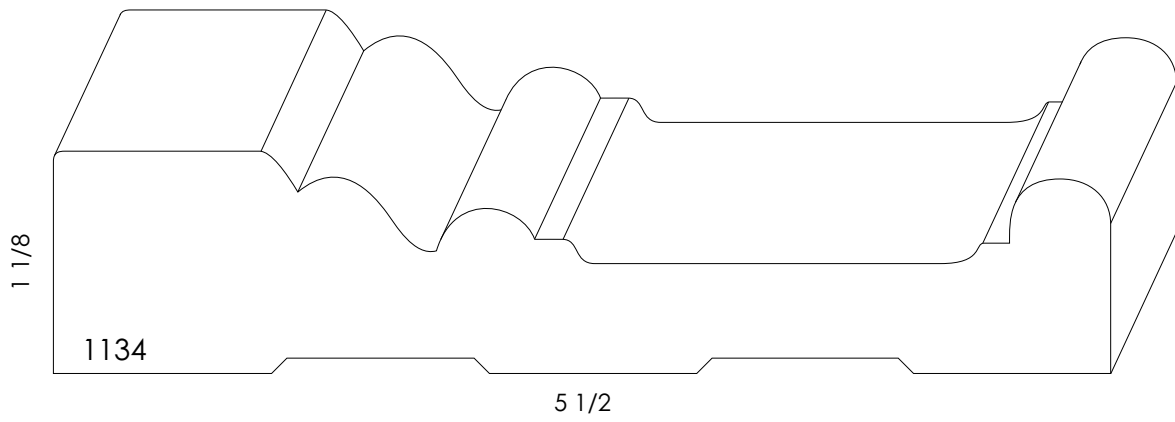
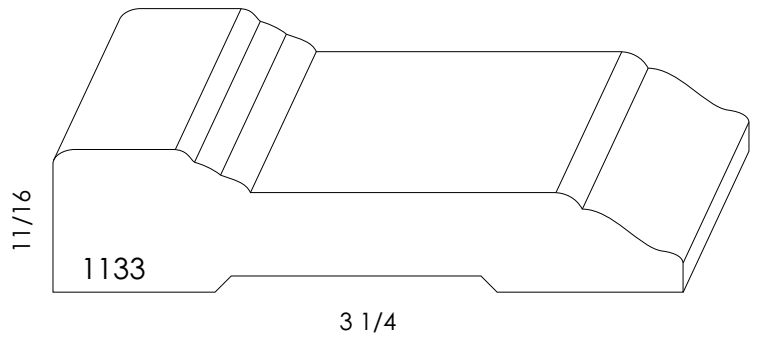
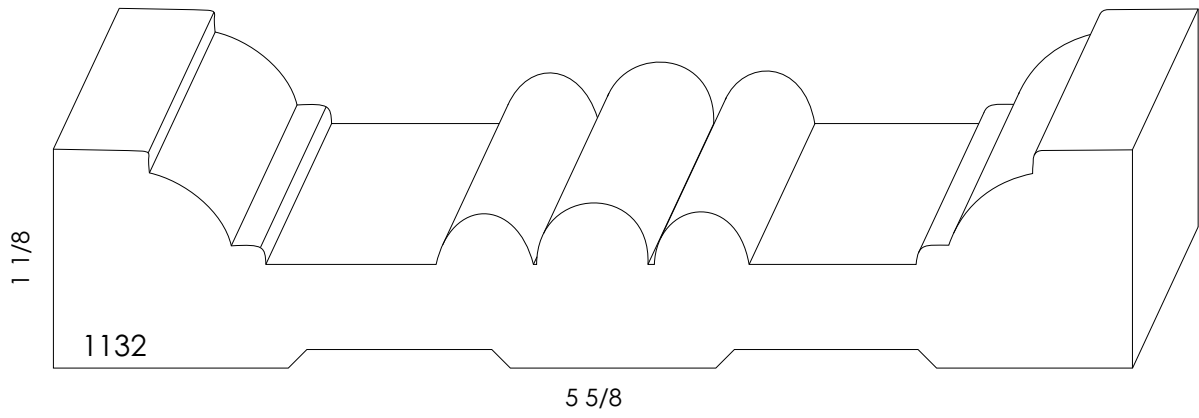

Casing

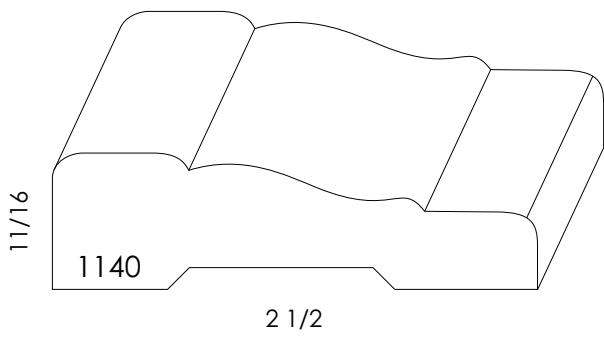
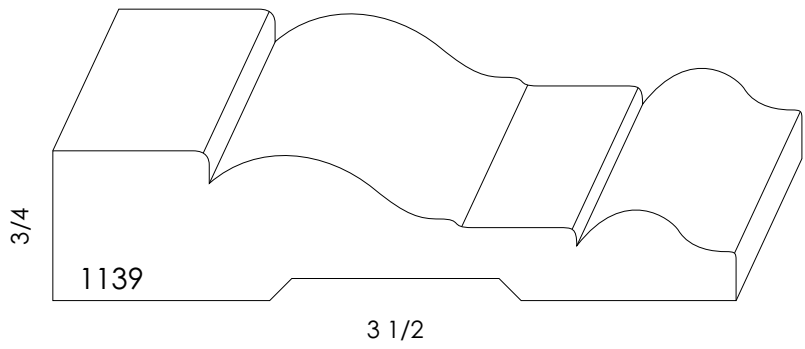
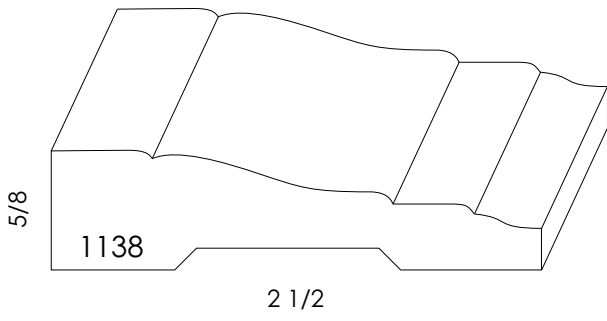
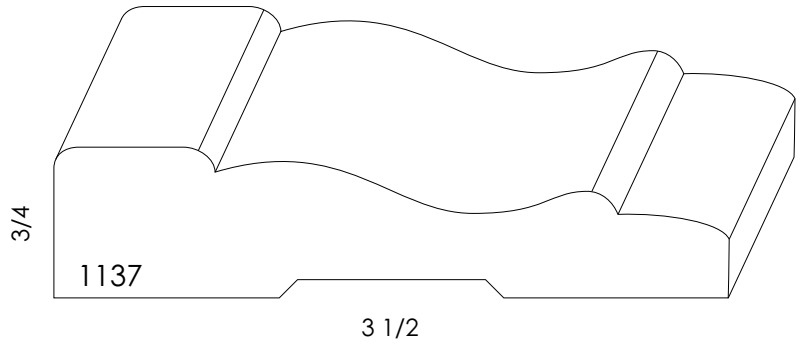
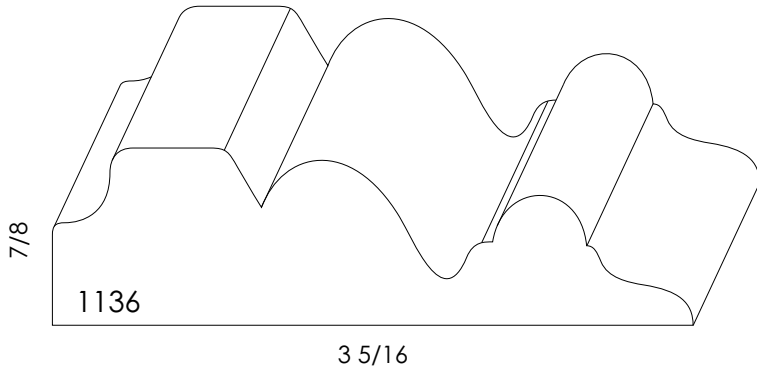

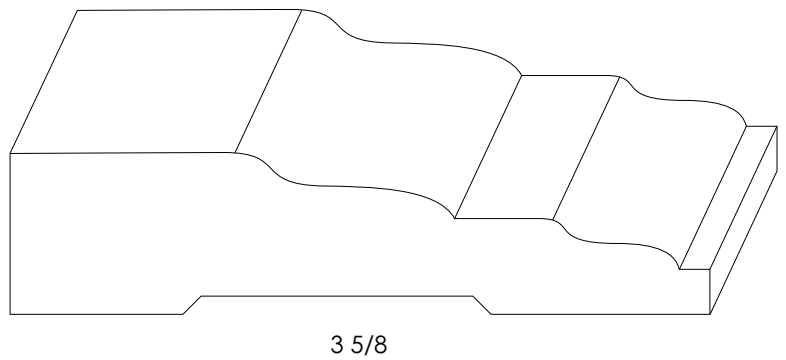
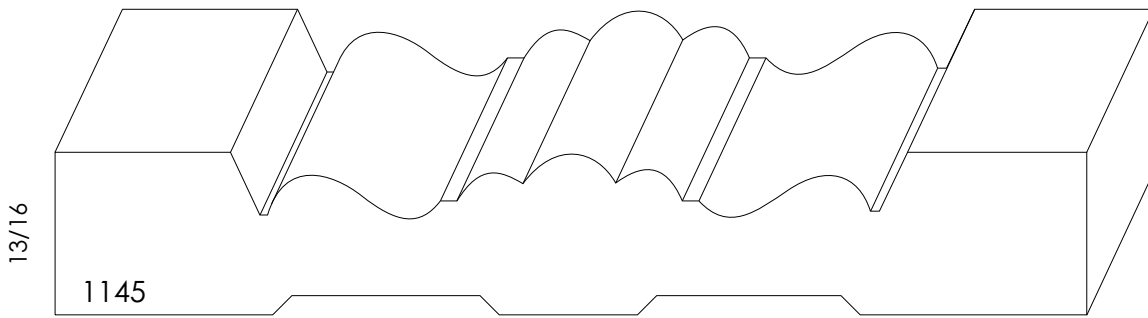
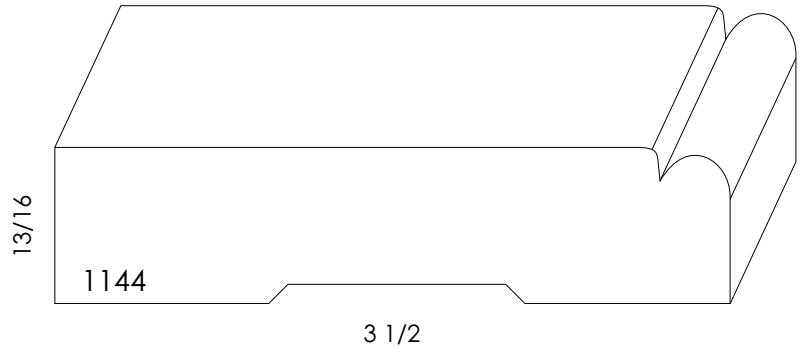
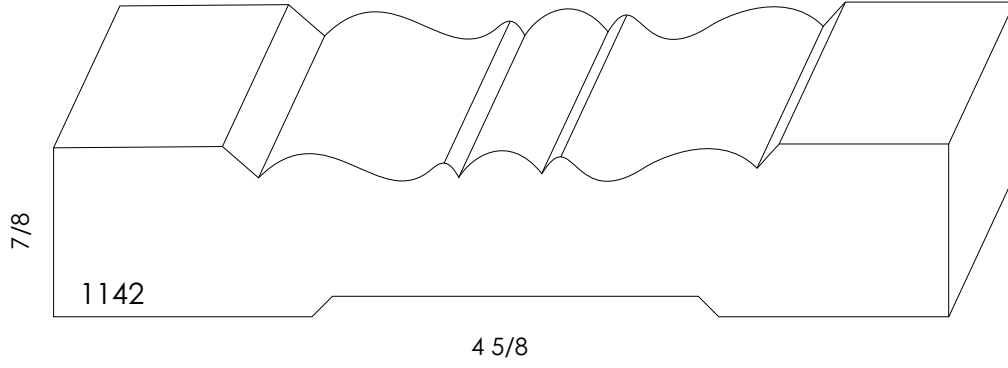
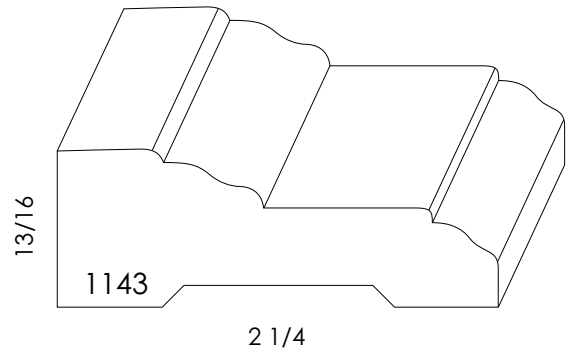
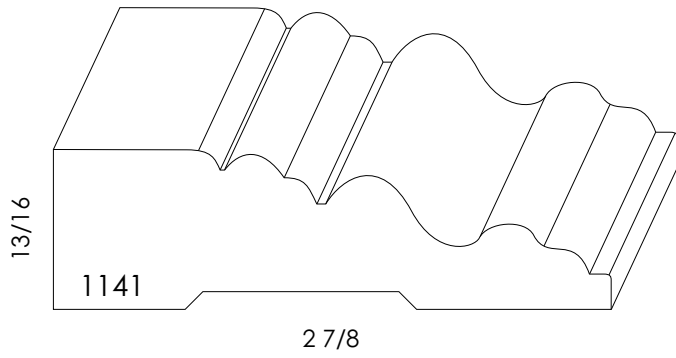

Base

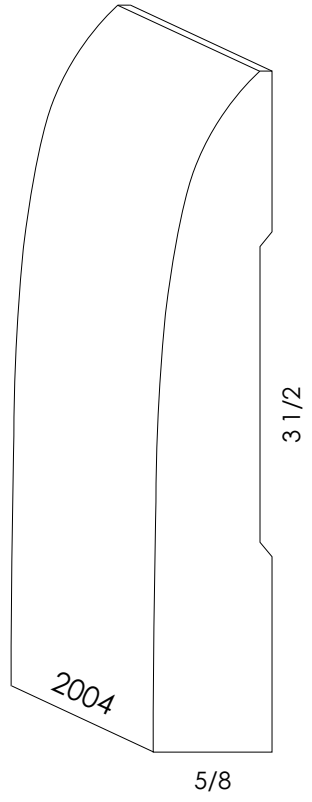
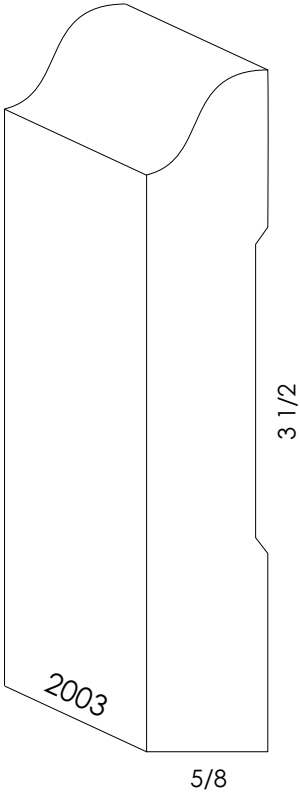
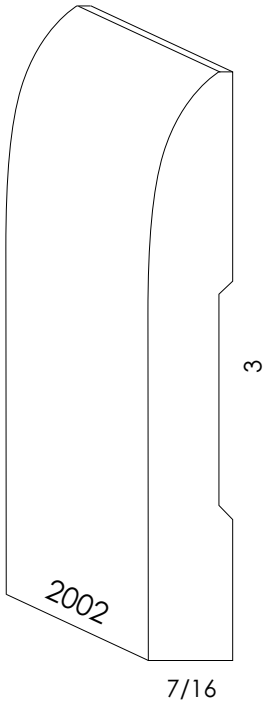
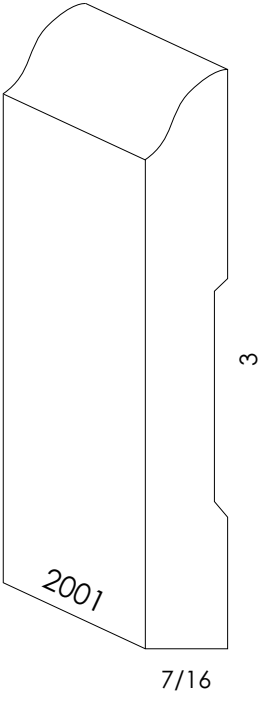

Most baseboards can be modified for height.

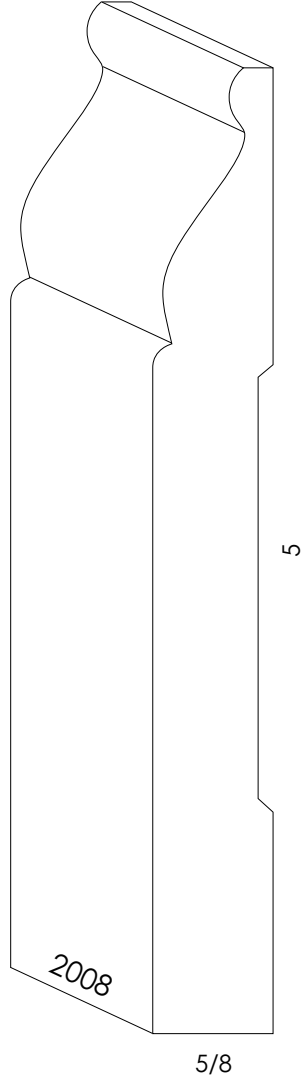
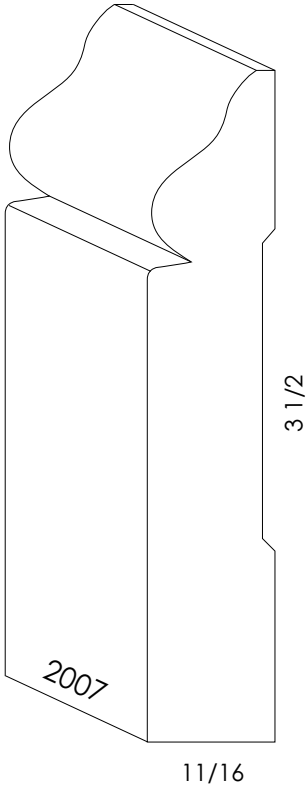
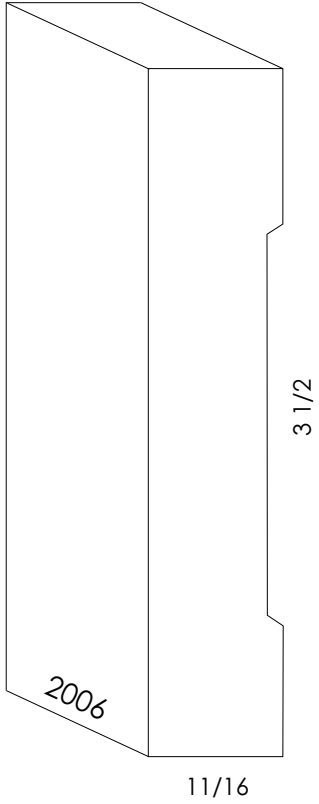
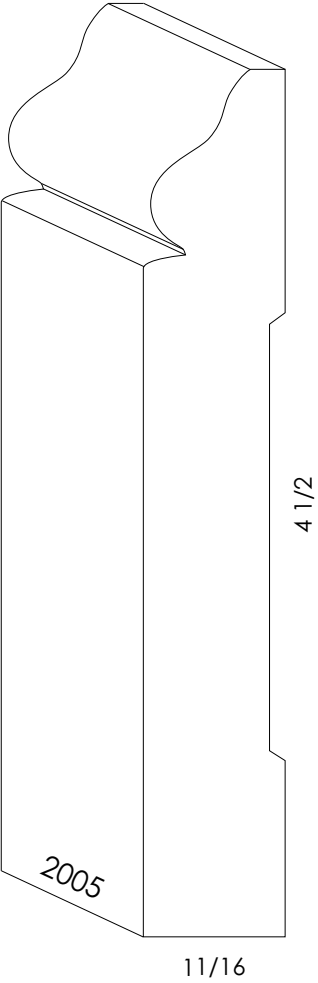

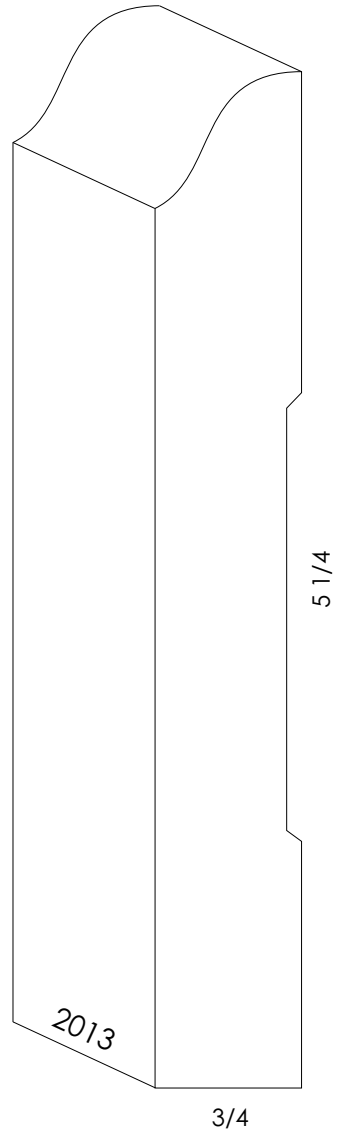
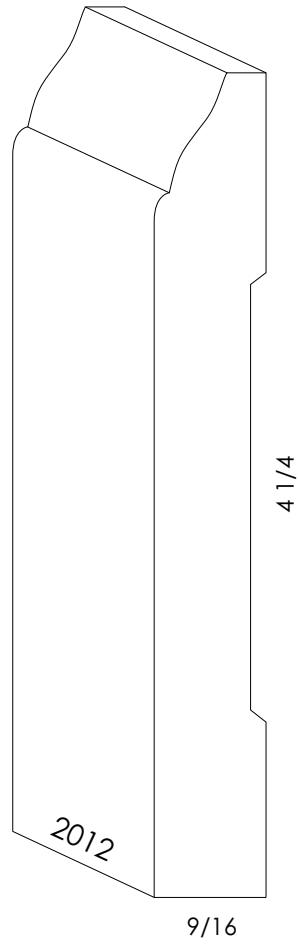
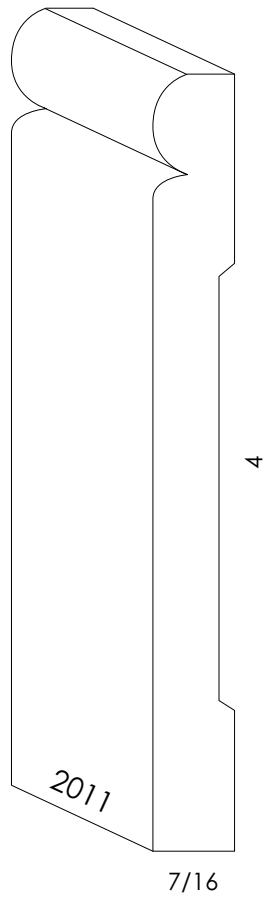
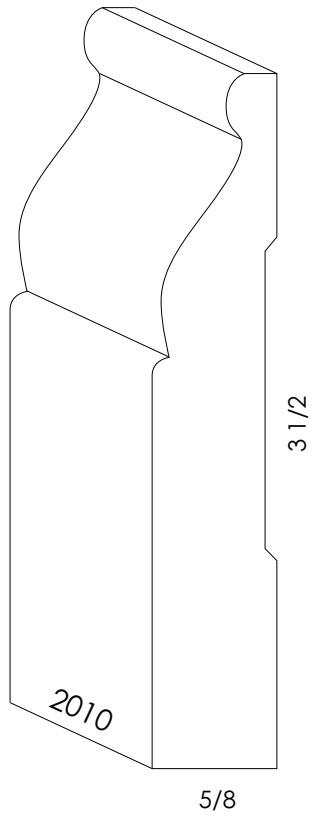
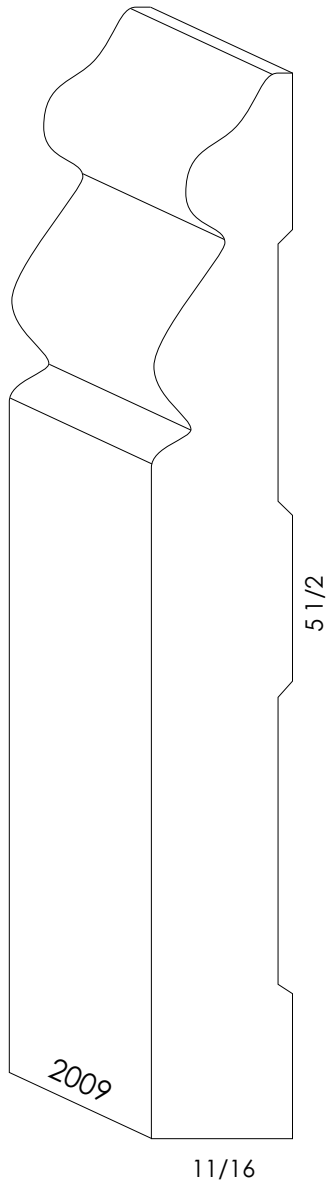

Base

Base

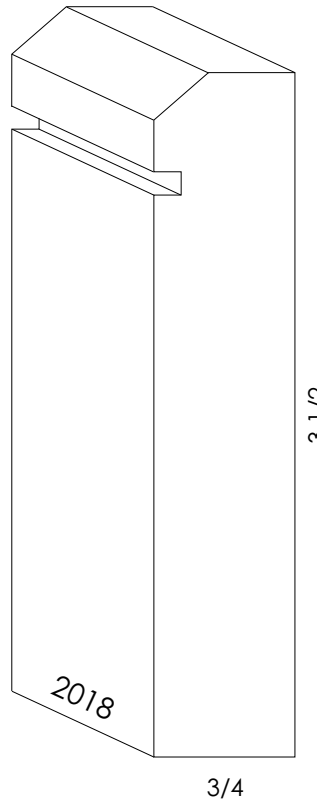
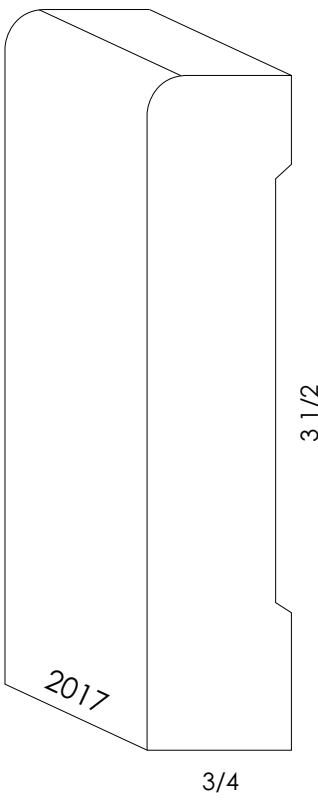
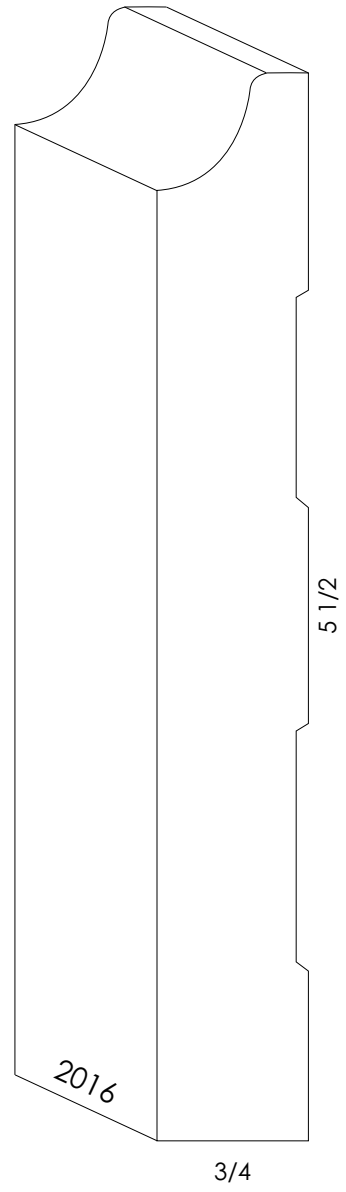
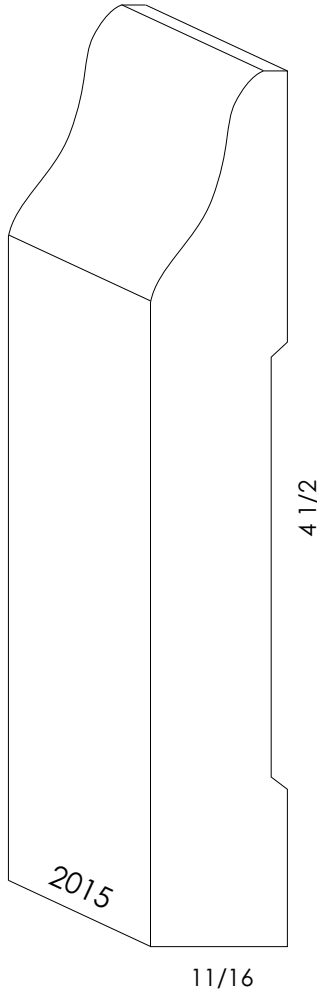
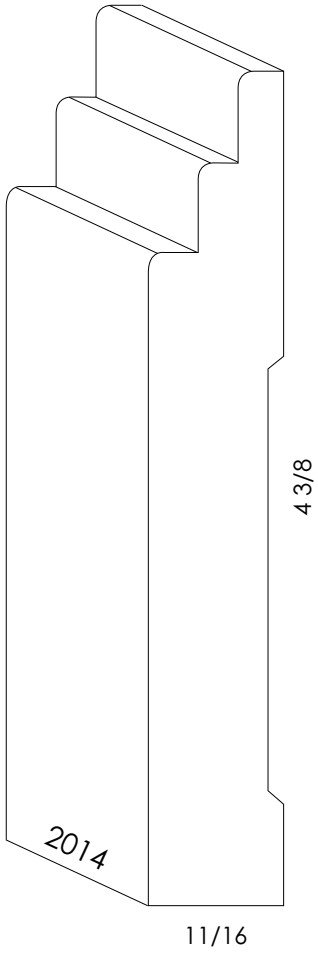

Most baseboards can be modified for height.

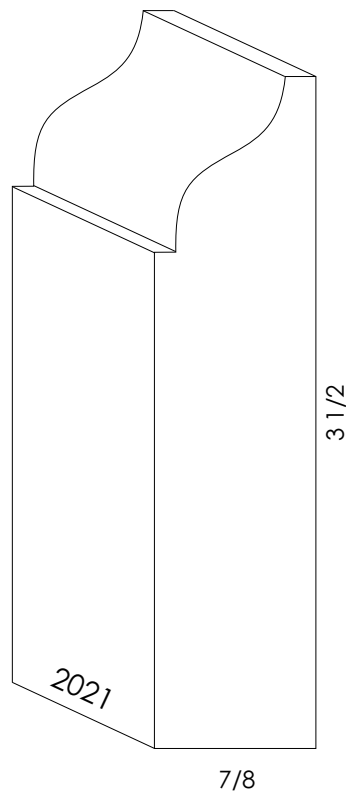
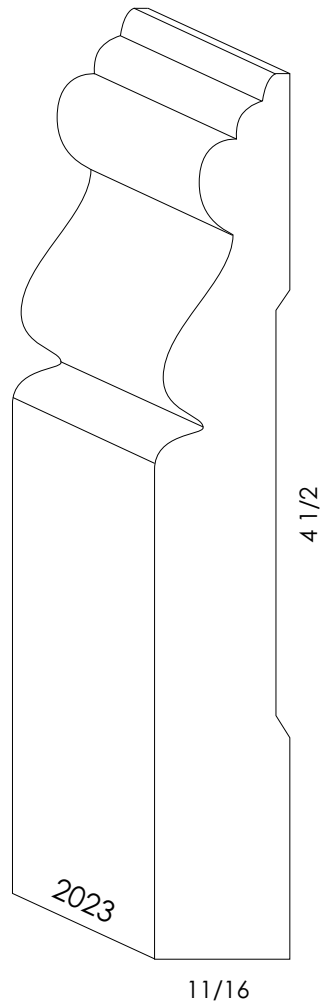
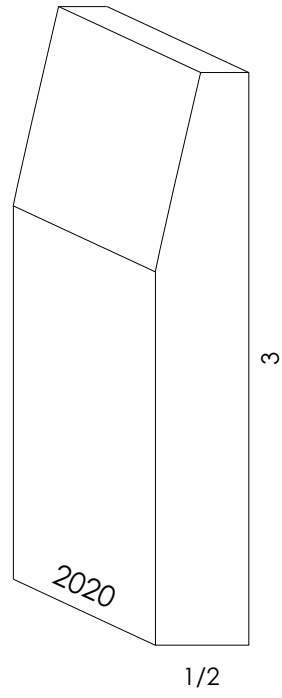
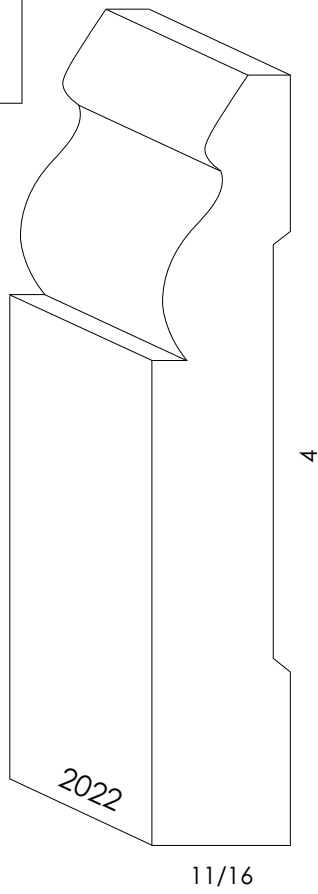
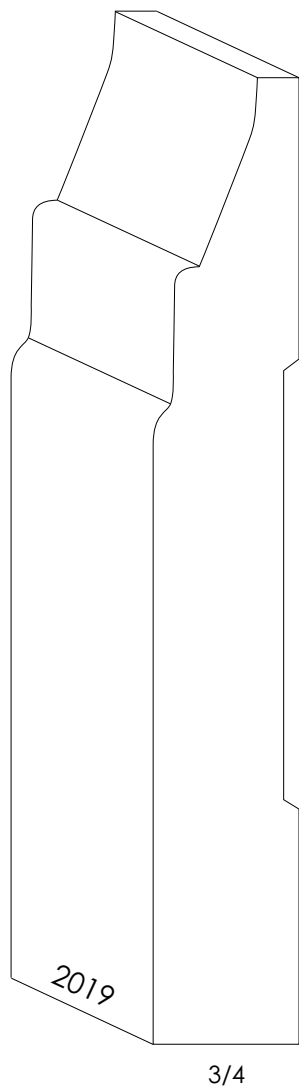

Base

7 1/2

Base

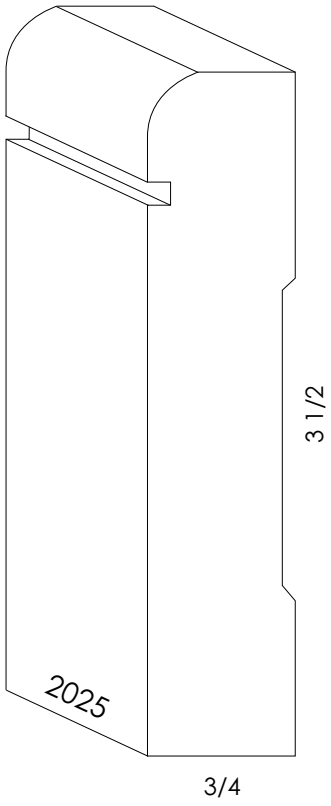

Most baseboards can be modified for height.

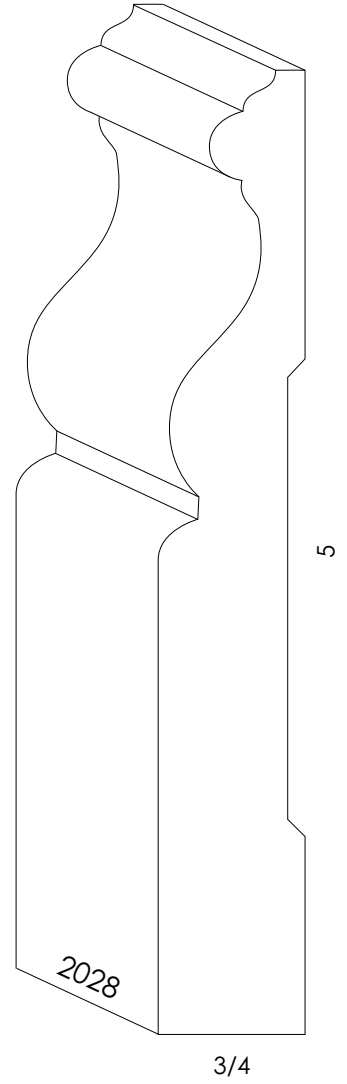
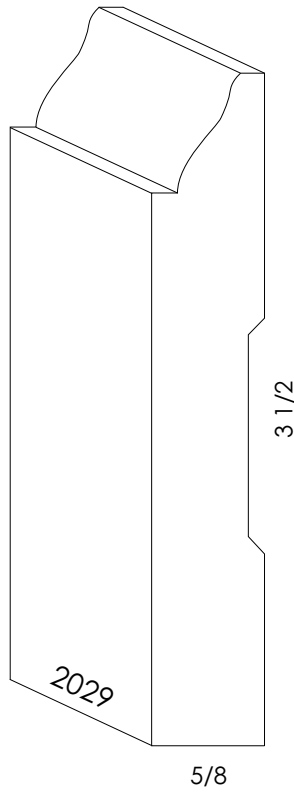
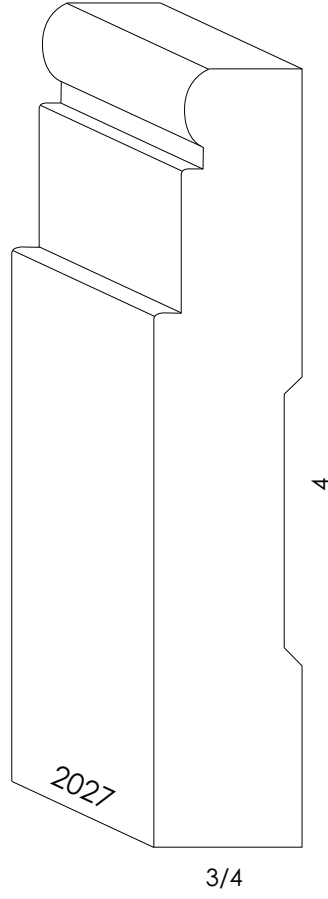
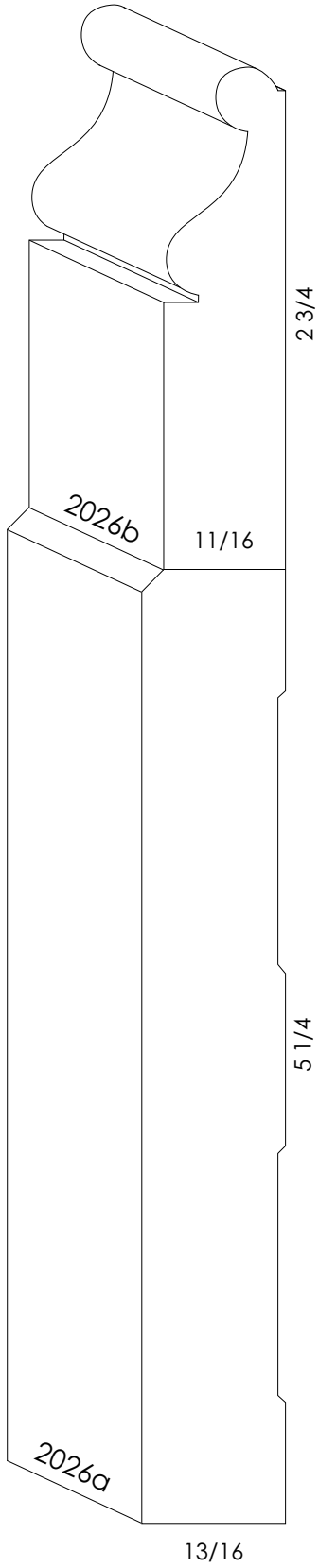

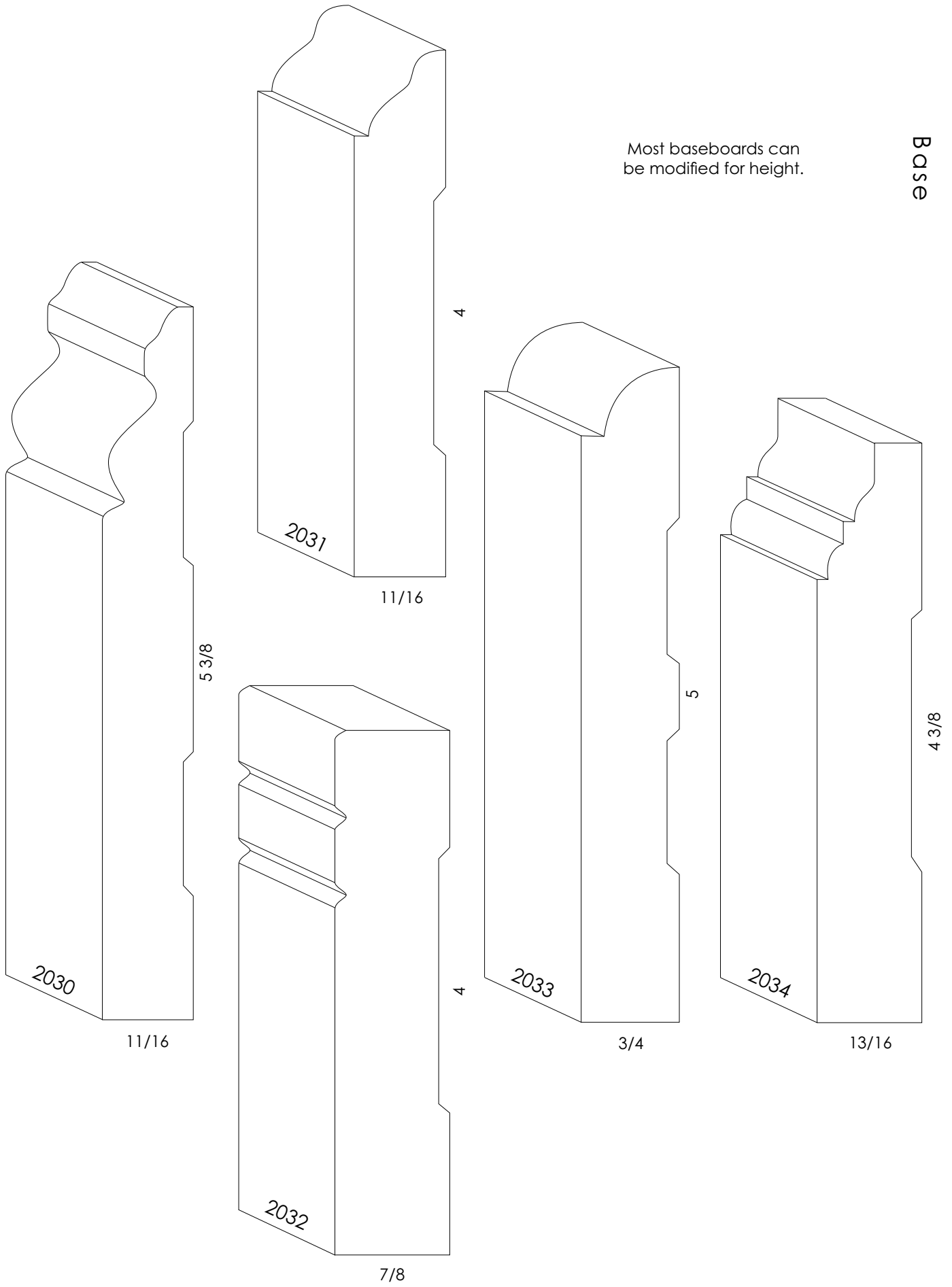

Base

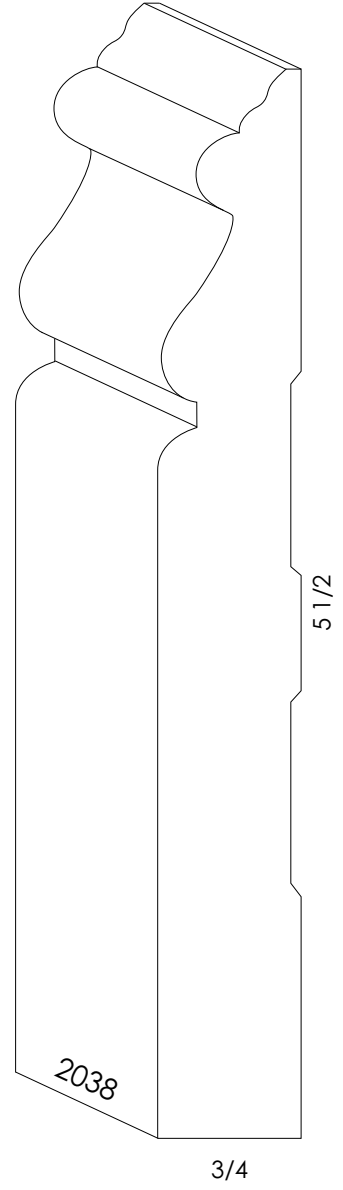
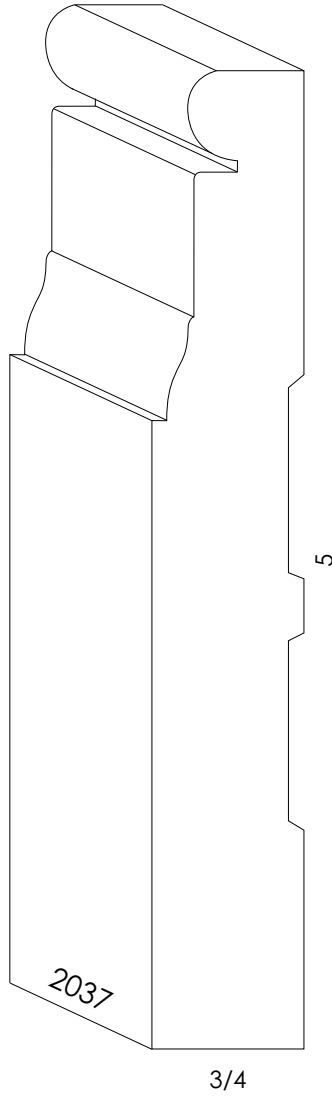
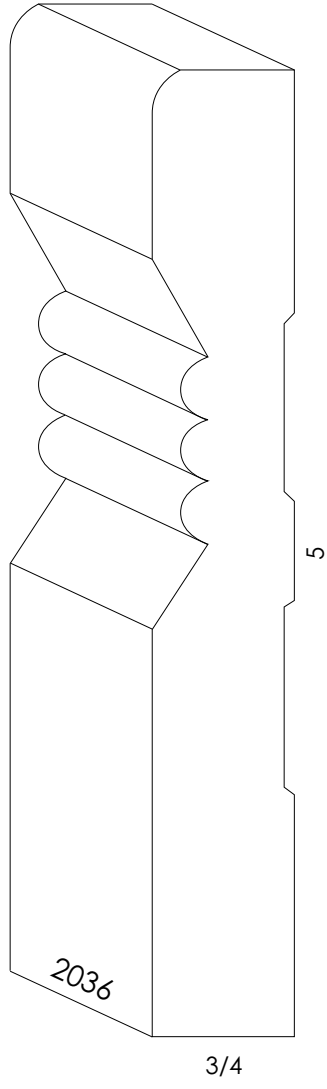
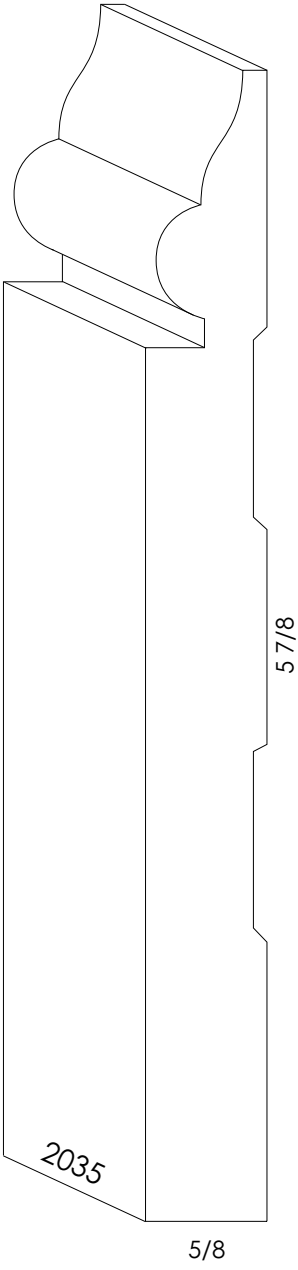

Most baseboards can be modified for height.

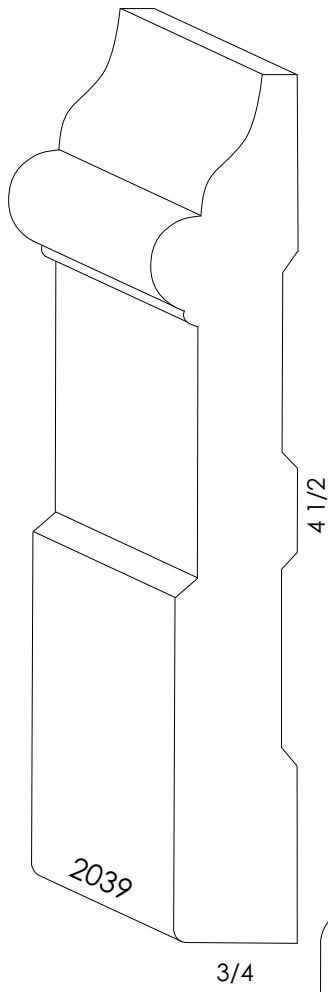

3/4

4 1/2

2039

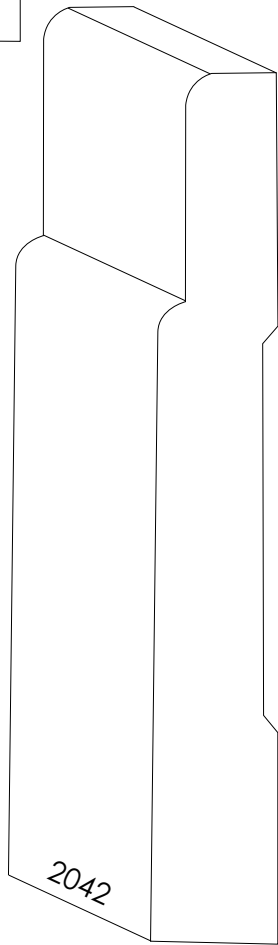

5/8

4 1/2

2042

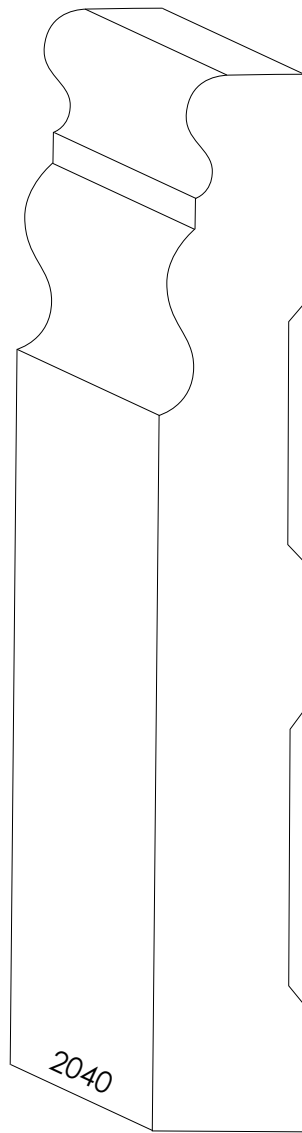

3/4

5 1/2

2040

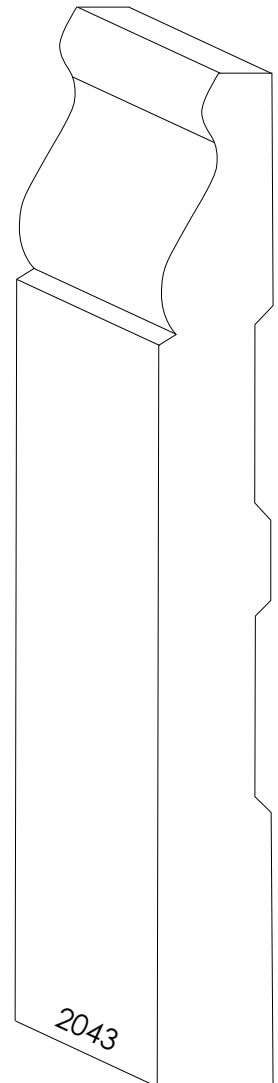

9/16

5 1/4

2043

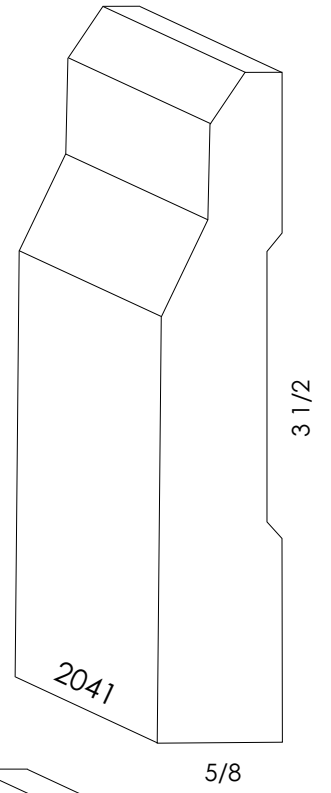

5/8

3 1/2

2041

Base

Base

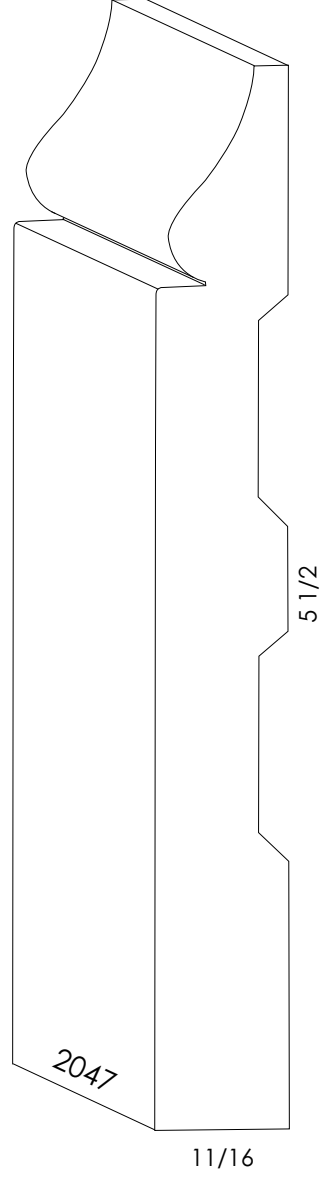
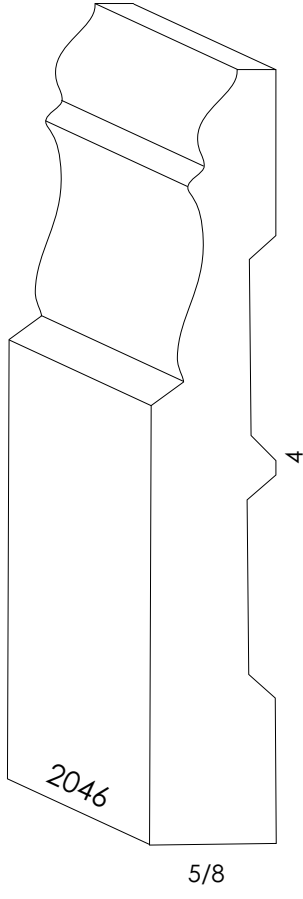
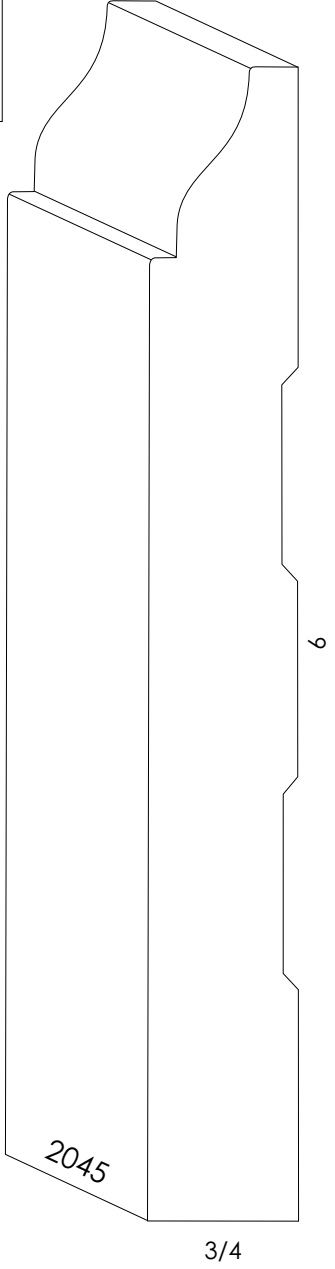
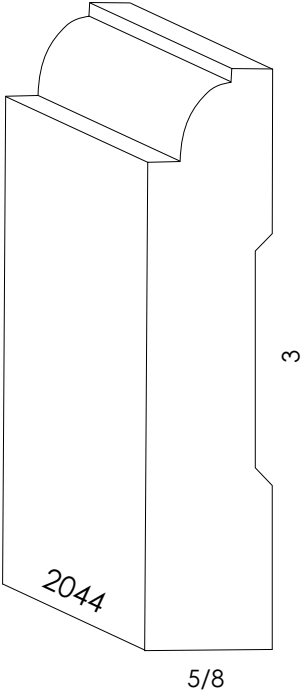

Most baseboards can be modified for height.

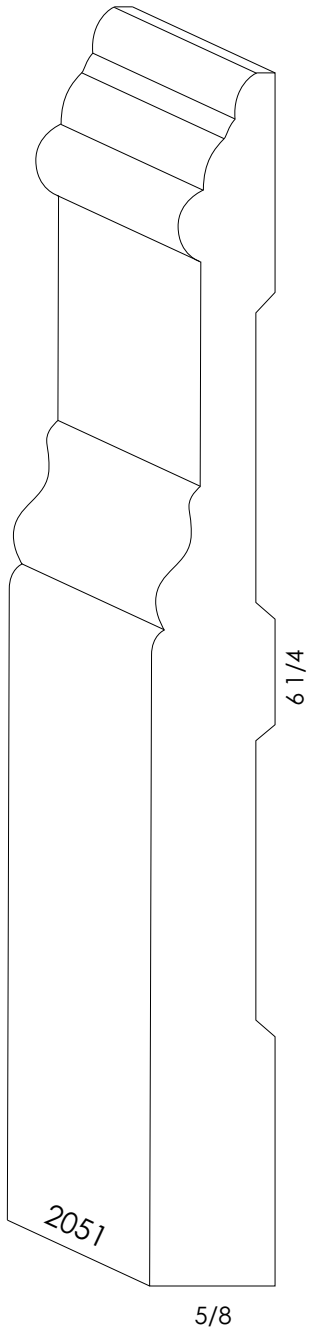
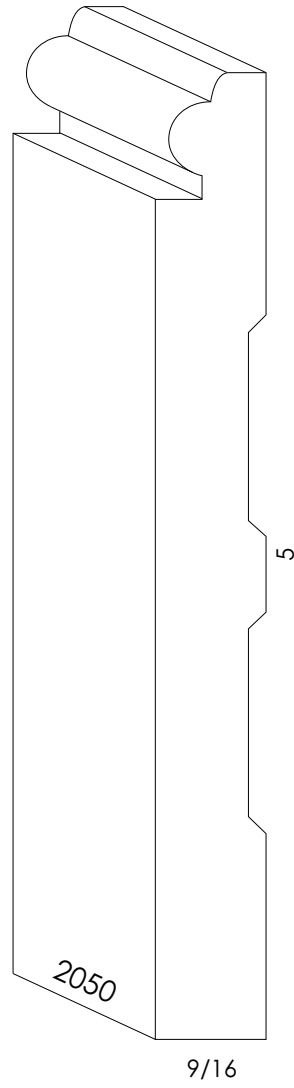
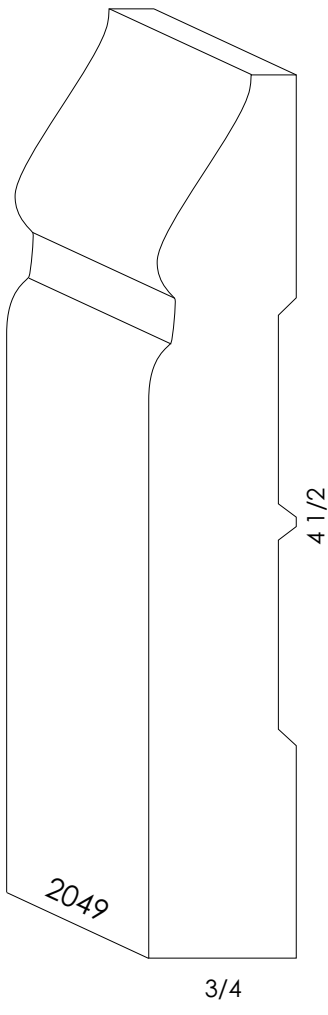
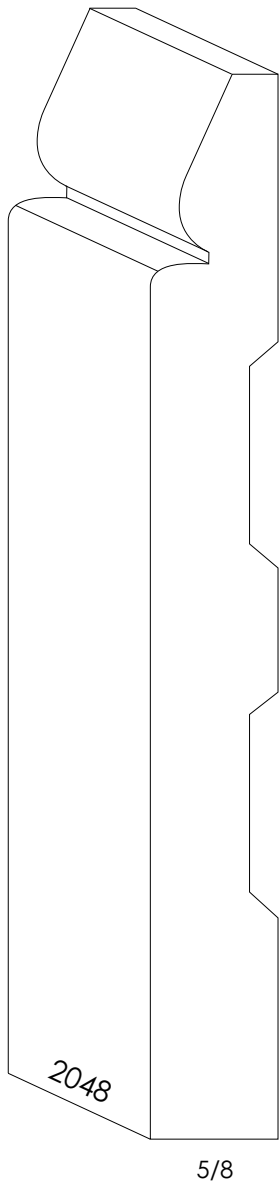

Base

Base

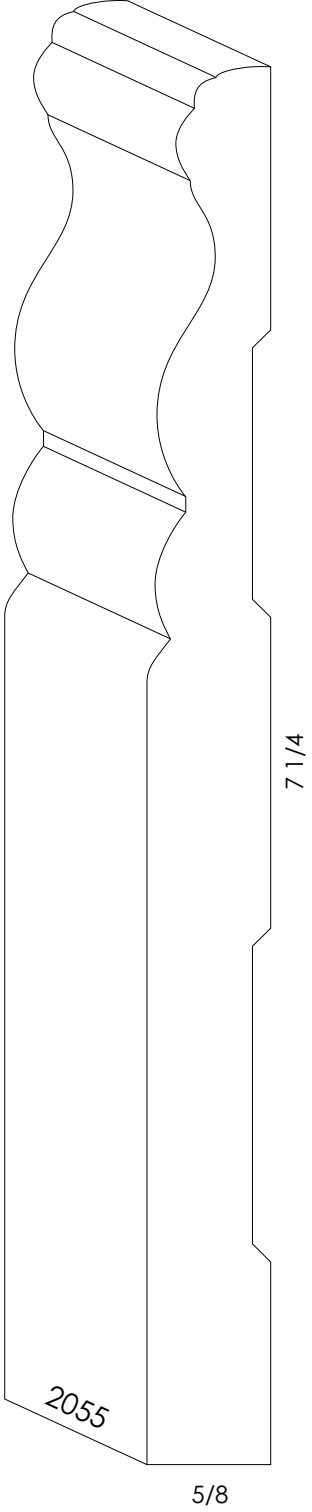
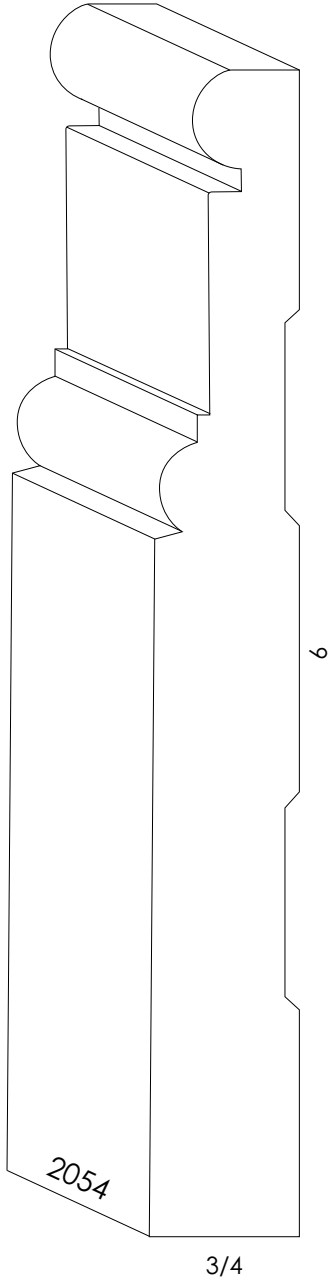
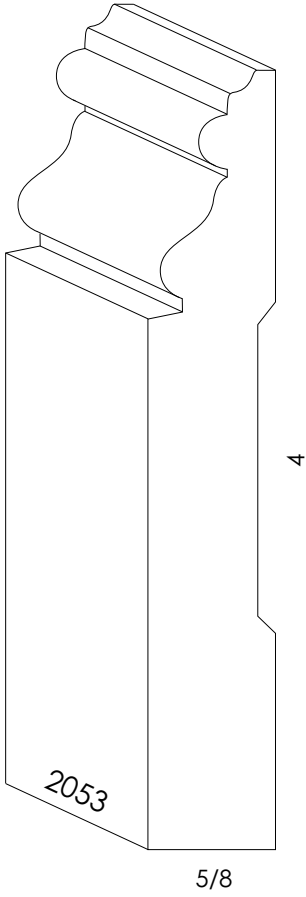
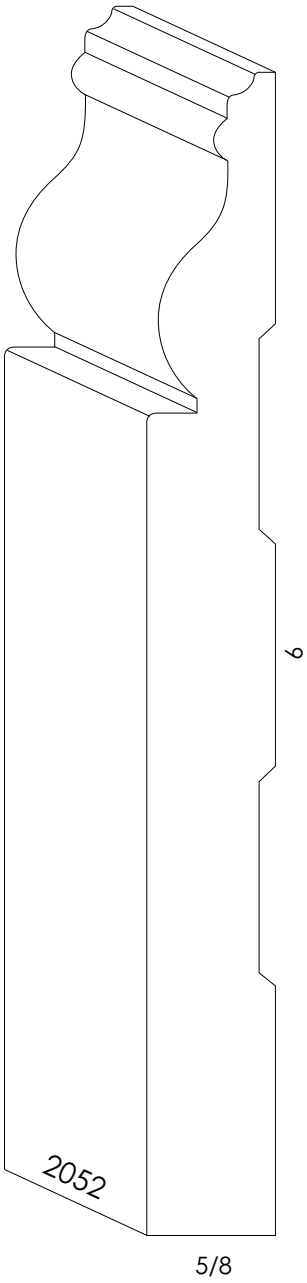

Most baseboards can be modified for height.

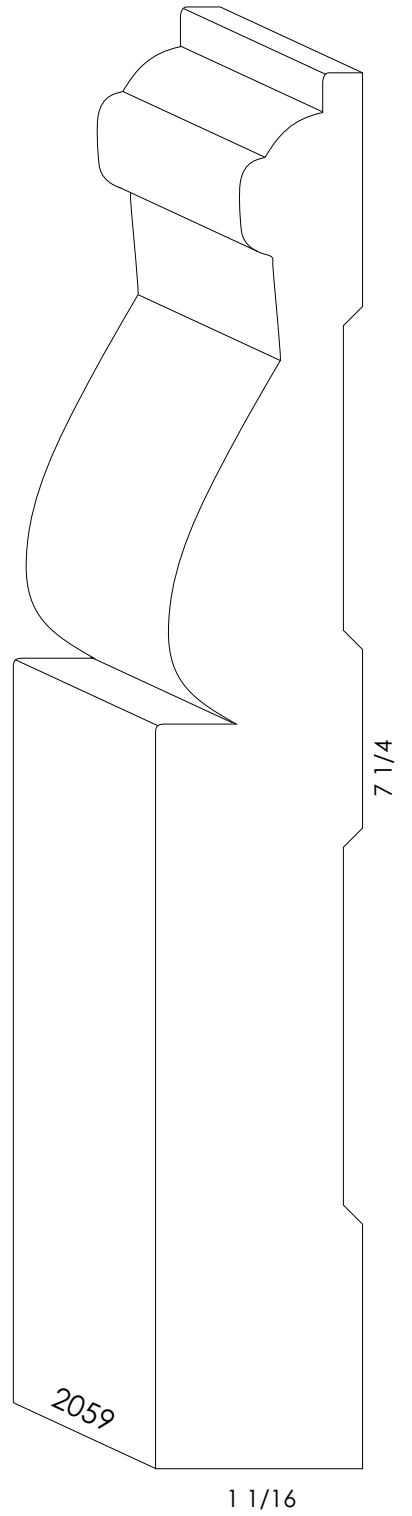
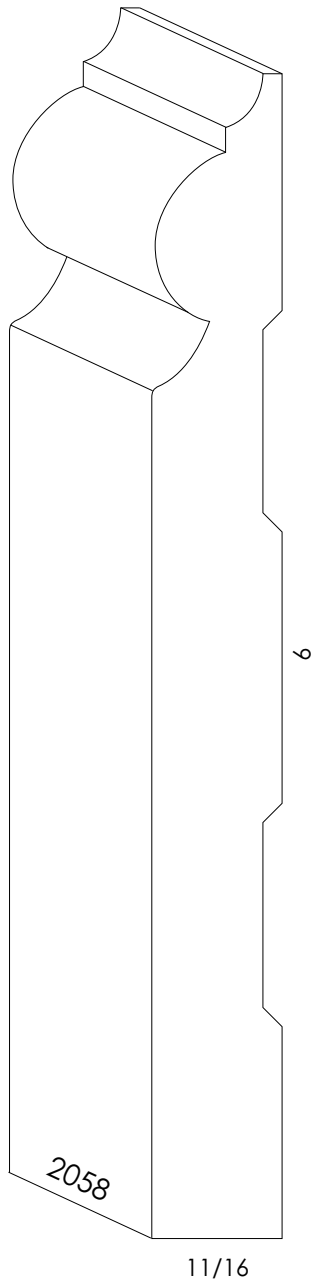
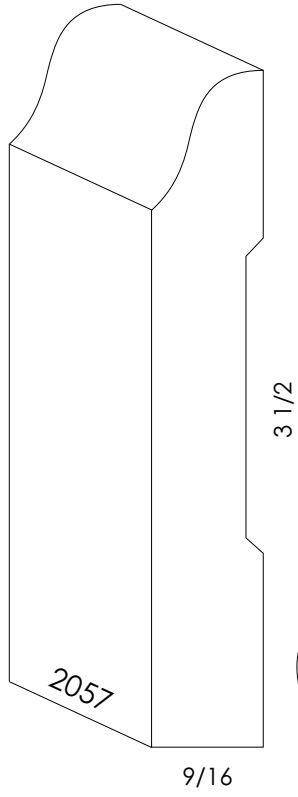
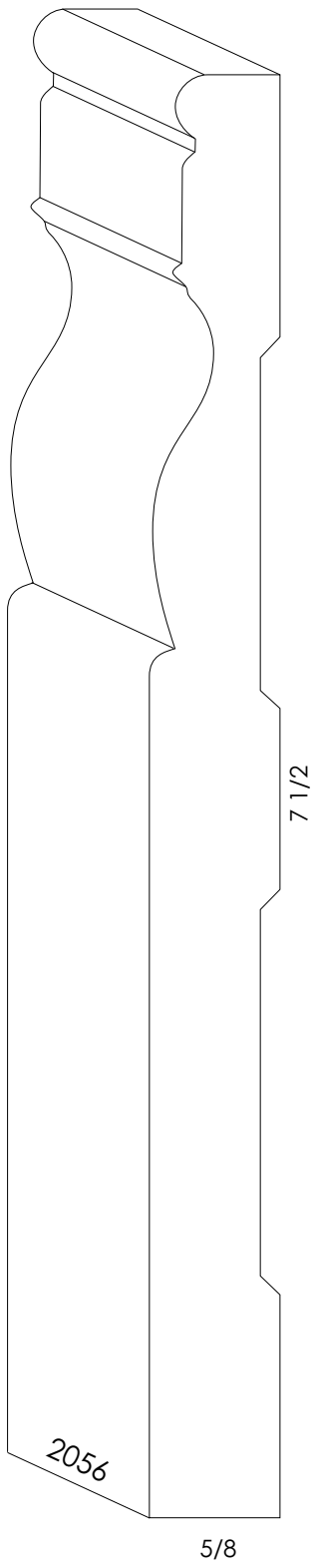

Base

Most baseboards can be modified for height.

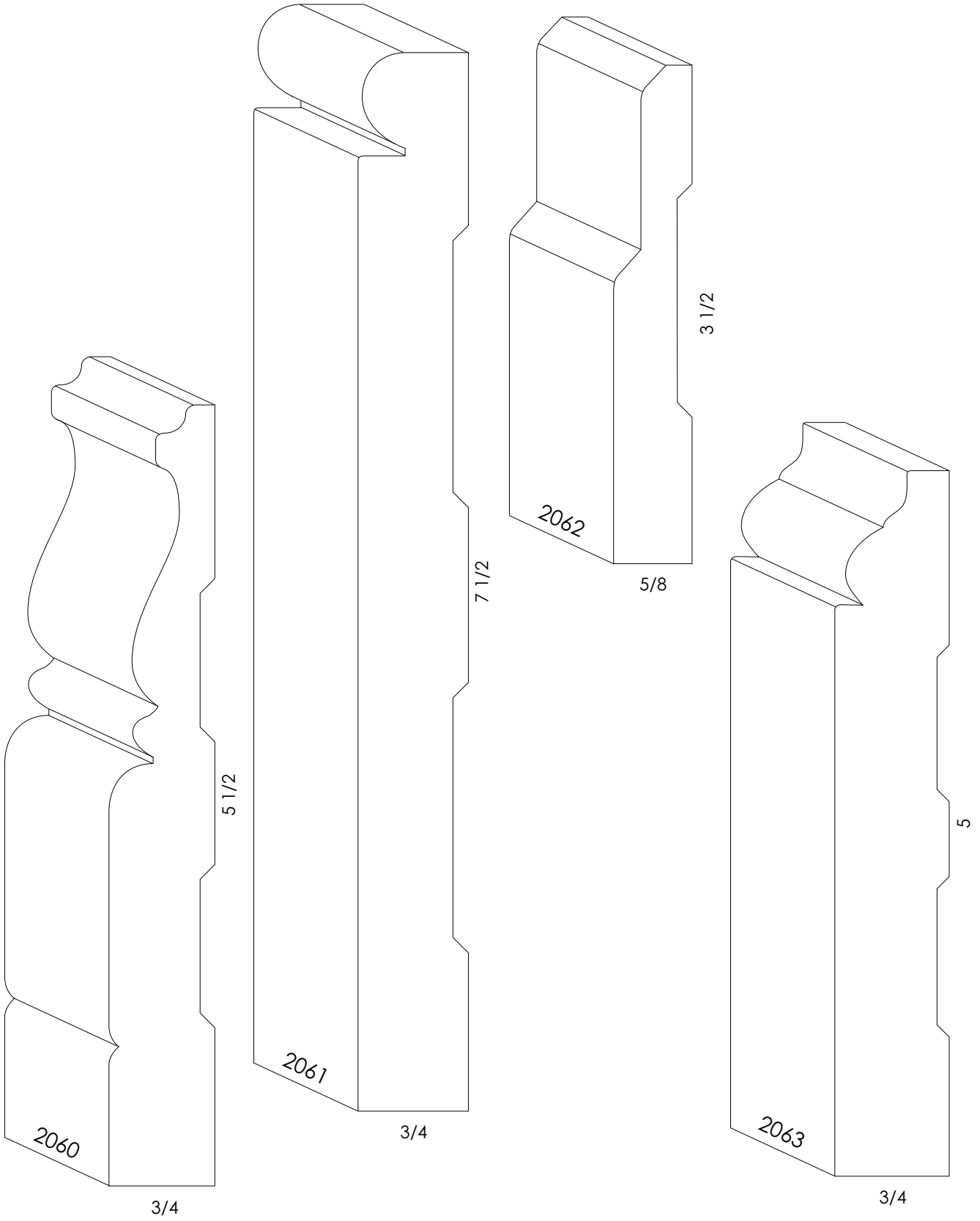

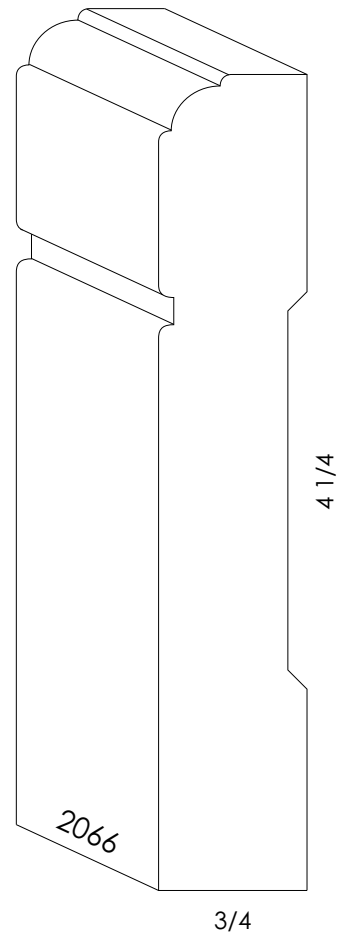
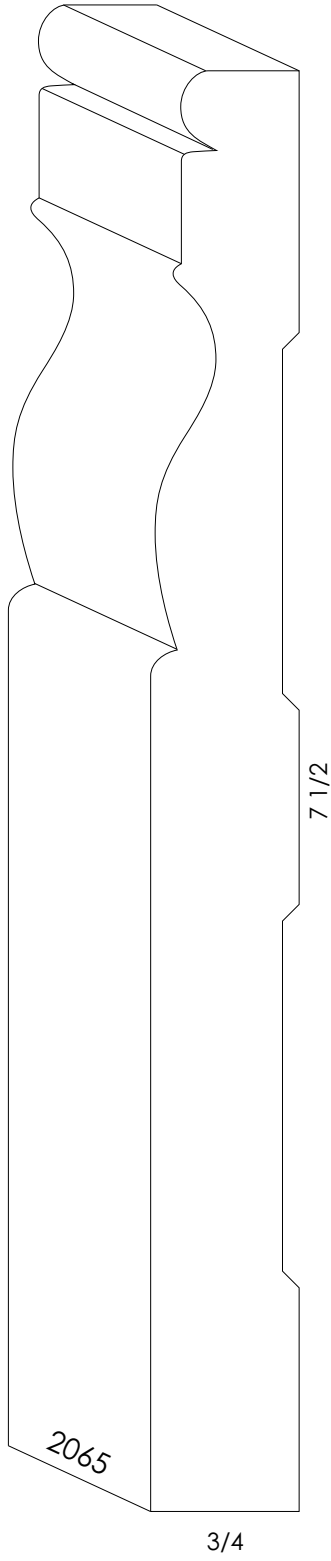
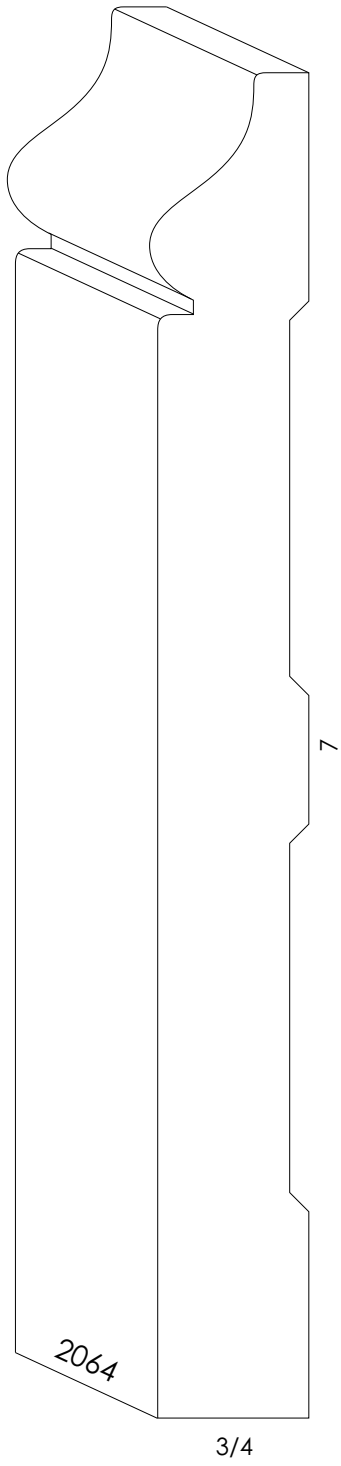

Base

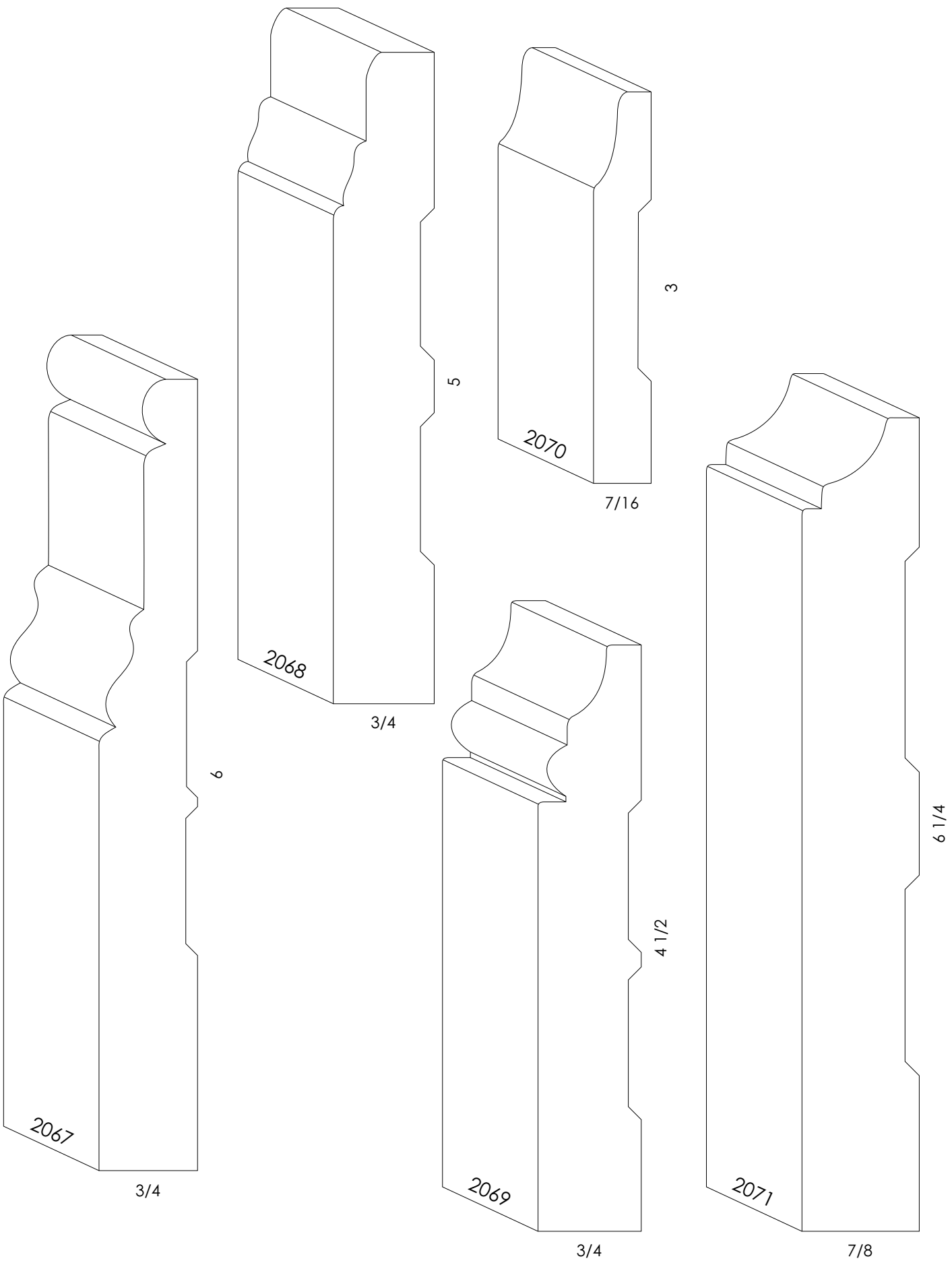

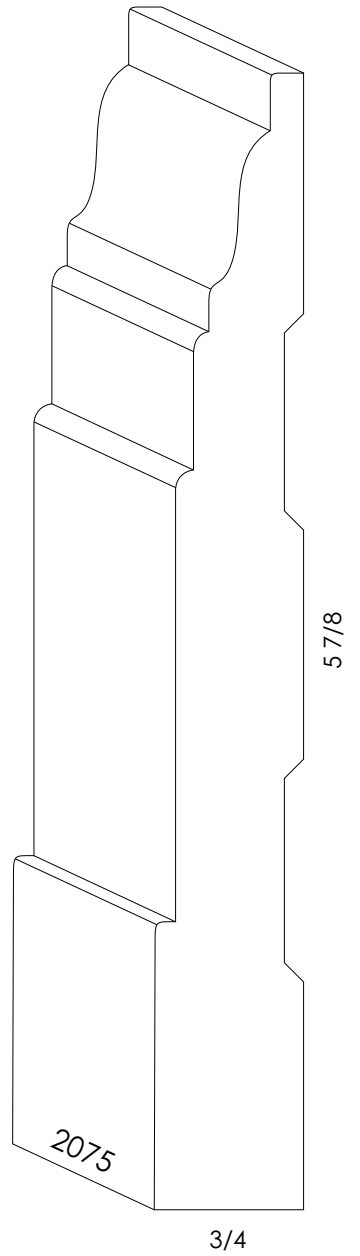
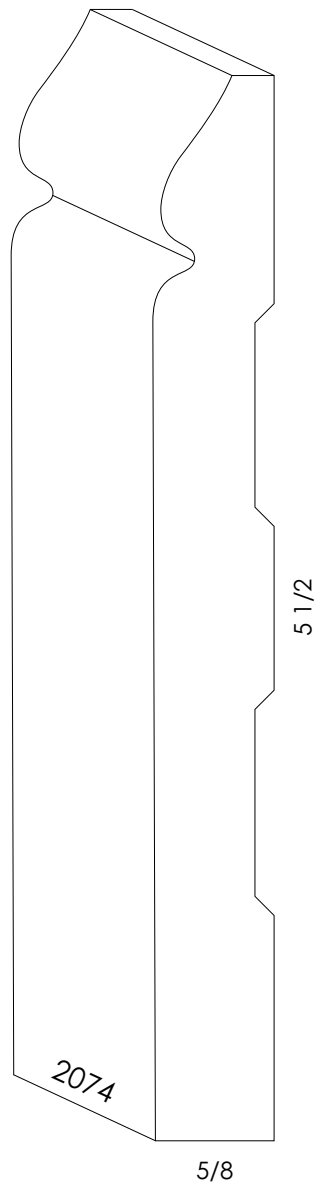
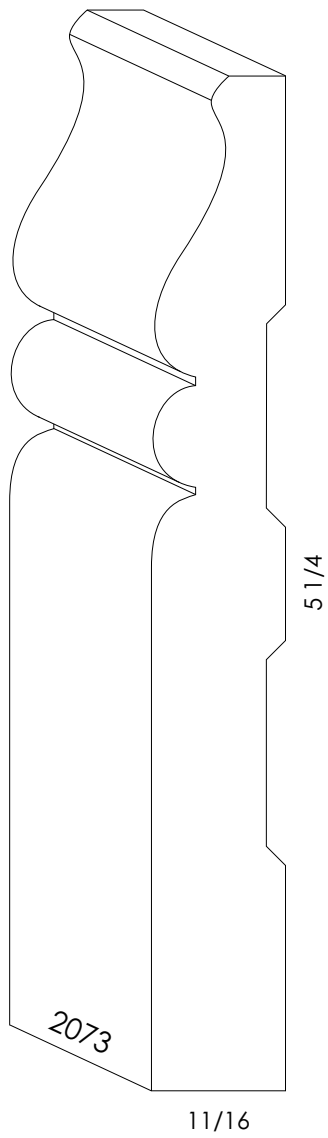
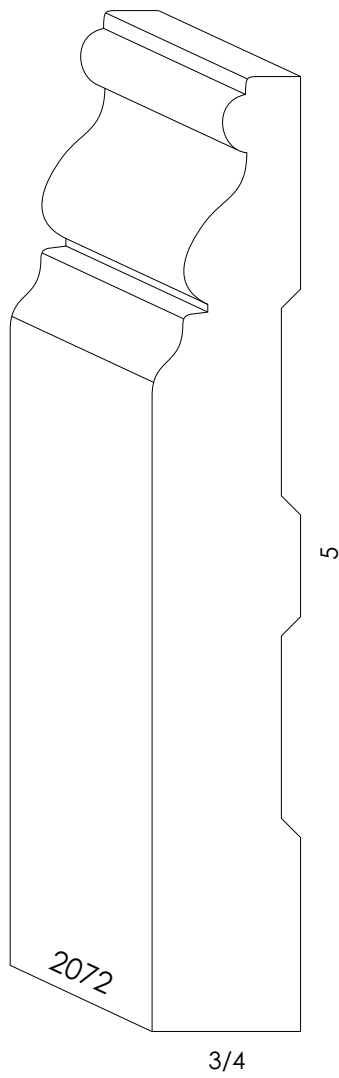

Base

Most baseboards can be modified for height.

Base

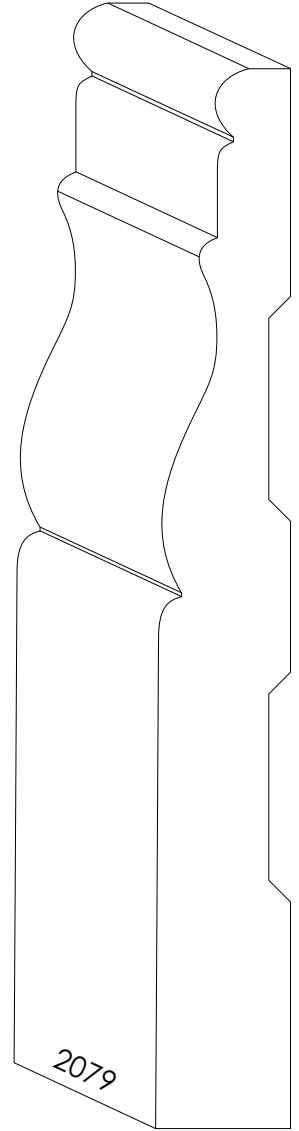
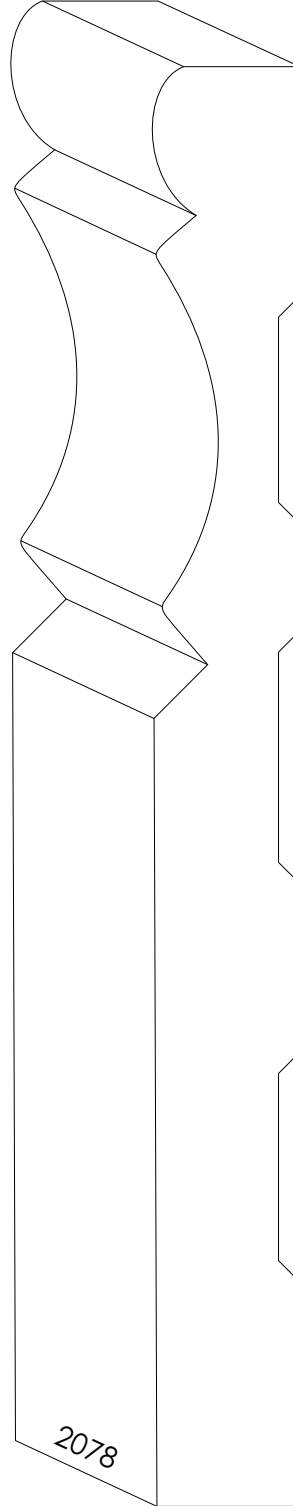
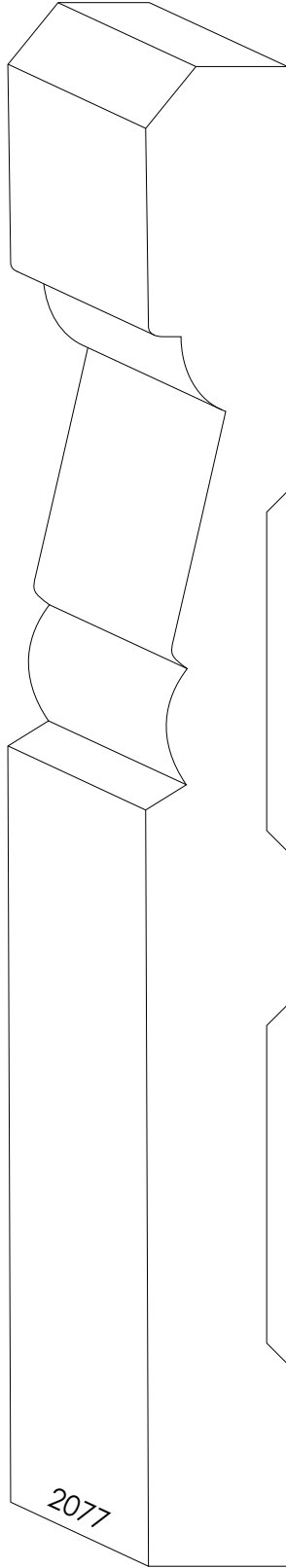
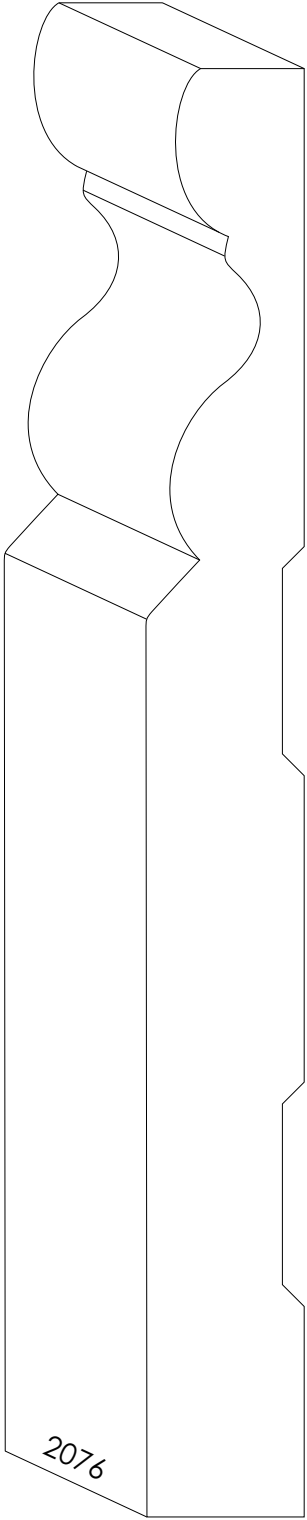

Most baseboards can be modified for height.

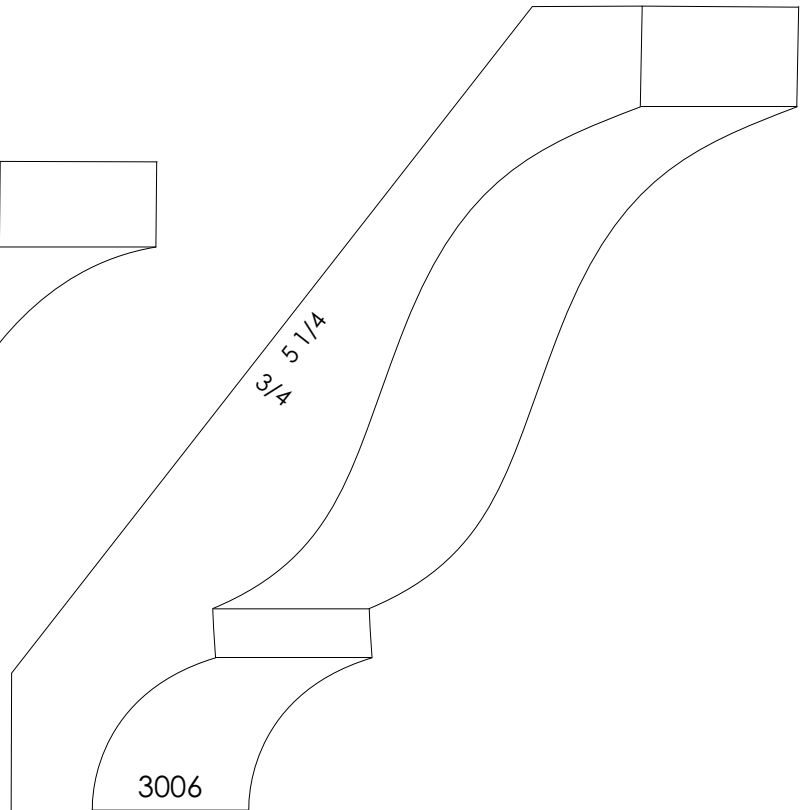
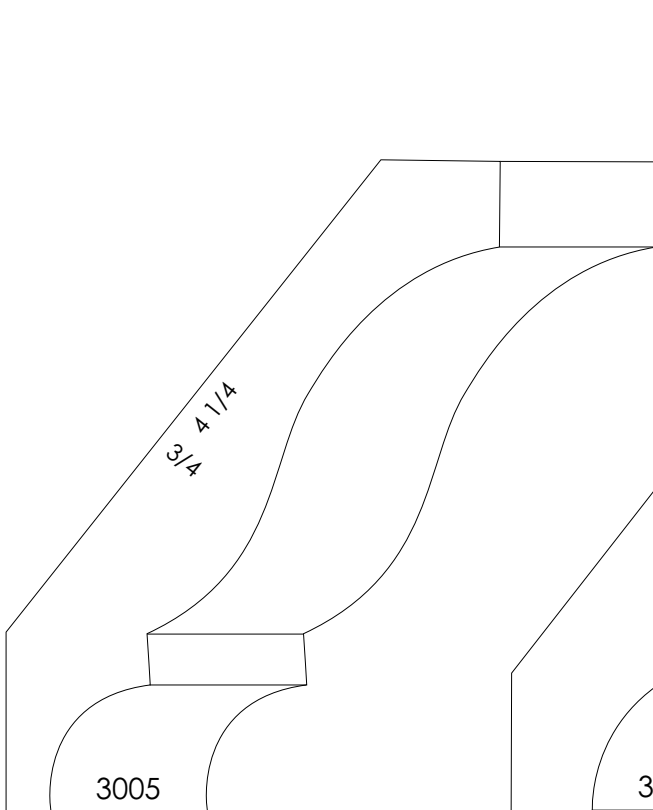
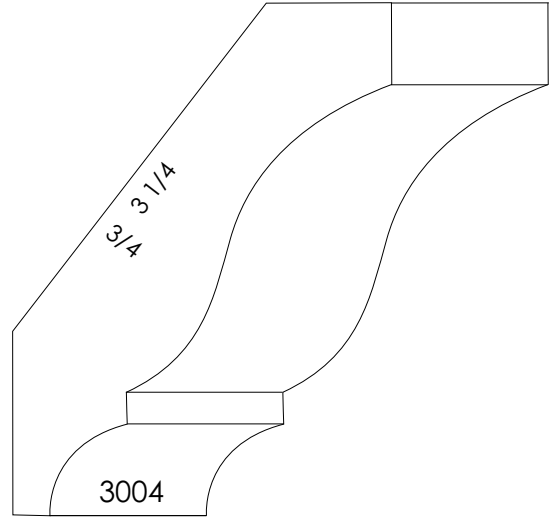
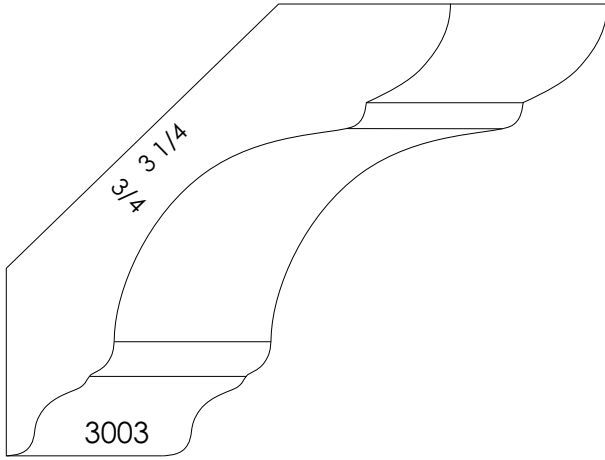
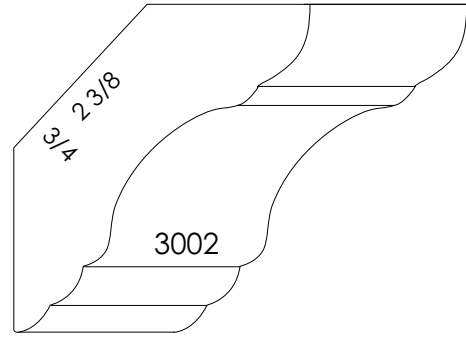
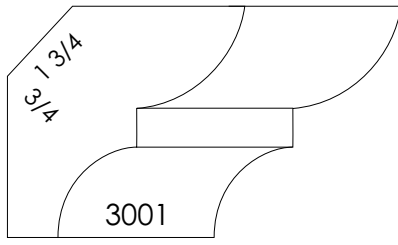

Crown

Crown

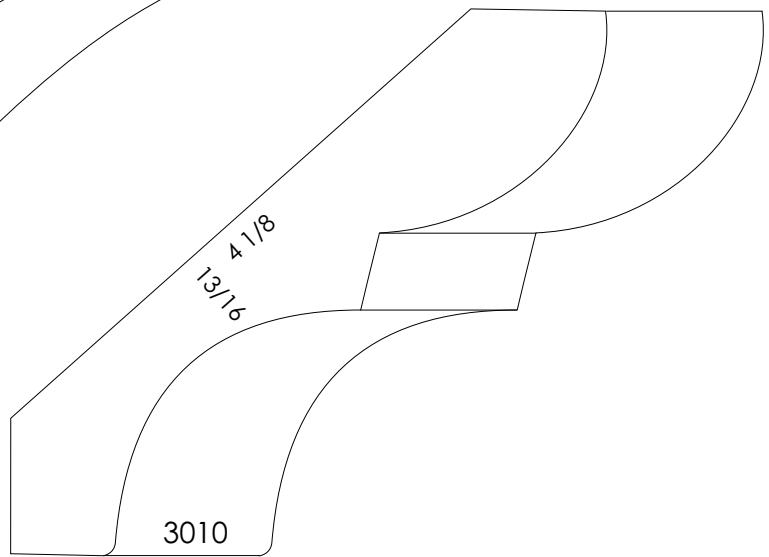
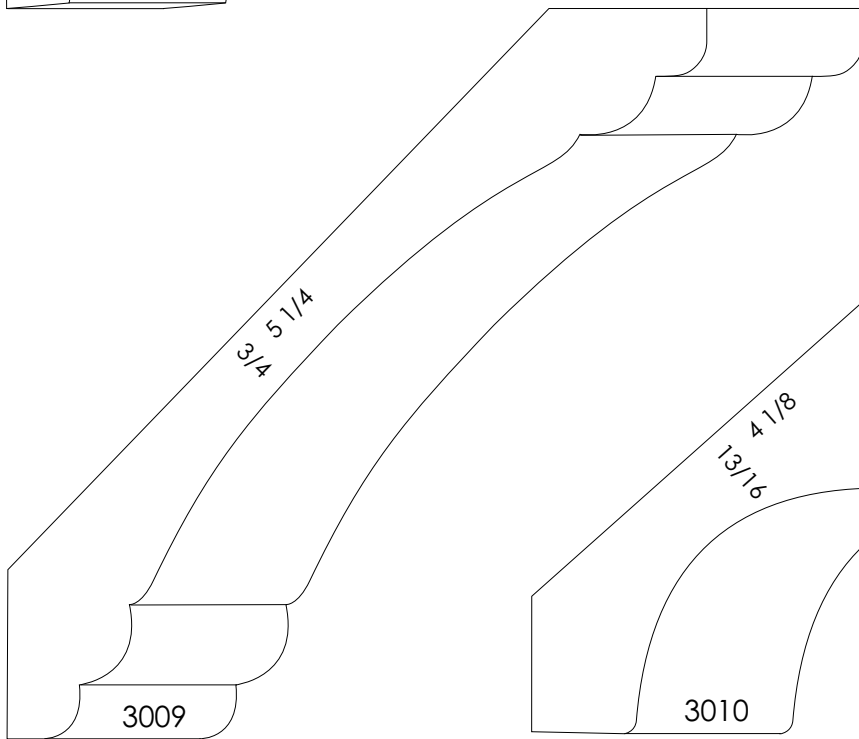
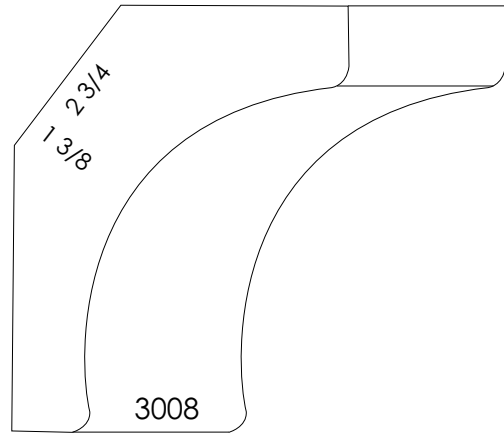
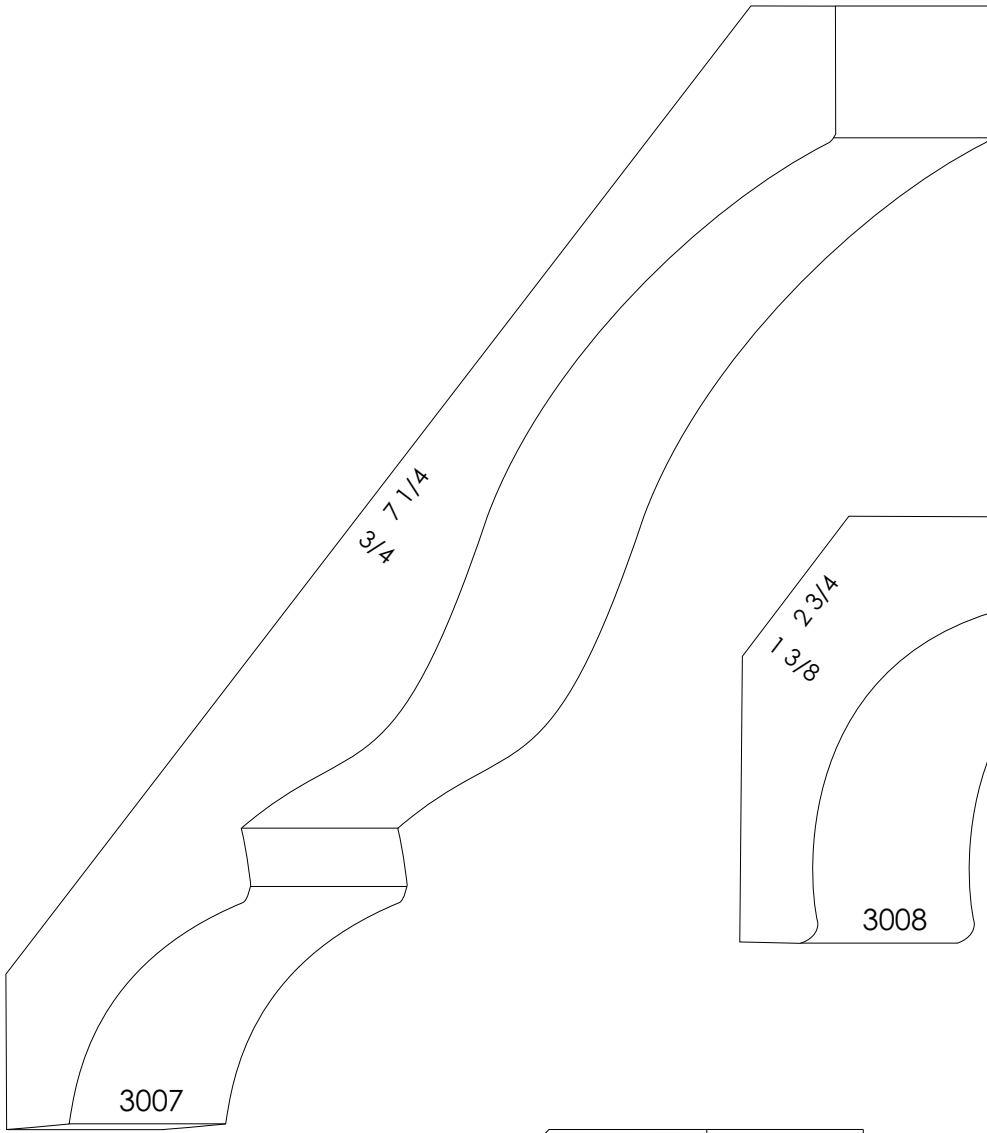

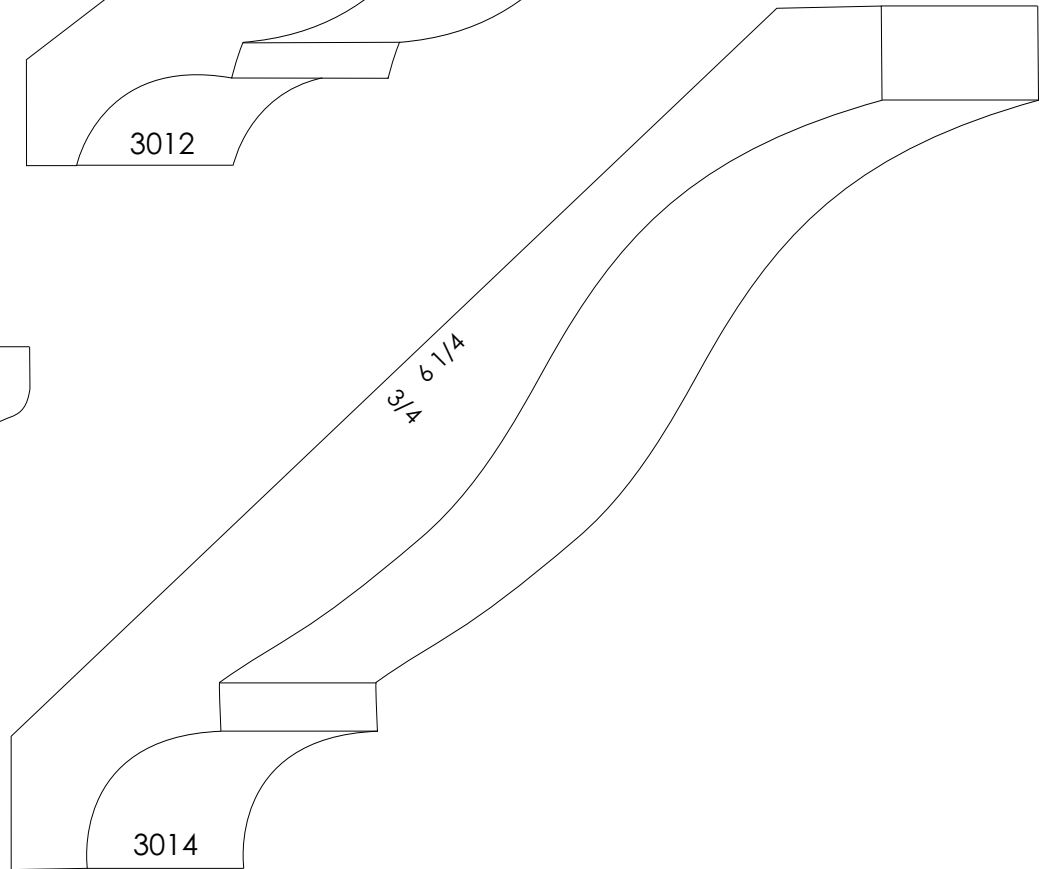
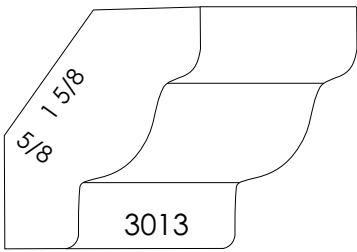
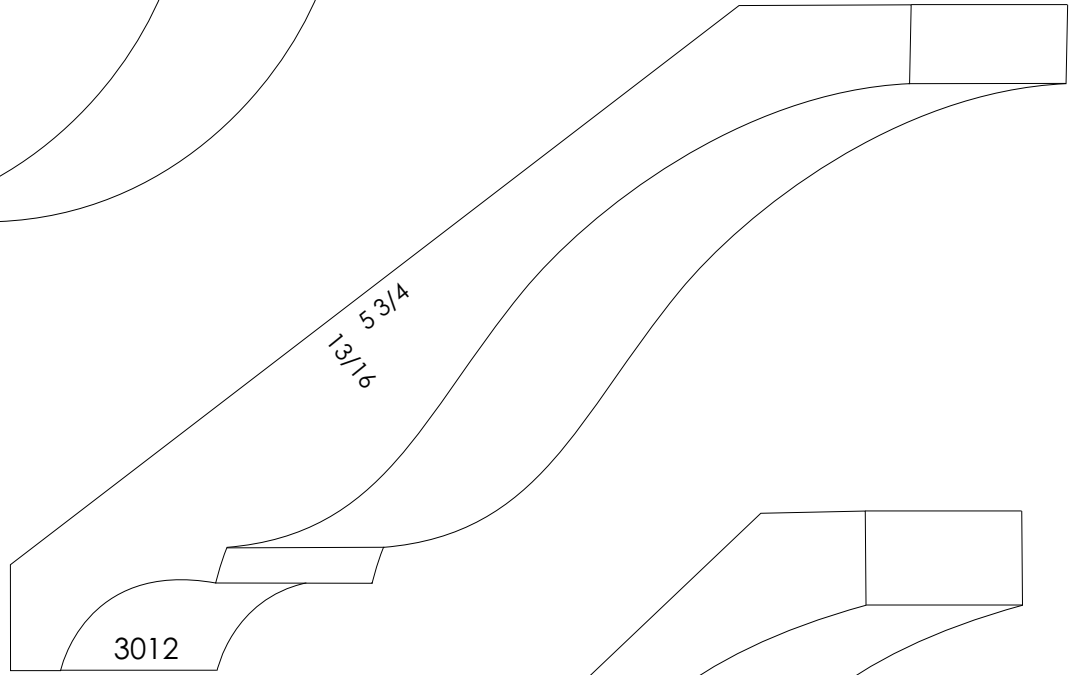
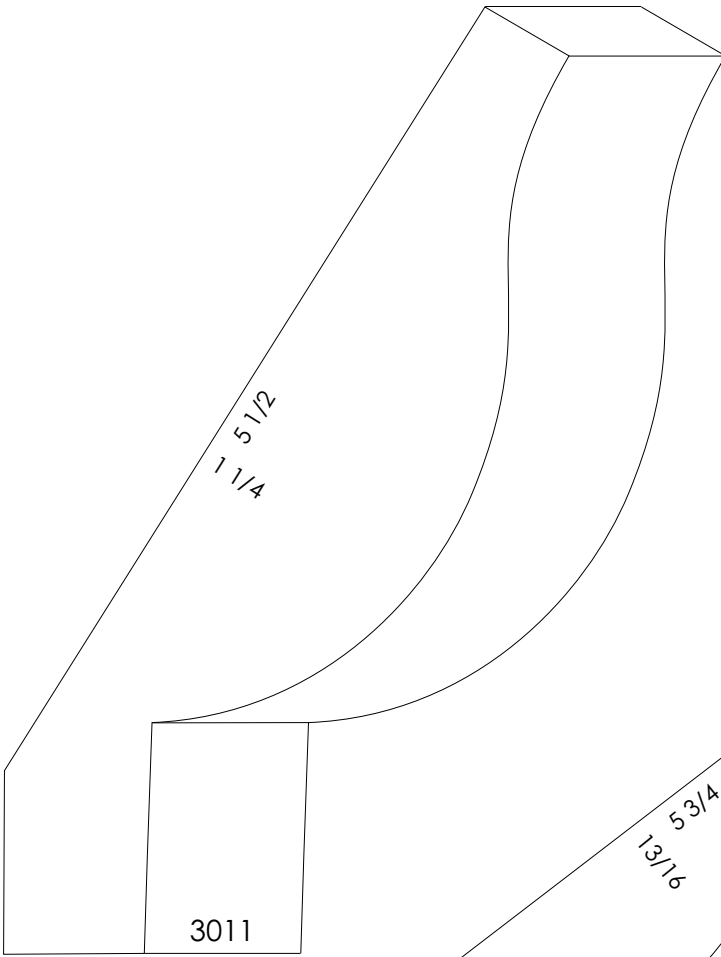

Crown

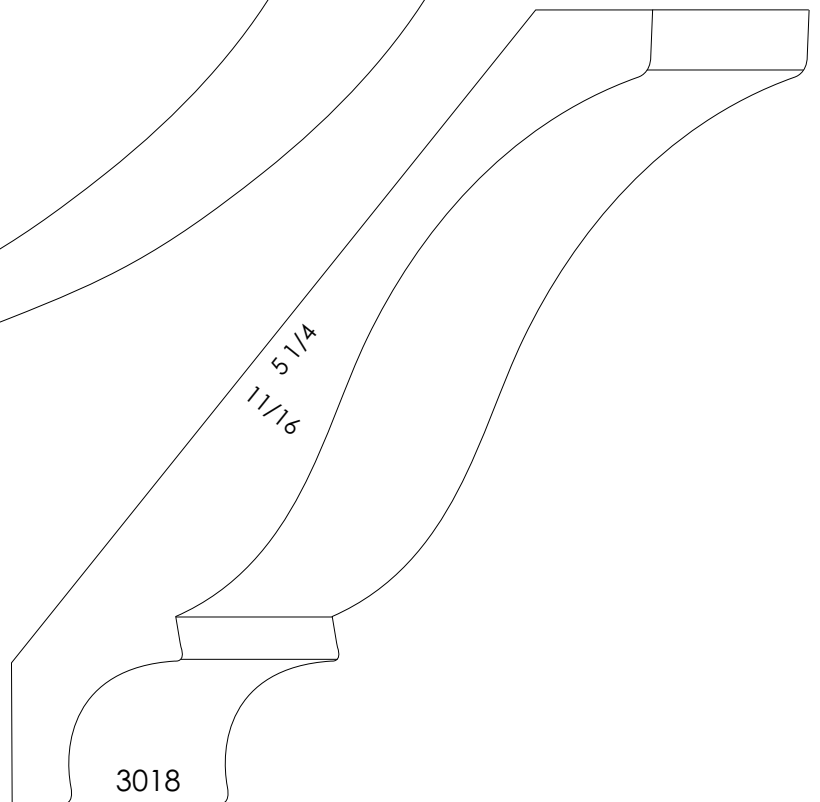
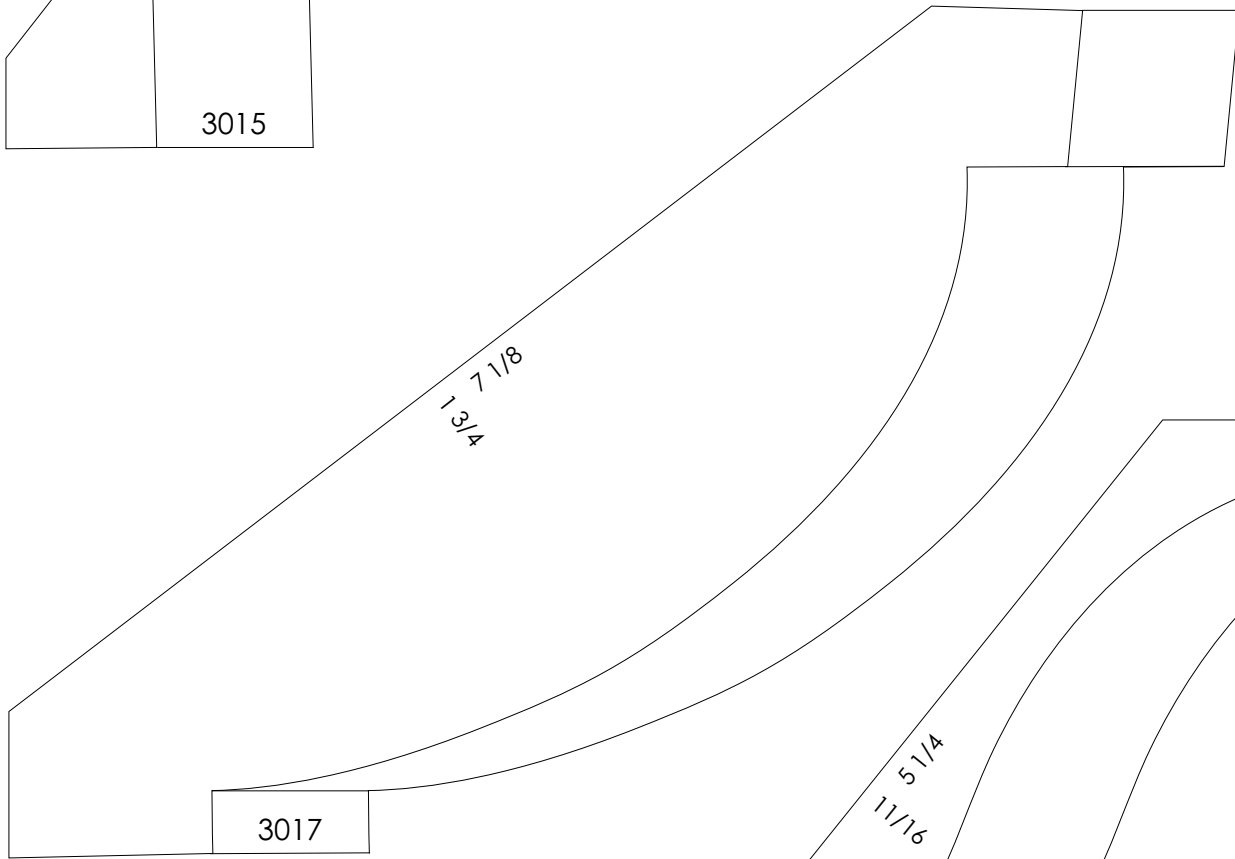
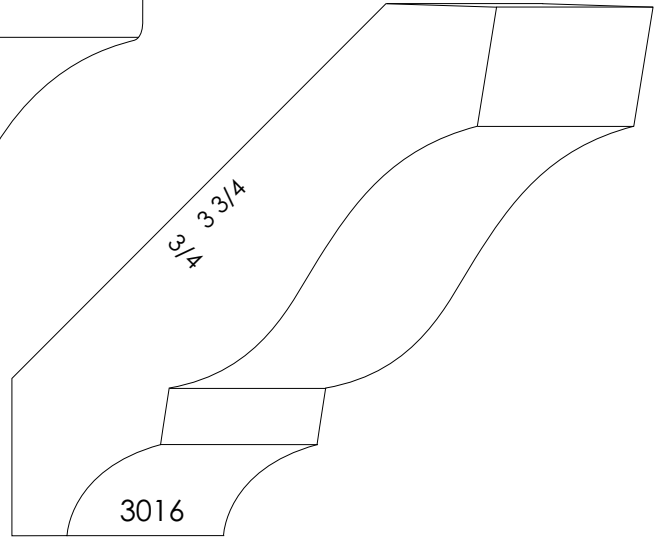
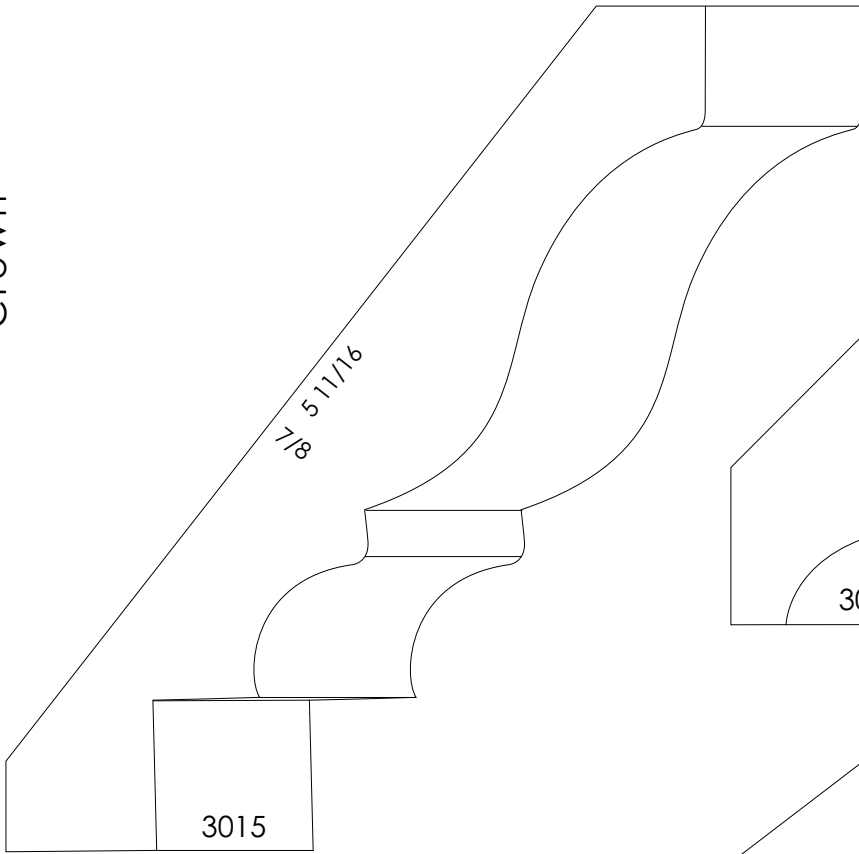

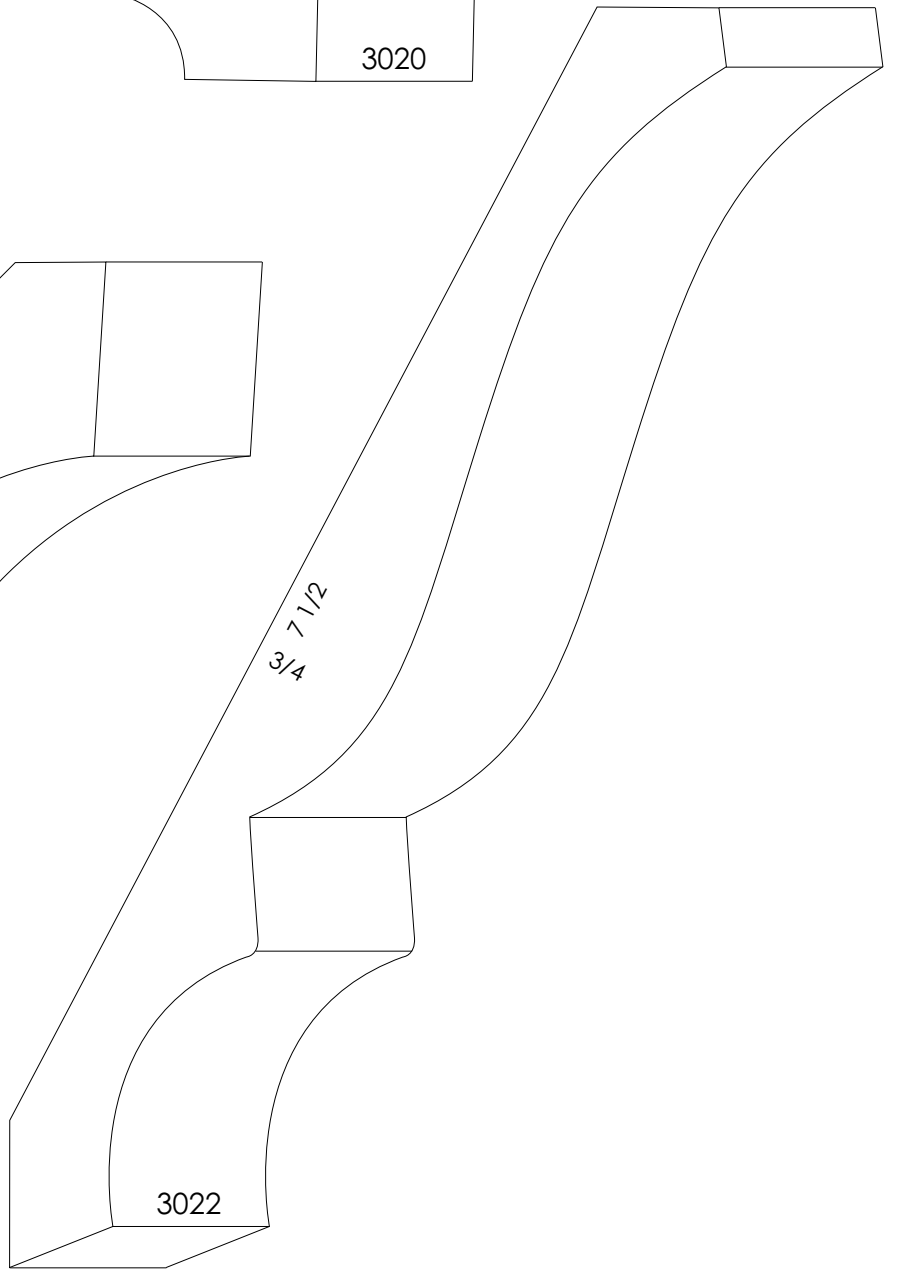
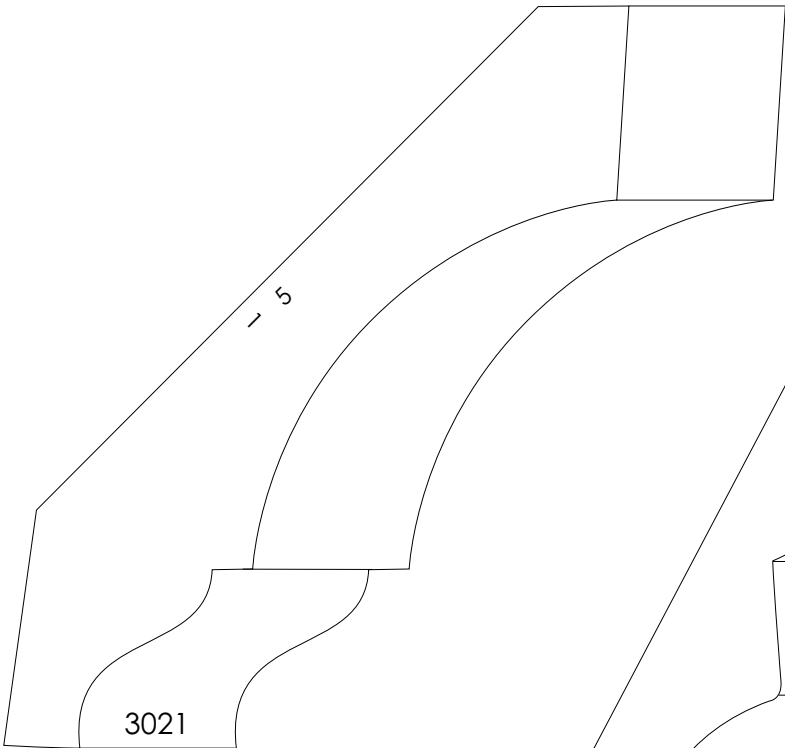
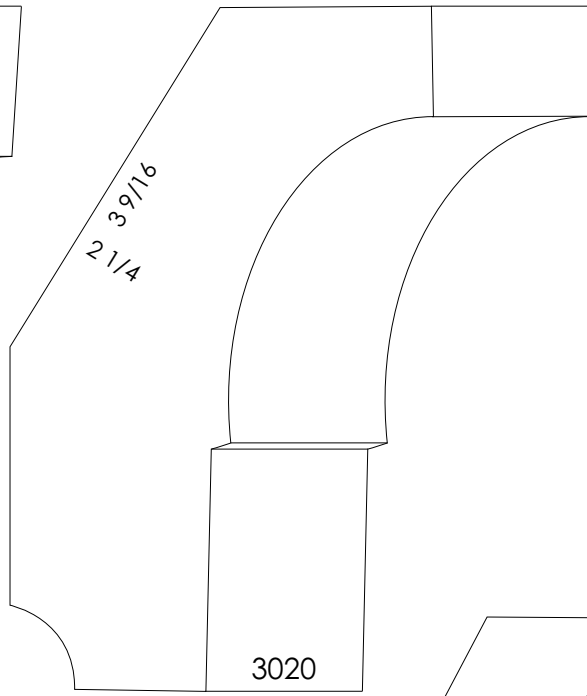
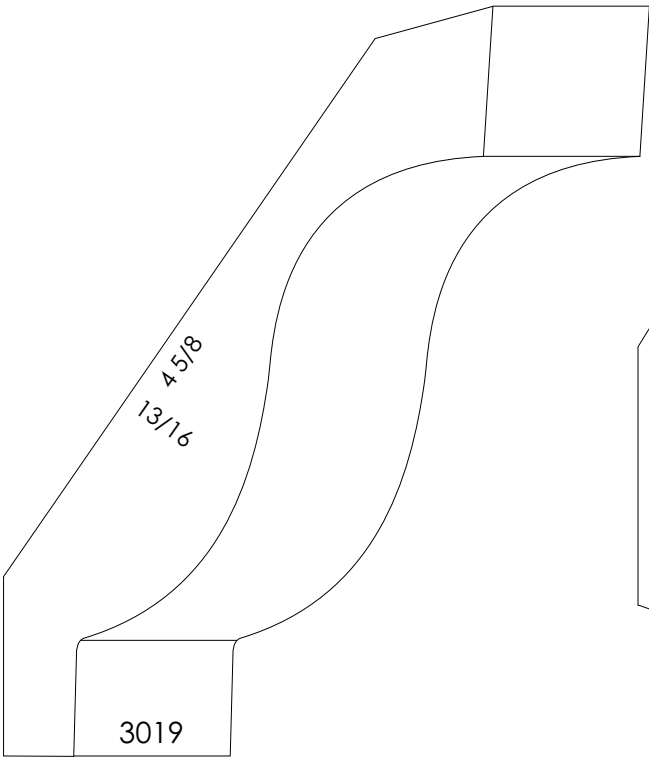

Crown

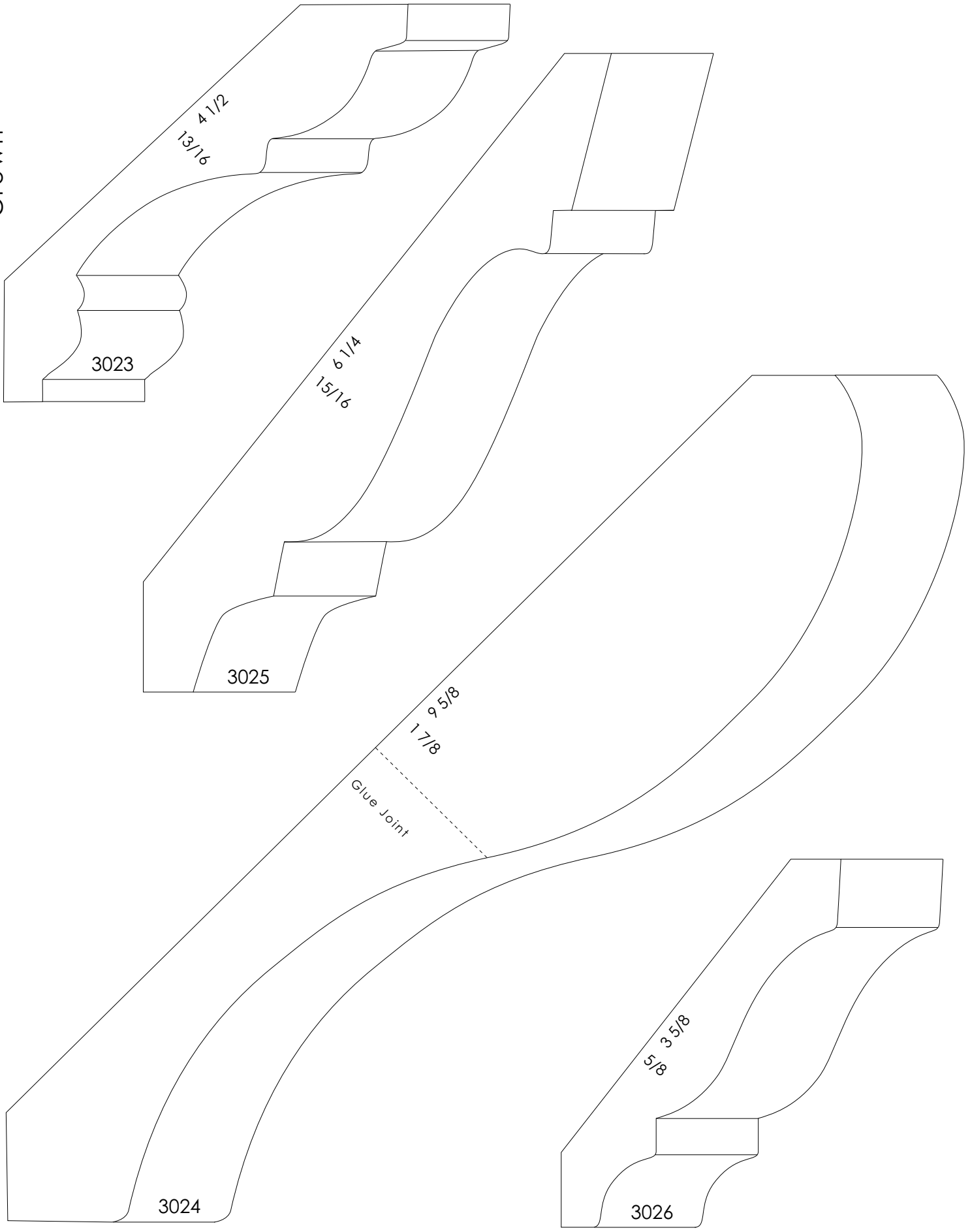

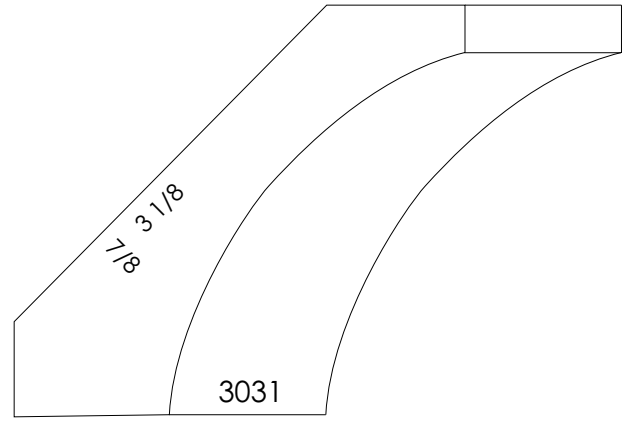
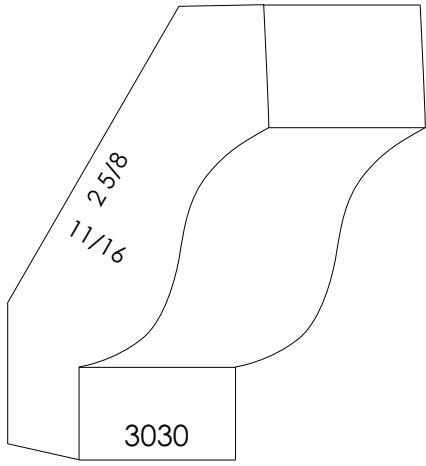
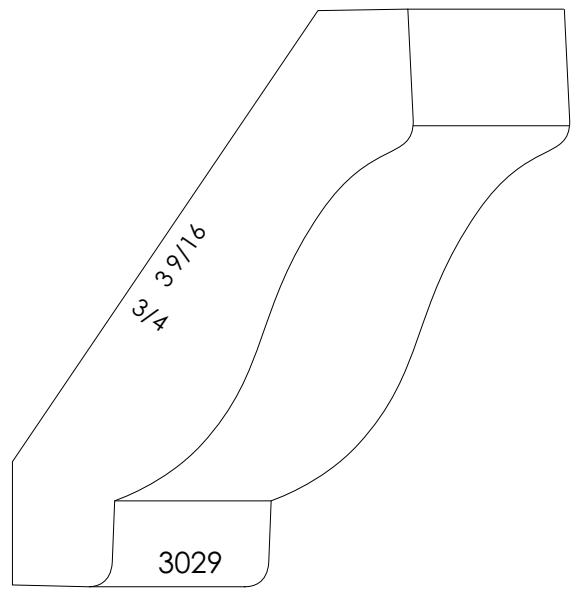
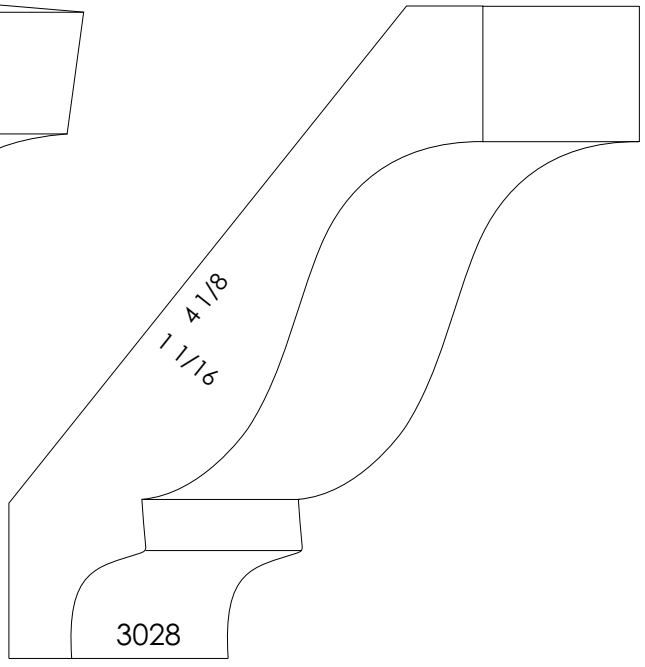
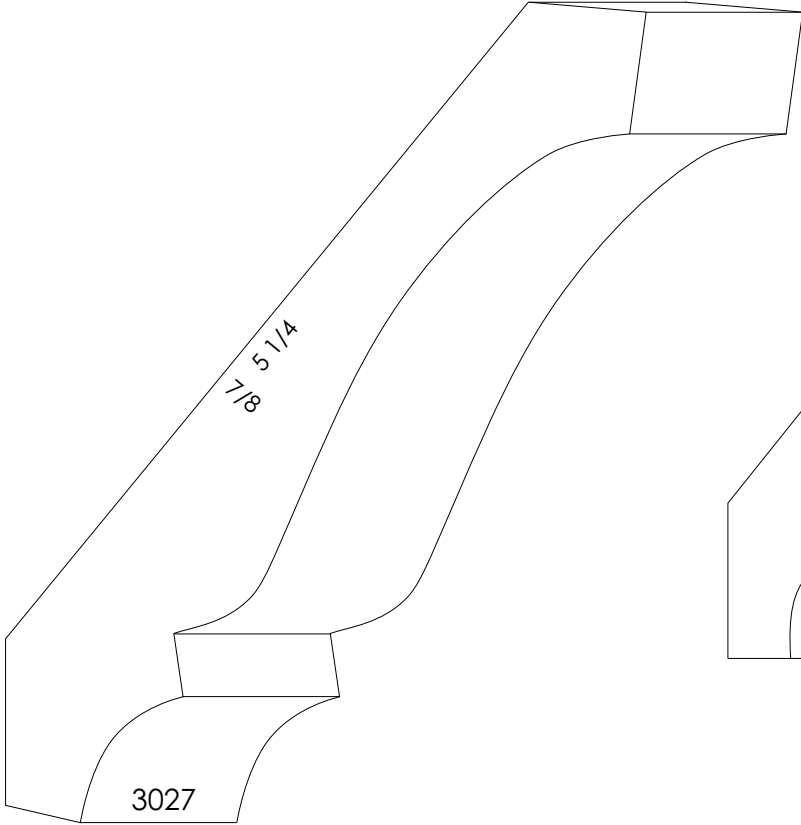

Crown

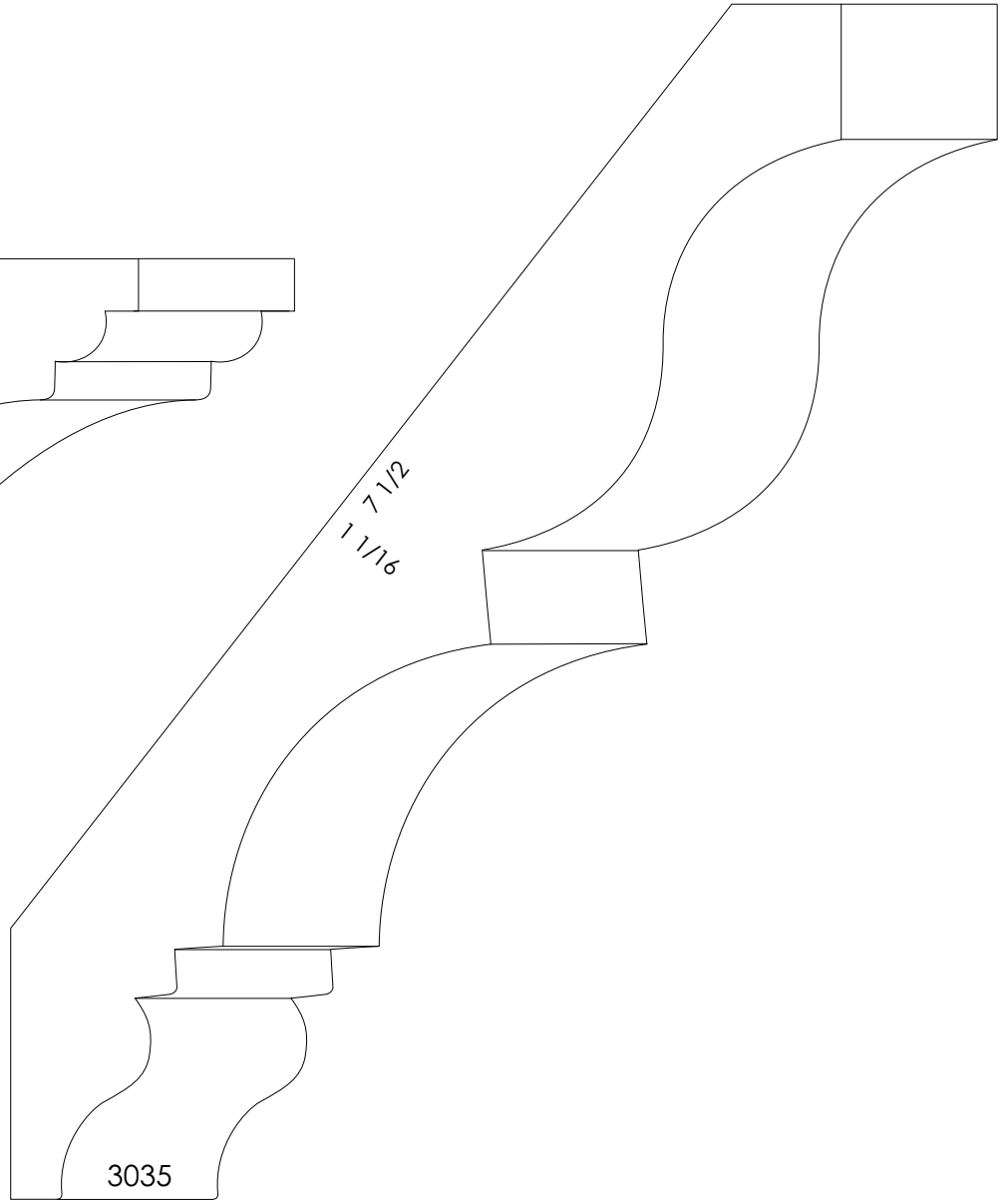
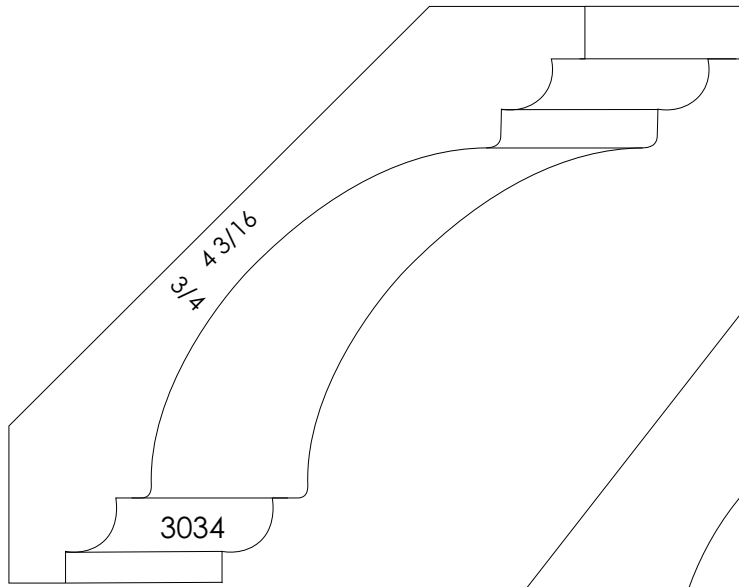
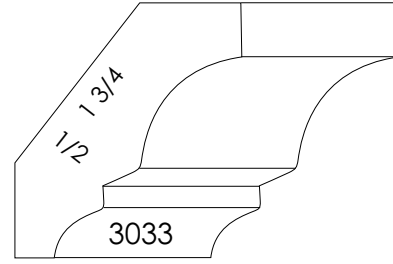
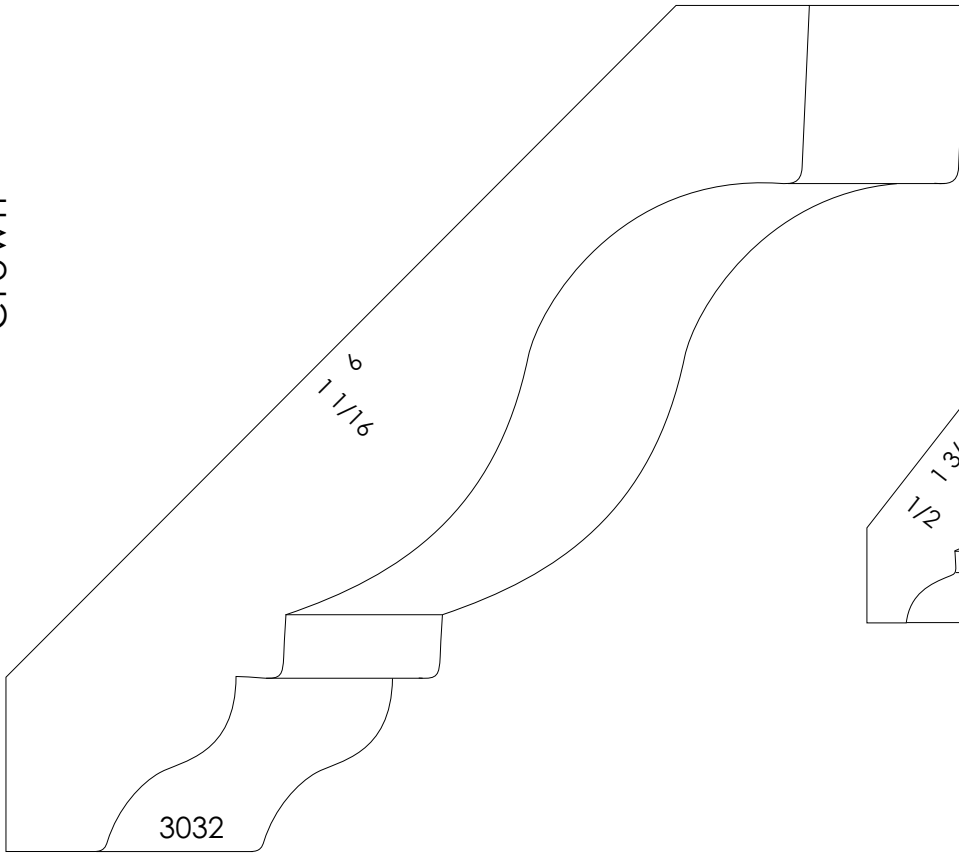

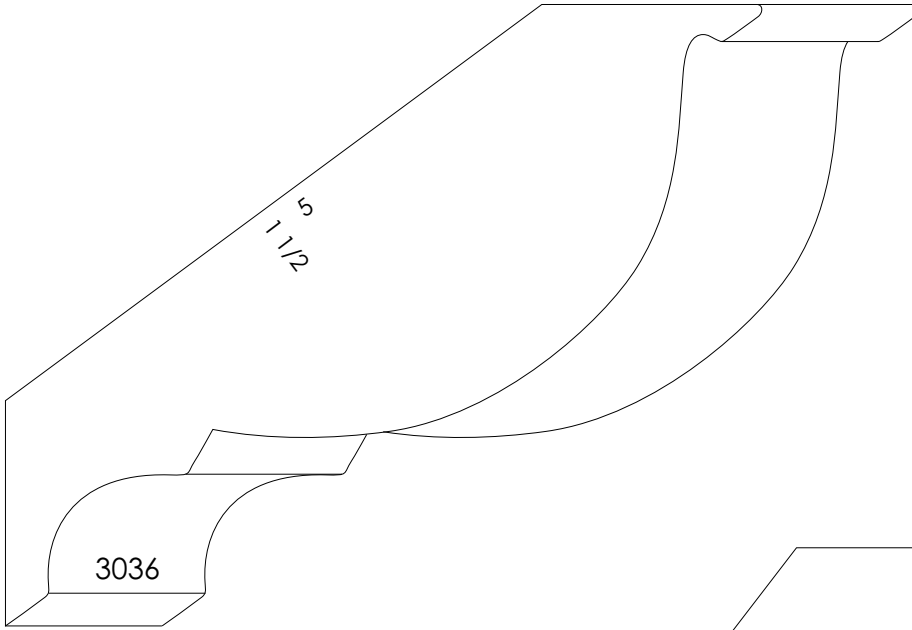

3036

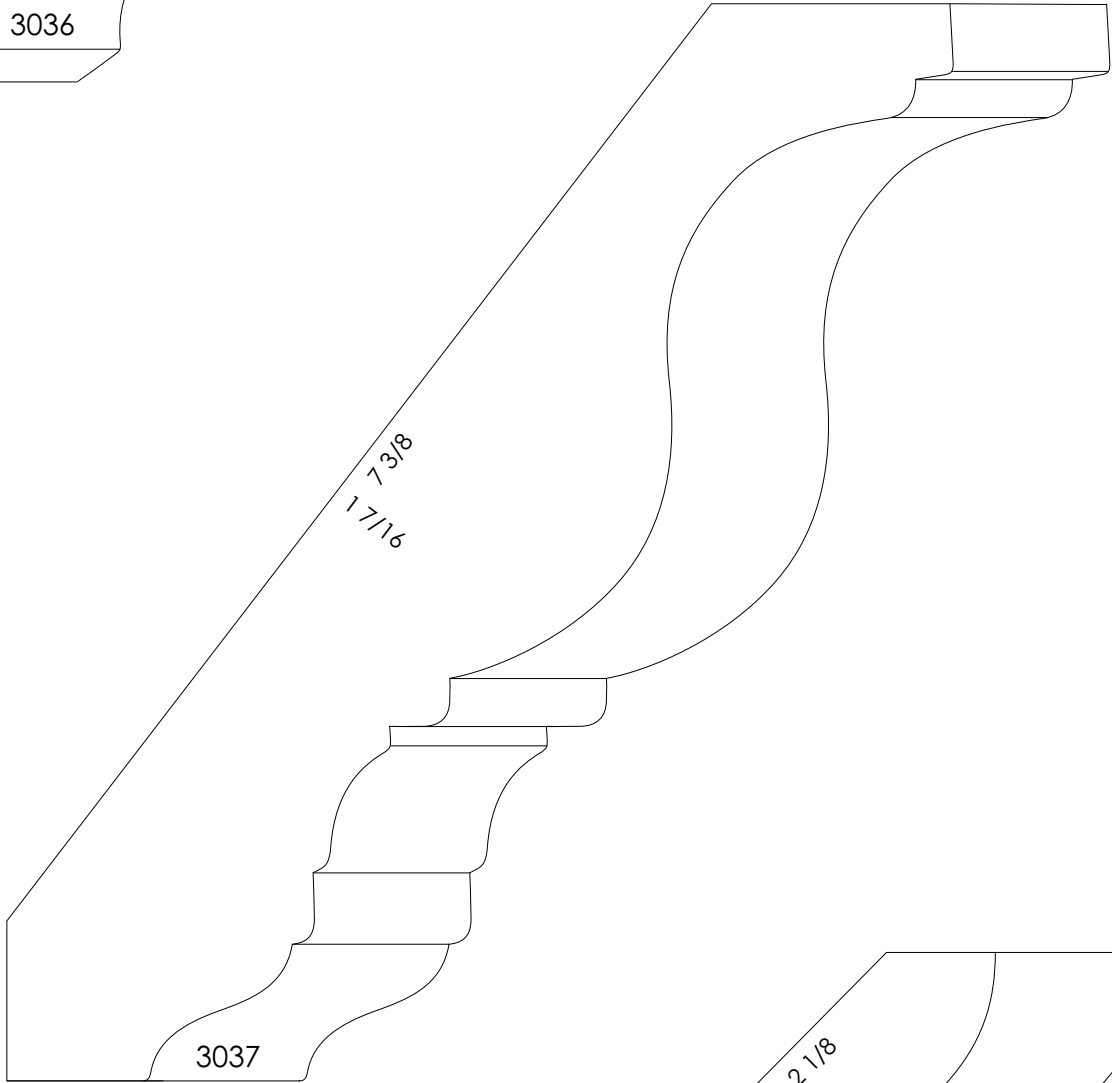

7 3/8
1 7/16

3037

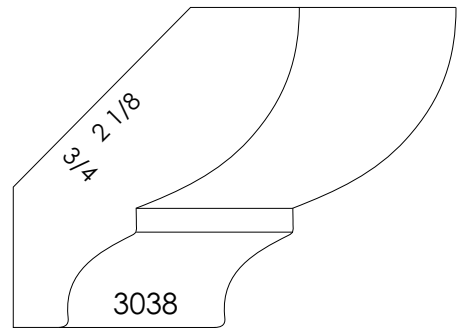

3/4 2 1/8

3038

Crown

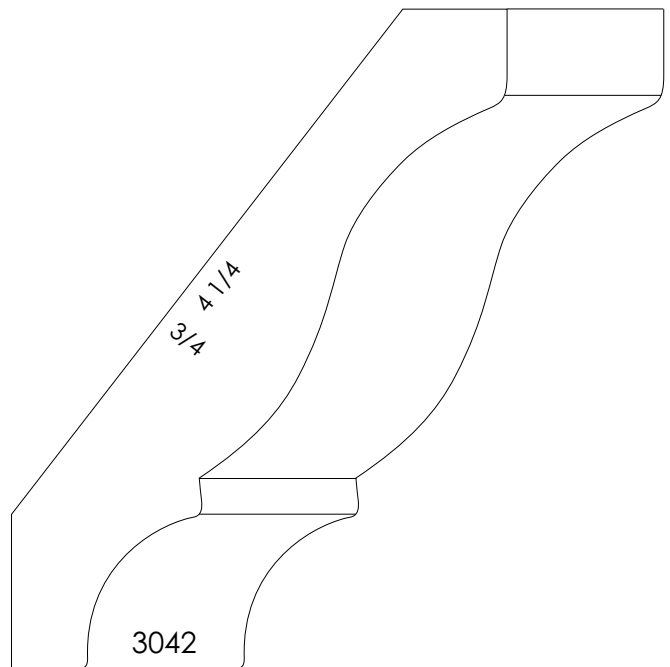
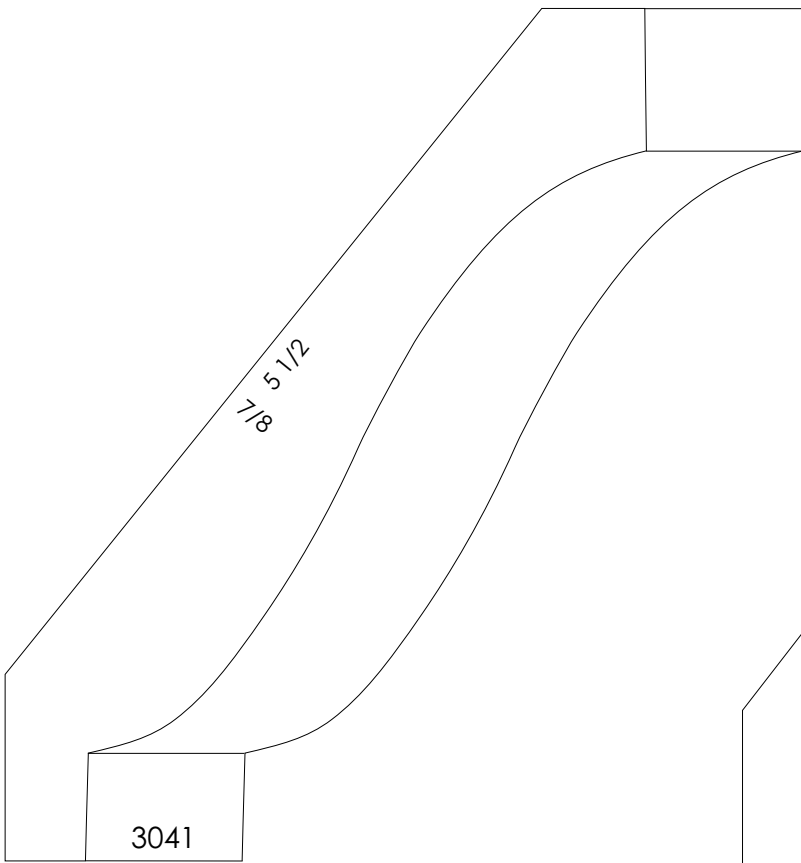
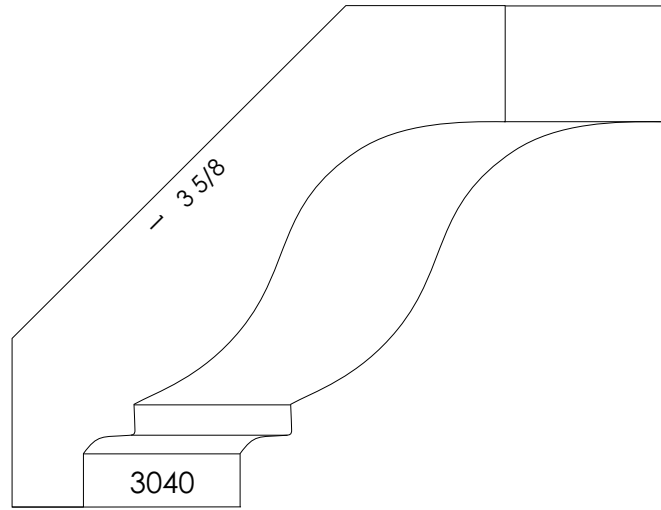
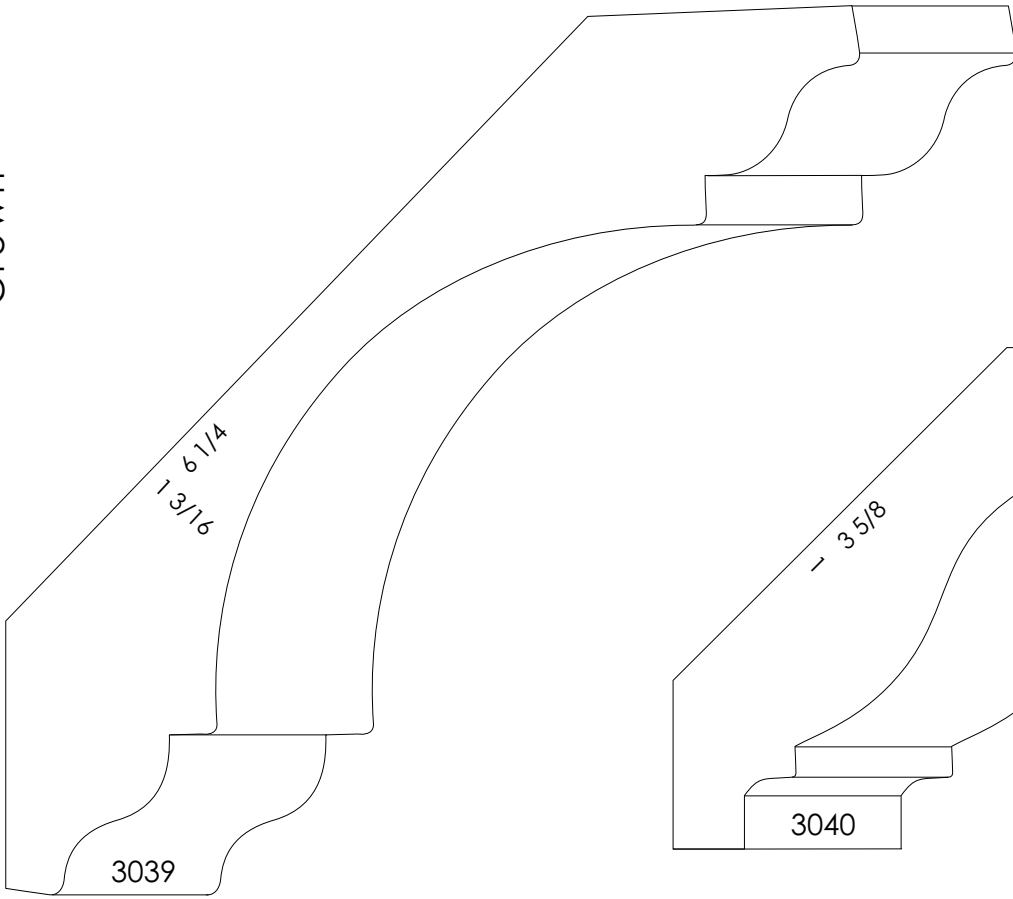

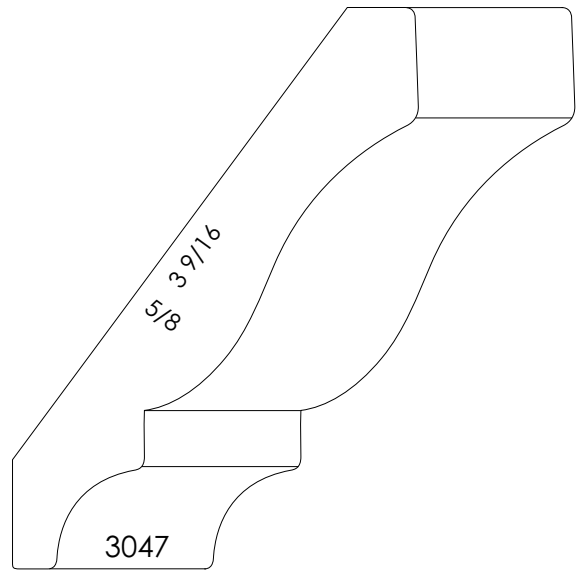
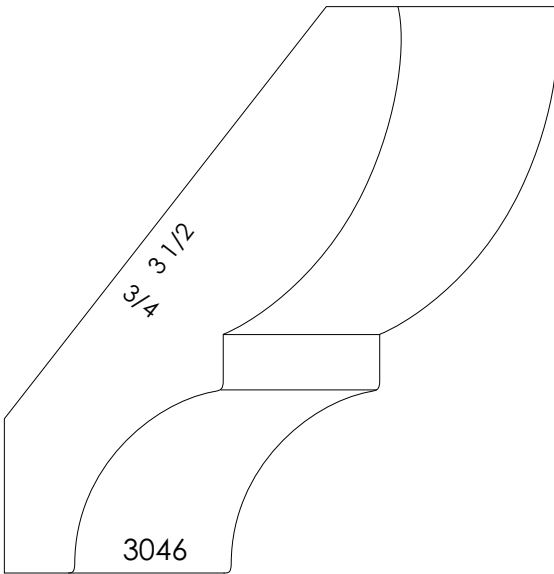
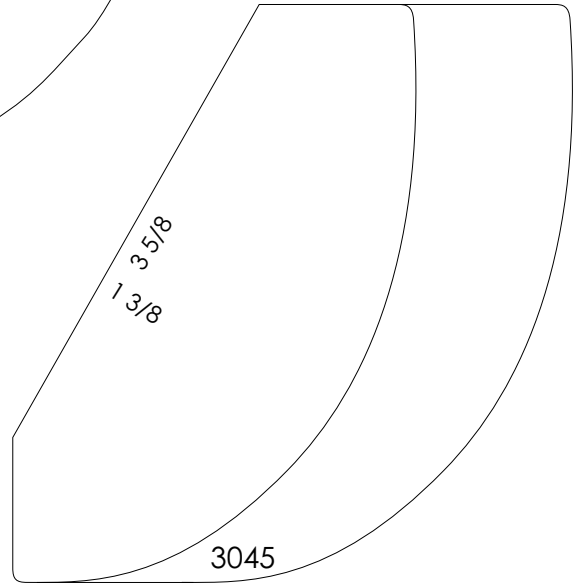
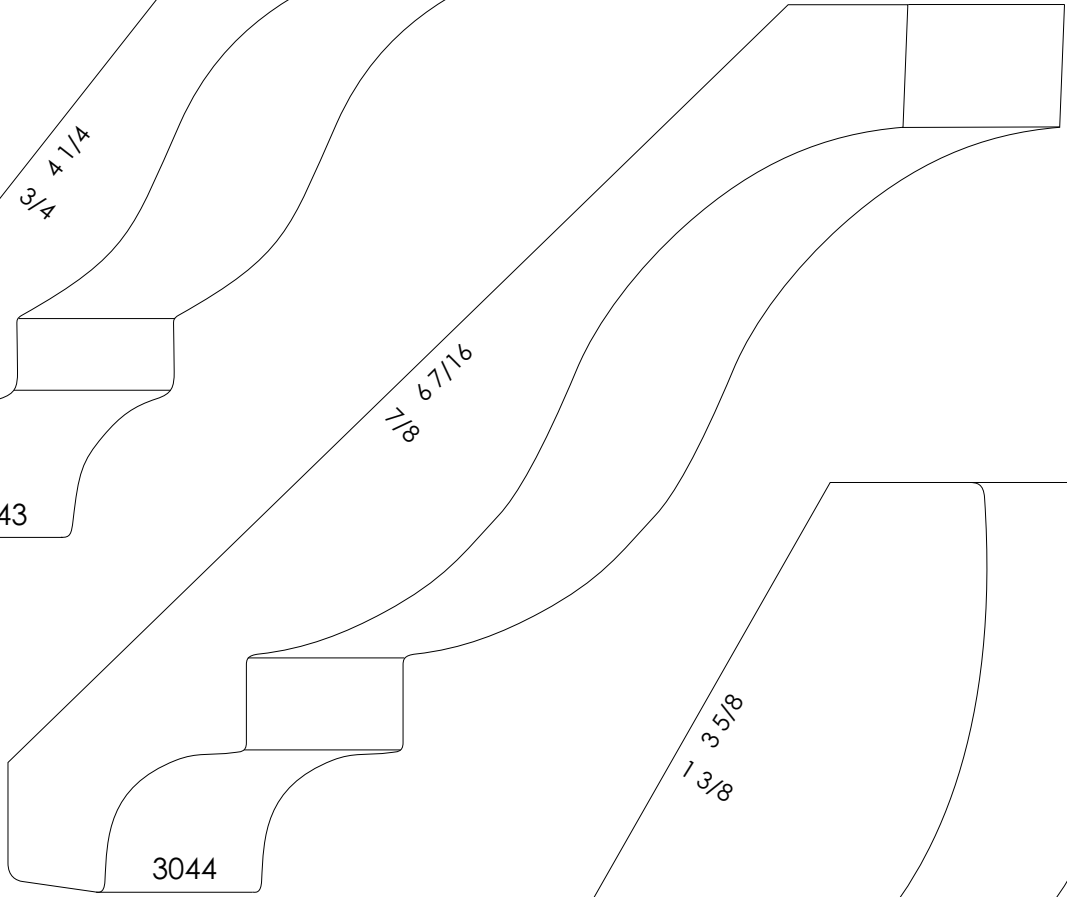
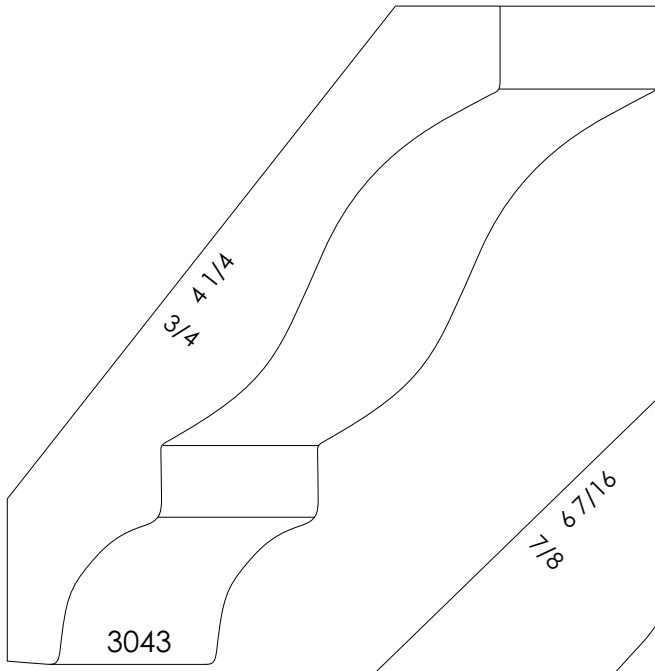

Crown

Crown

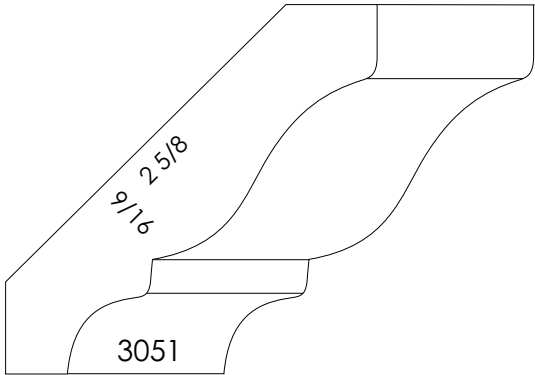
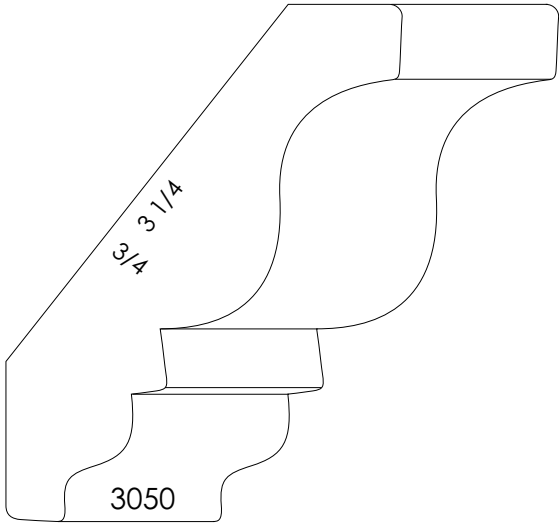
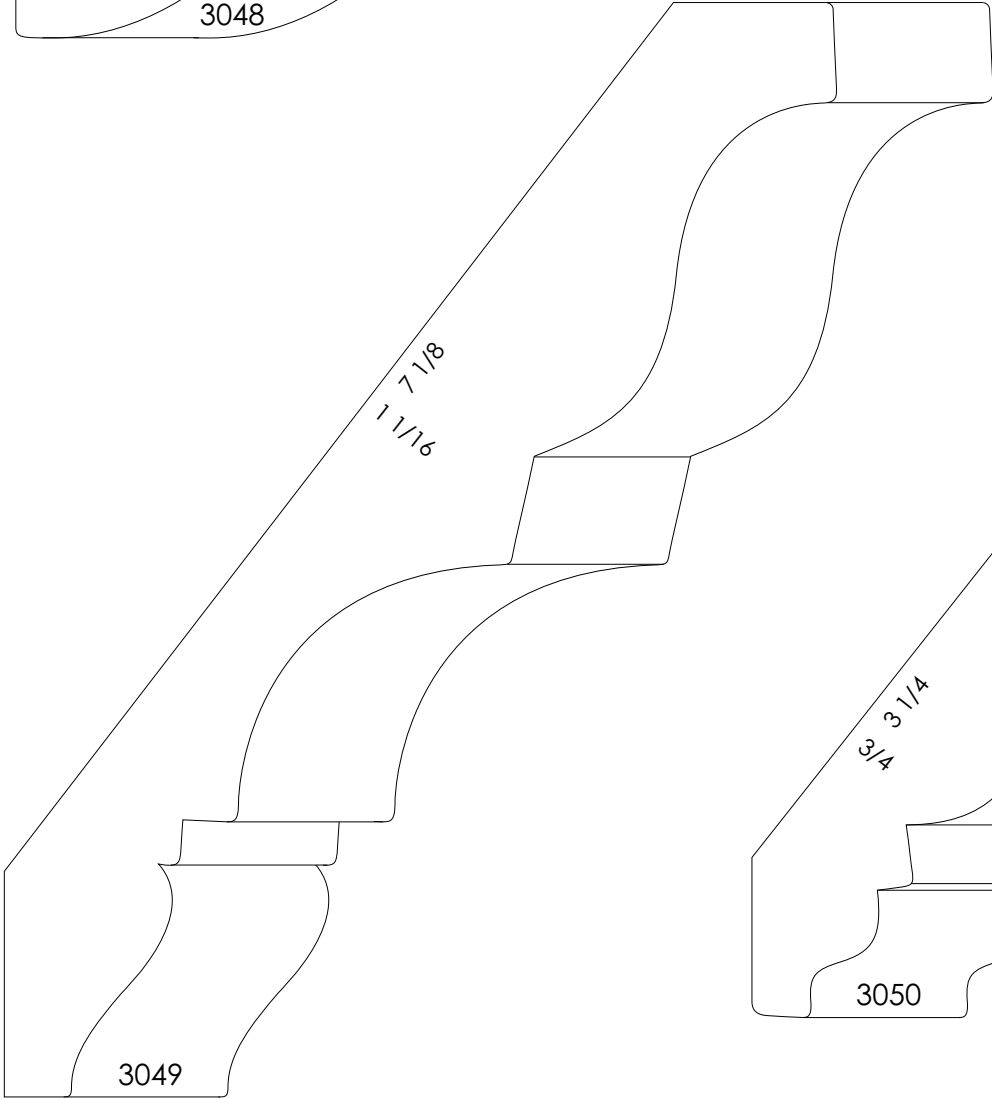
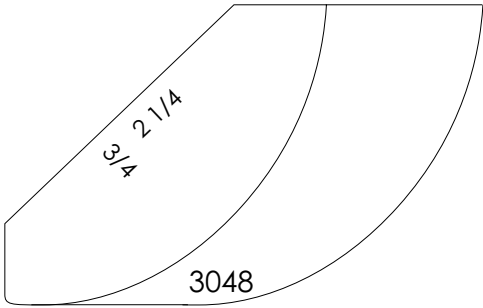

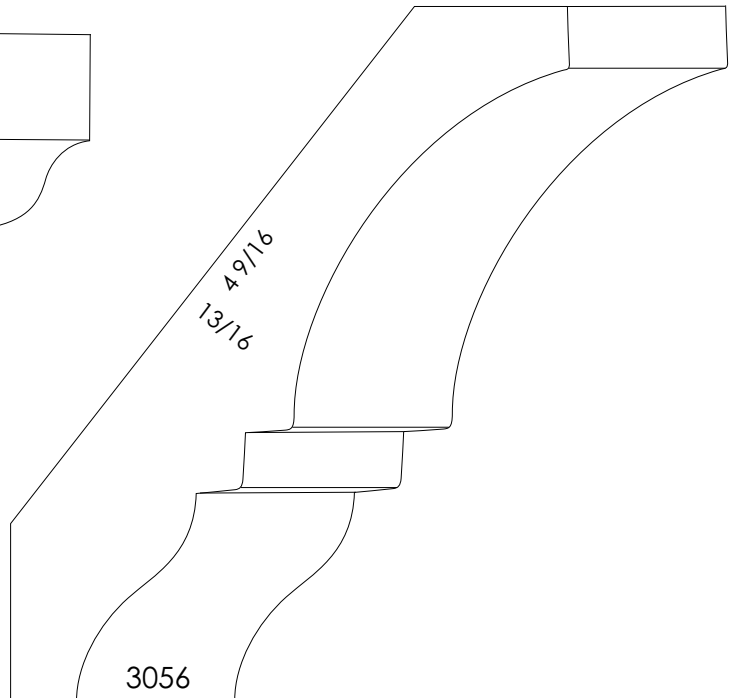
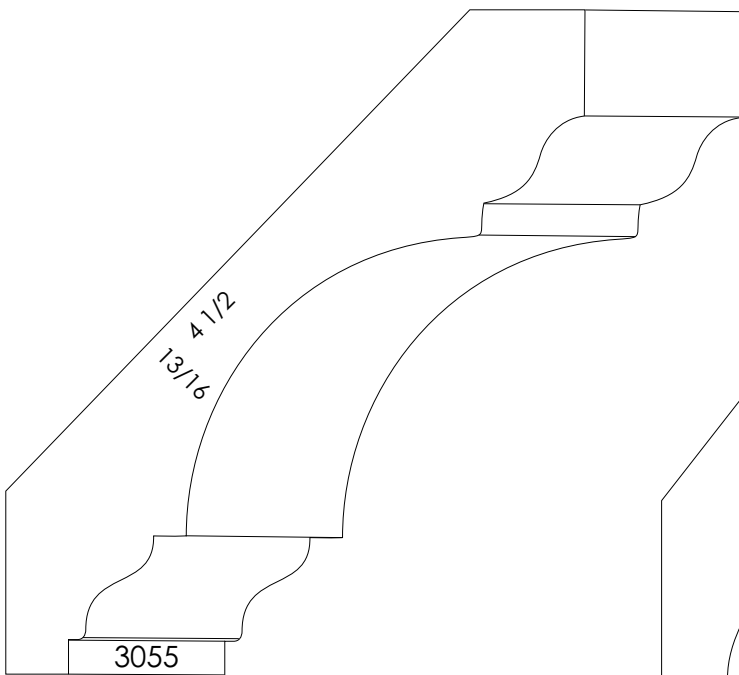
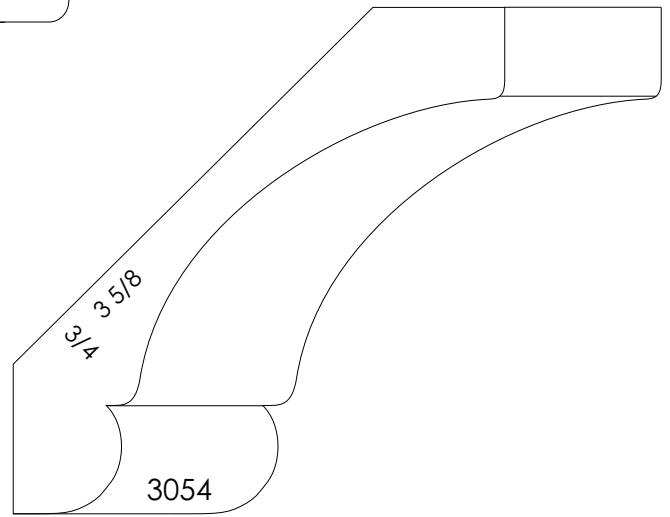
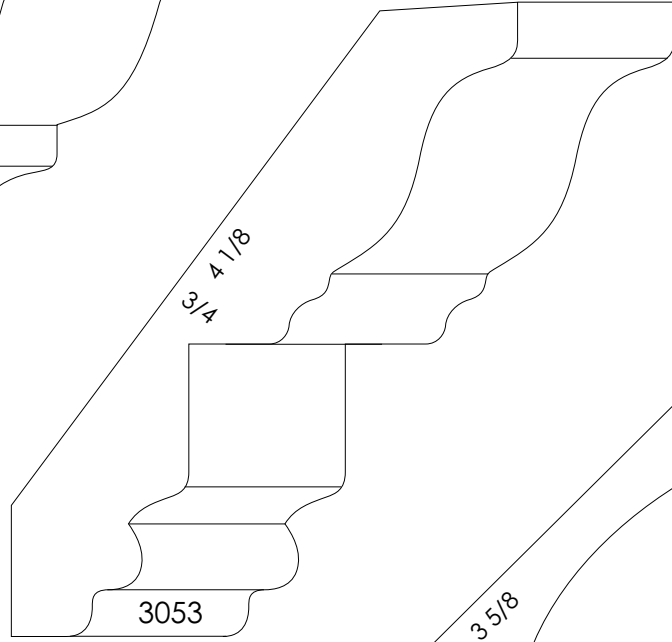
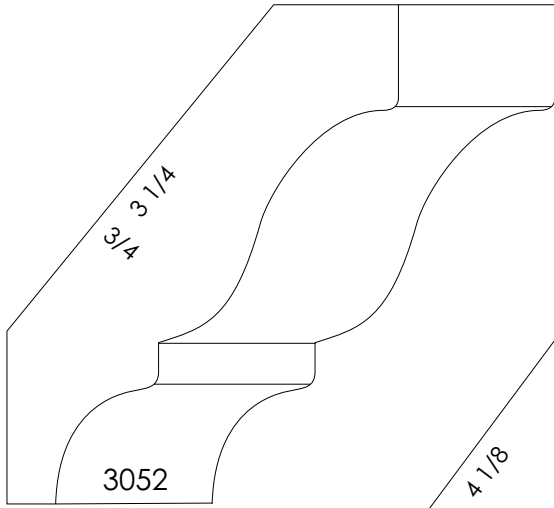

Crown

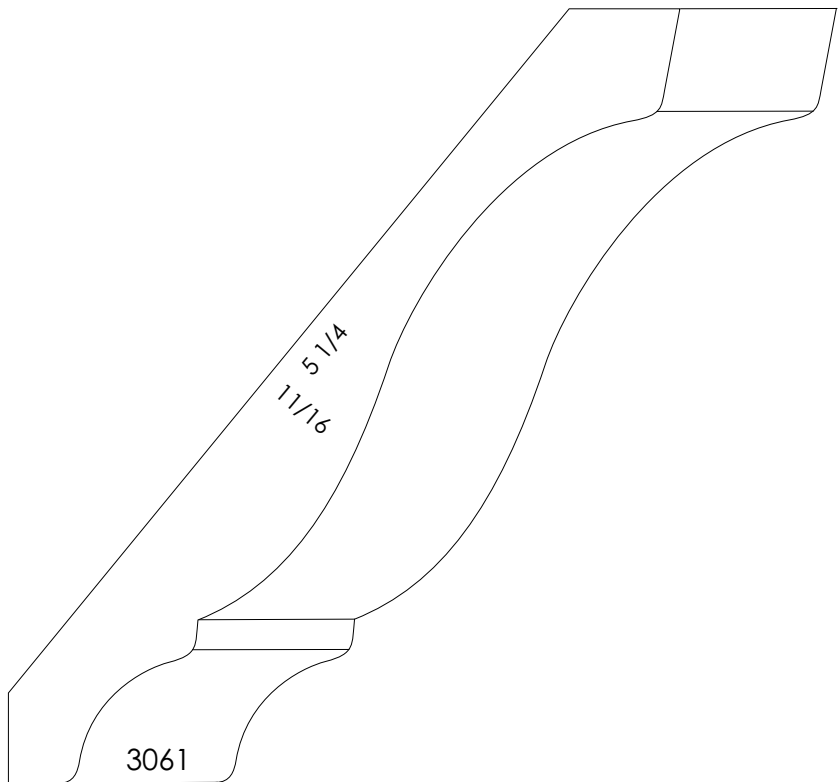
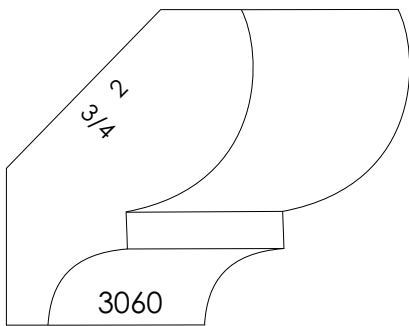
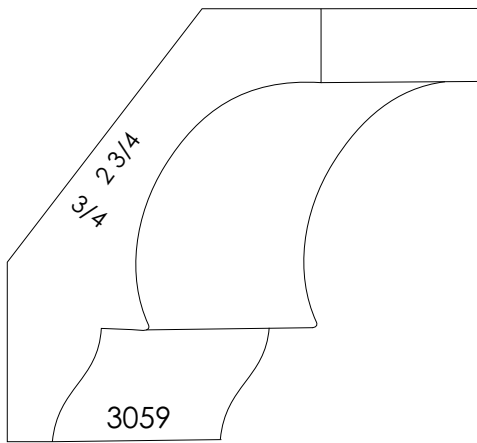
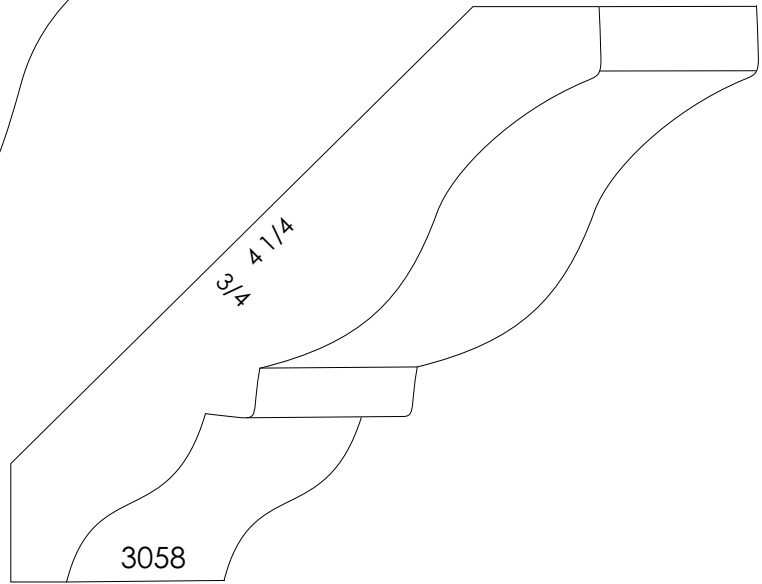
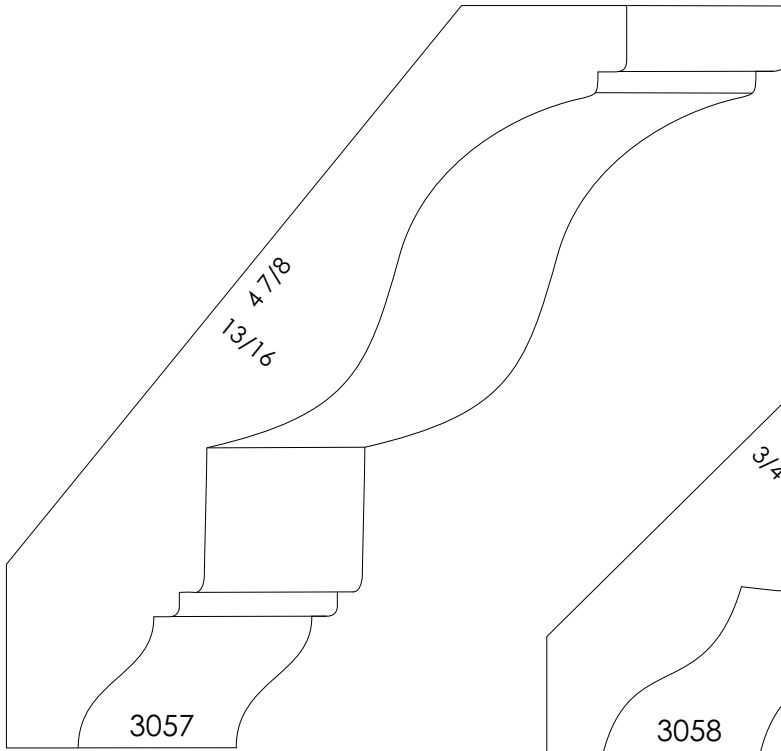

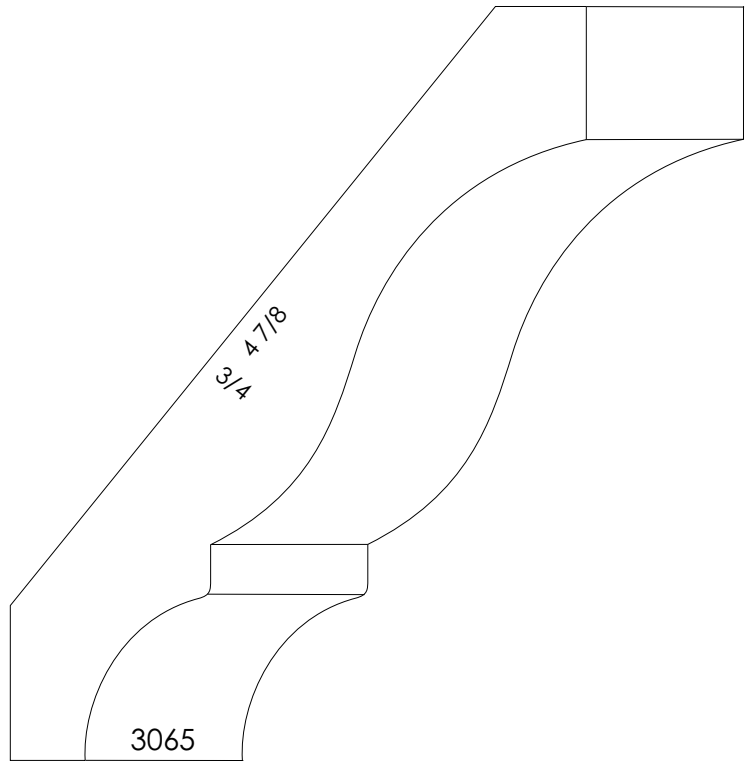
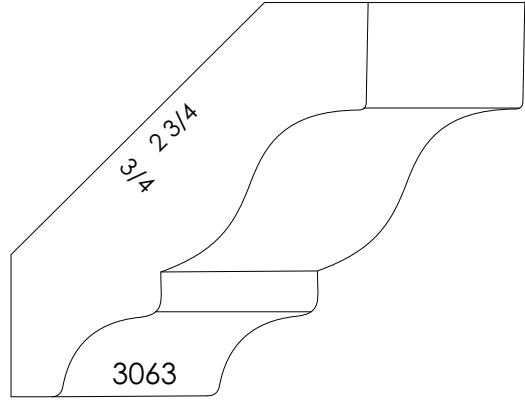

Crown

Crown

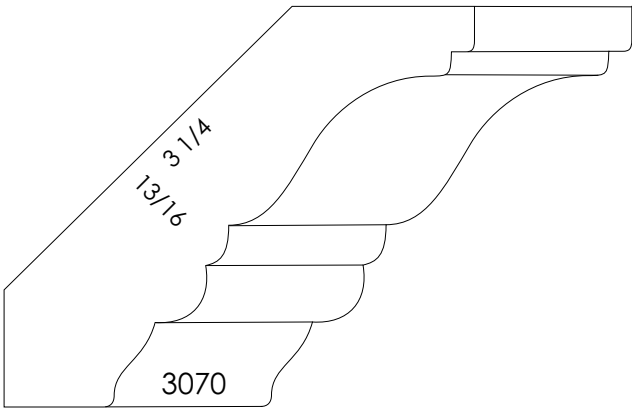
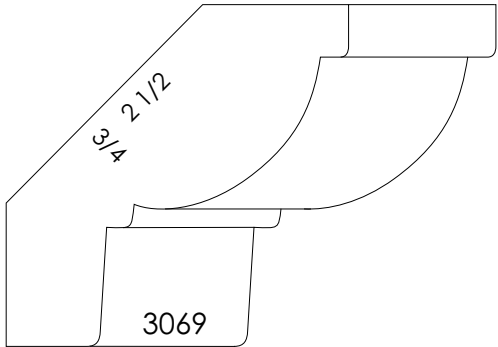
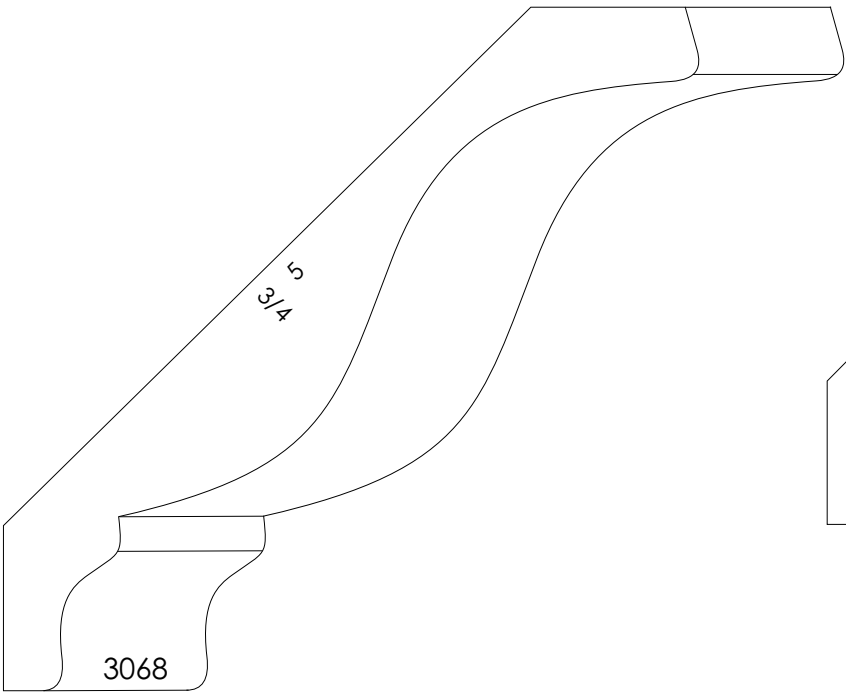
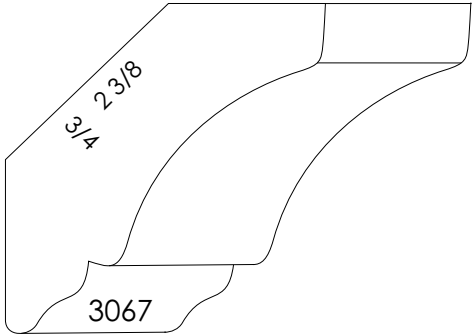
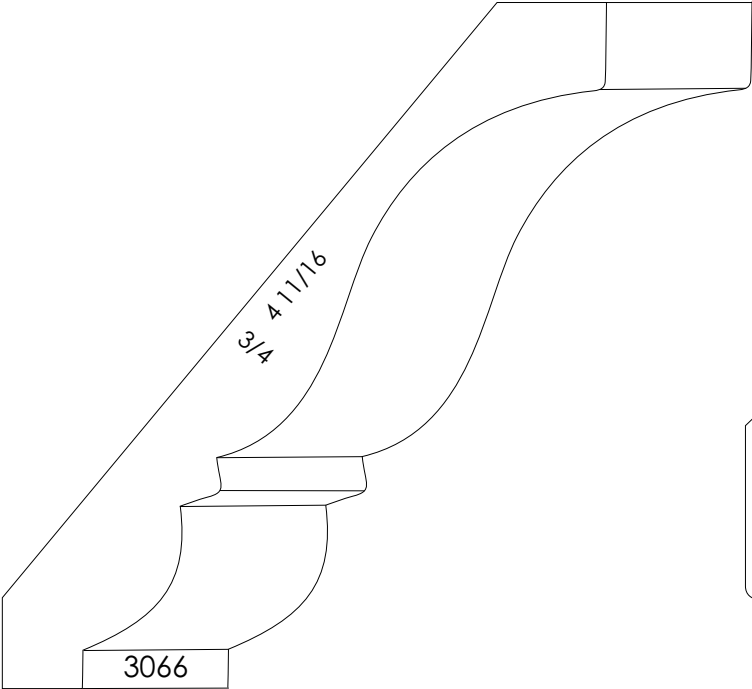

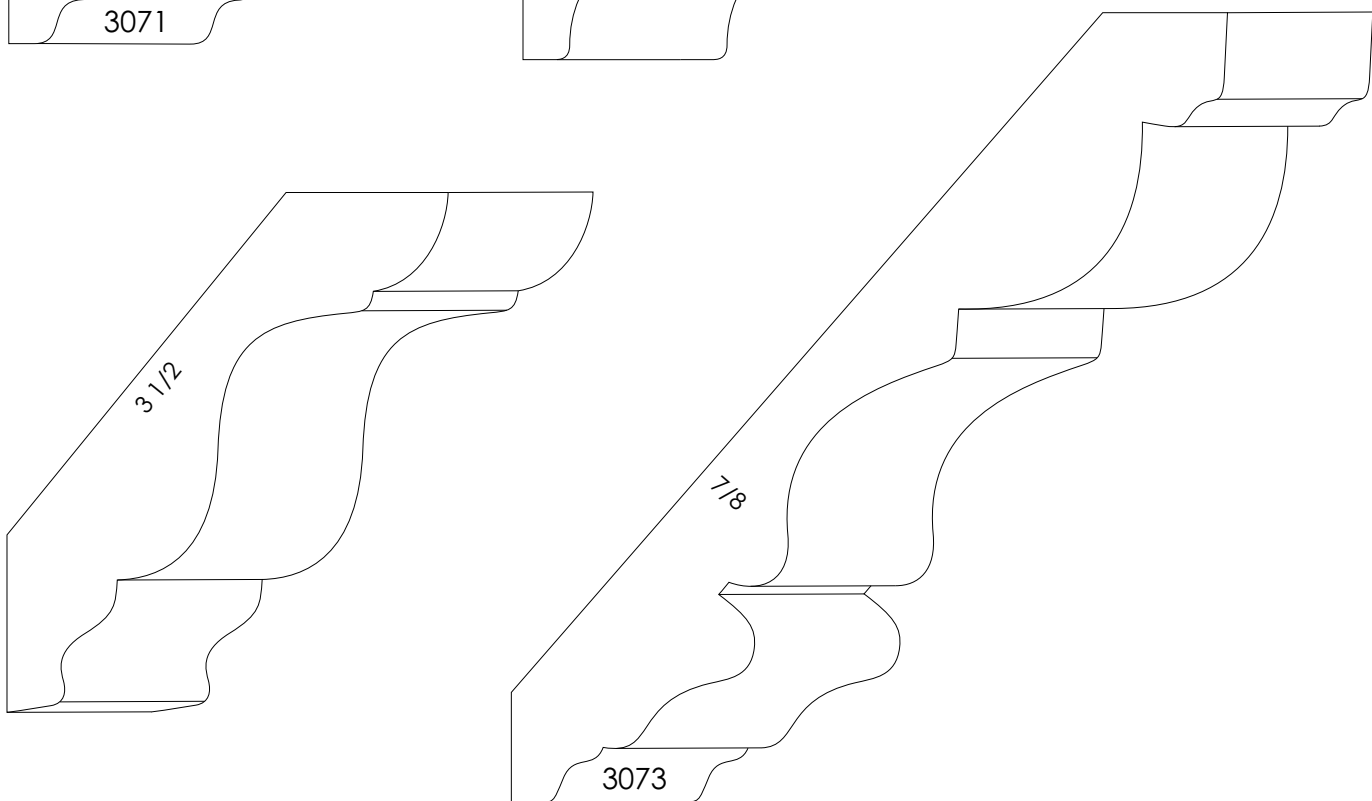
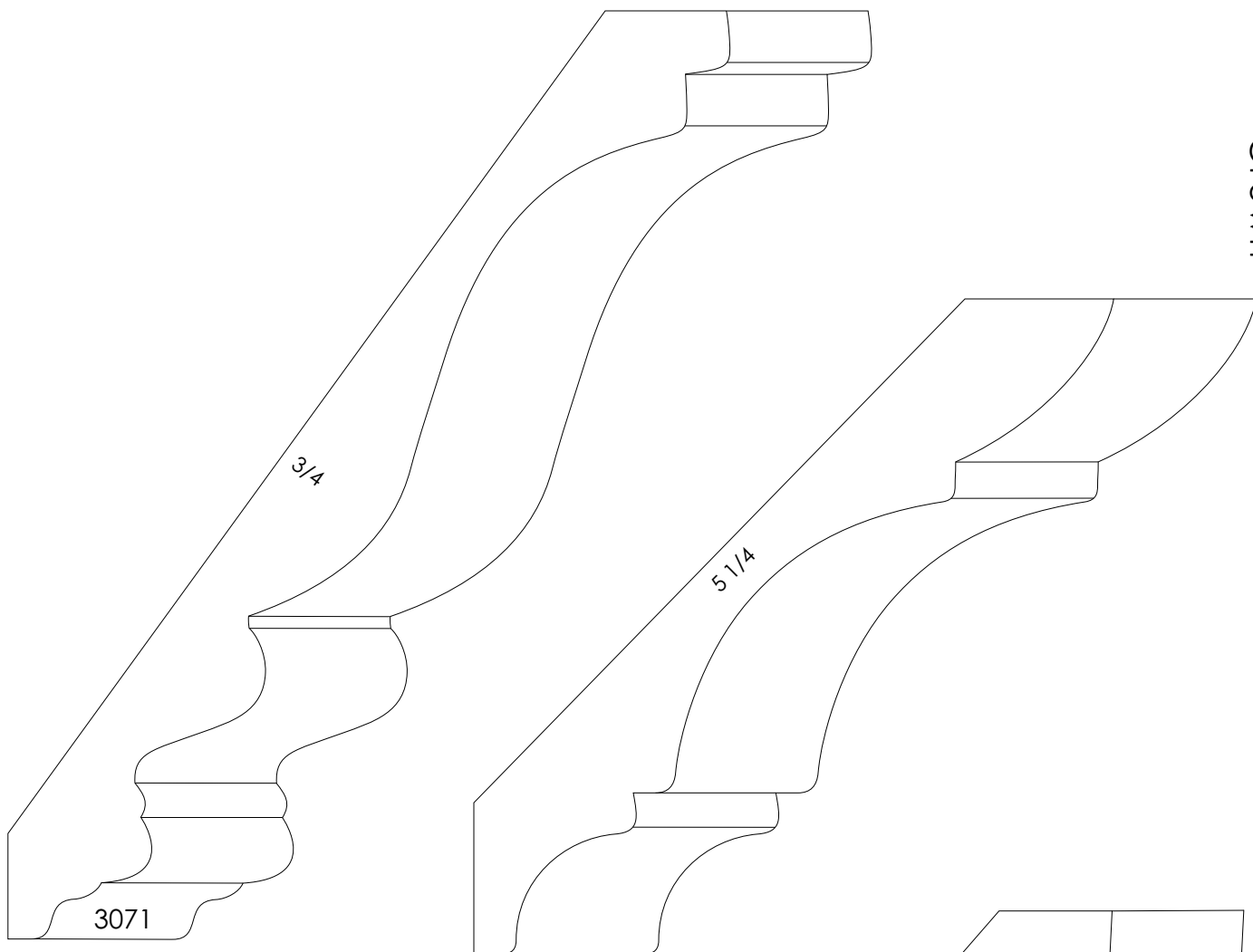

Cove

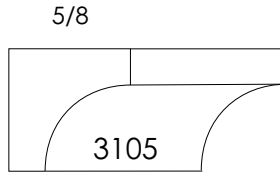
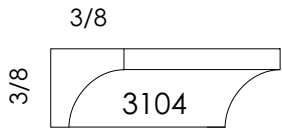
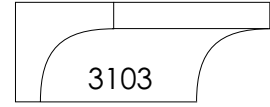
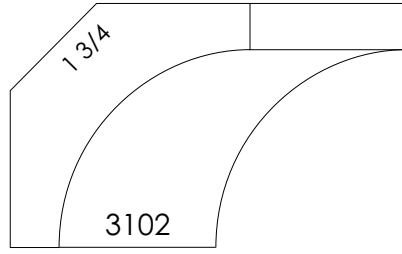
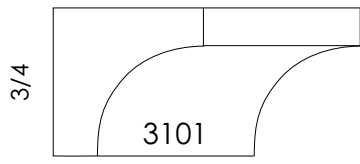

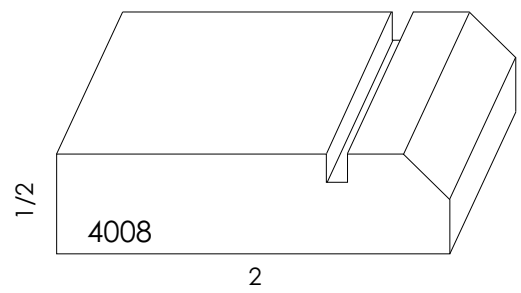
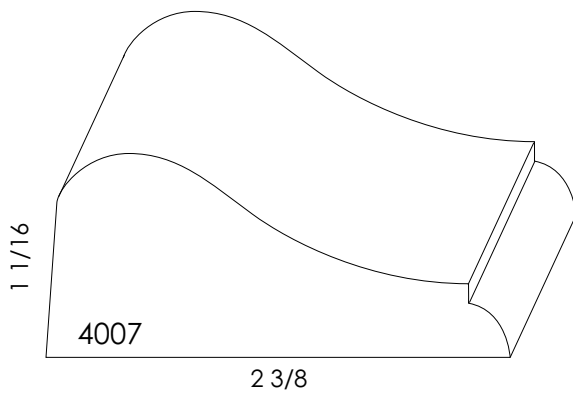
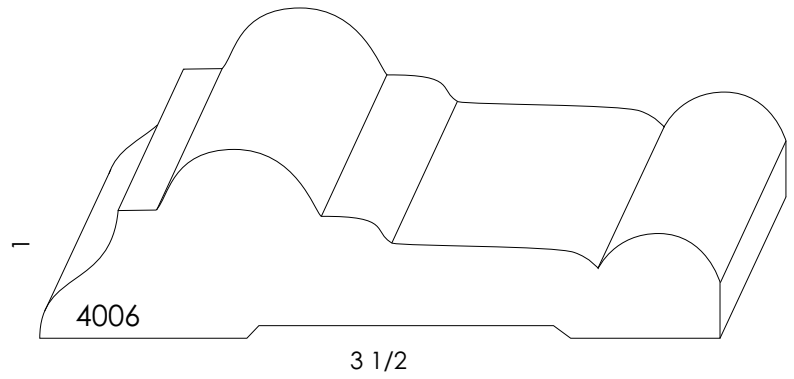
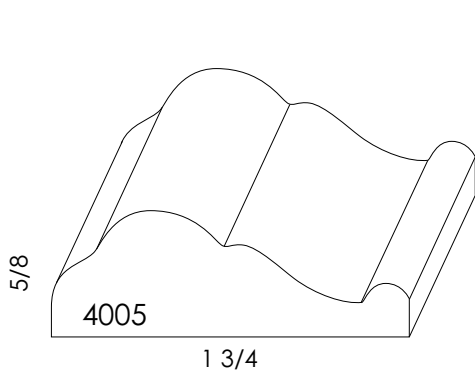
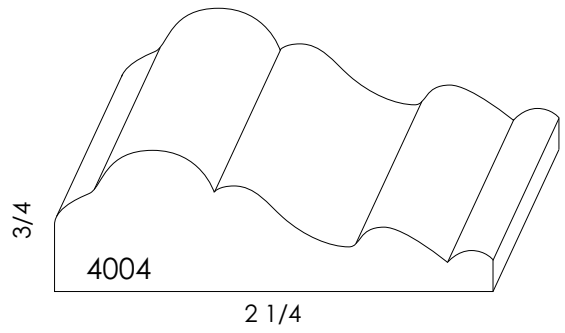
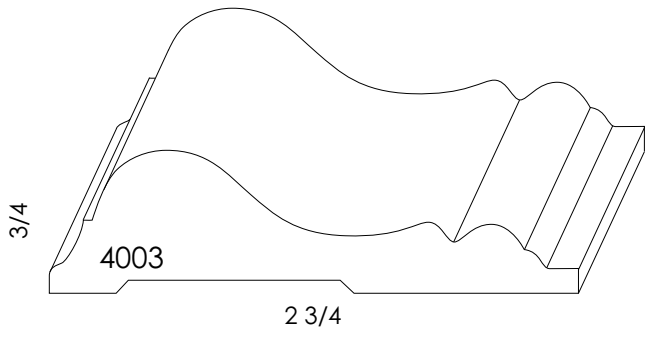
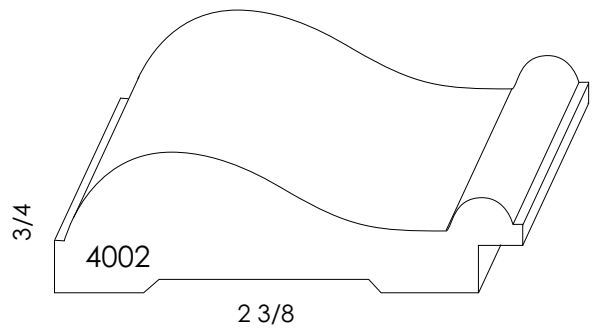
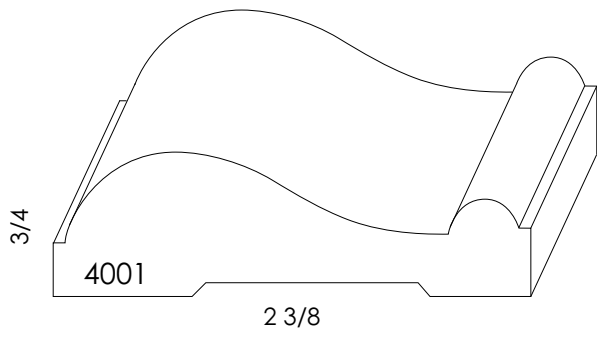

Chair Rail

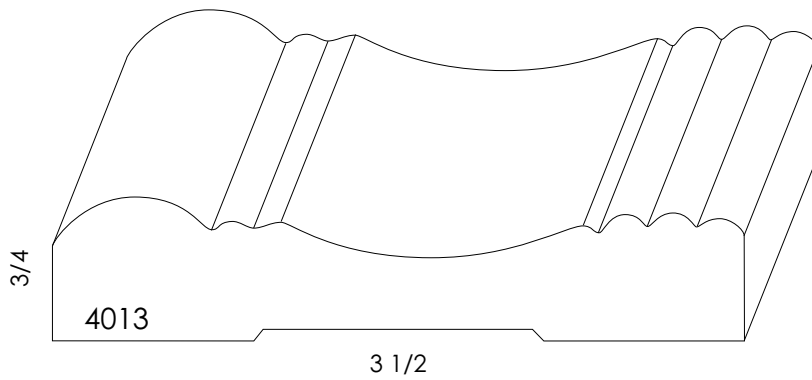
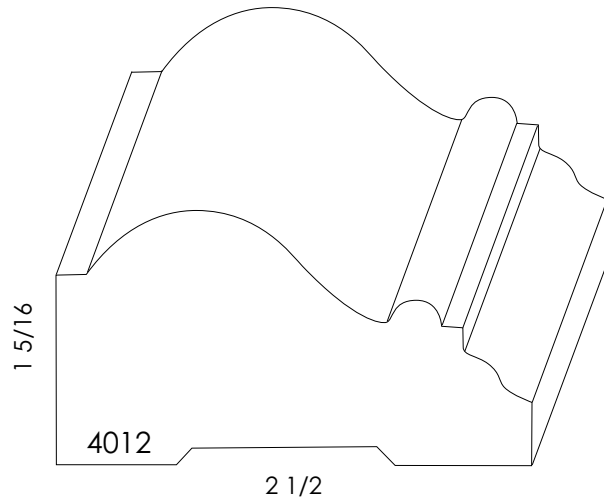
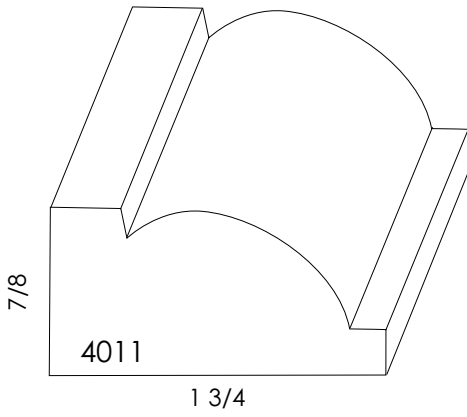
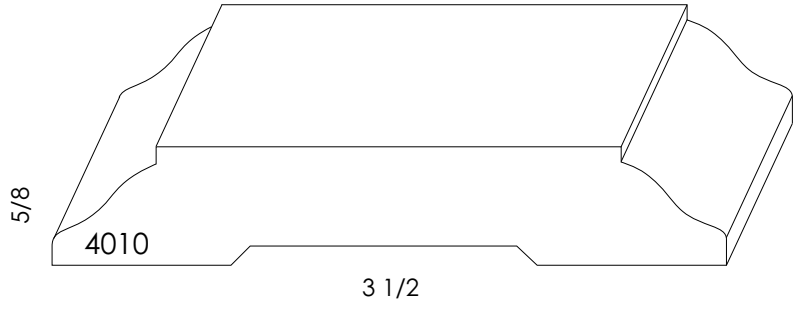
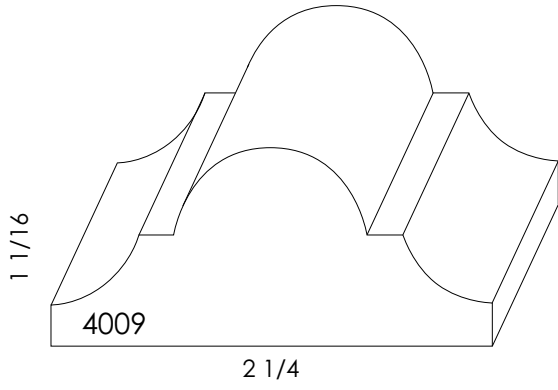

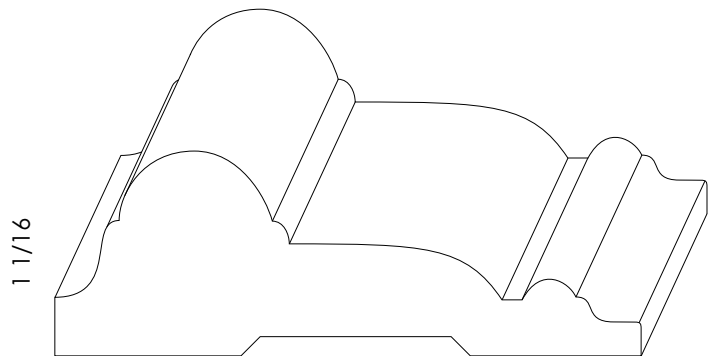
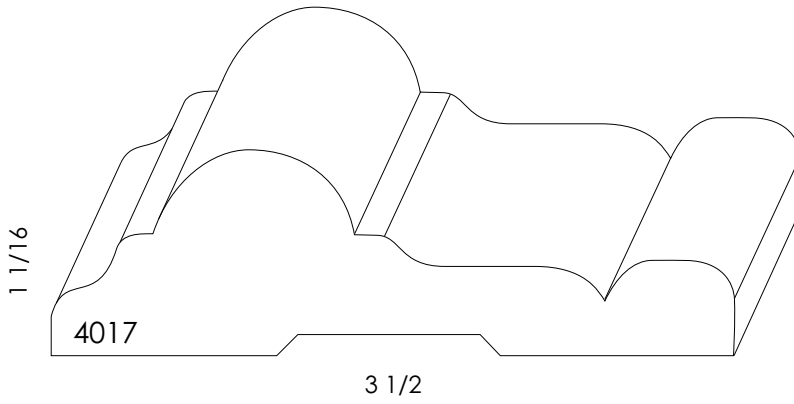
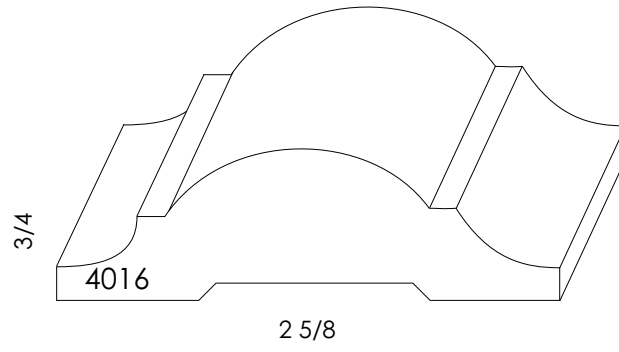
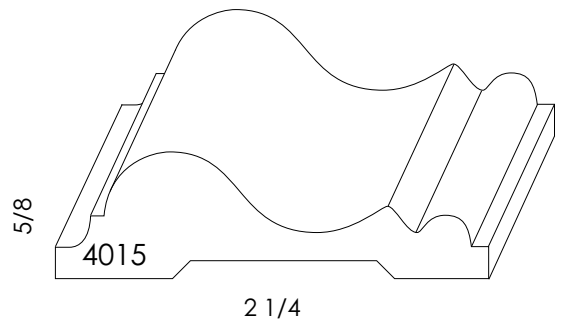
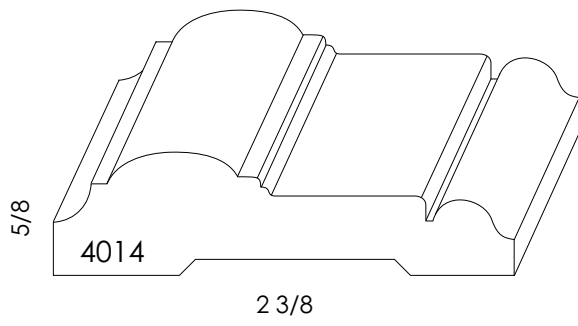

Small Mold

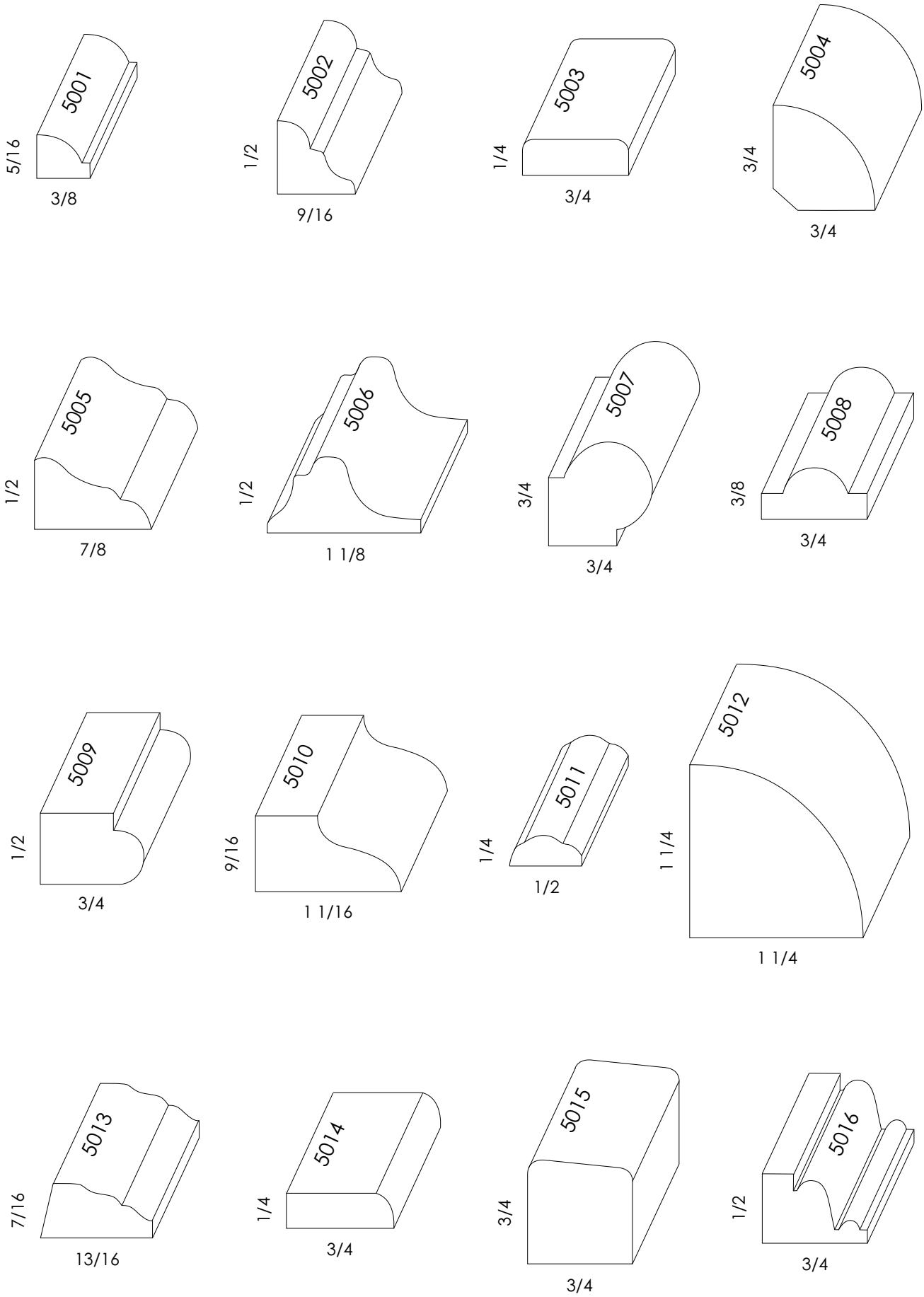

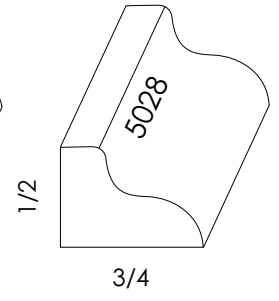
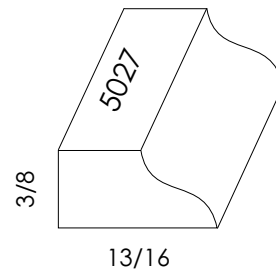
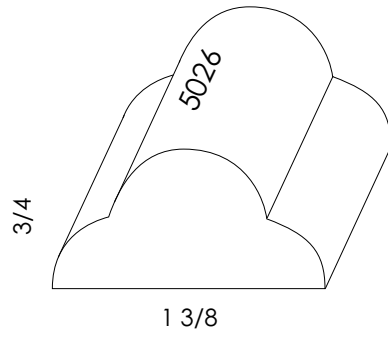
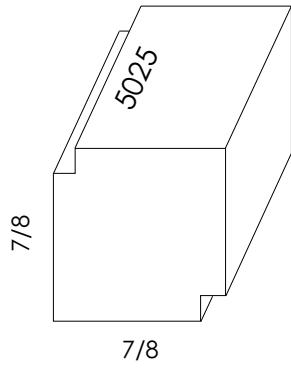
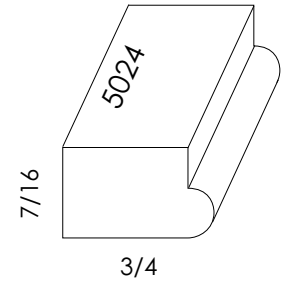
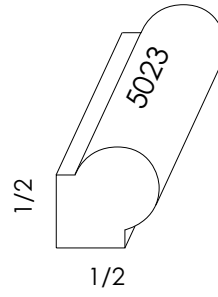
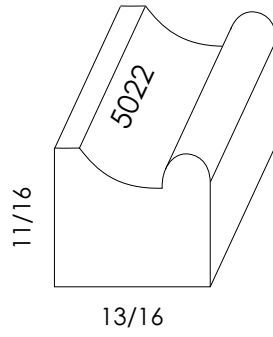
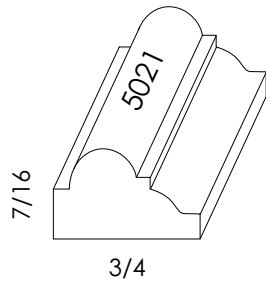
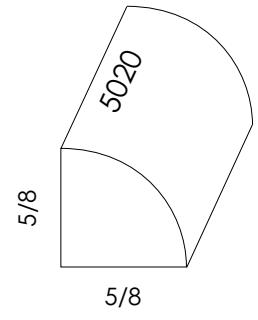
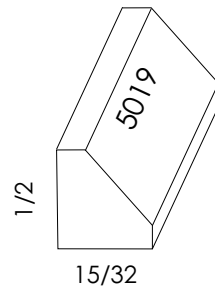
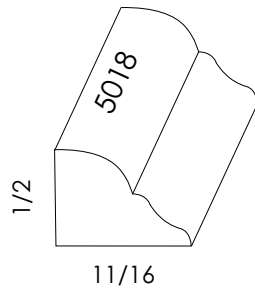
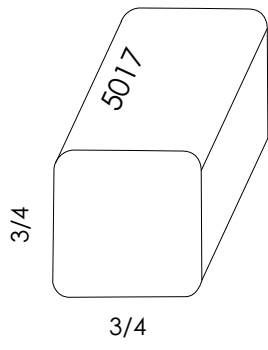

PILOW IIIPWS

Shoe

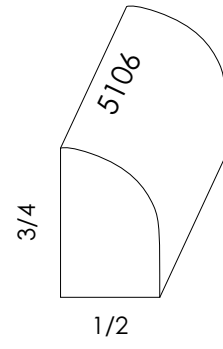
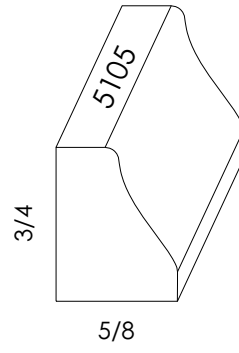
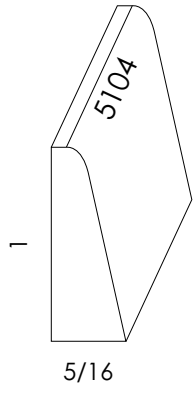
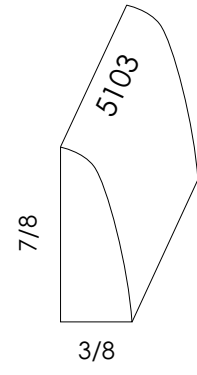
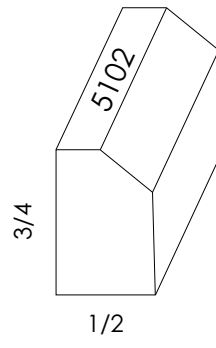
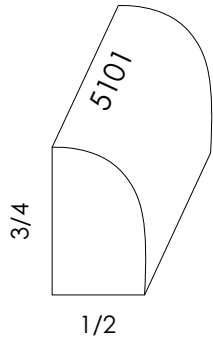

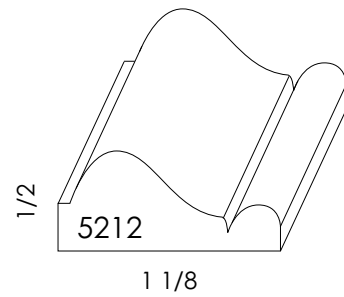
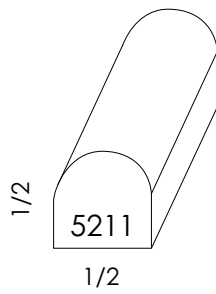
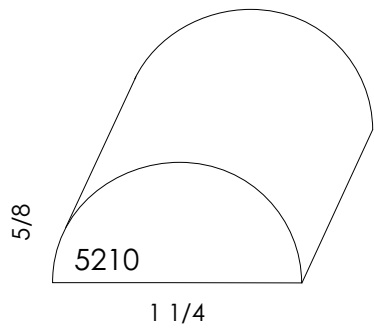
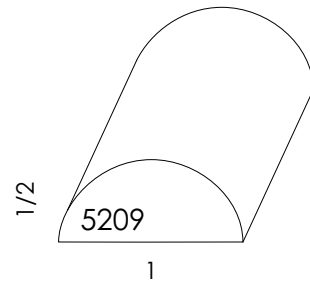
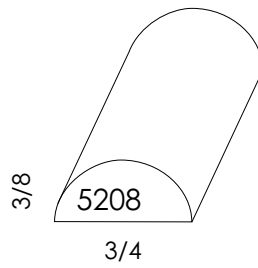
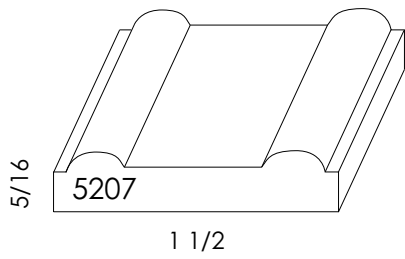
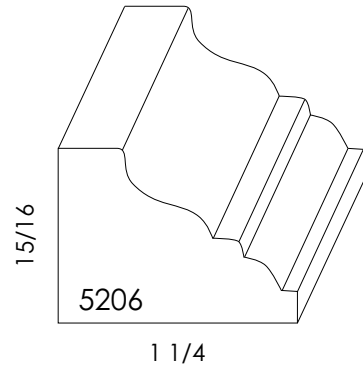
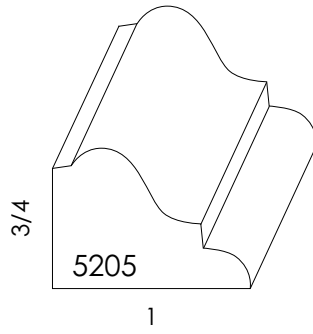
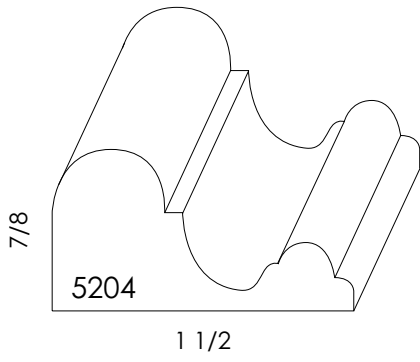
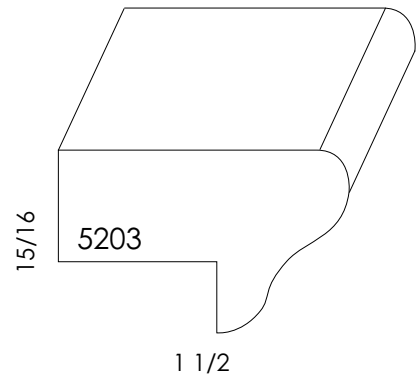
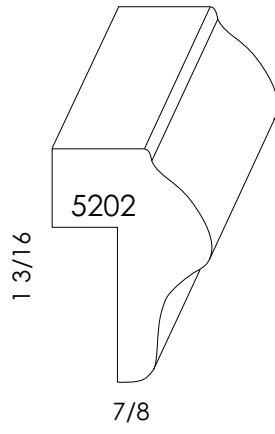
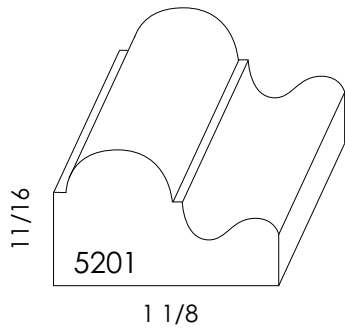

Panel Mold

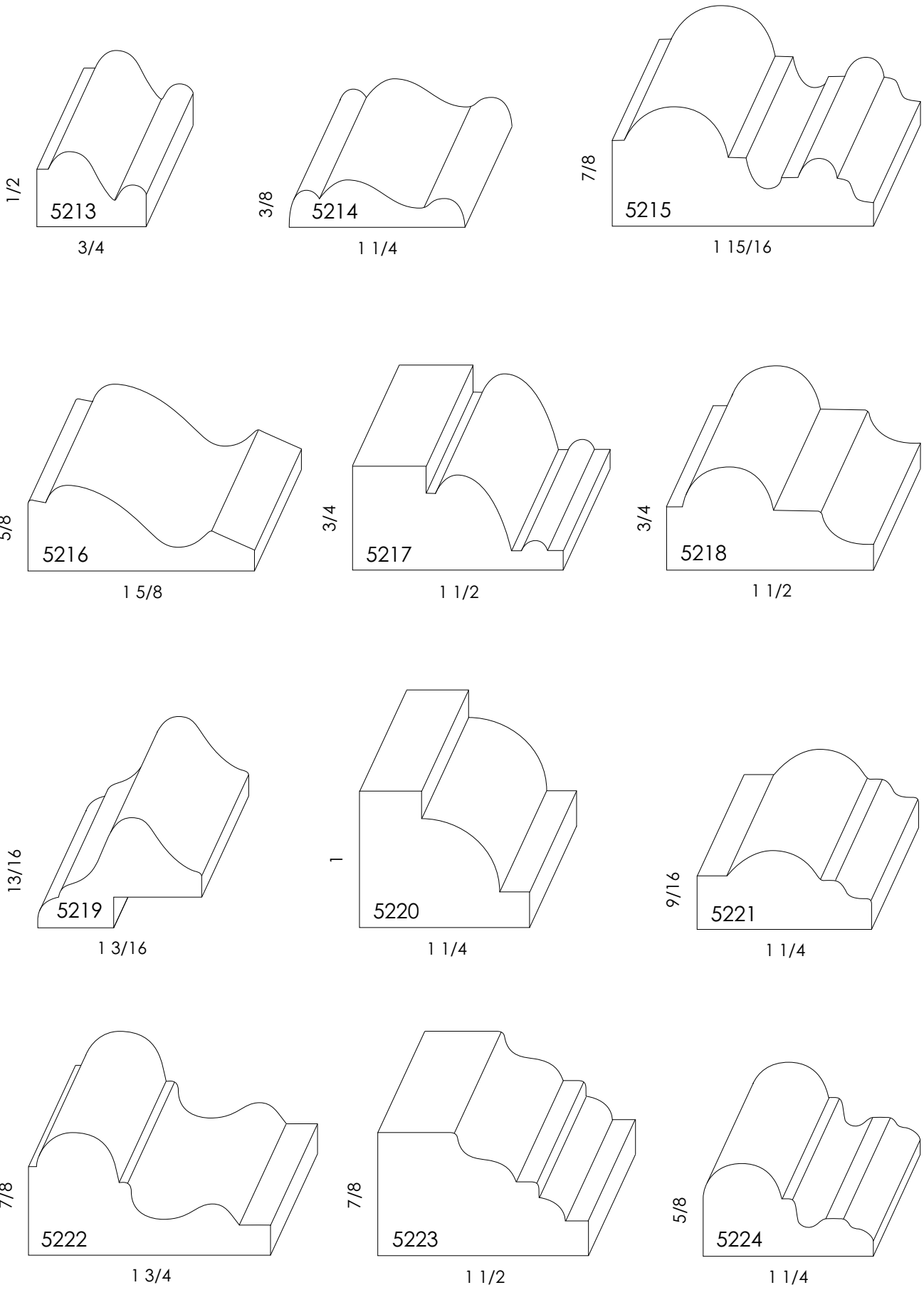

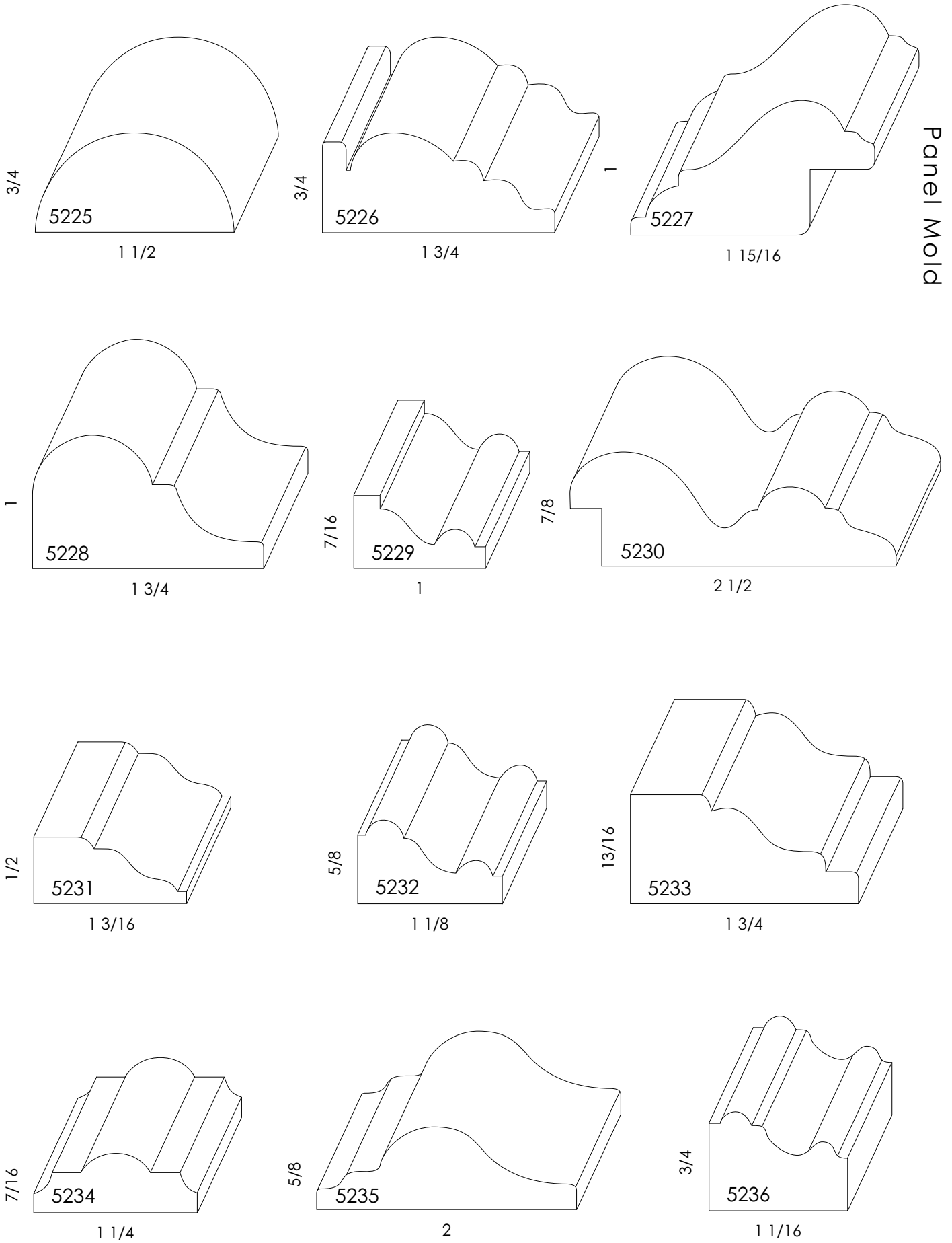

Panel Mold

Panel Mold

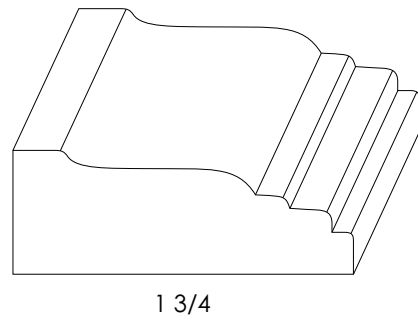
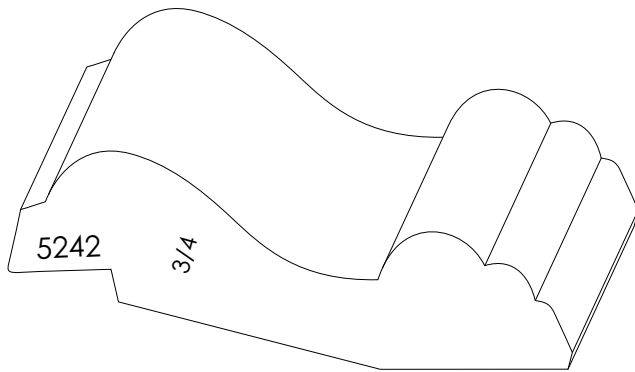
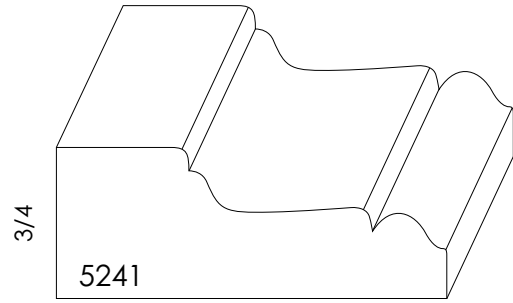
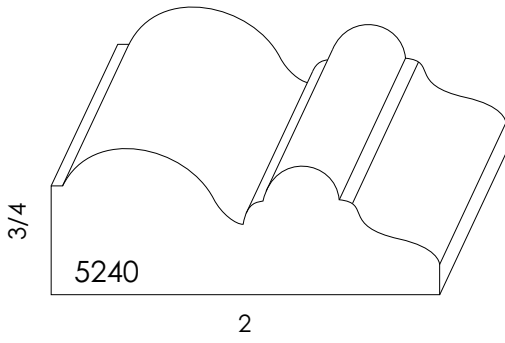
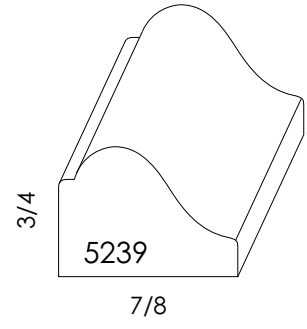
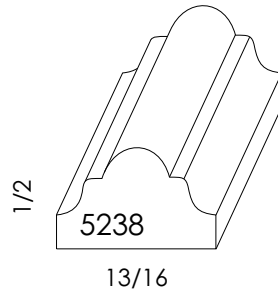
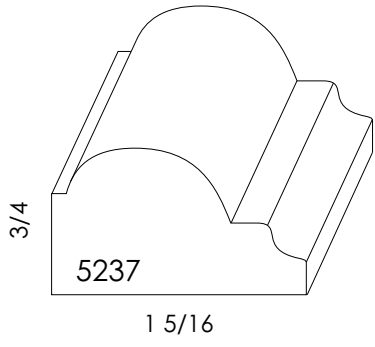

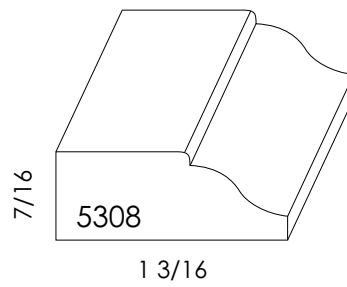
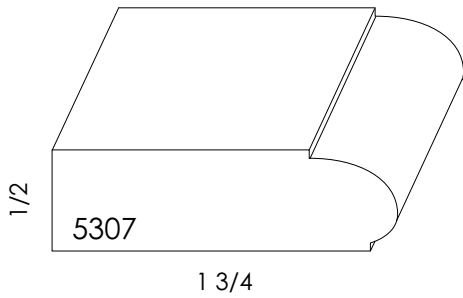
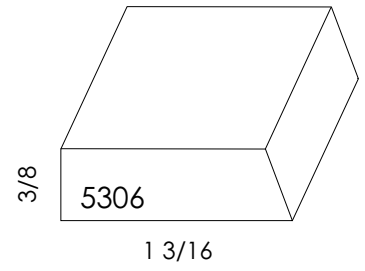
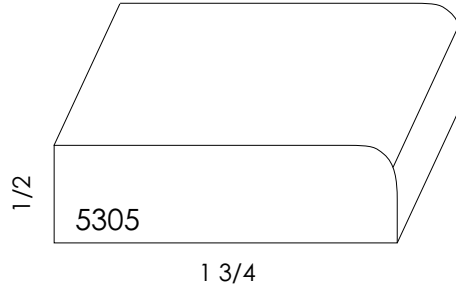
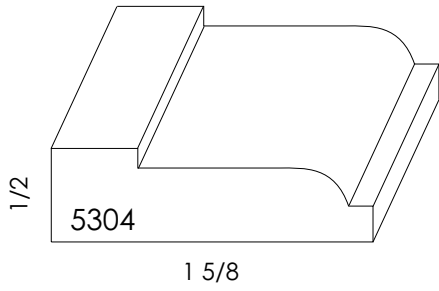
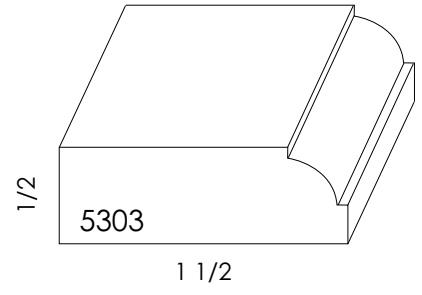
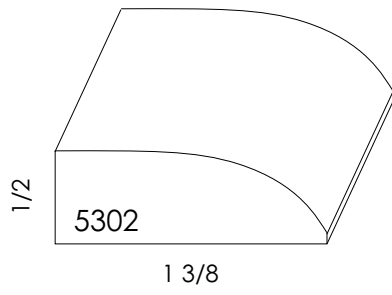
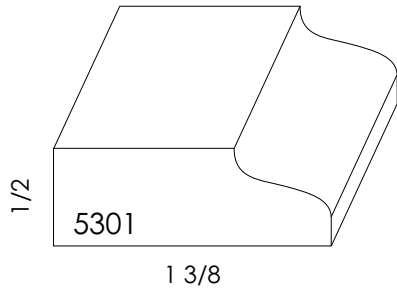

Base Cap

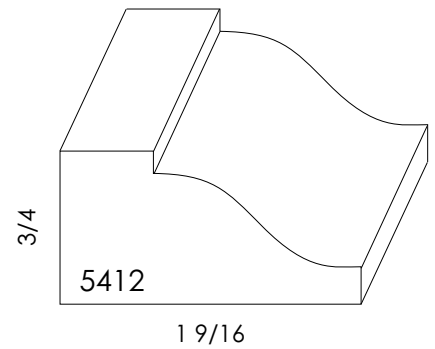
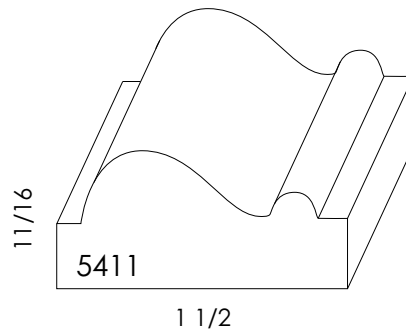
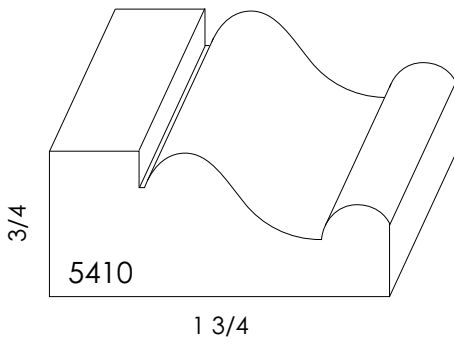
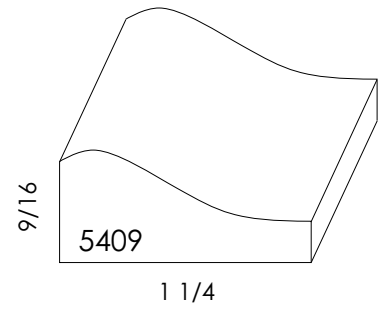
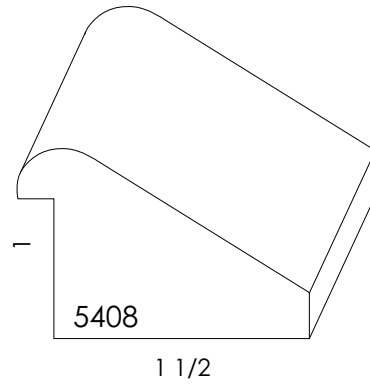
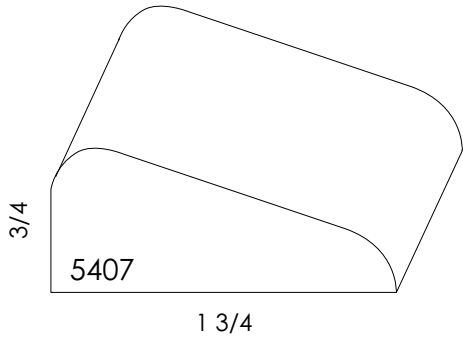
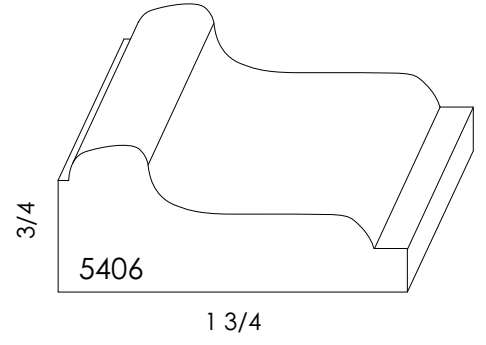
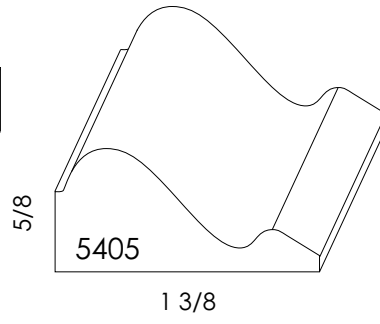
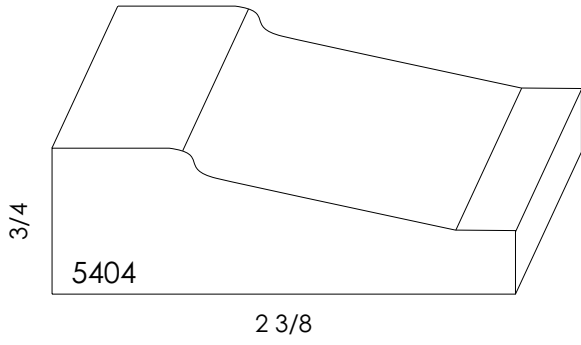
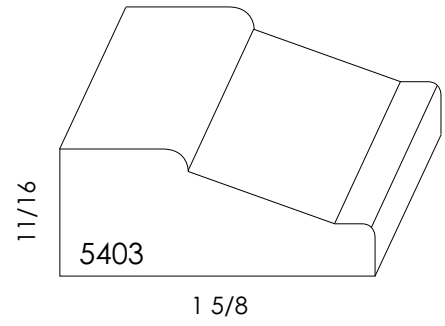
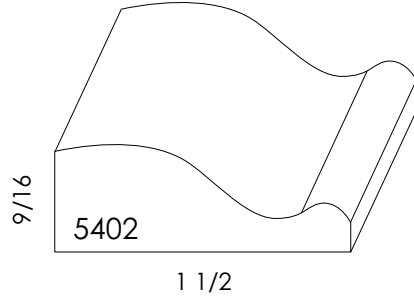
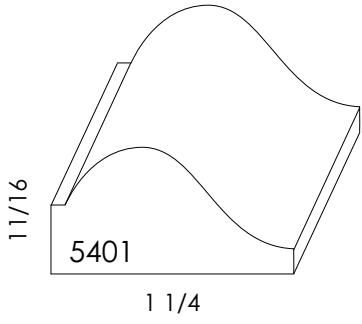

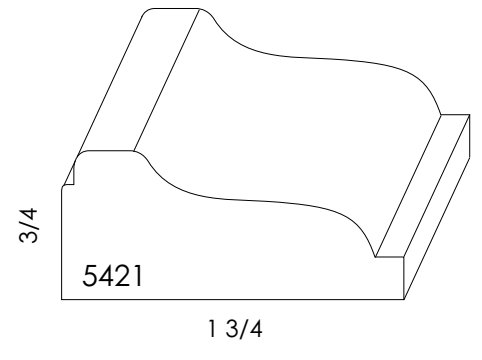
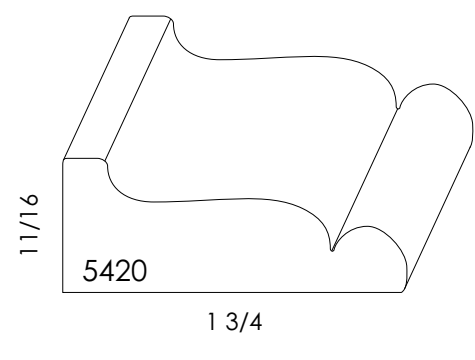
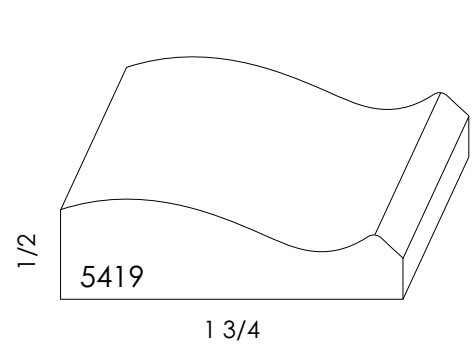
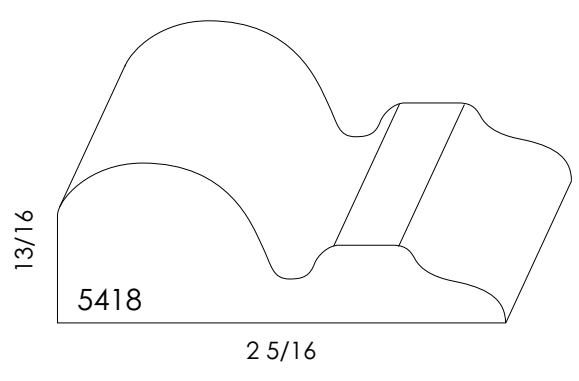
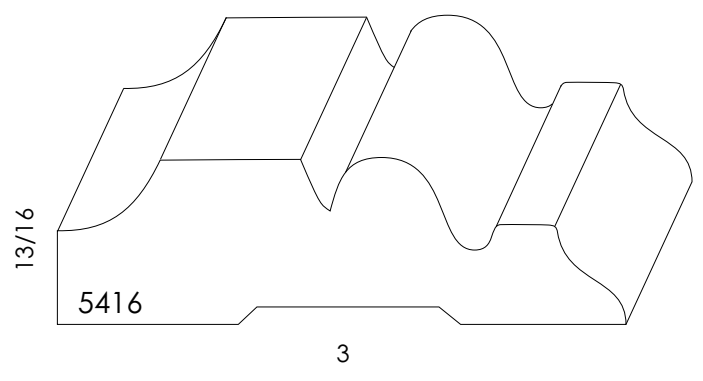
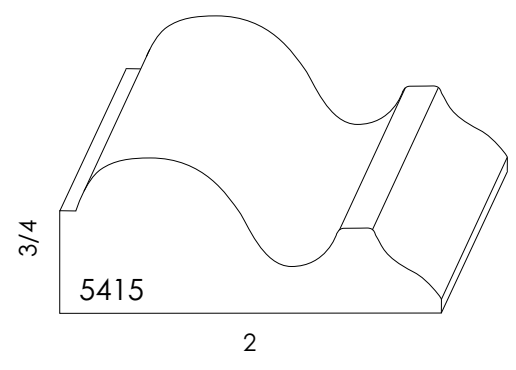
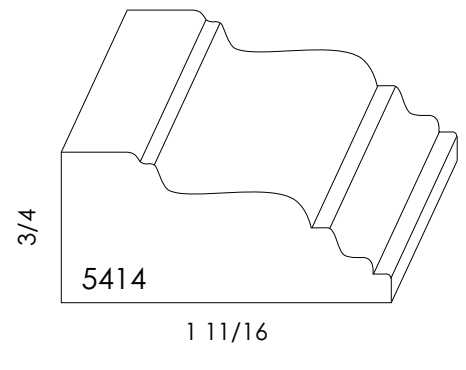
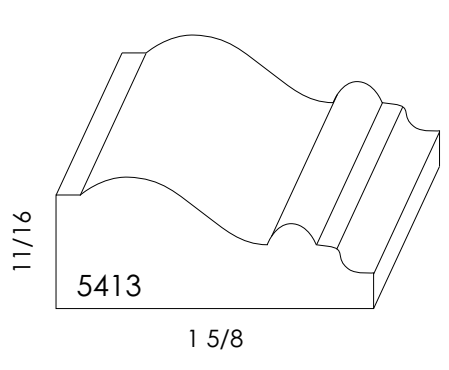

Base Cap

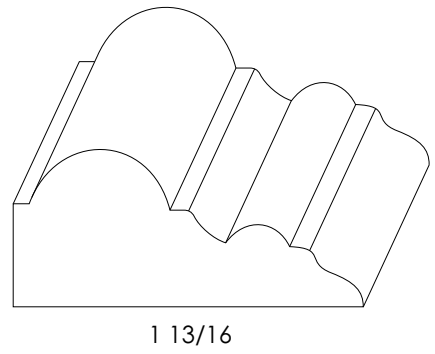
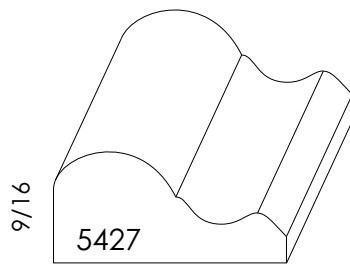
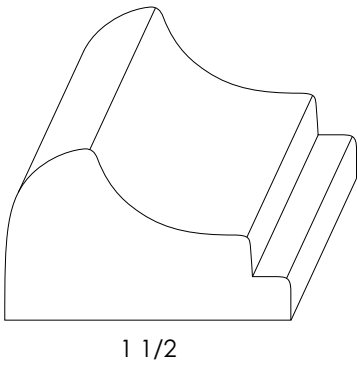
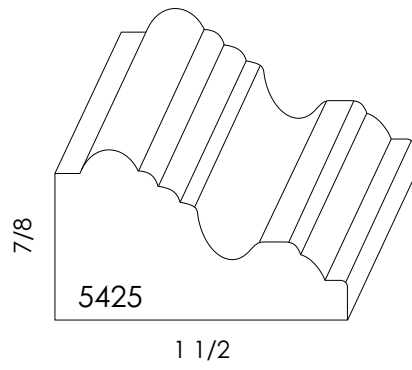
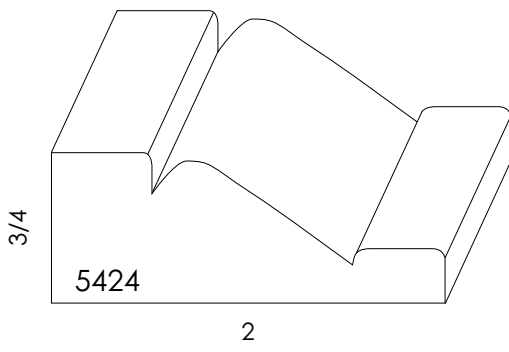
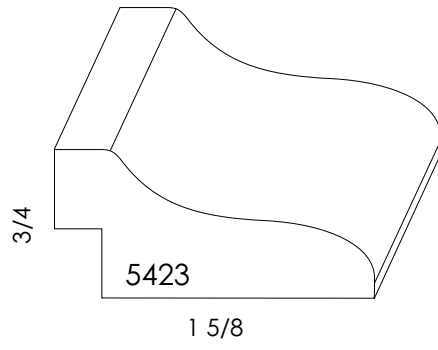
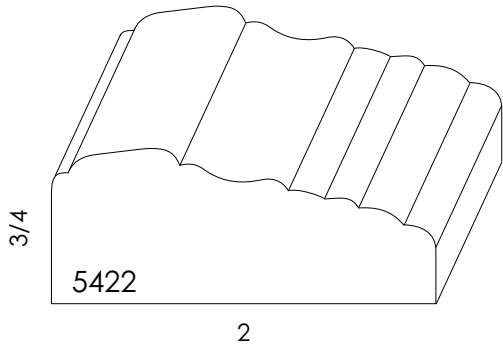

Outside Corner

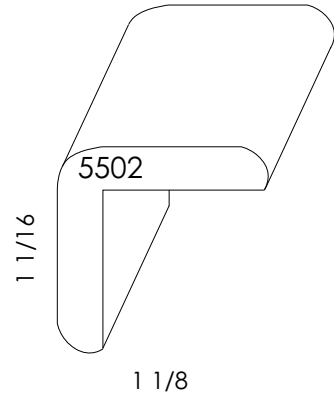
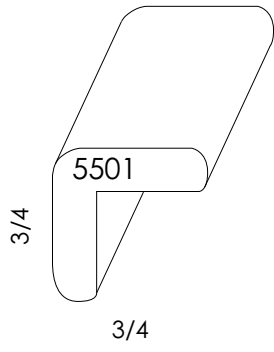

Handrail

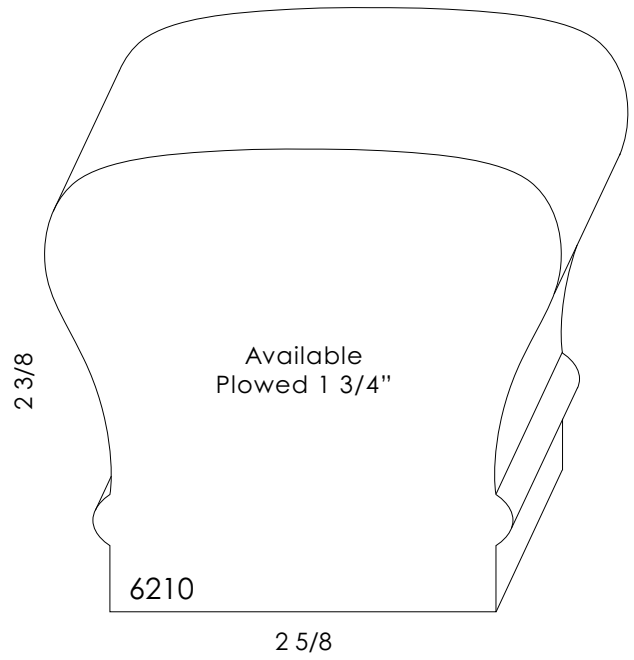
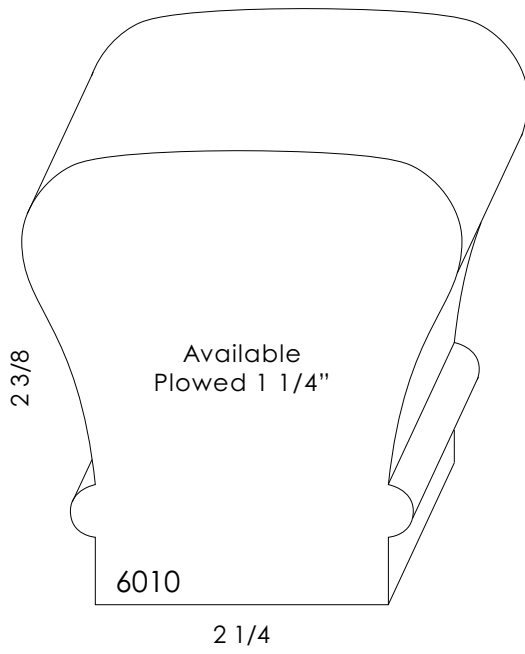

Handrail

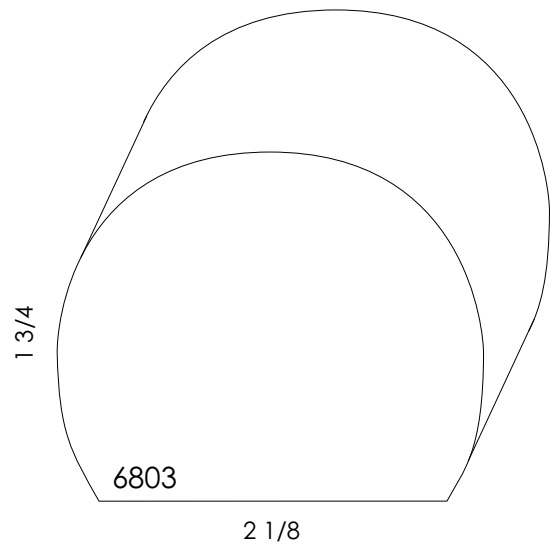
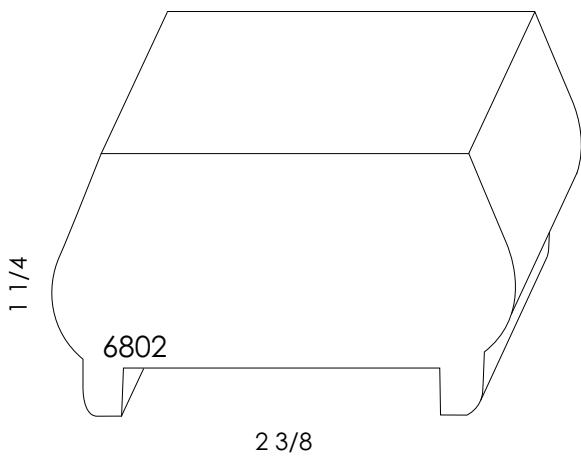
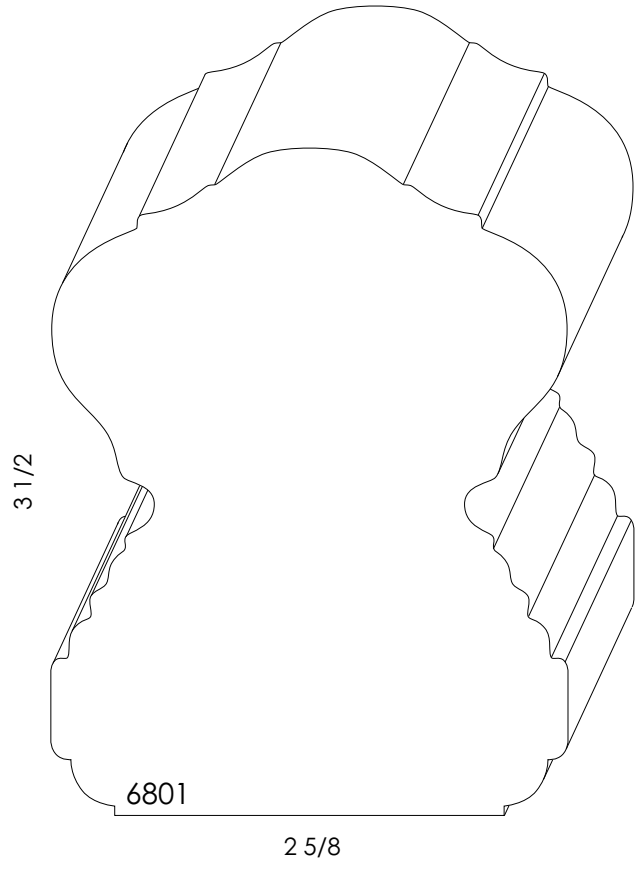
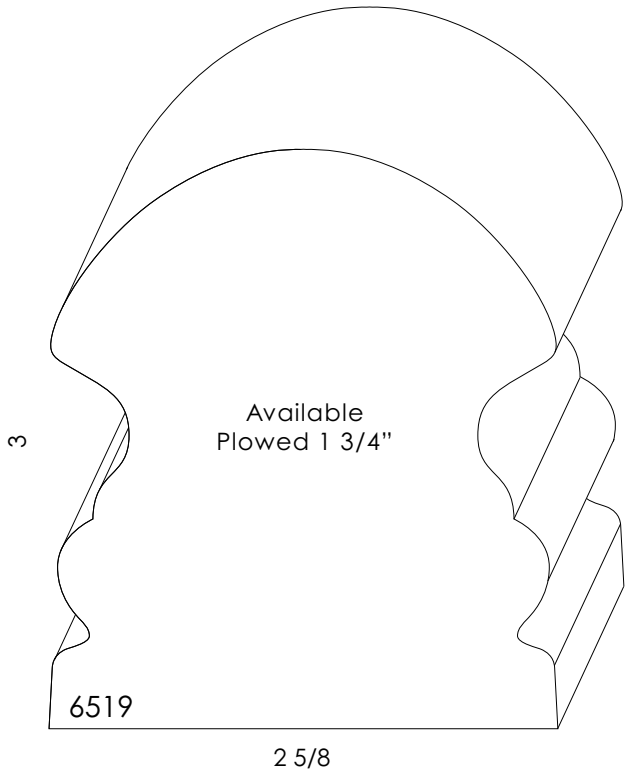

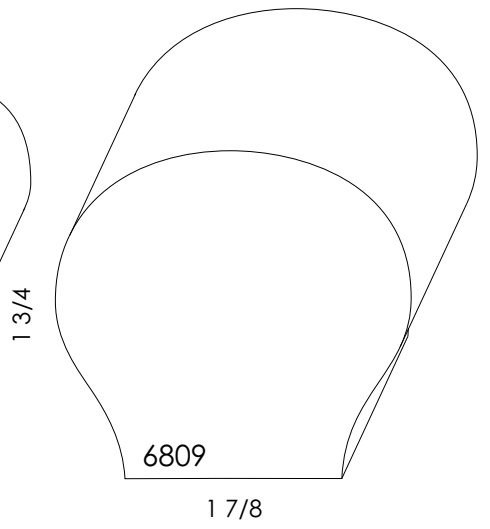
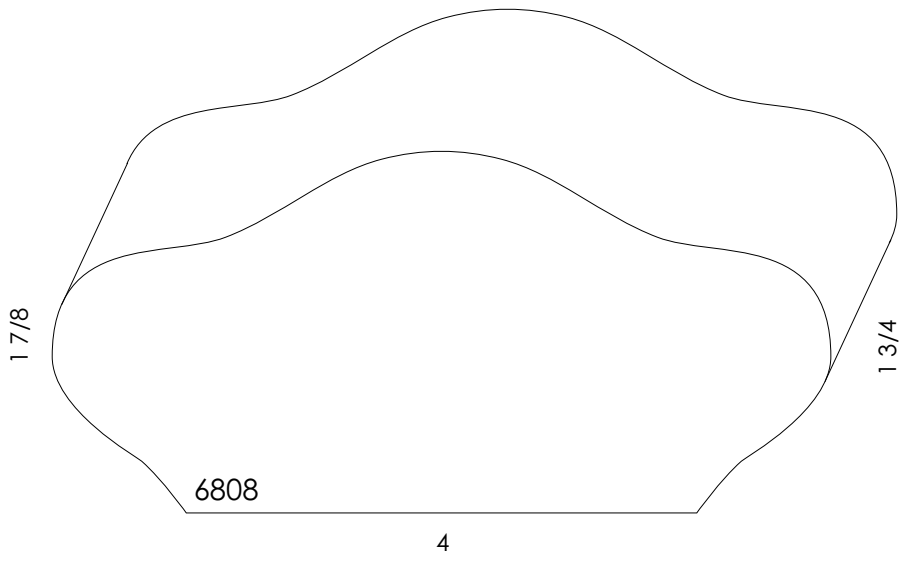
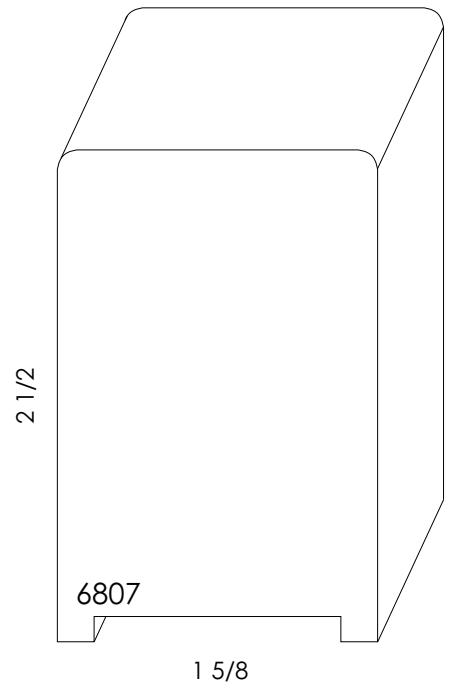
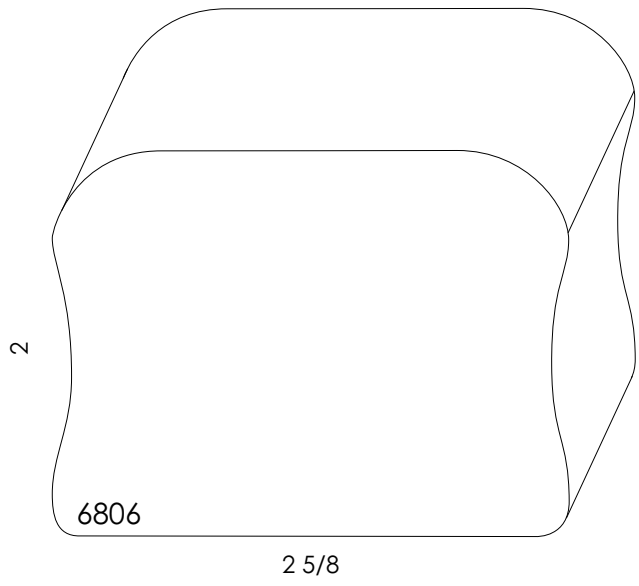
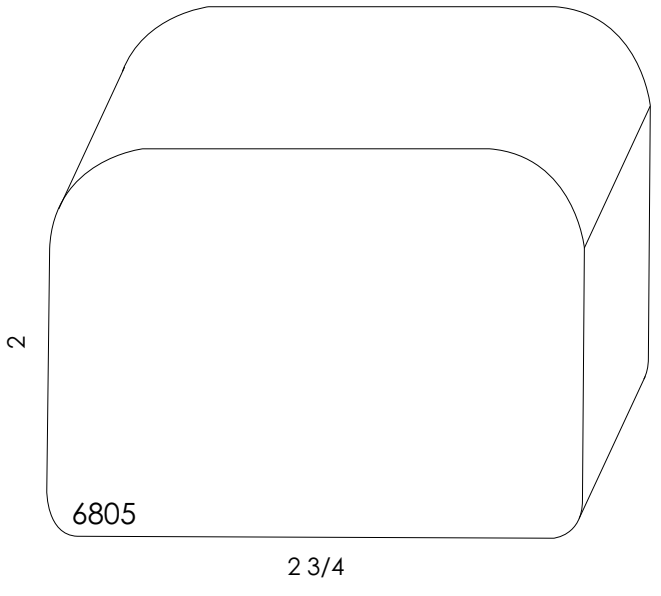
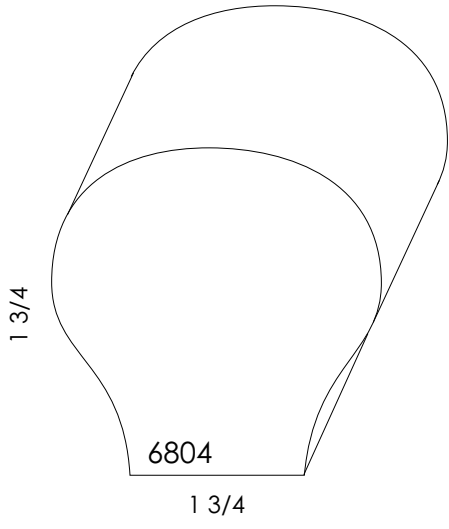

Handrail

$2 \frac{3}{8}$

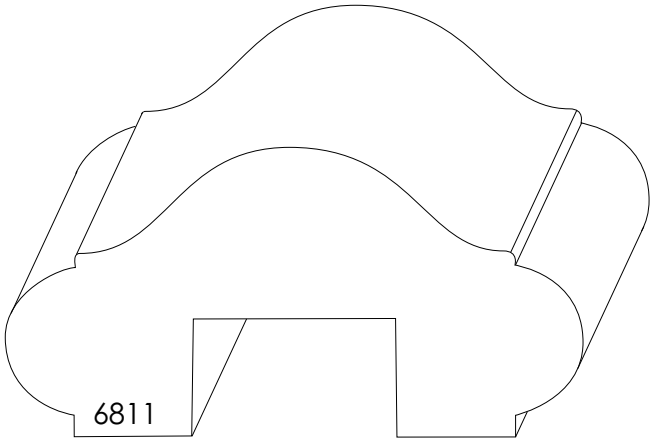
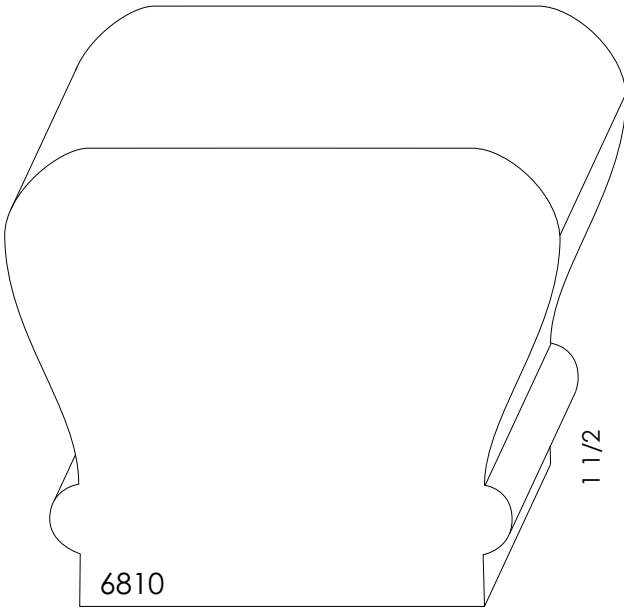

$2 \frac{27}{32}$

3

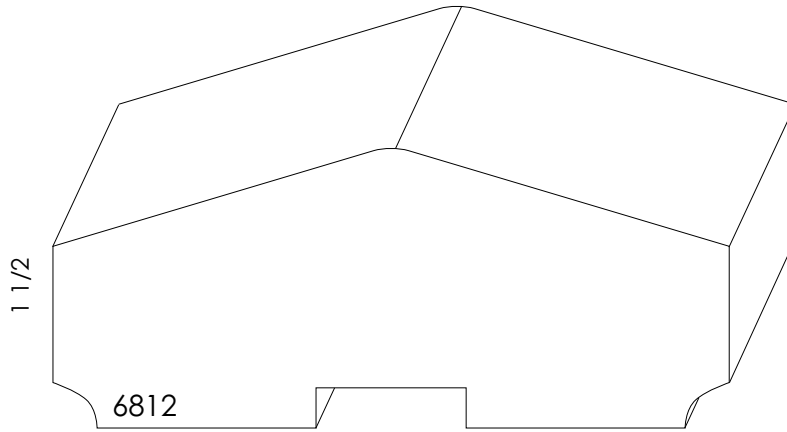

$3 \frac{1}{2}$

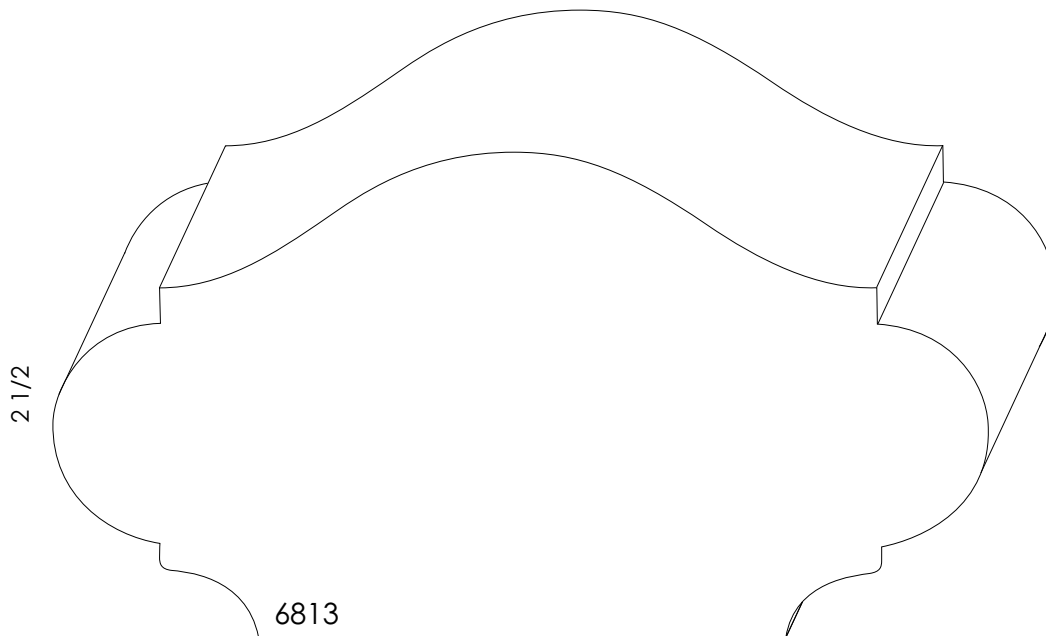

$4 \frac{7}{8}$

Handrail

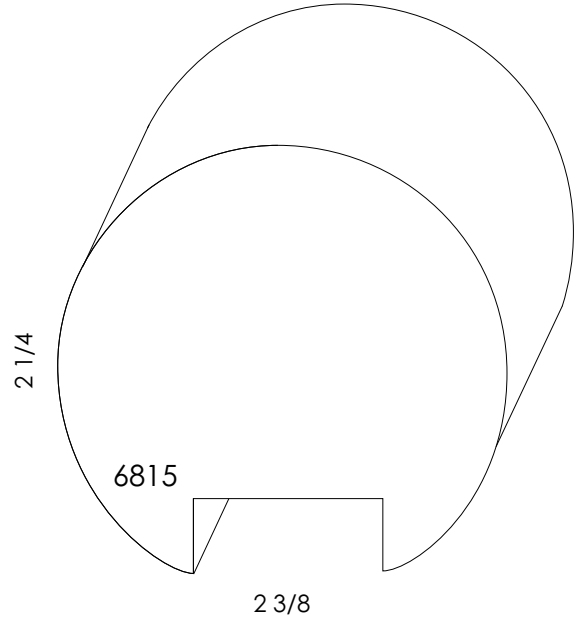
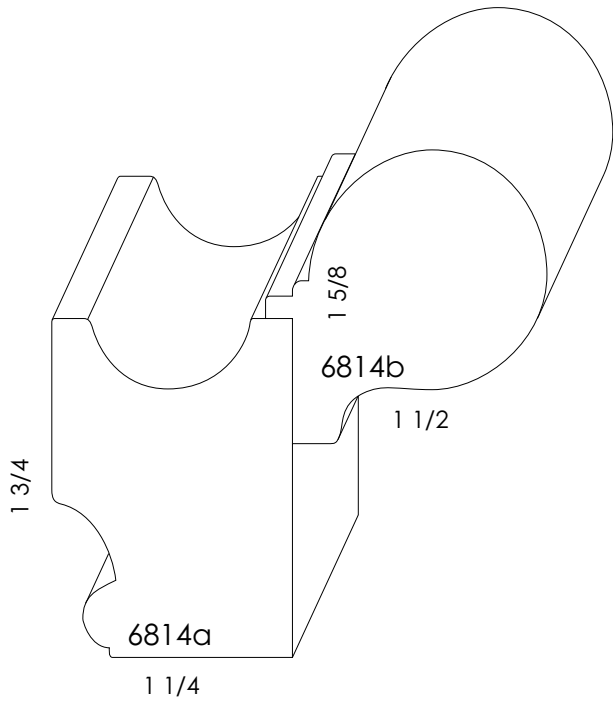

Shoerail

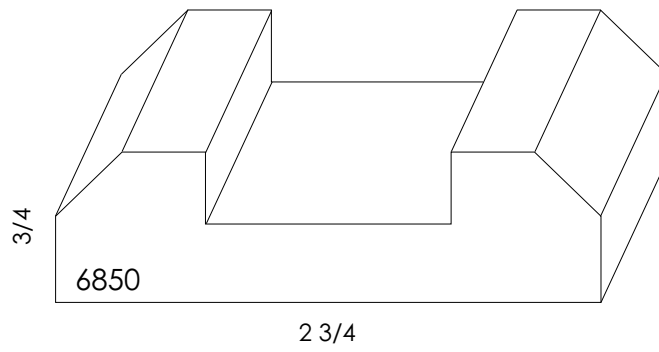
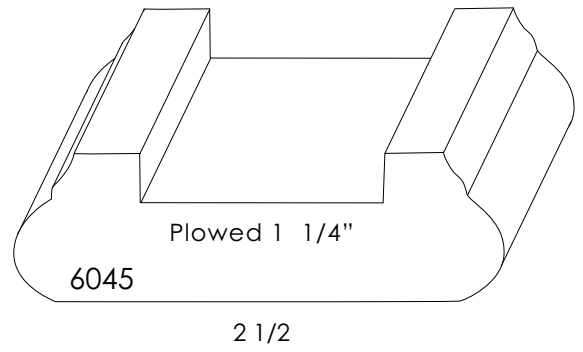
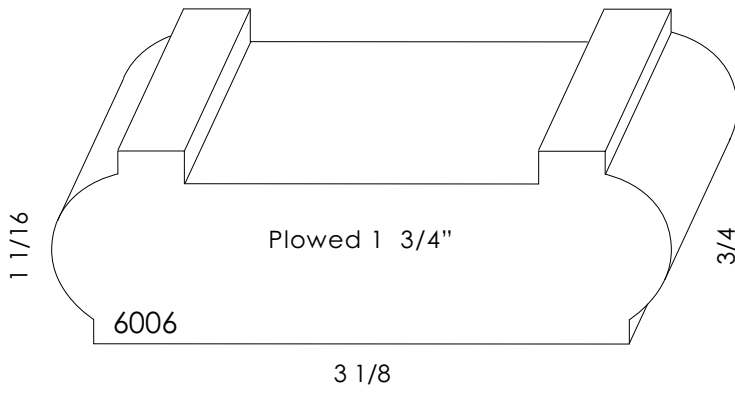

Filler

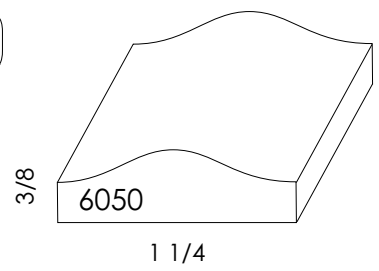
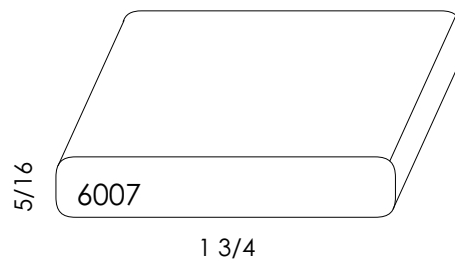
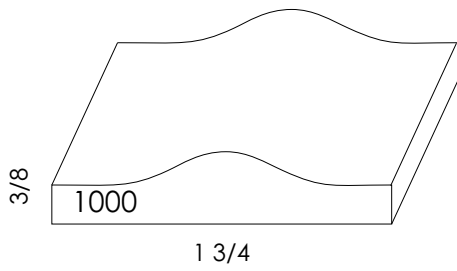

Back Band

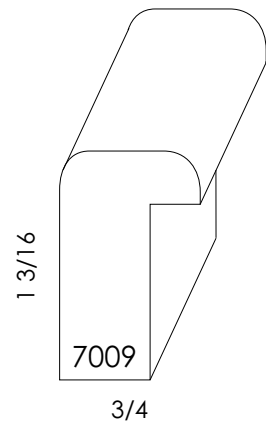
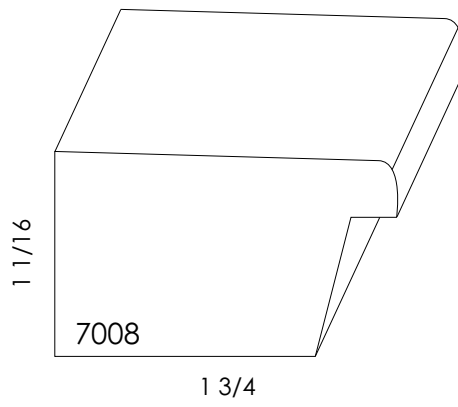
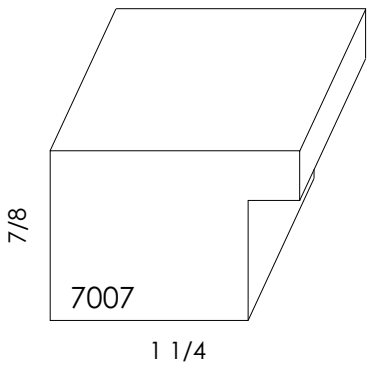
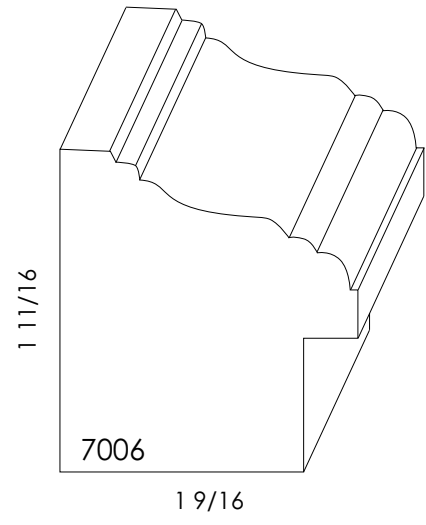
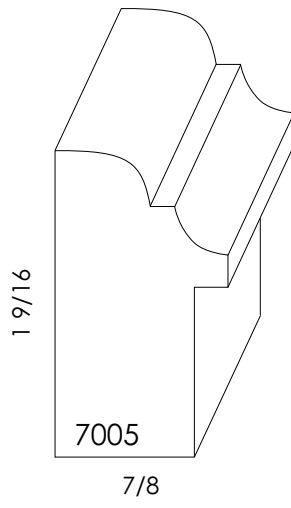
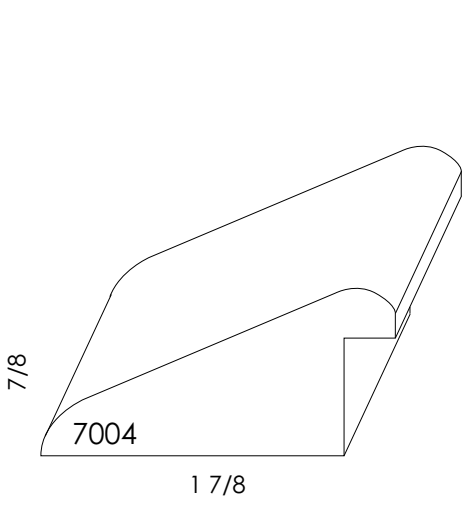
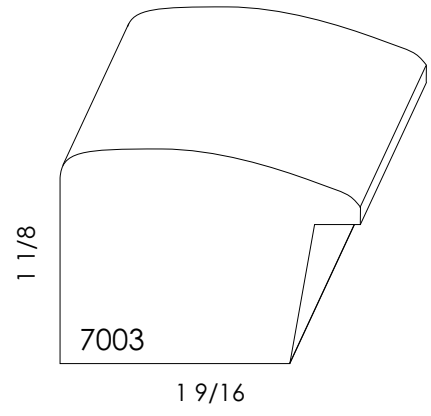
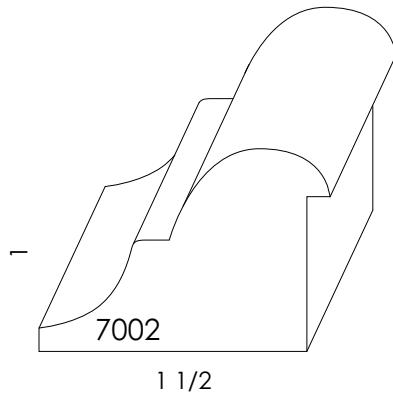
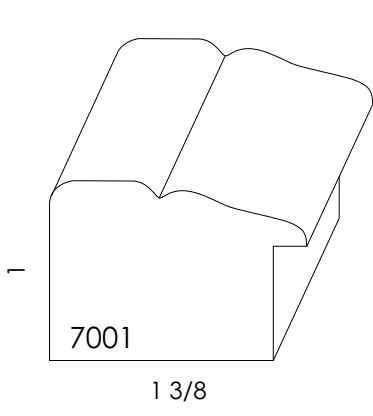

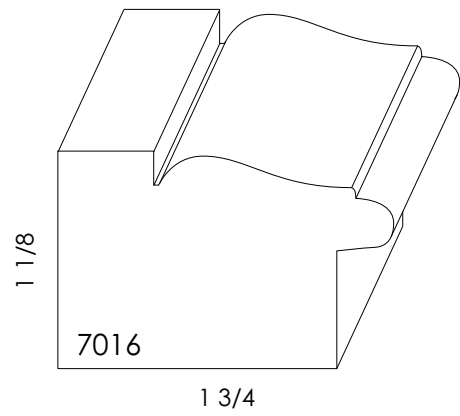
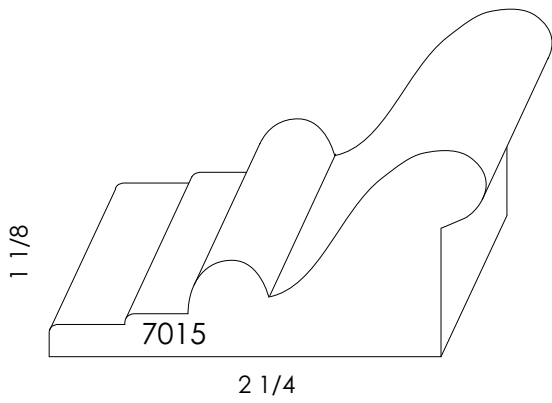
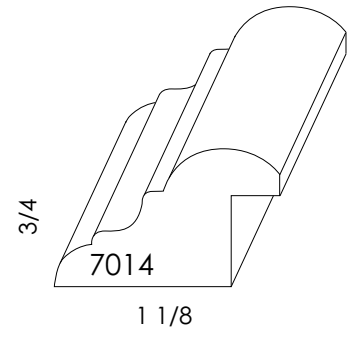
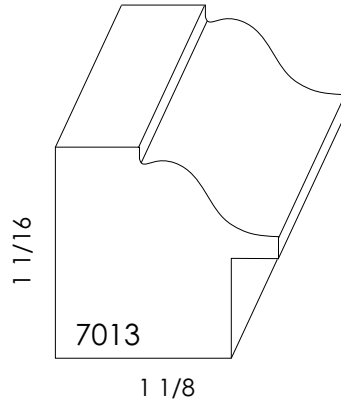
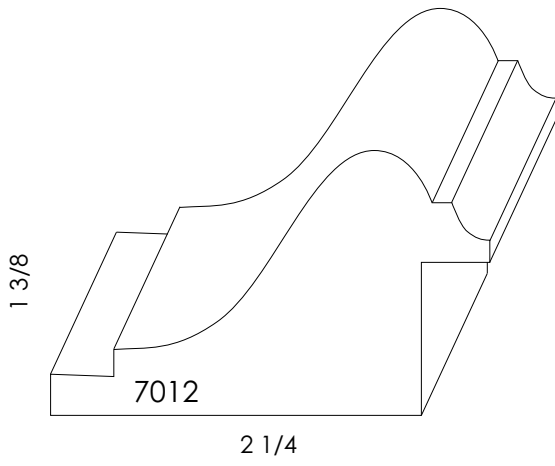
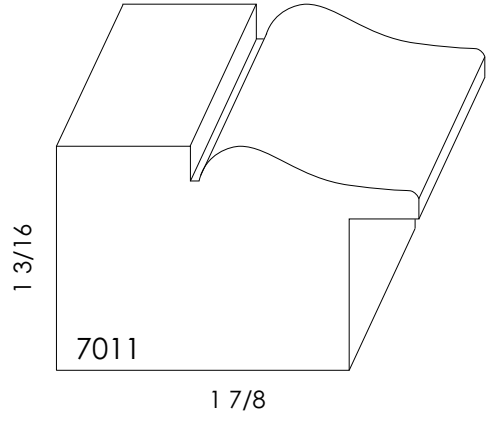
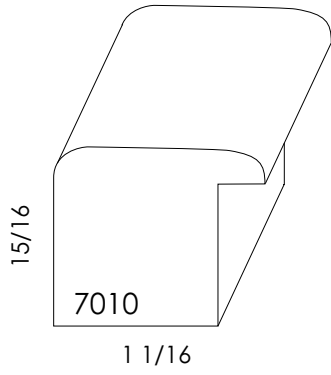

Back Band

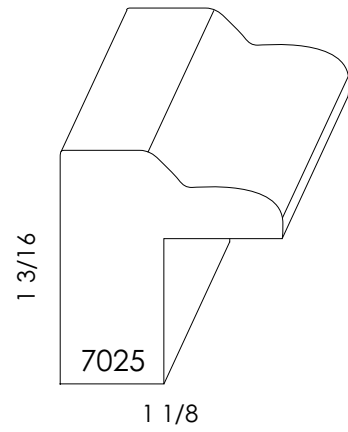
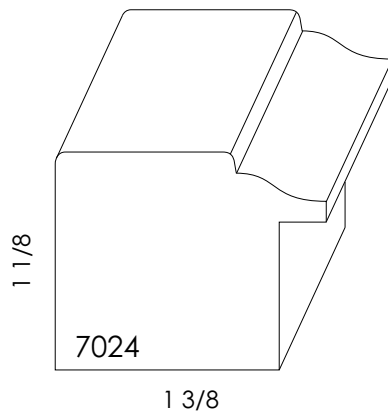
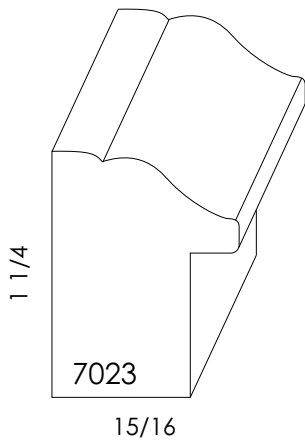
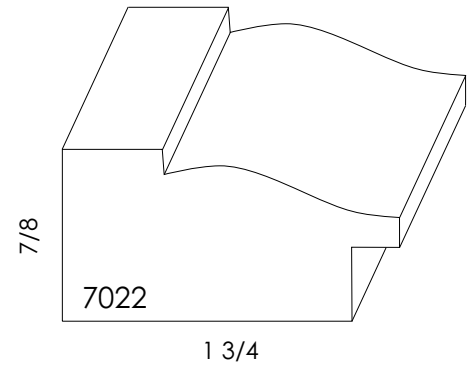
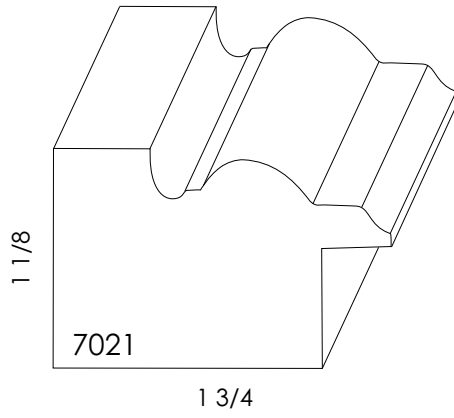
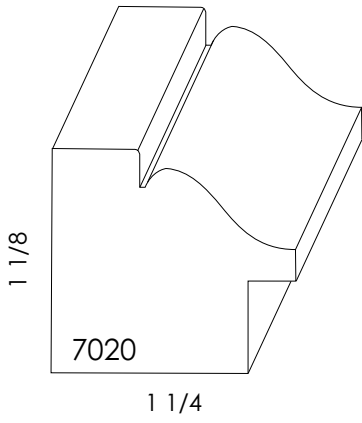
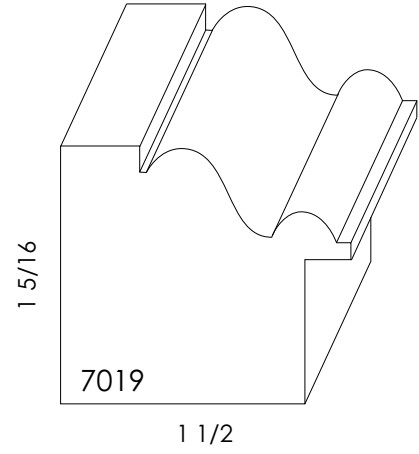
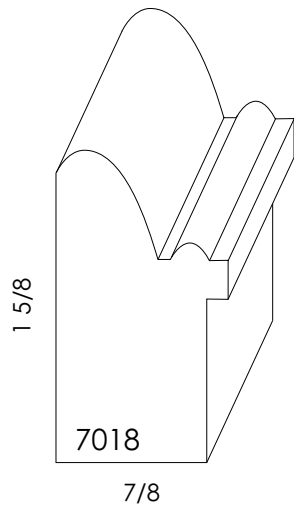
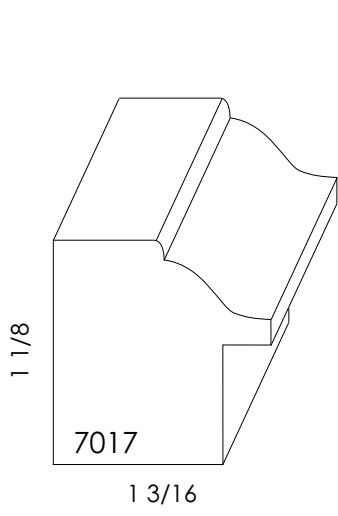

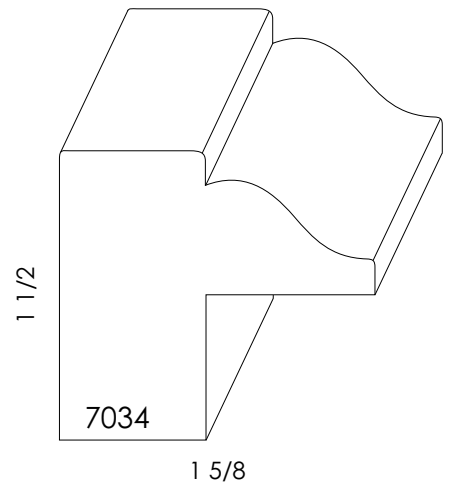
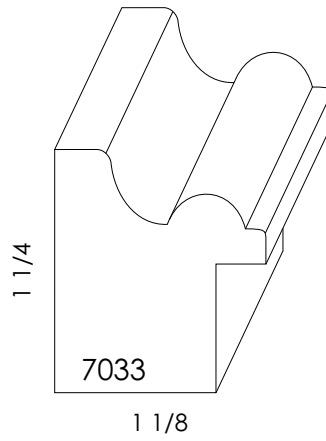
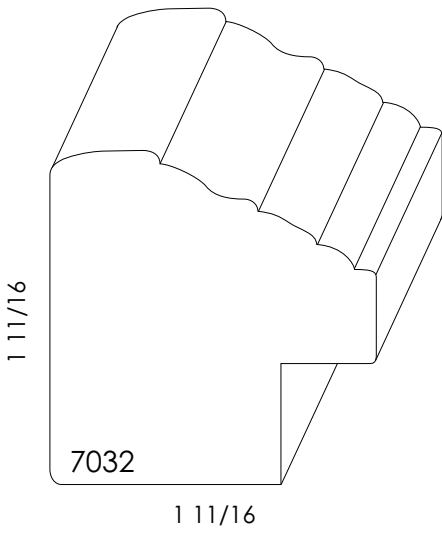
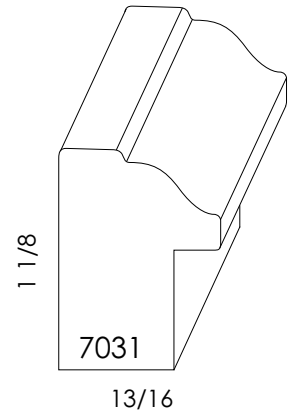
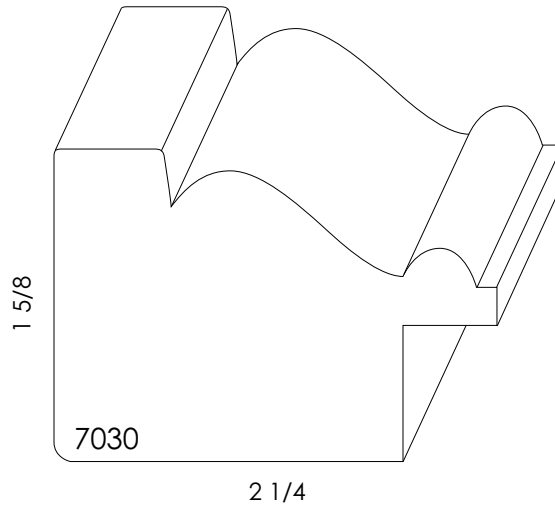
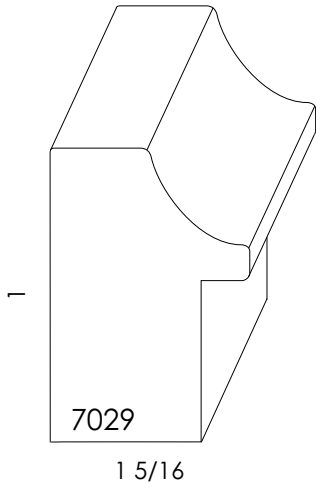
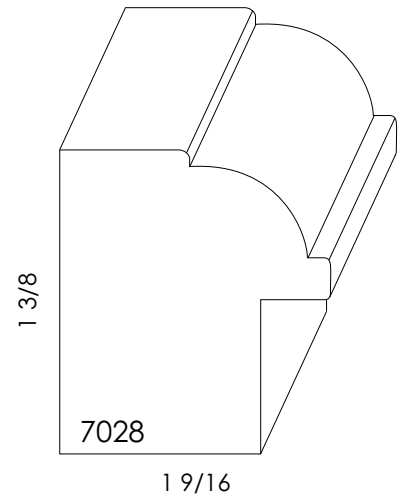
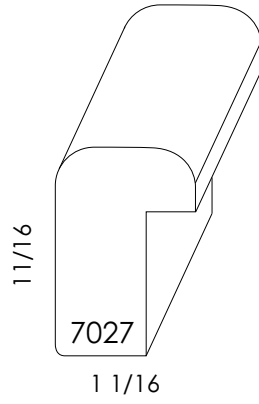
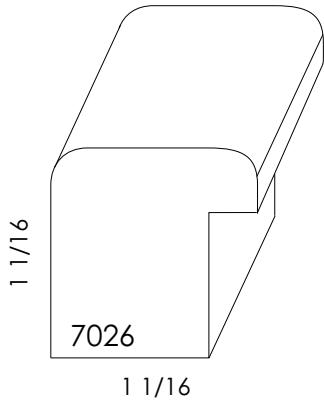

Back Band

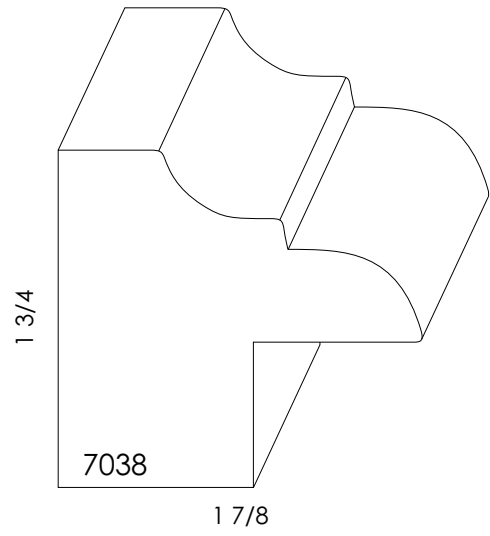
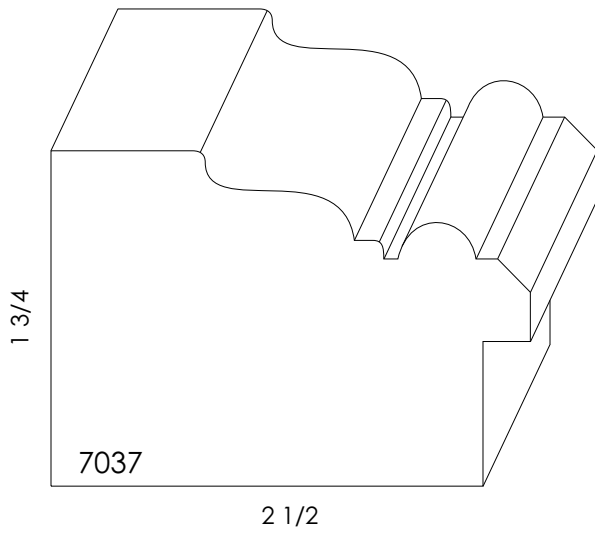
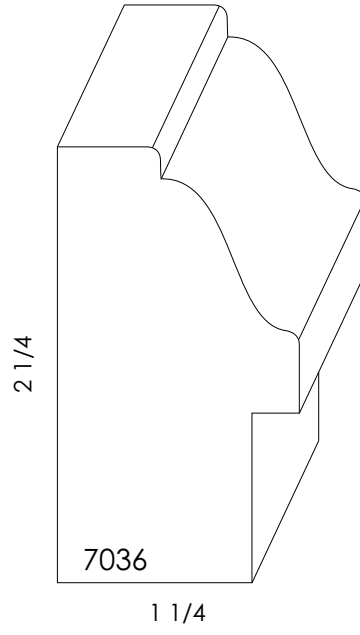
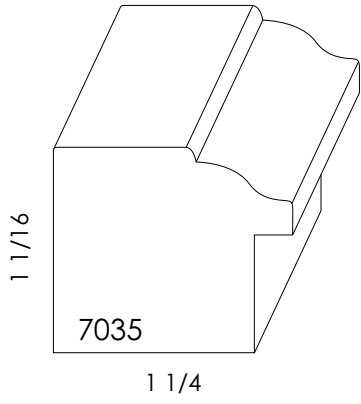

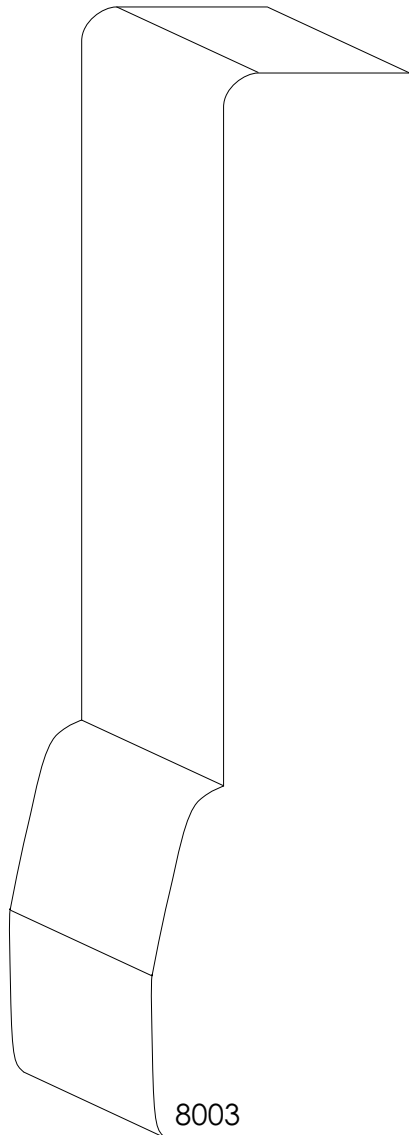
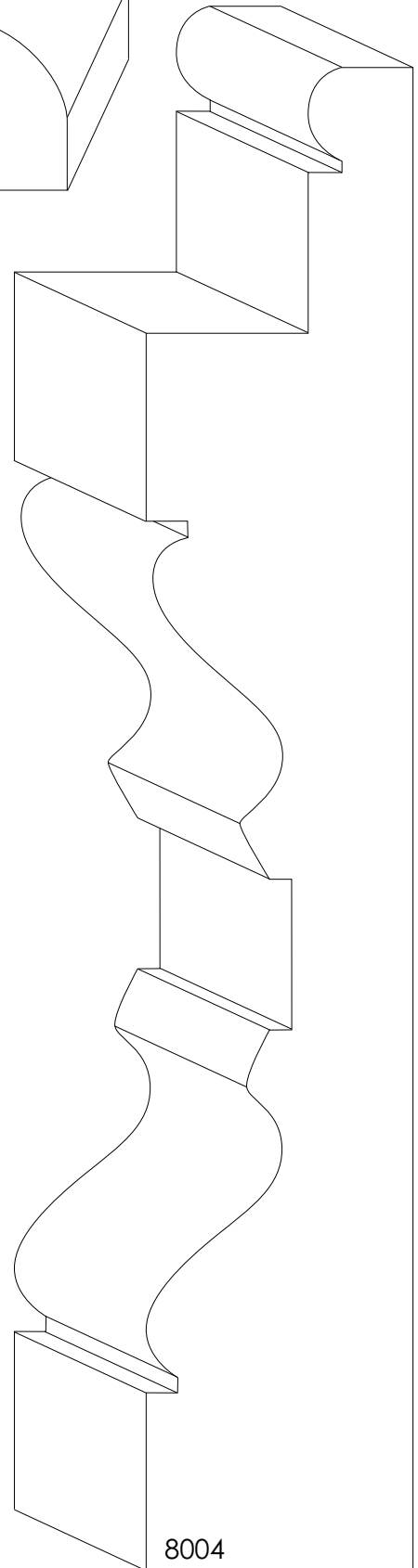
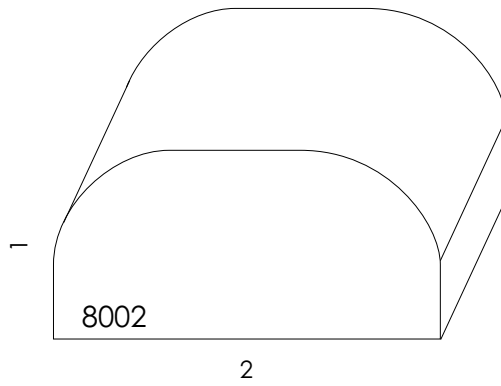
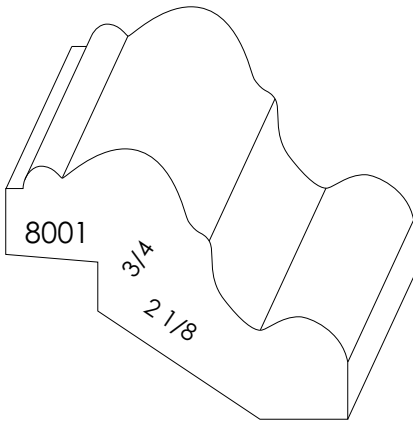

1 5/16

1 1/2

Miscellaneous

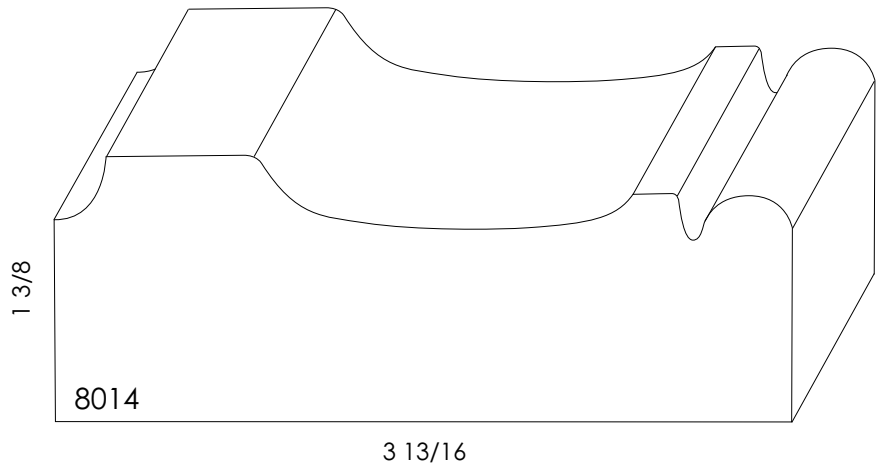
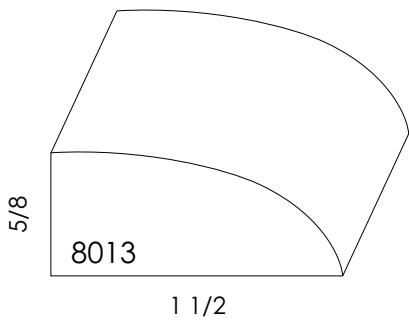
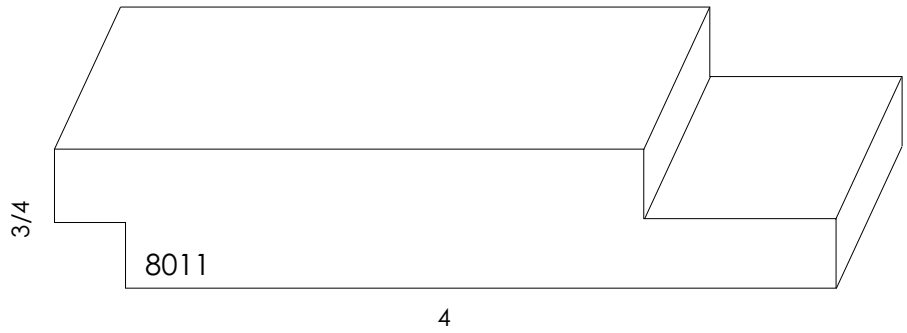
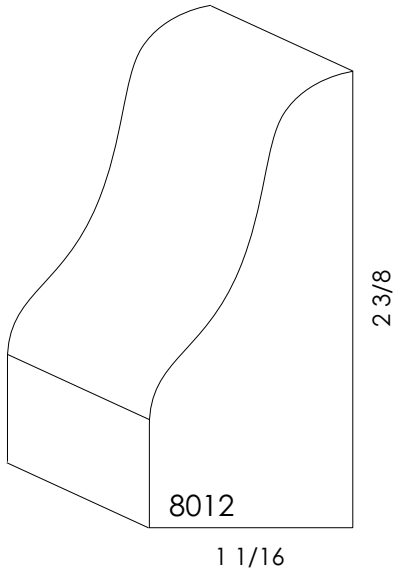
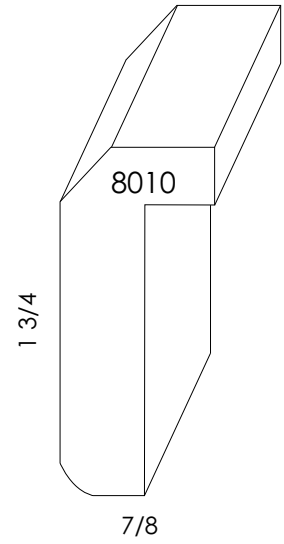
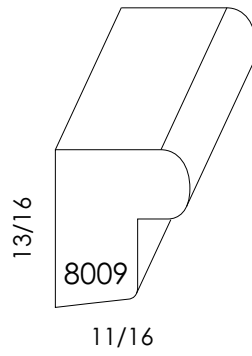
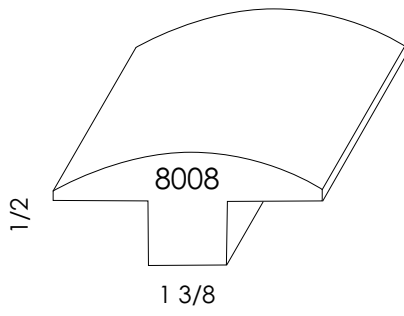
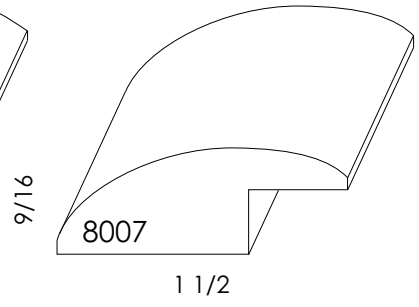
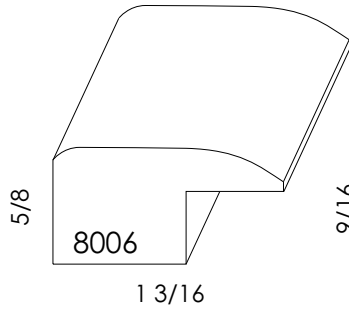
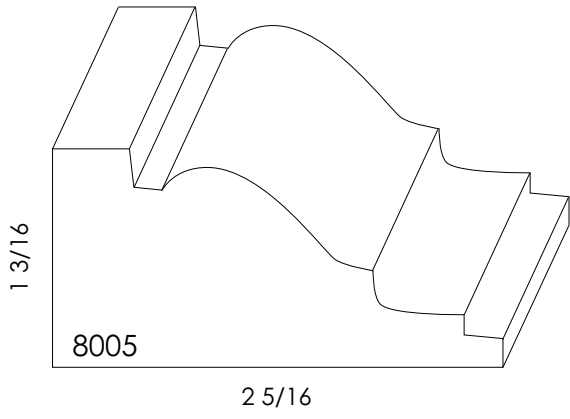

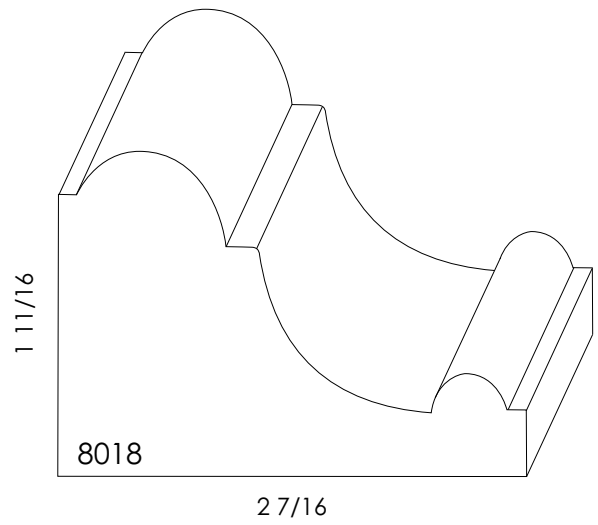
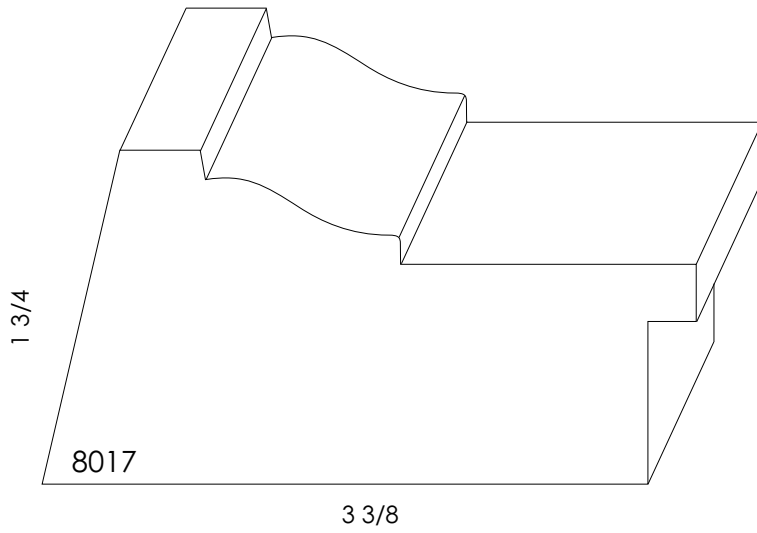
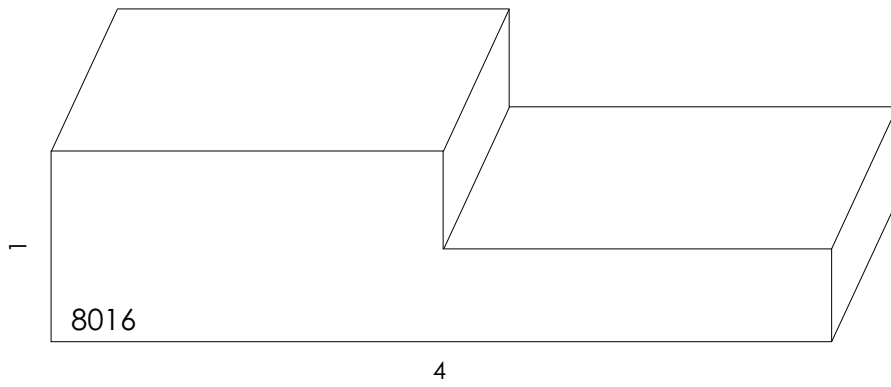
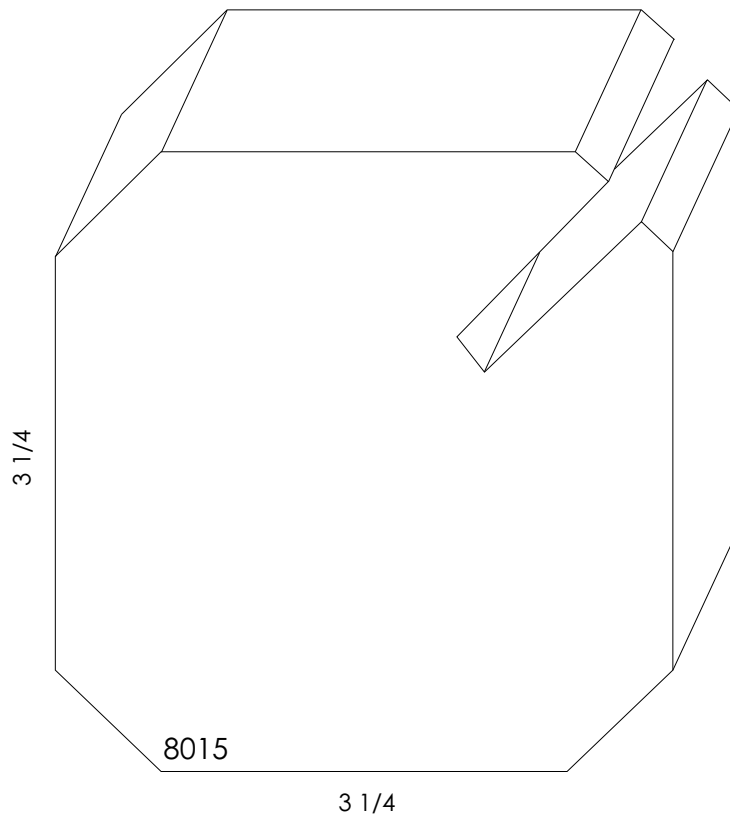

Miscellaneous

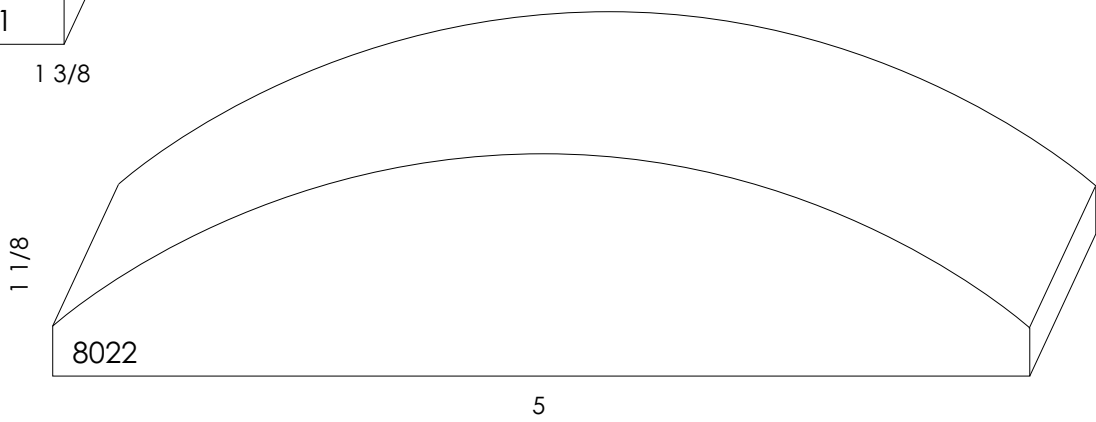
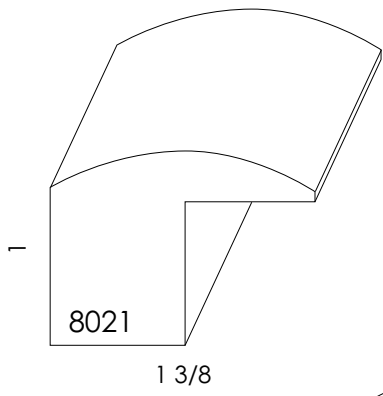
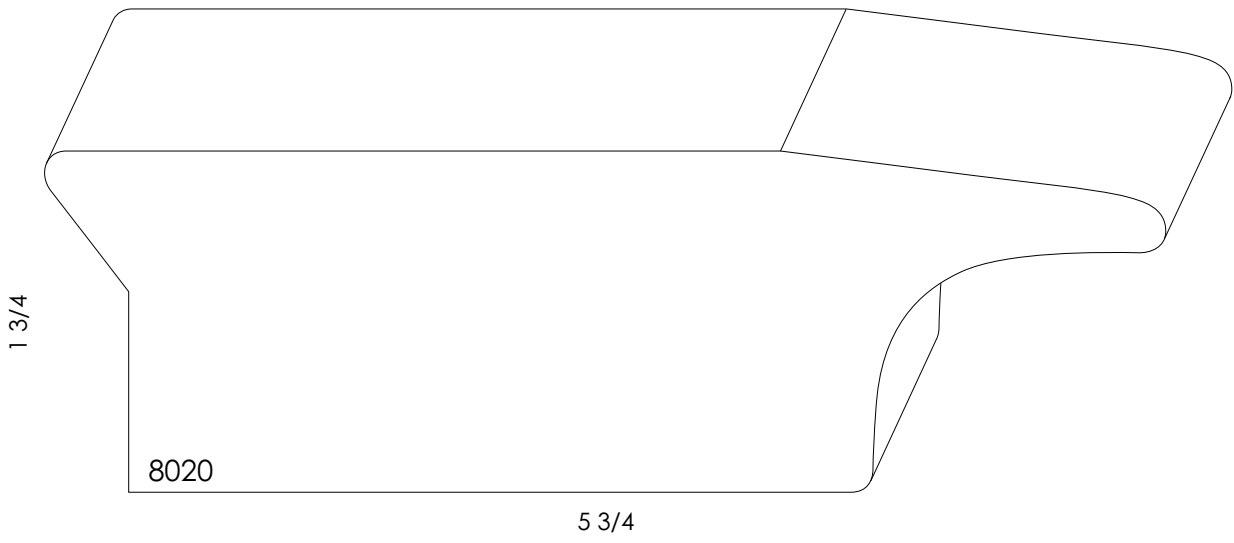
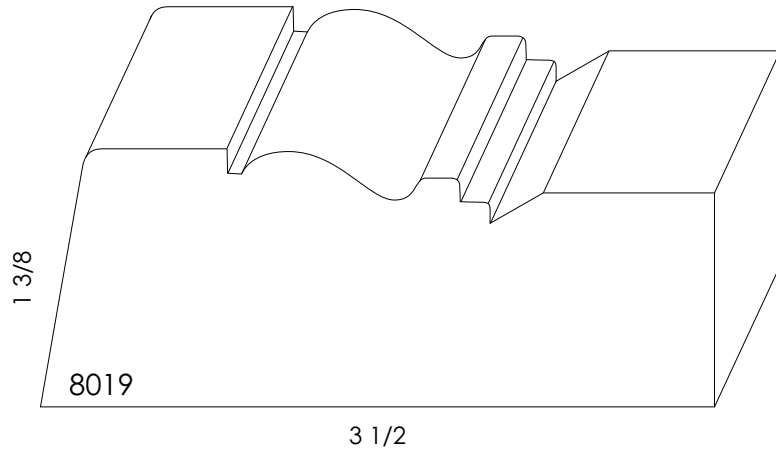

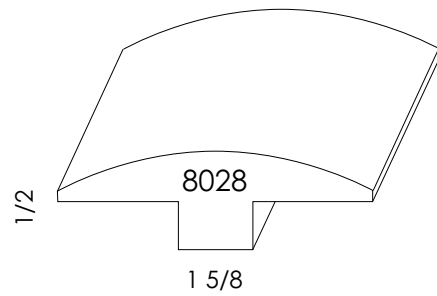
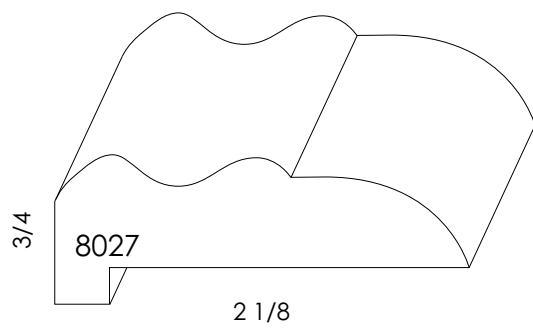
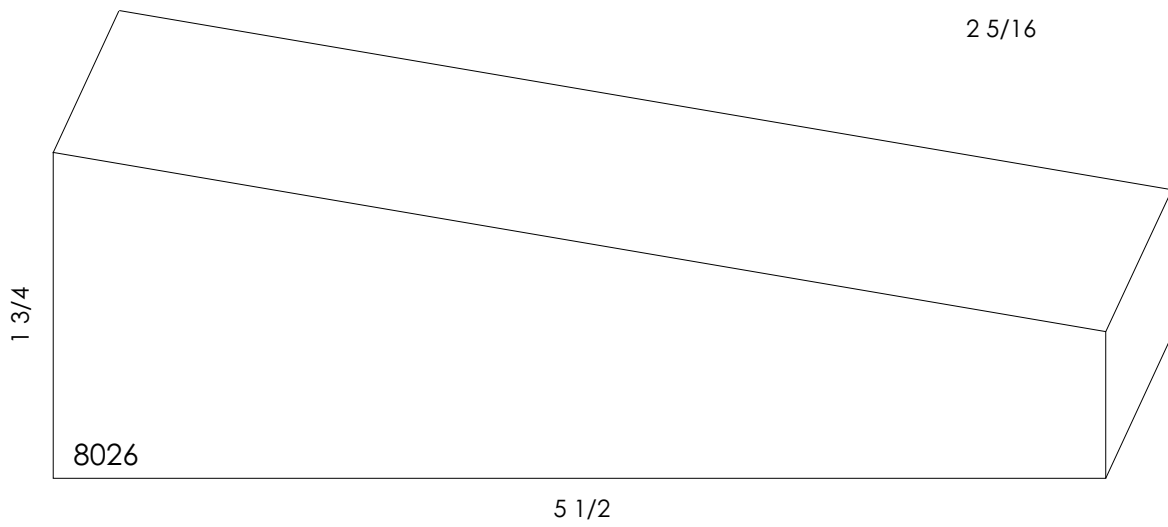
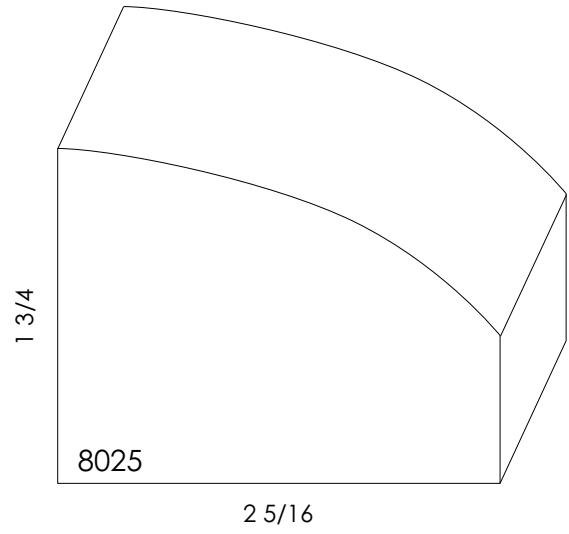
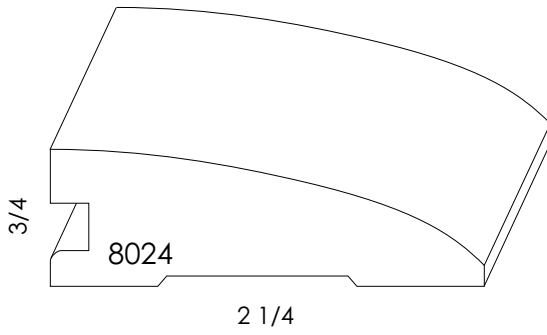
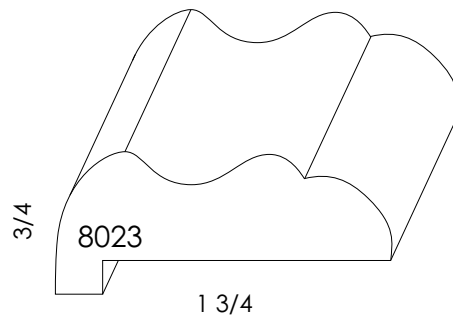

Miscellaneous

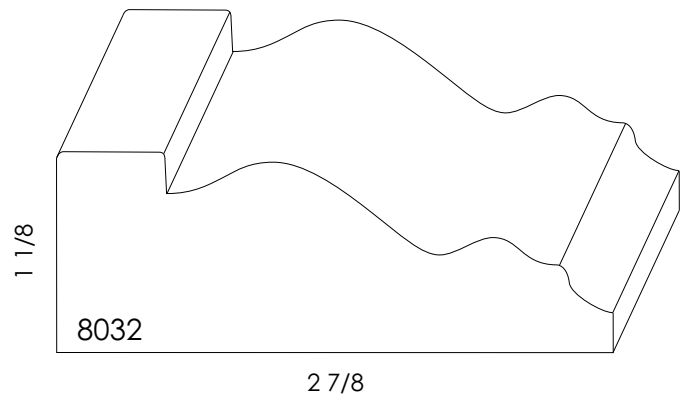
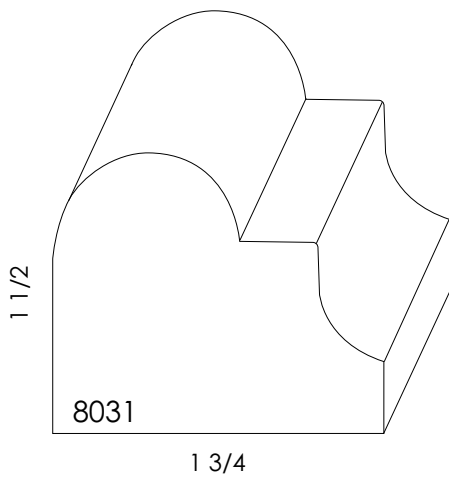
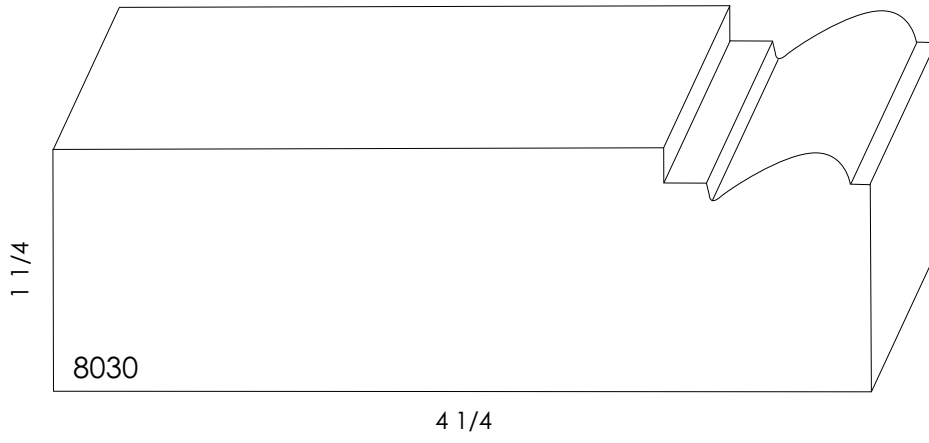
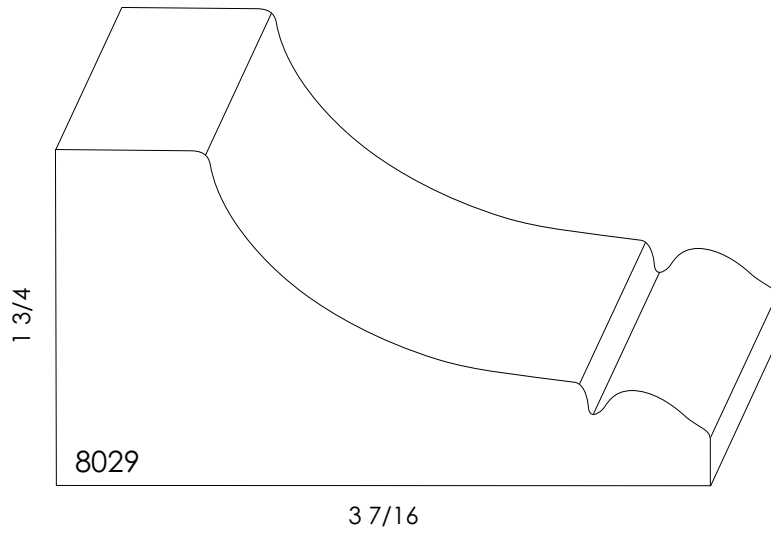

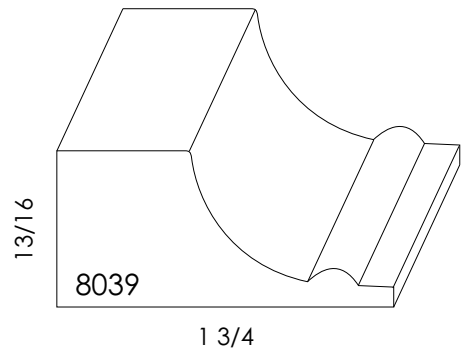
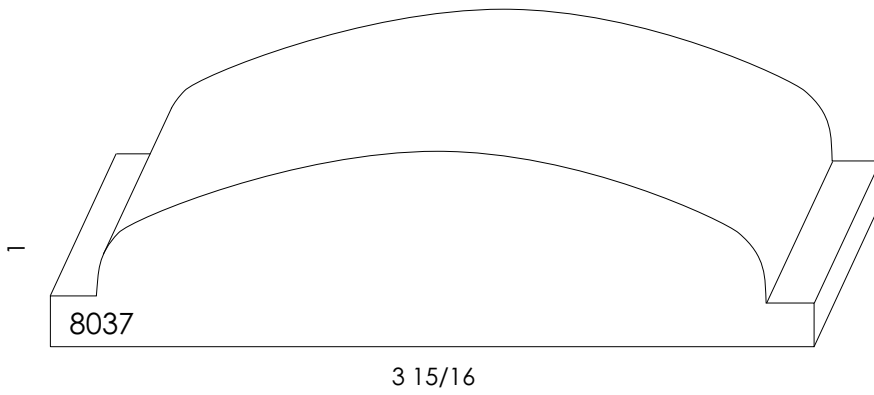
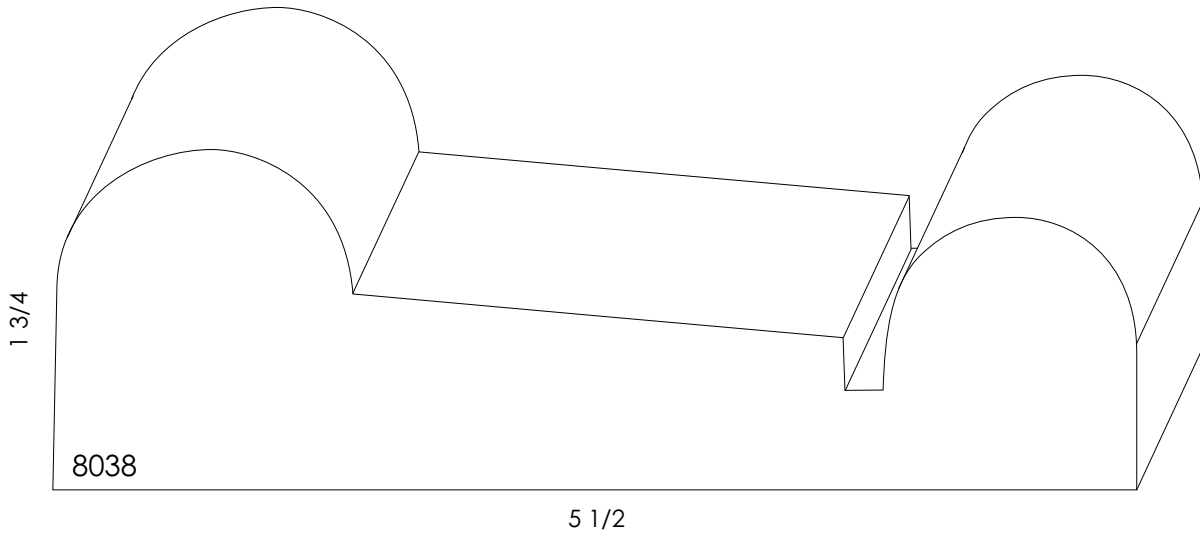
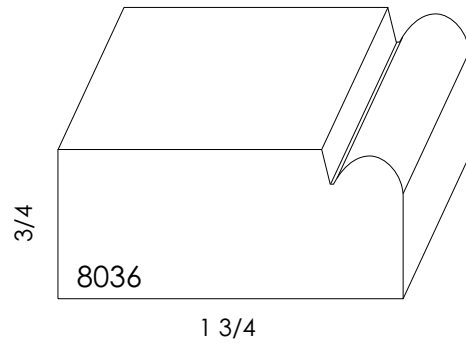
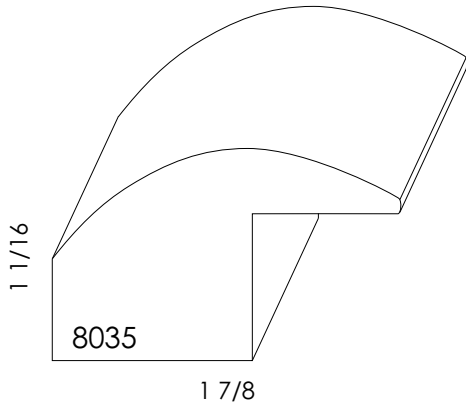
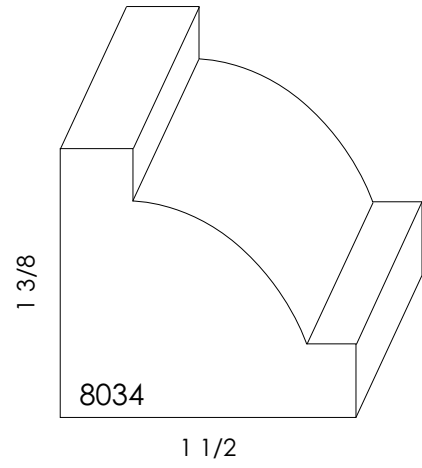
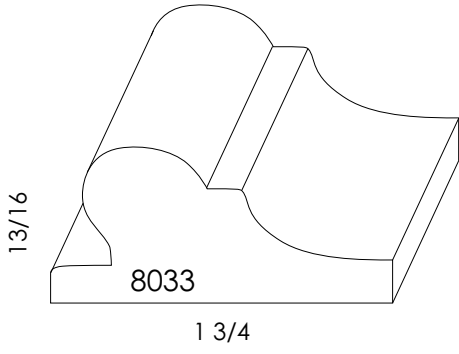

Miscellaneous

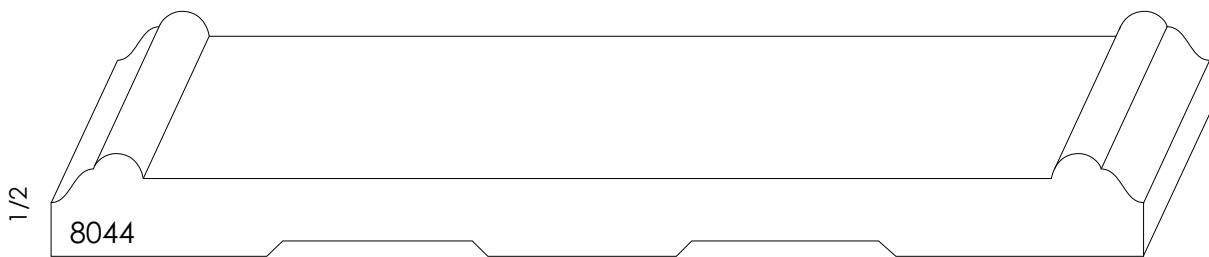
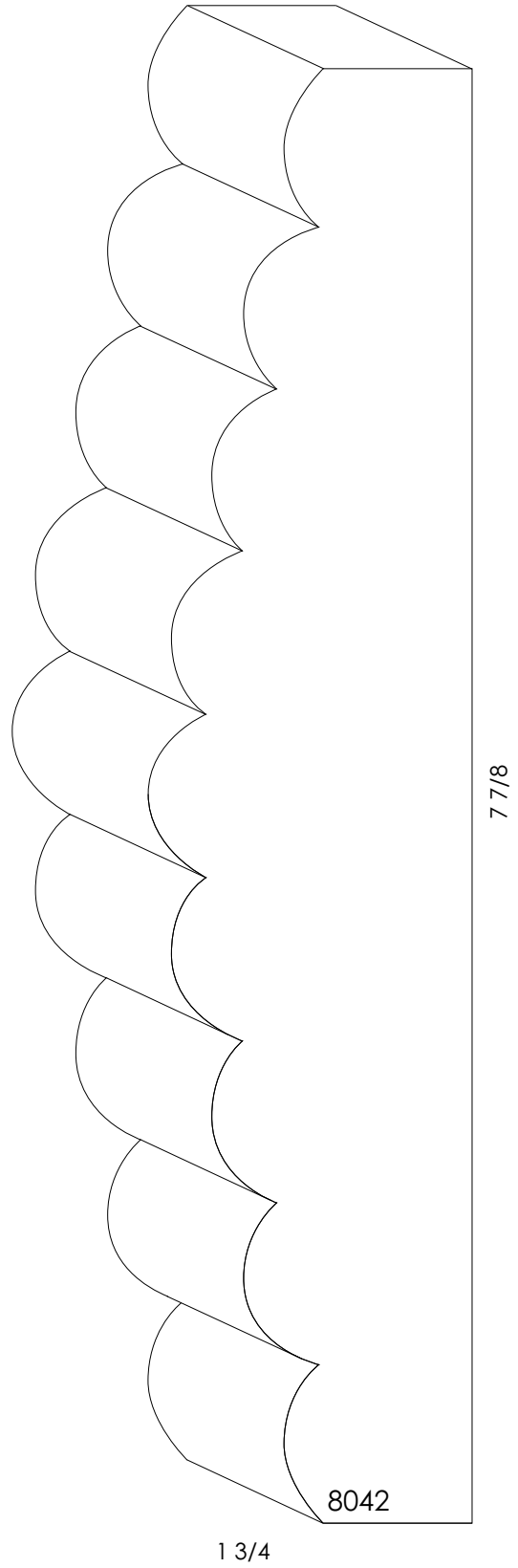
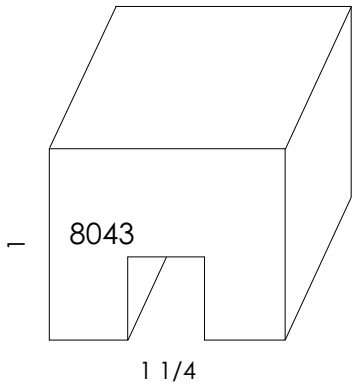
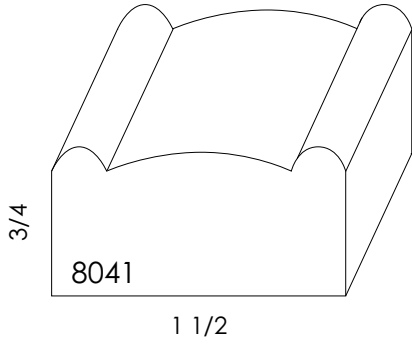
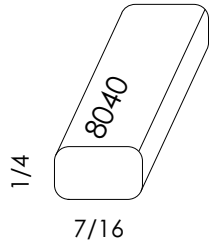

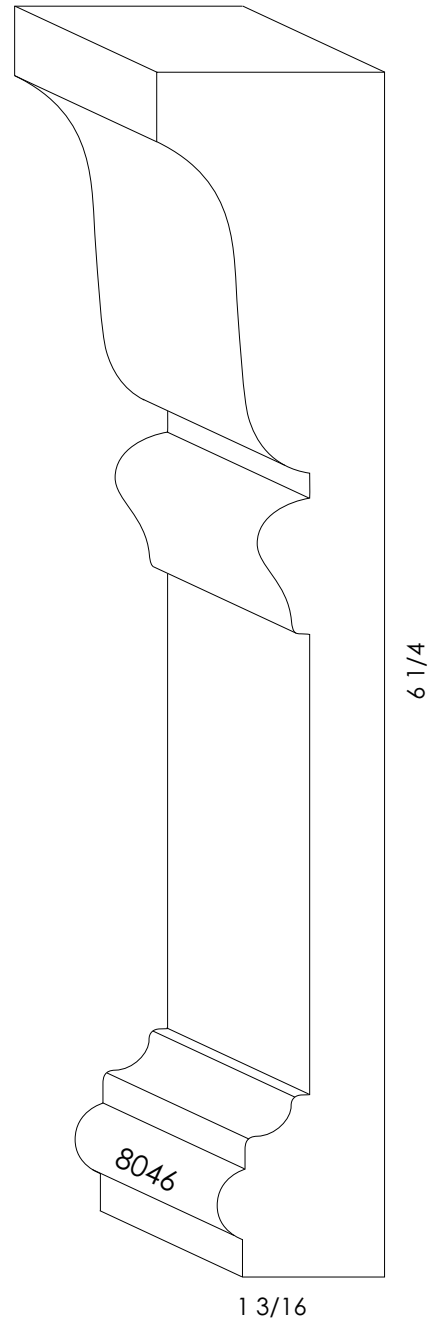
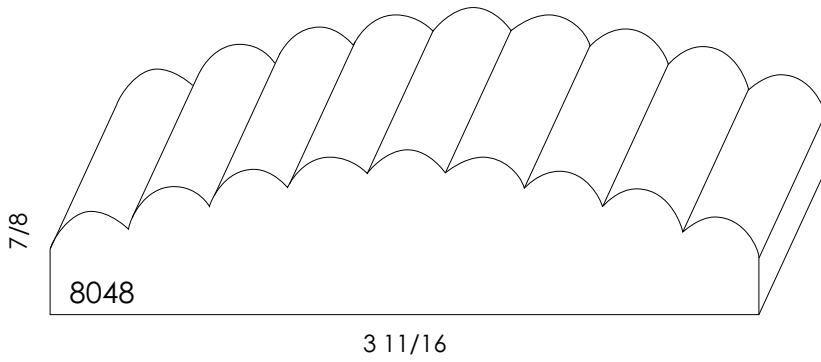
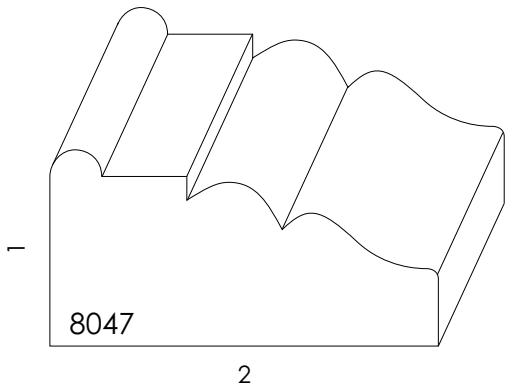
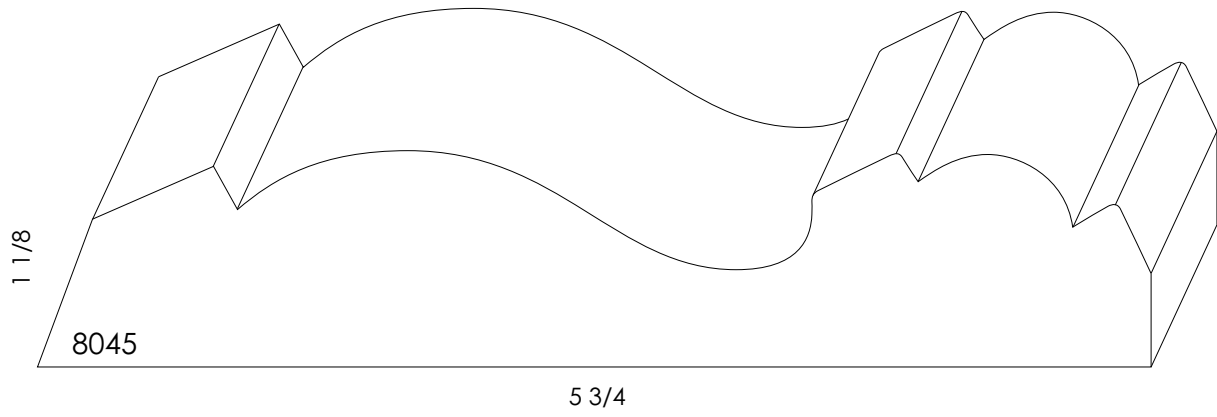

Miscellaneous

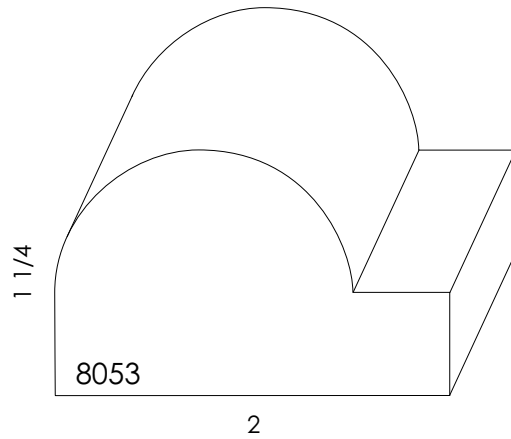
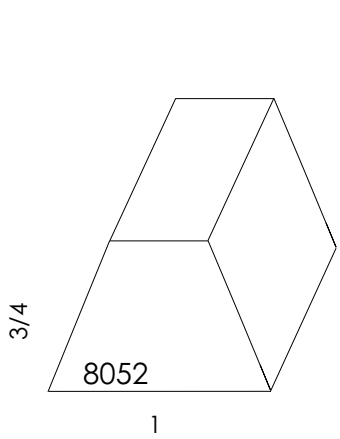
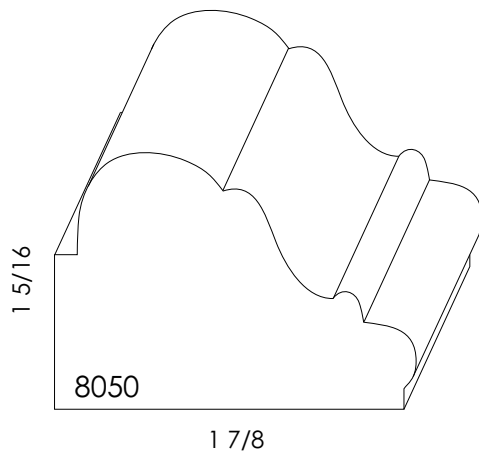
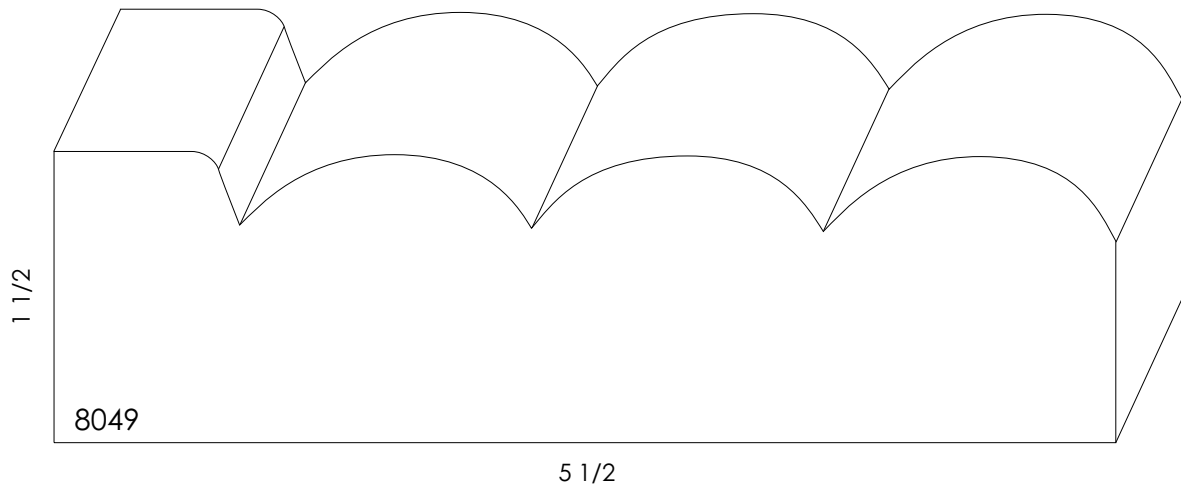

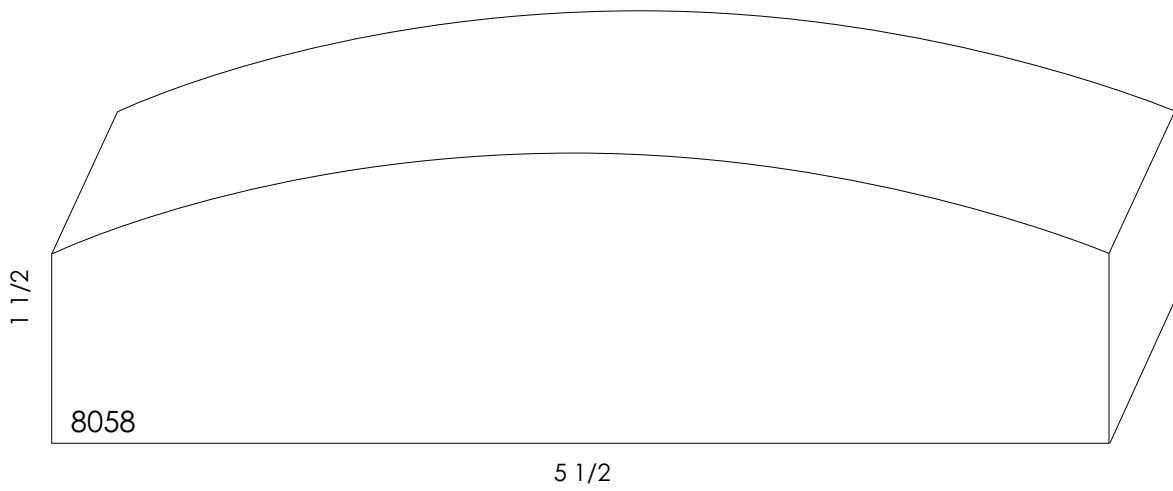
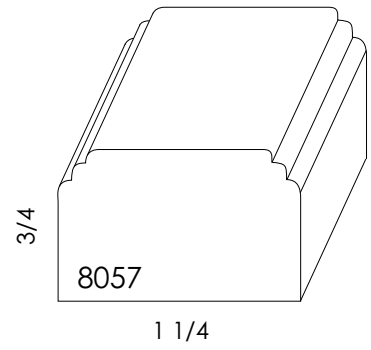
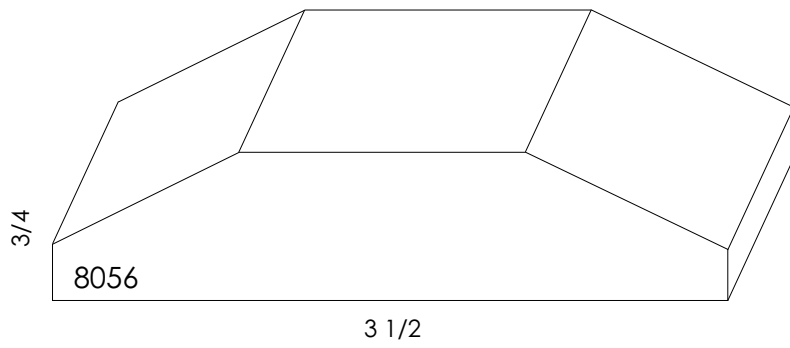
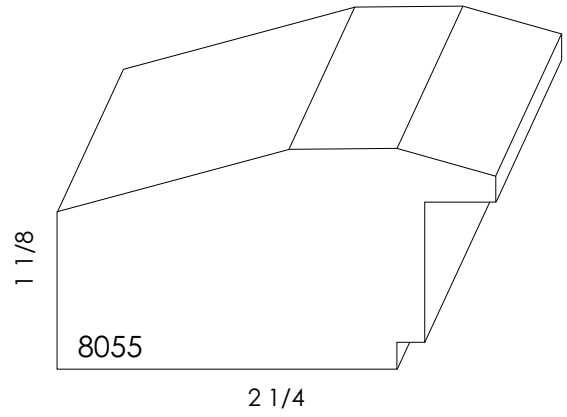

Miscellaneous

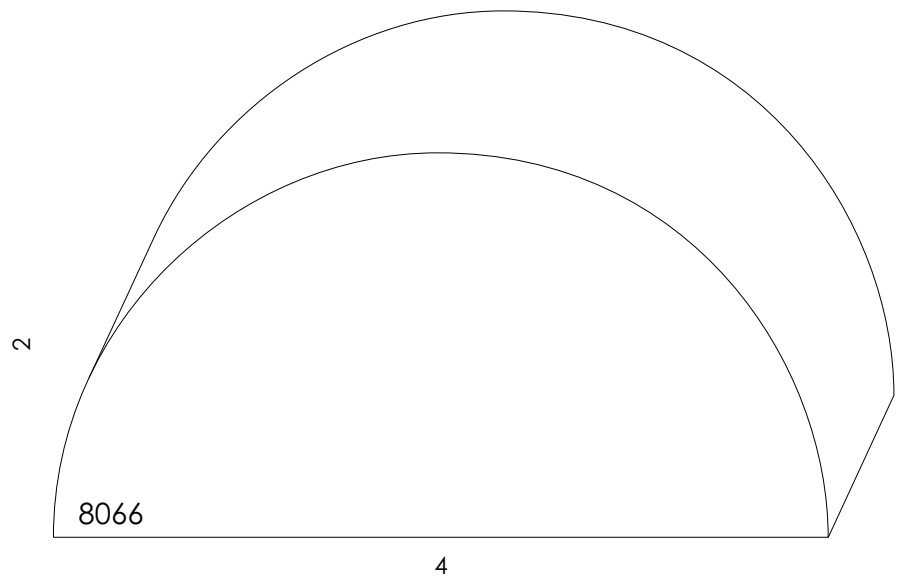
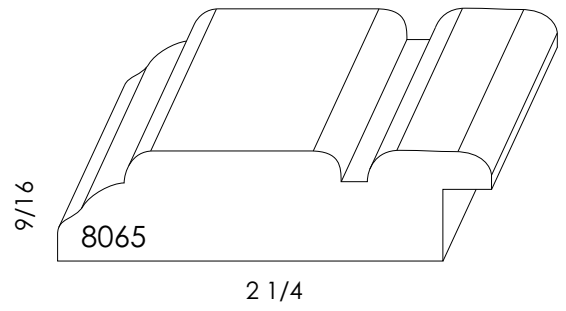
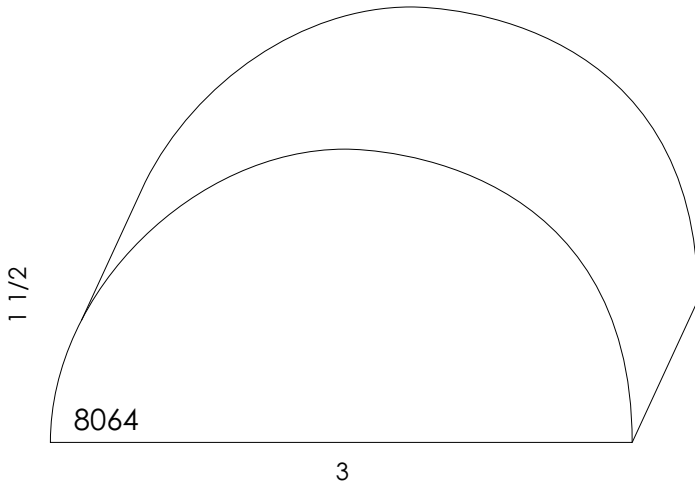
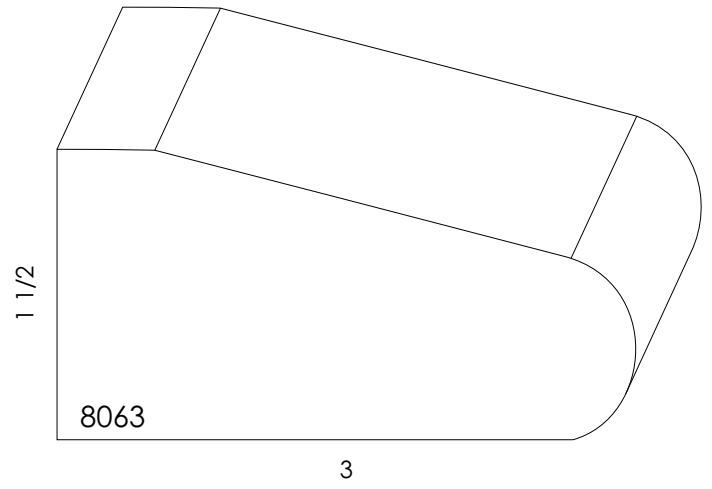
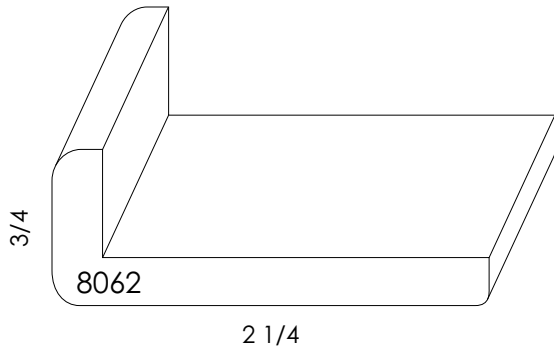
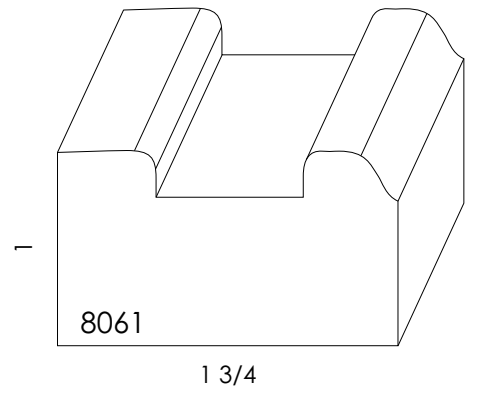
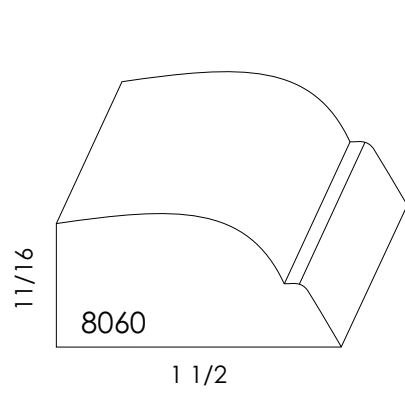
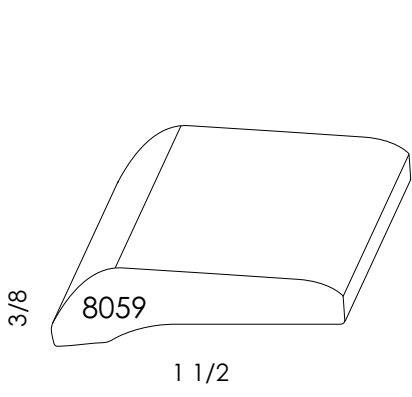

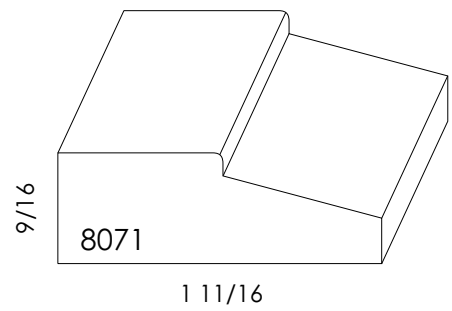
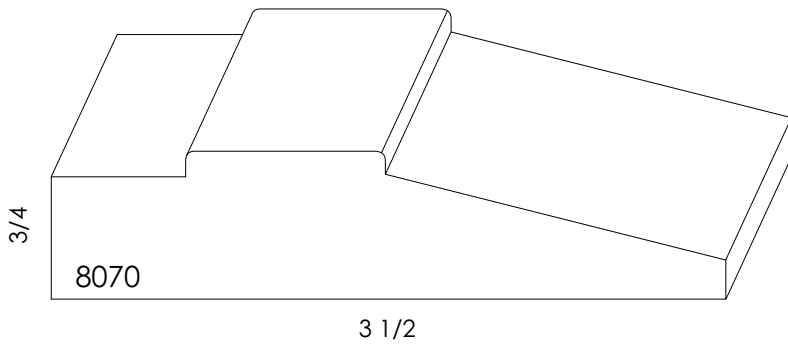
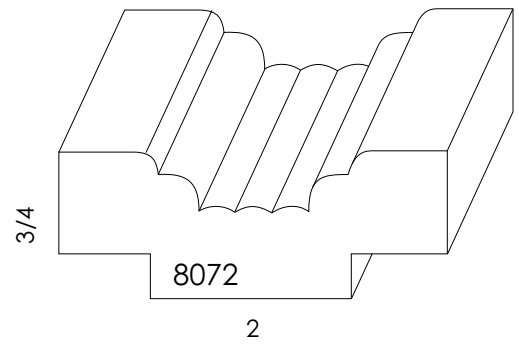
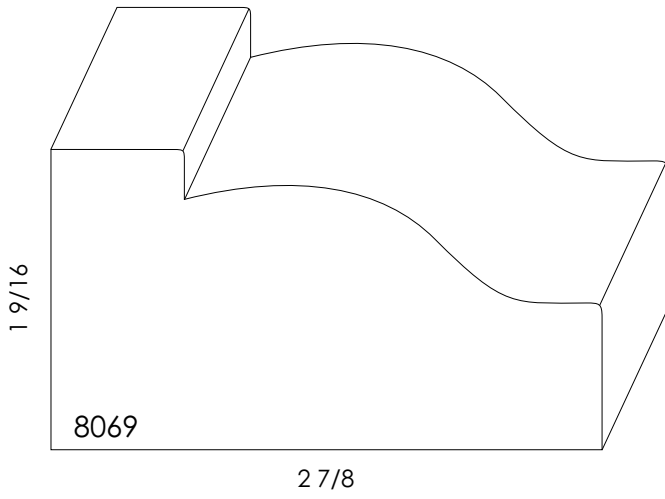
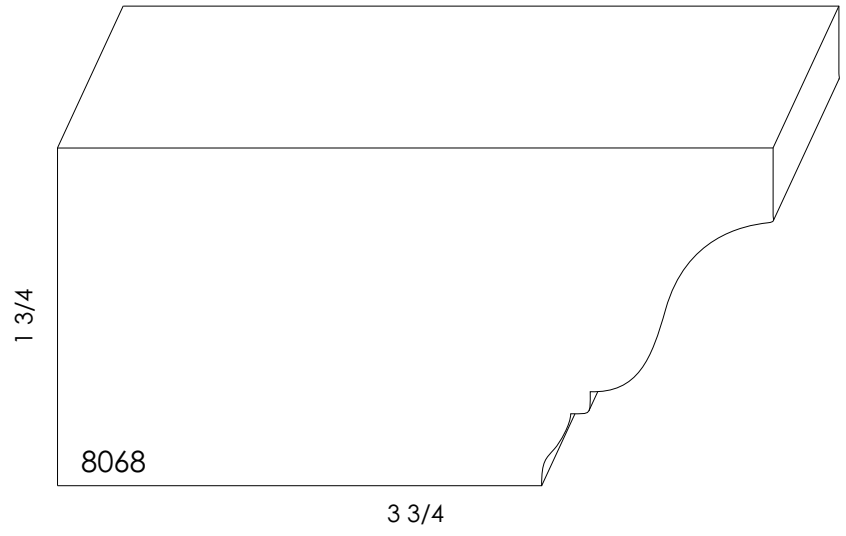
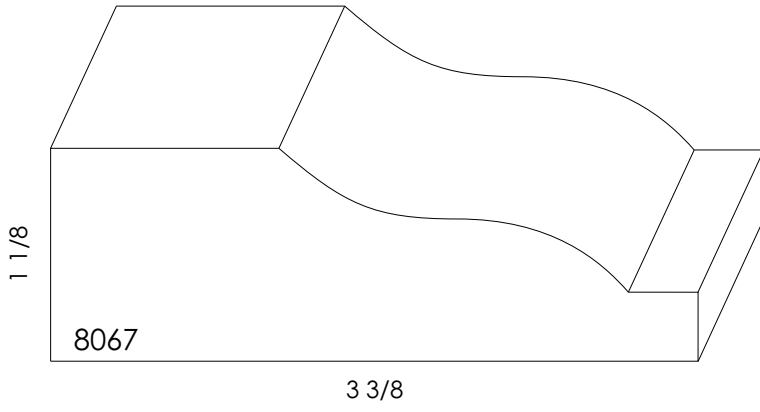

Miscellaneous

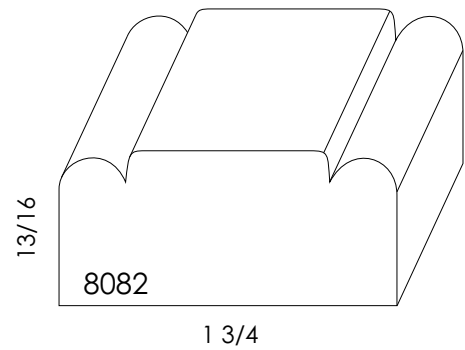
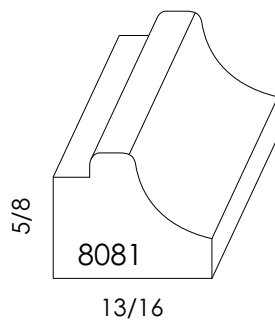
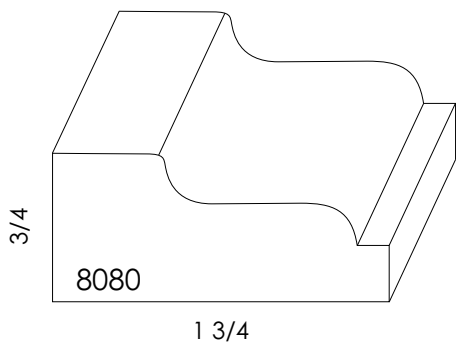
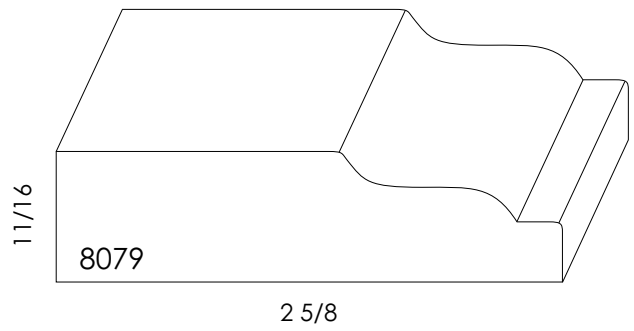
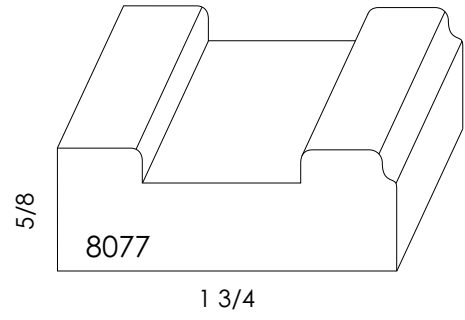
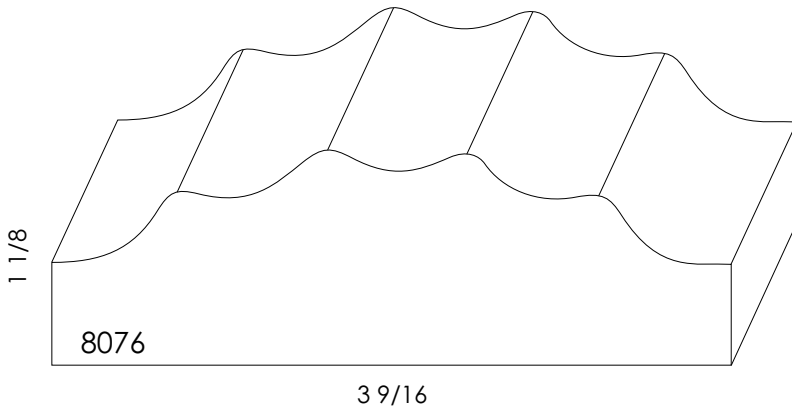
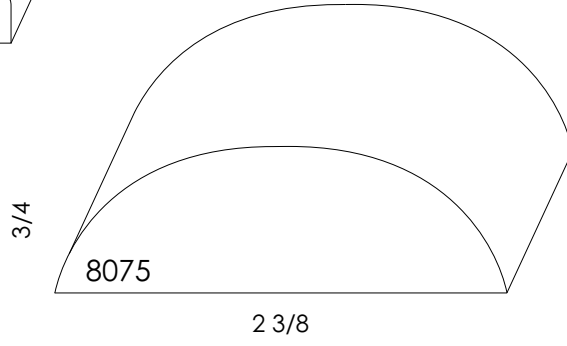
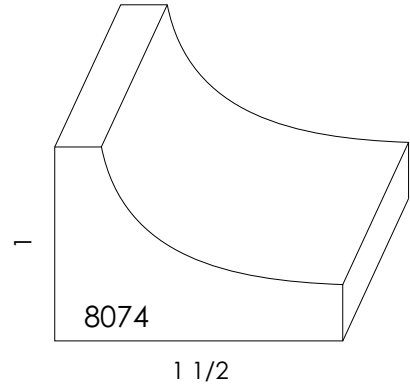
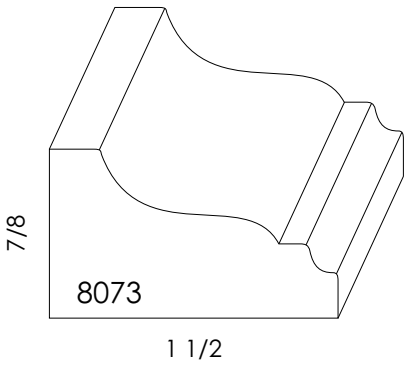

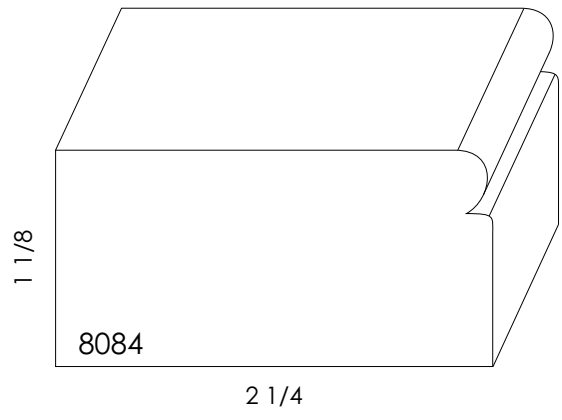
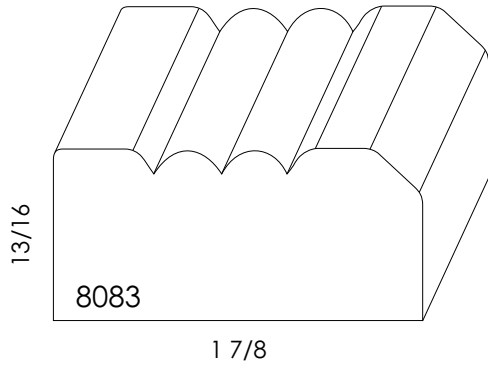

Miscellaneous

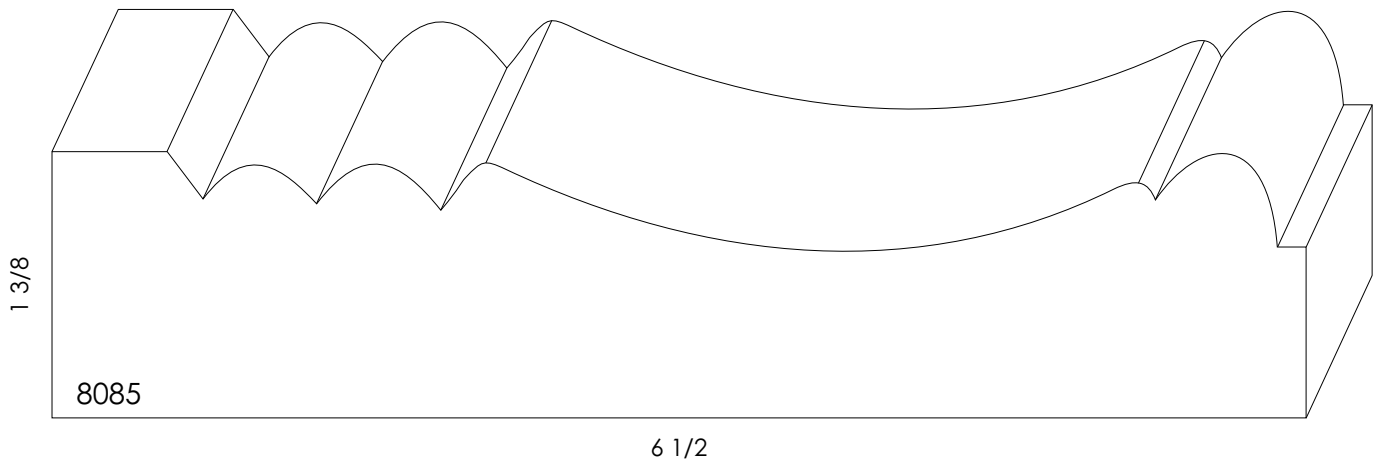

Plinth Block

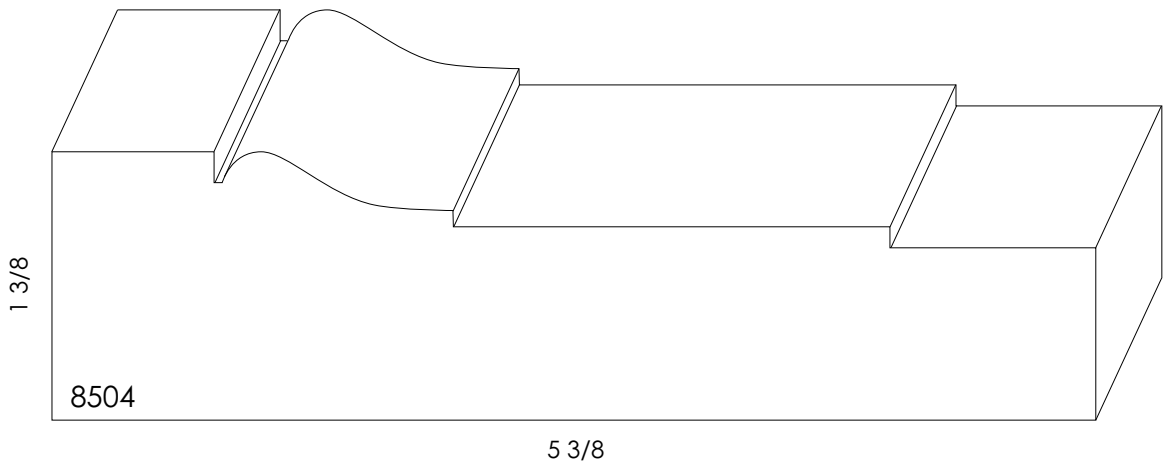
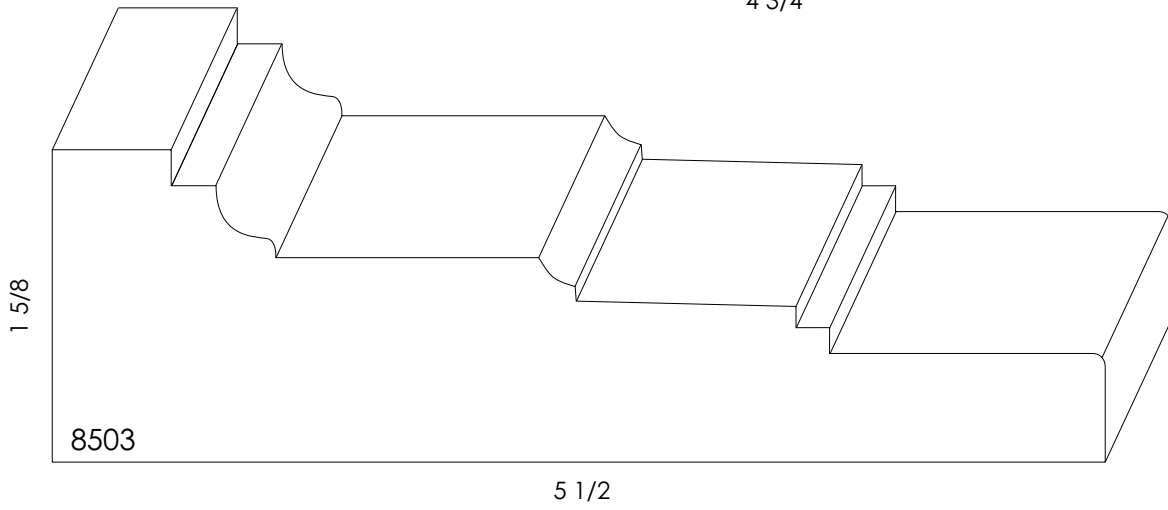
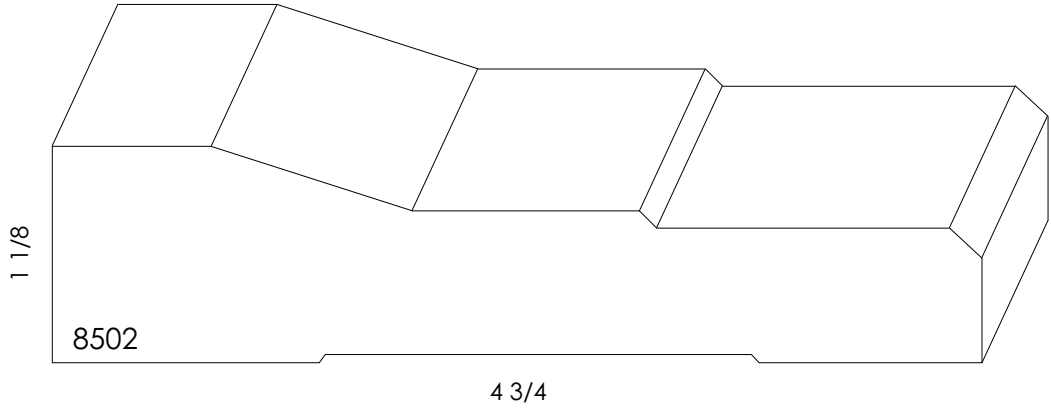
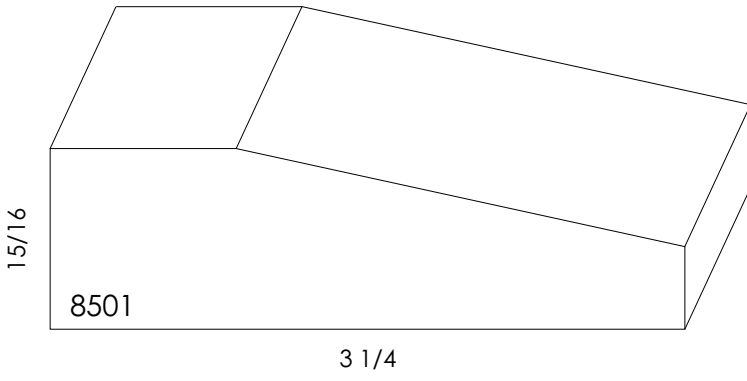

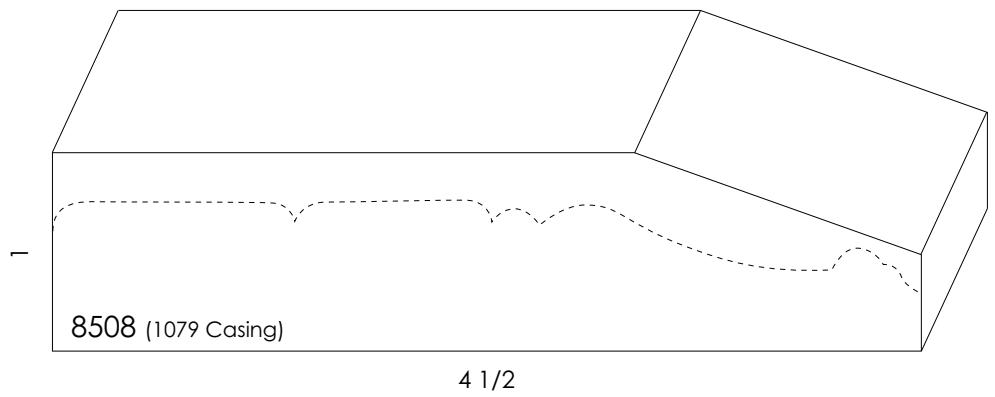
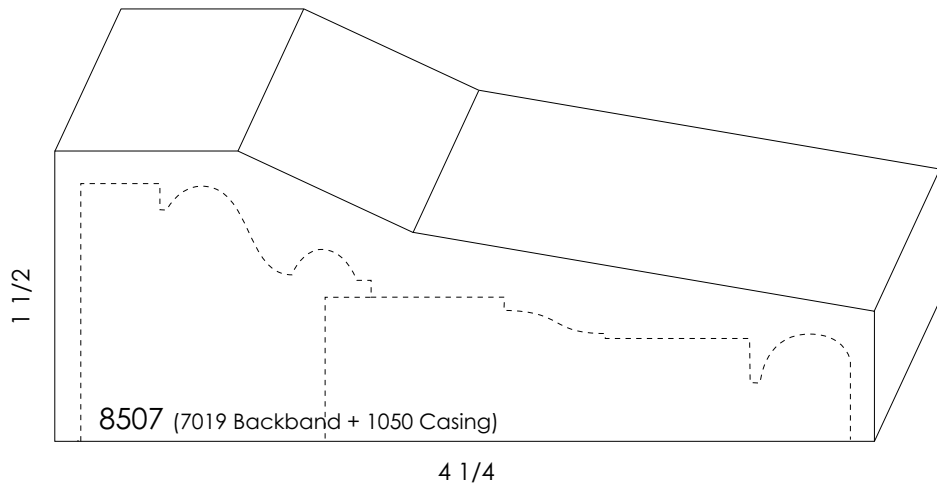
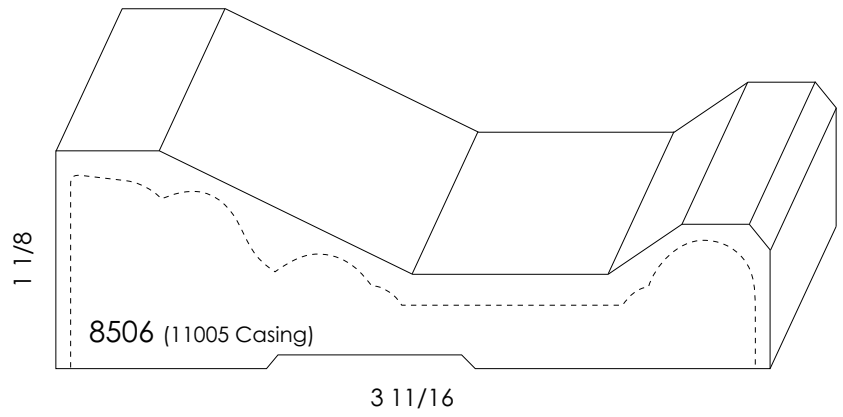
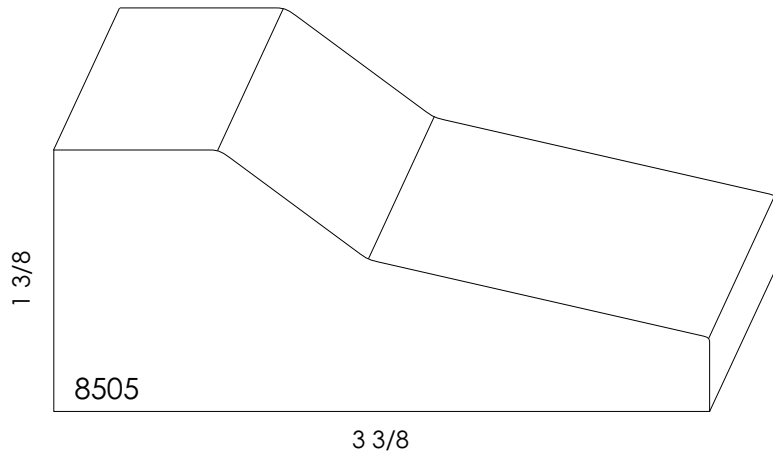

Plinth Block

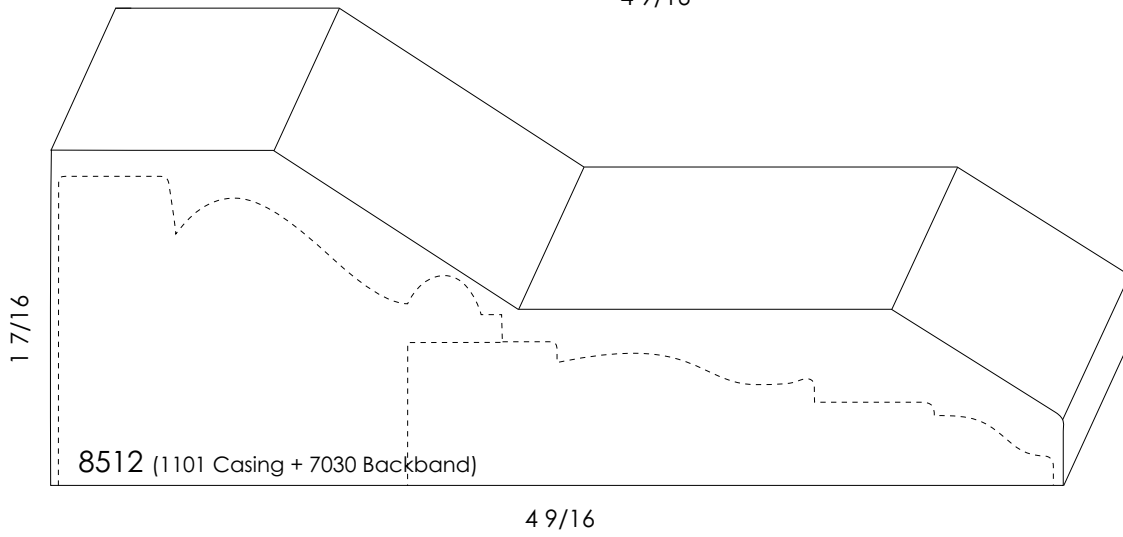
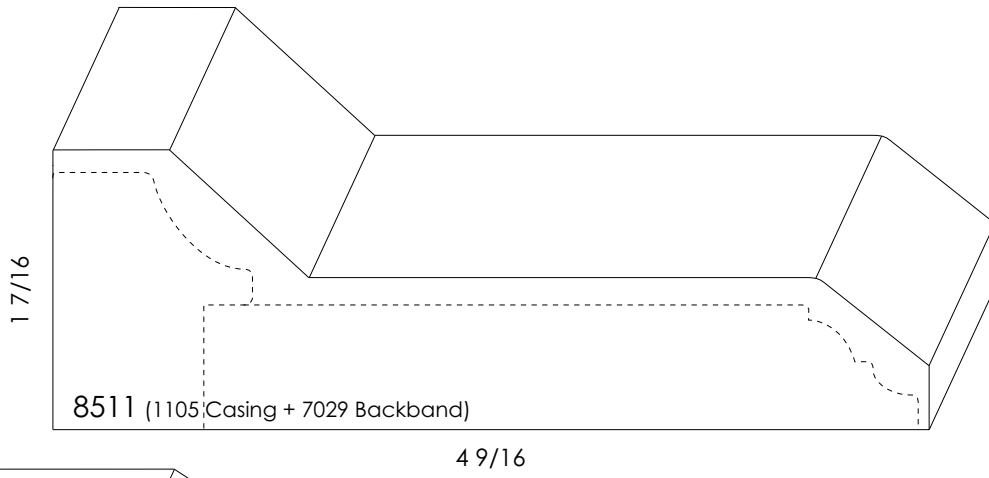
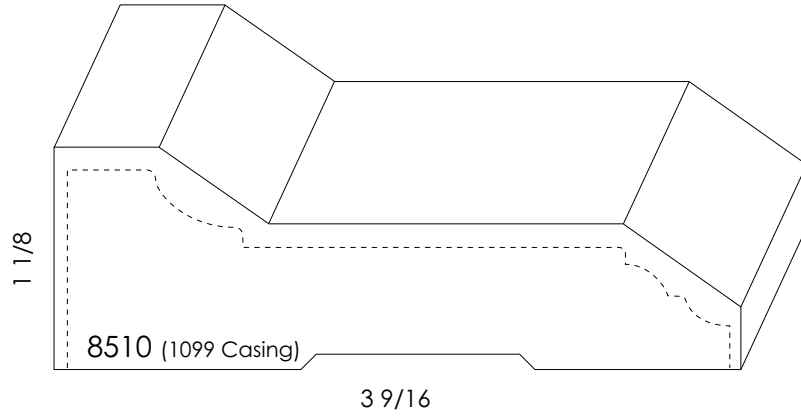
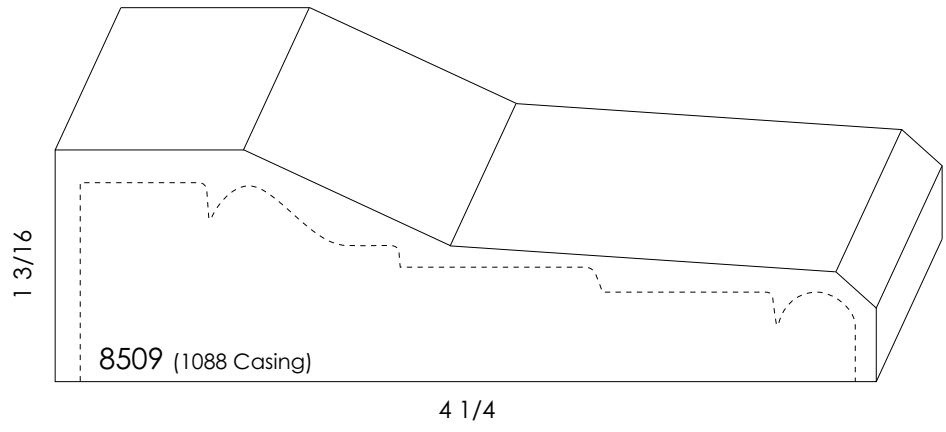

Pinth Block

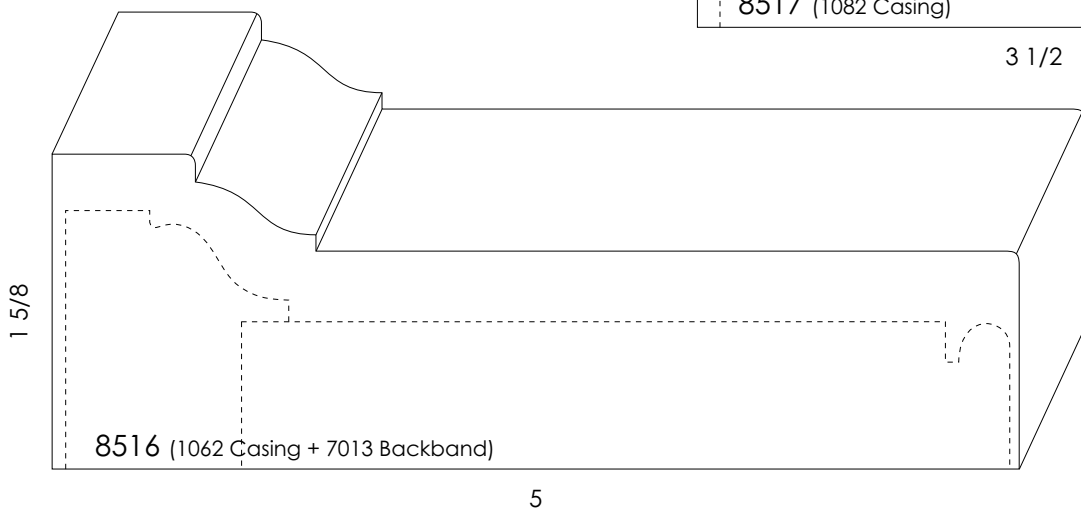
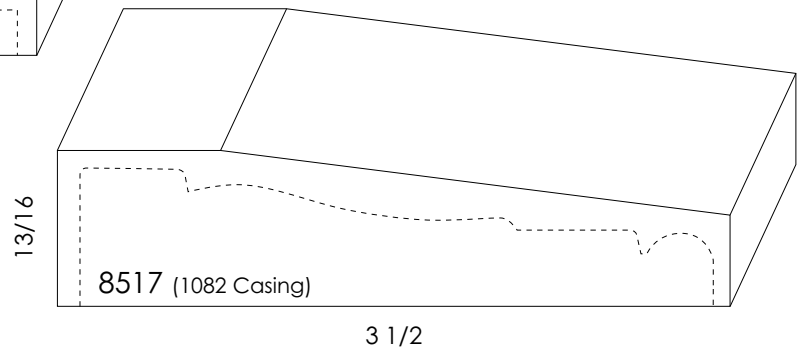
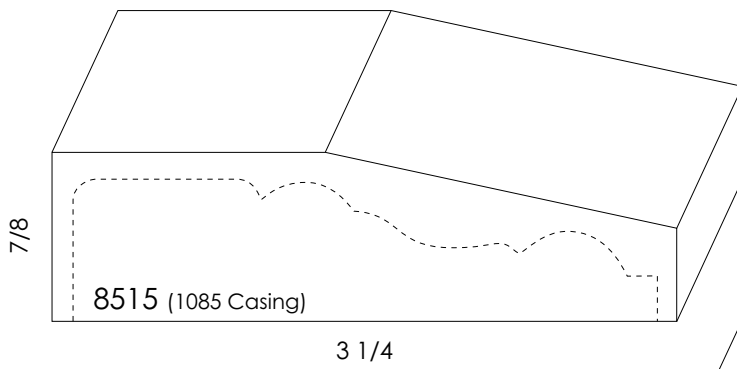
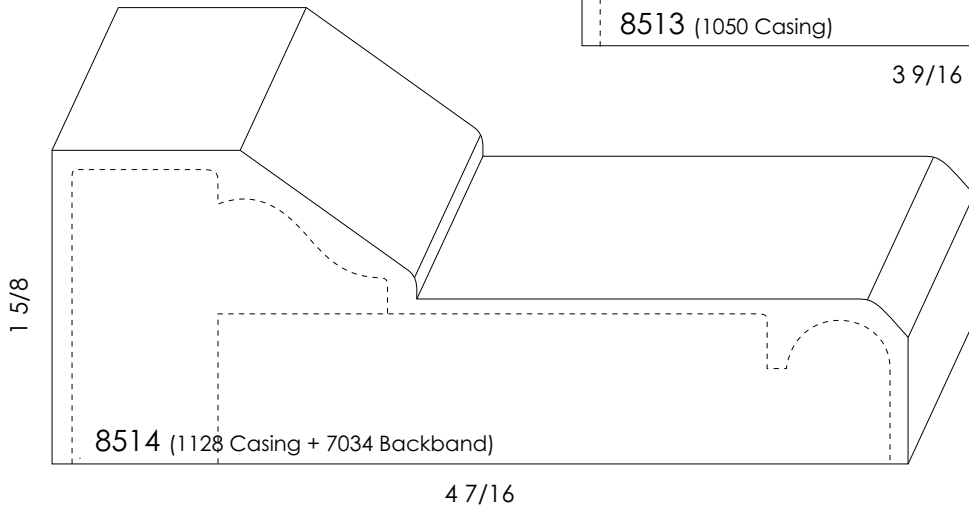
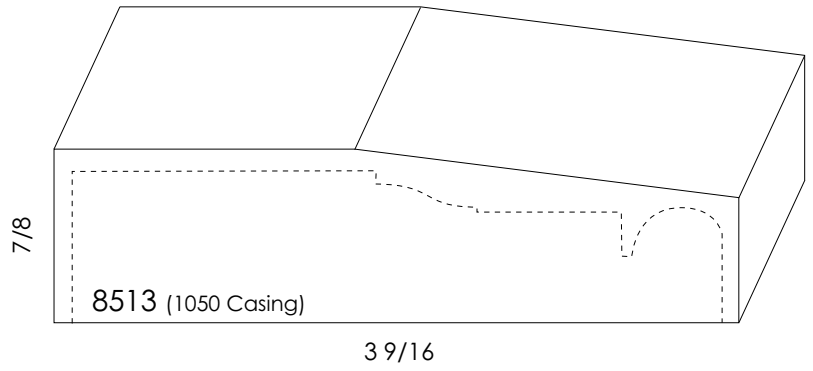

Plinth Block

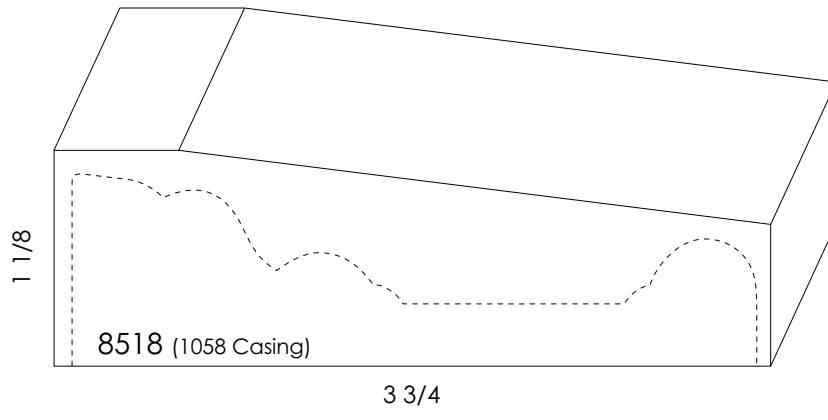

Bar Rail

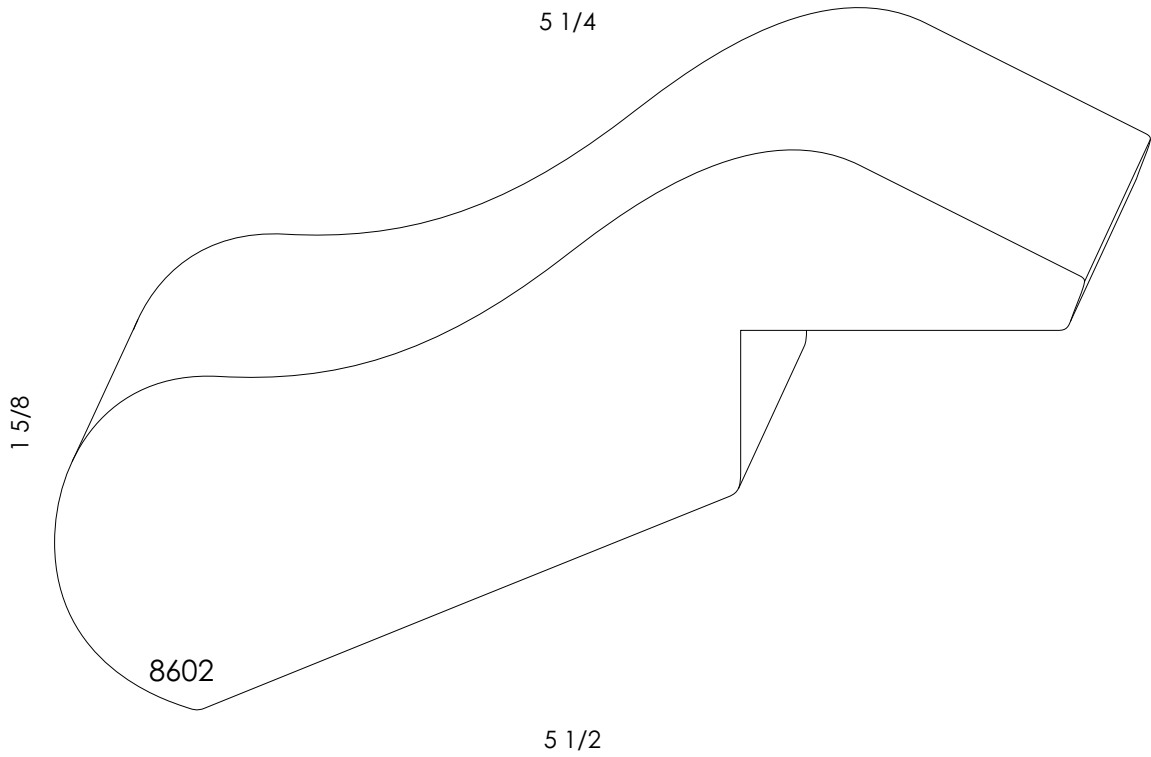
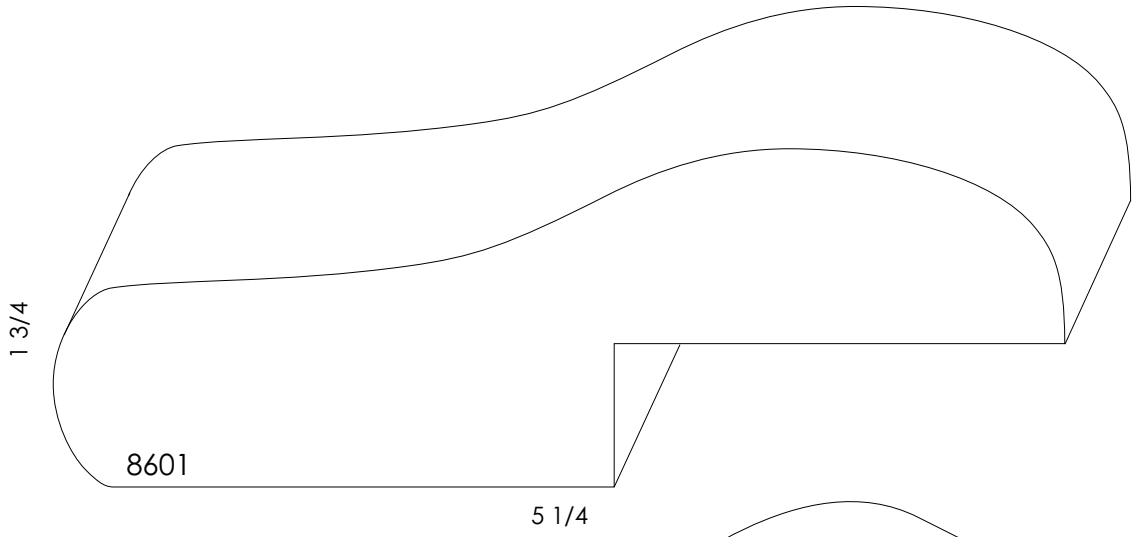

Tongue and Groove

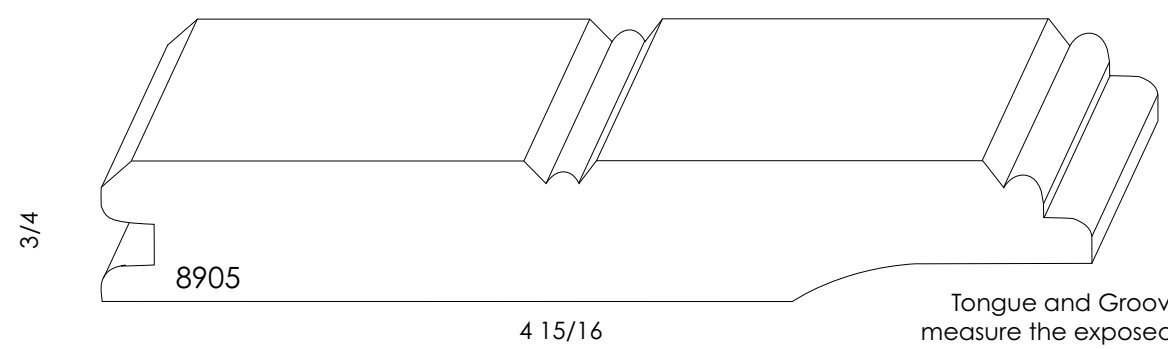
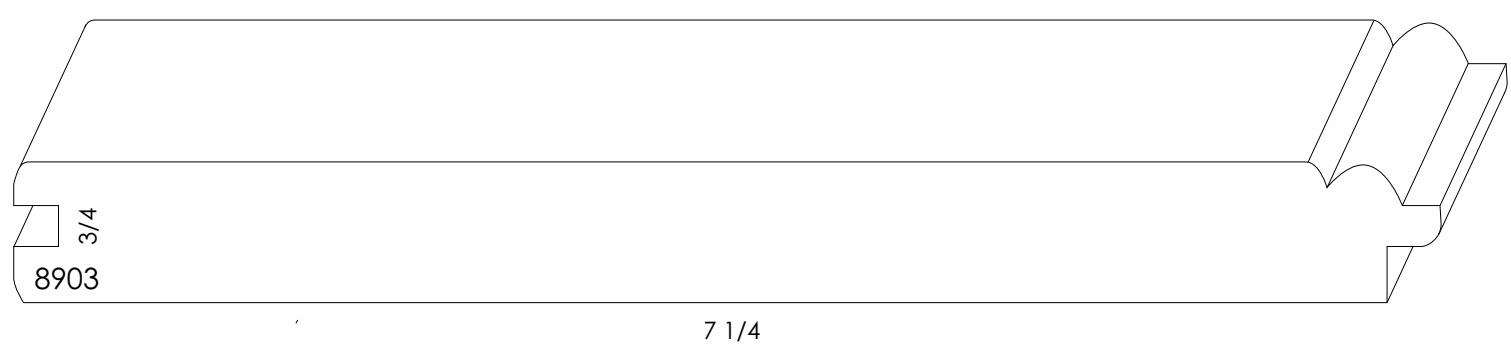
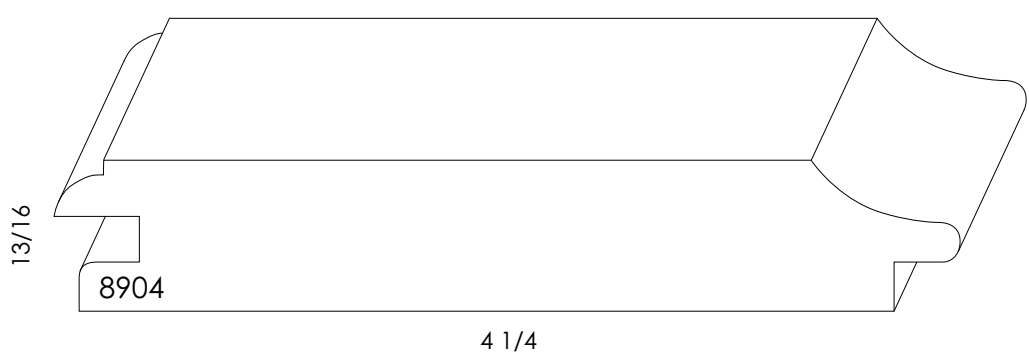
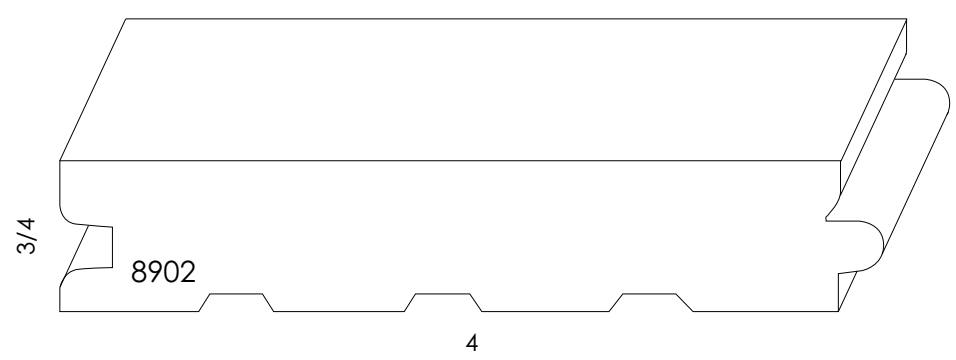
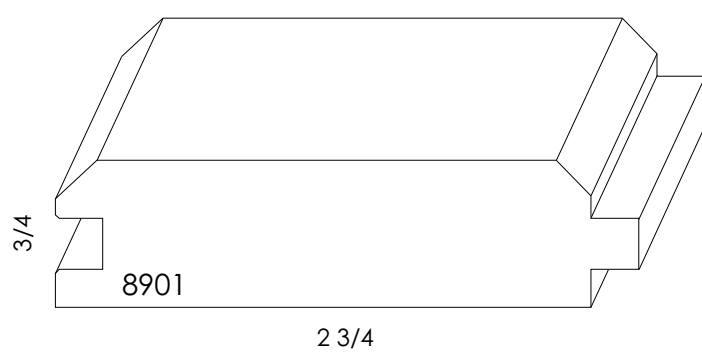

Tongue and Groove widths measure the exposed face only.

Tongue and Groove

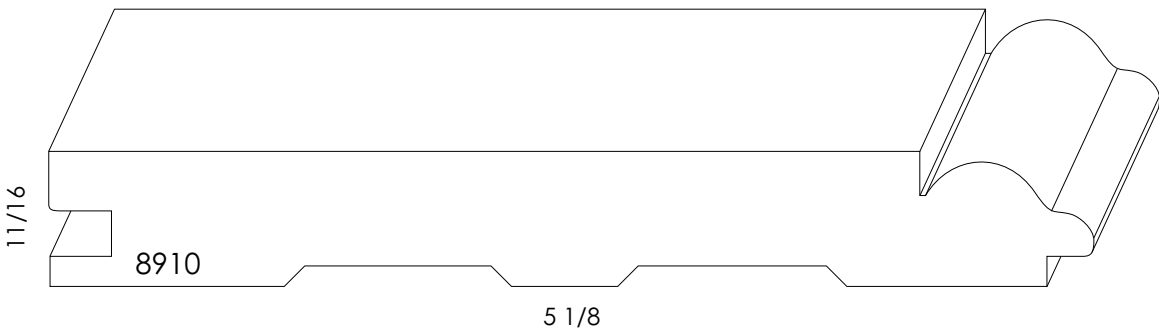
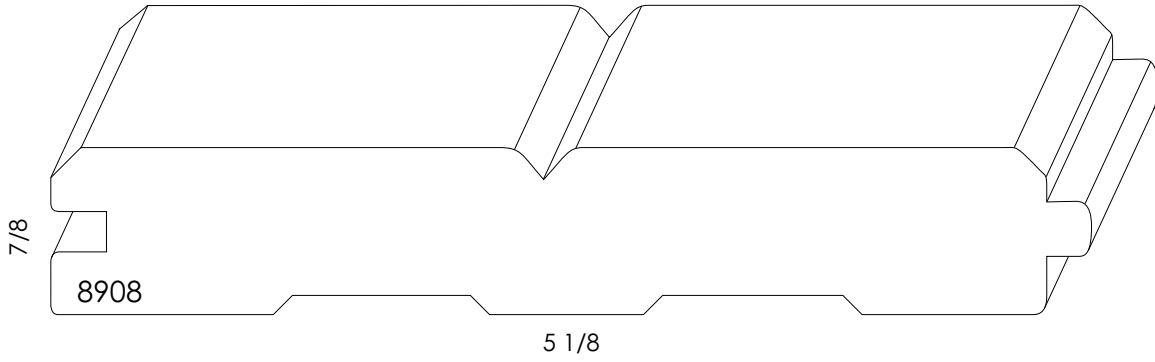
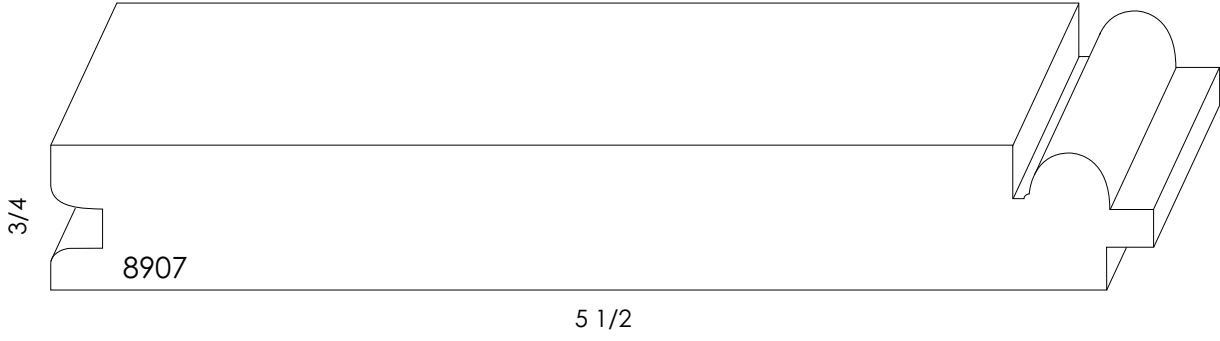
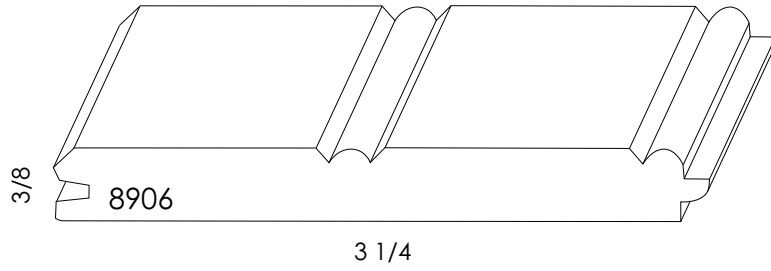

Tongue and Groove widths
measure the exposed face only.

Tongue and Groove

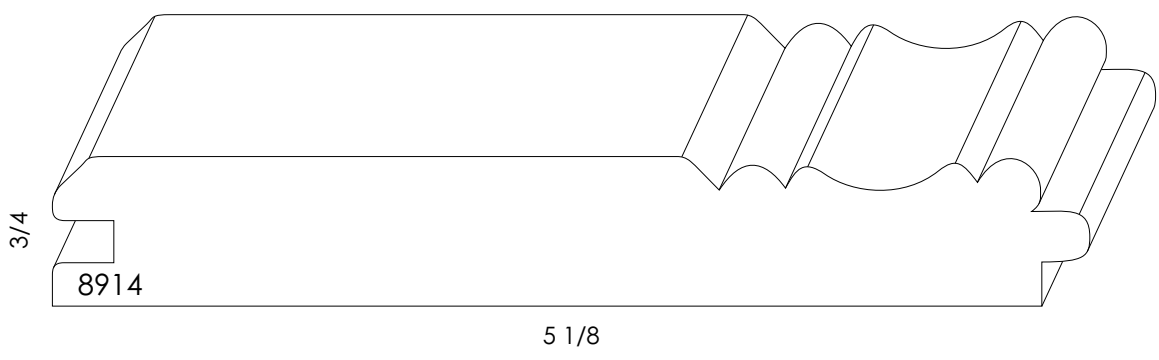
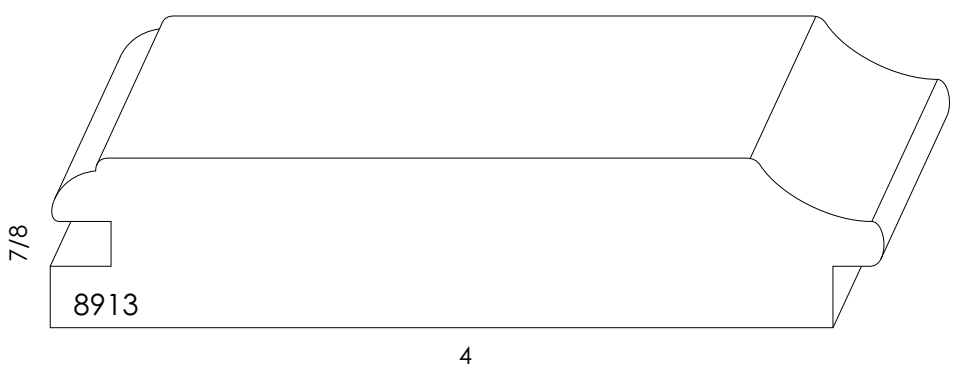
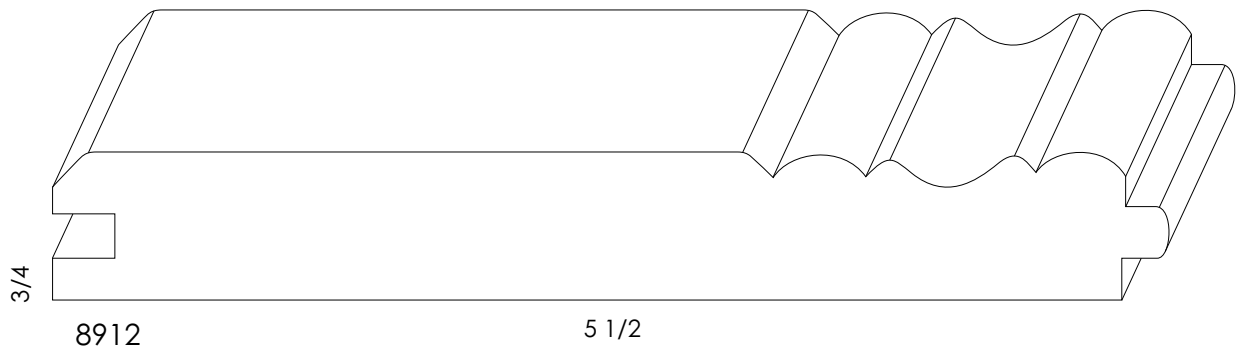
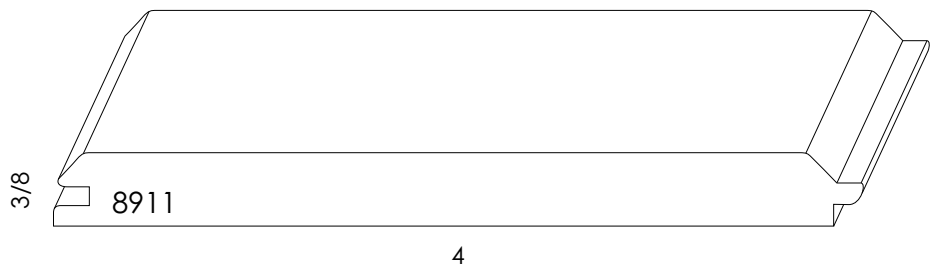

Tongue and Groove widths
measure the exposed face only.

Window Sill

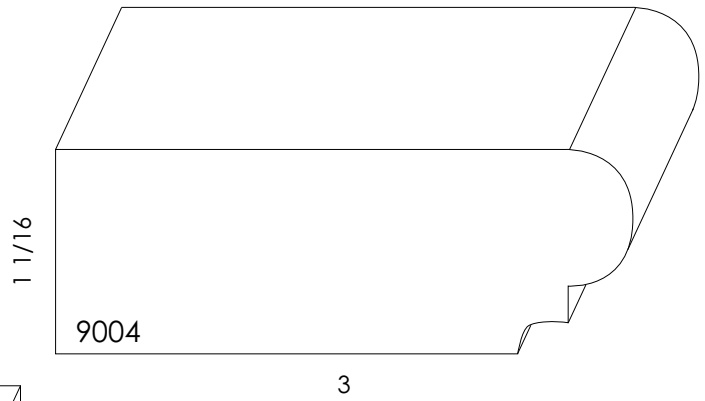
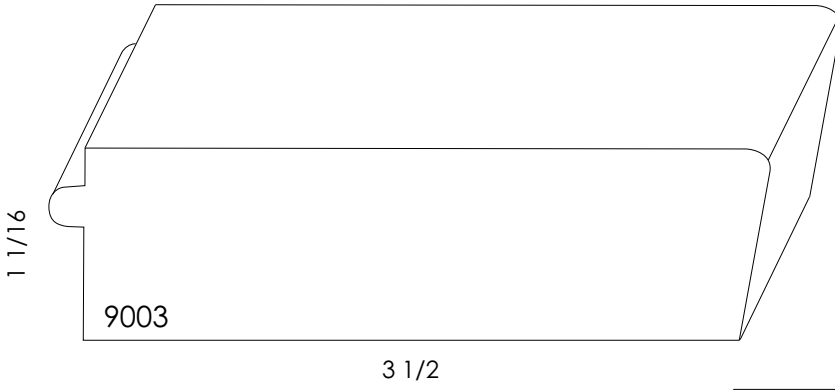
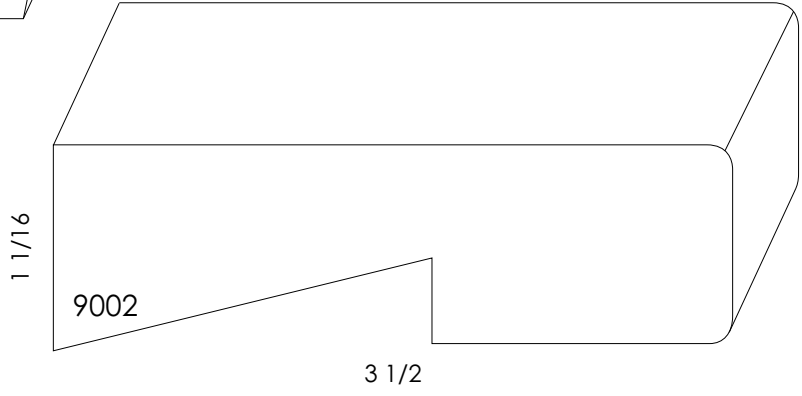
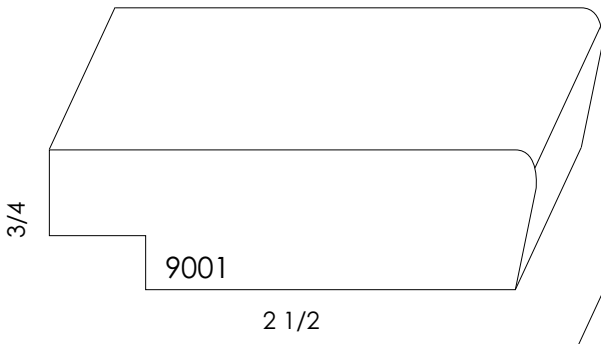

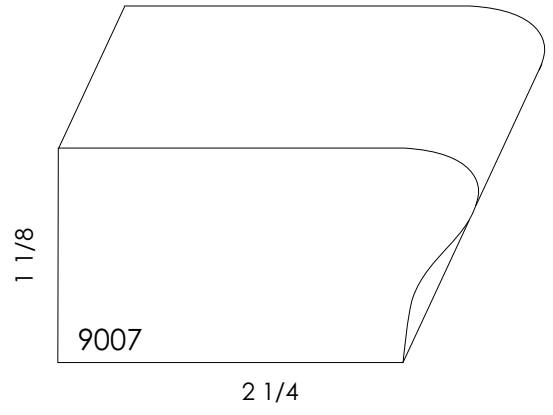
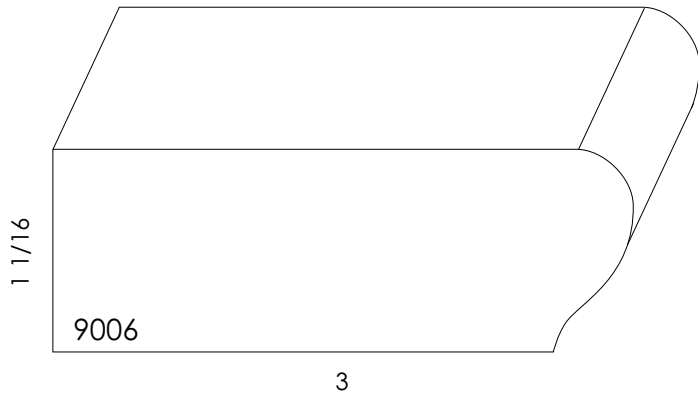

Window Sill

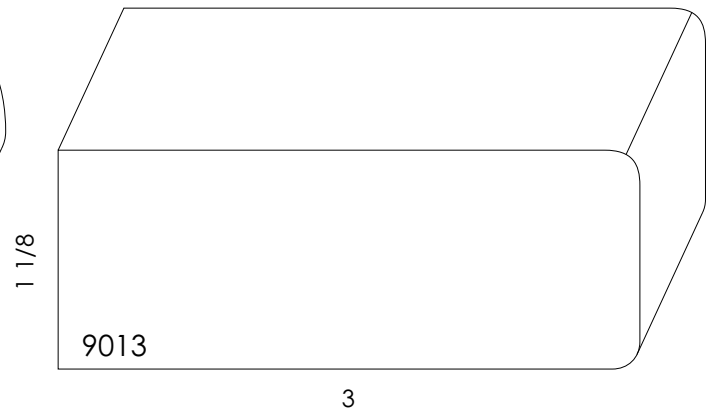
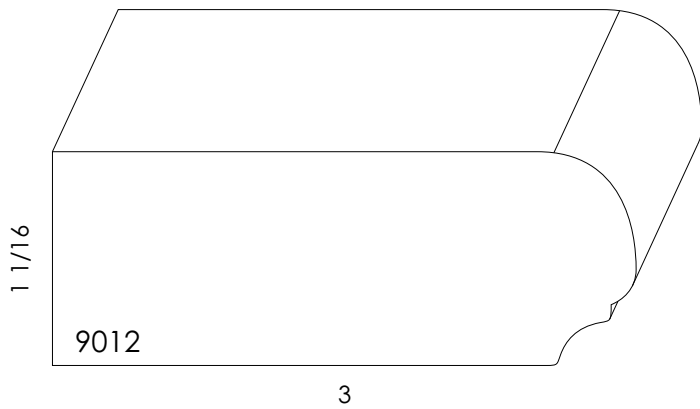
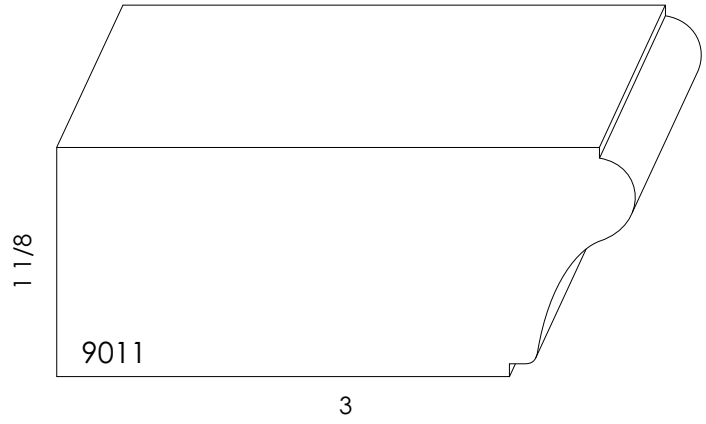
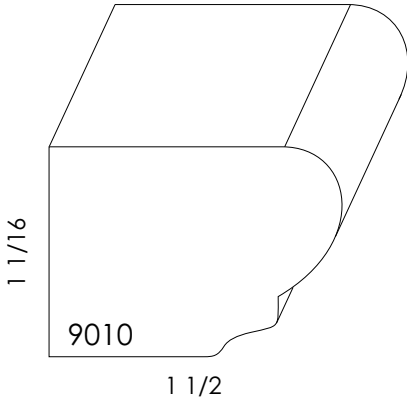
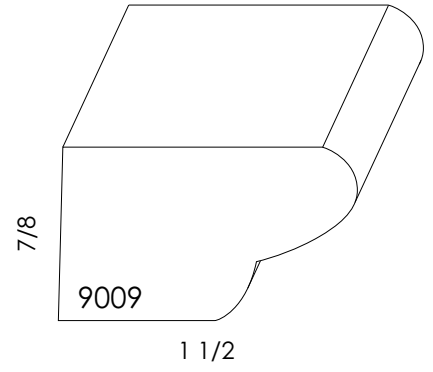
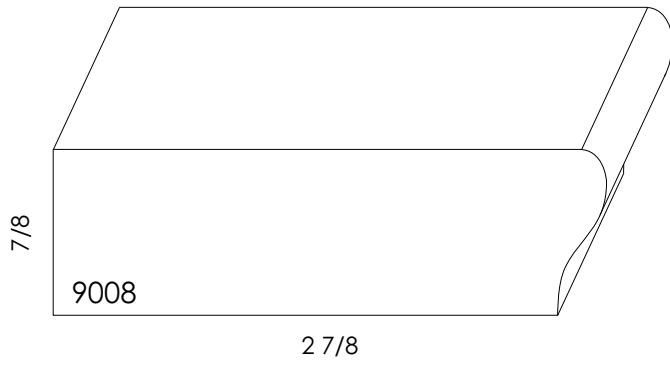

Nosing

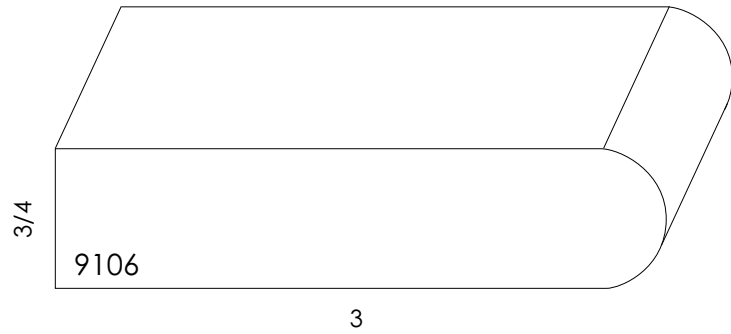
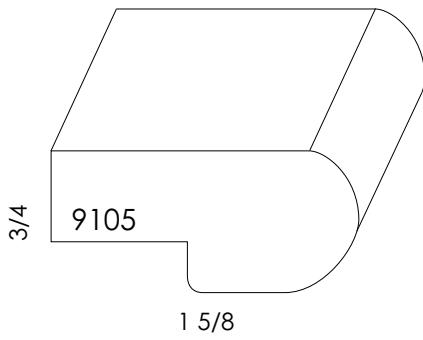
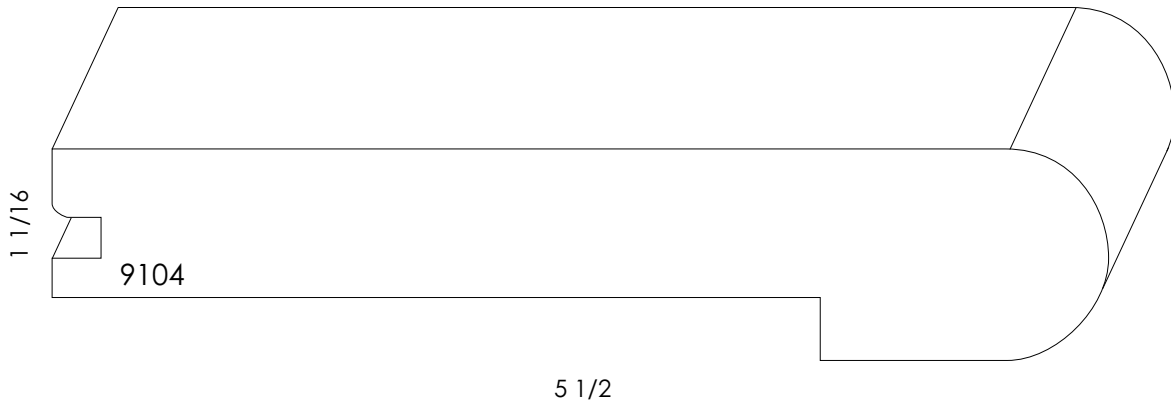
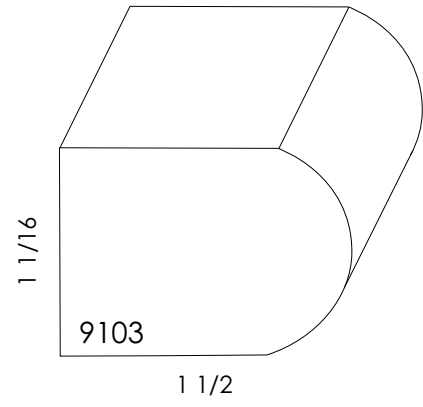
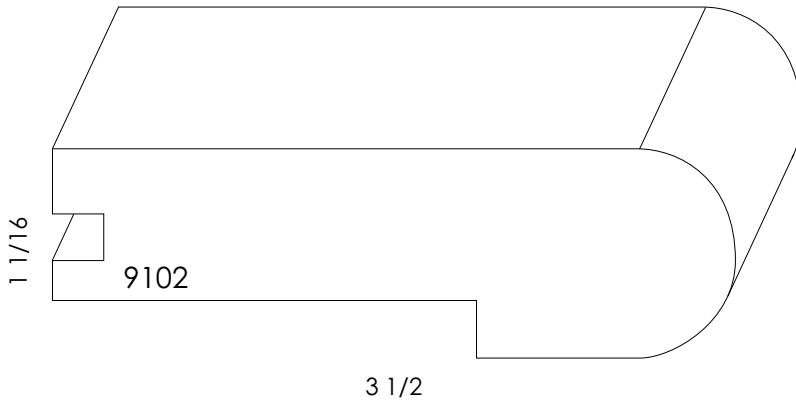
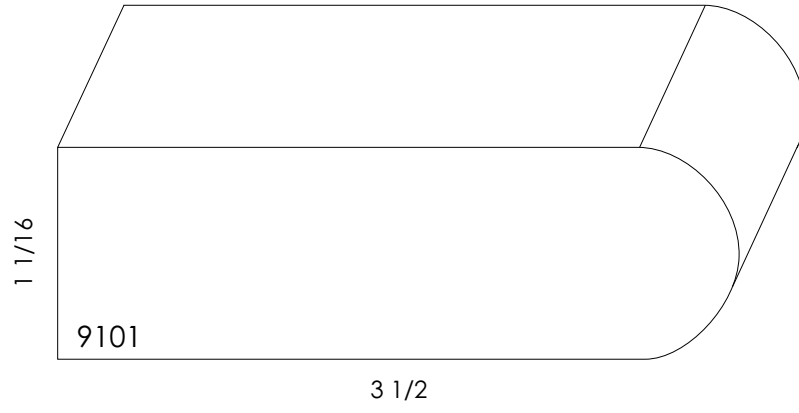

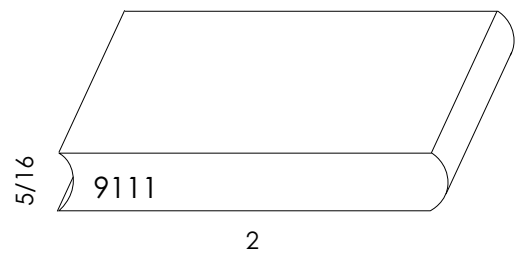
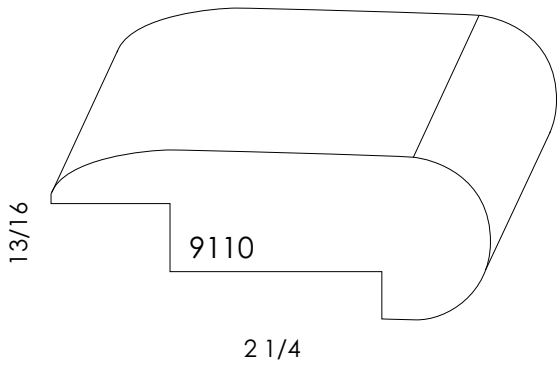
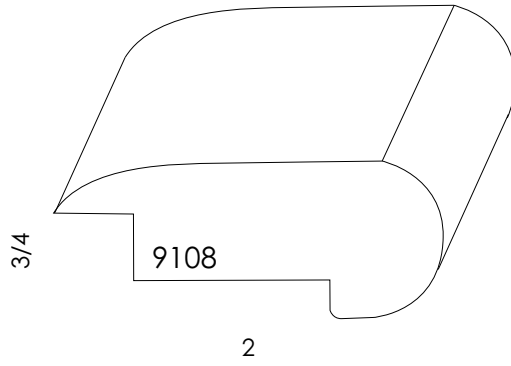
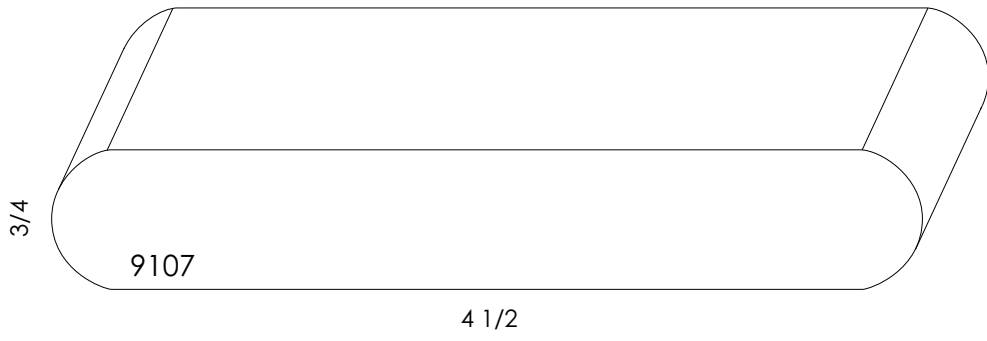

Nosing

Nosing

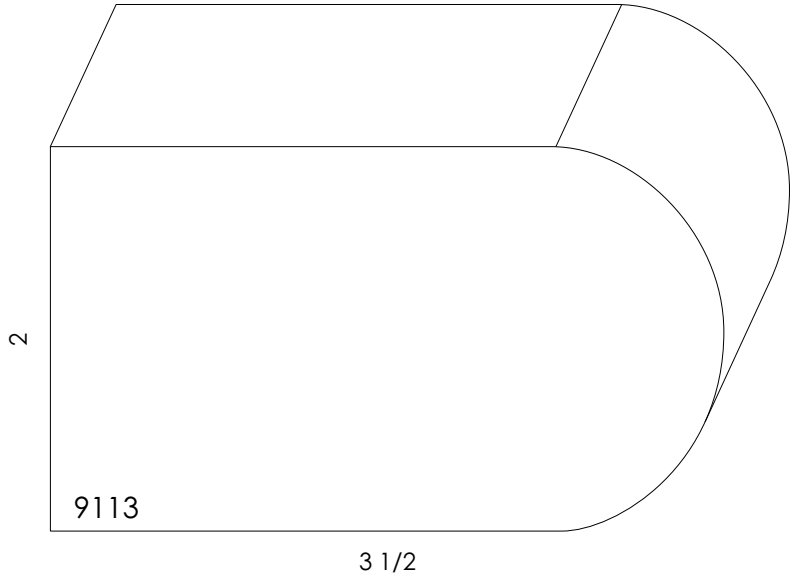
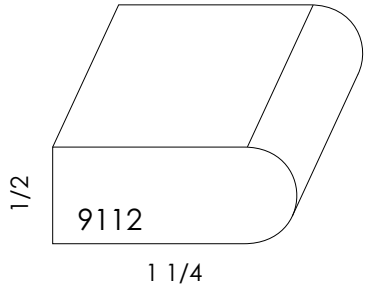

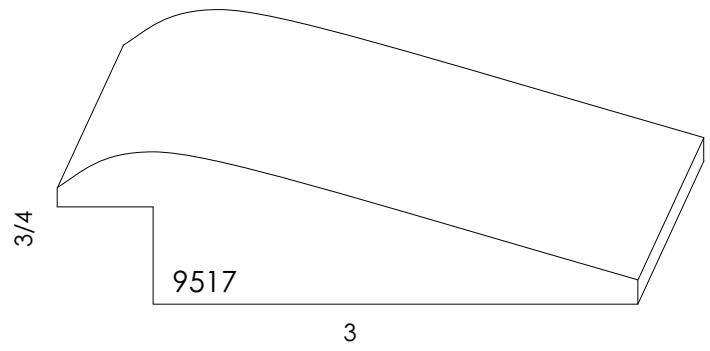
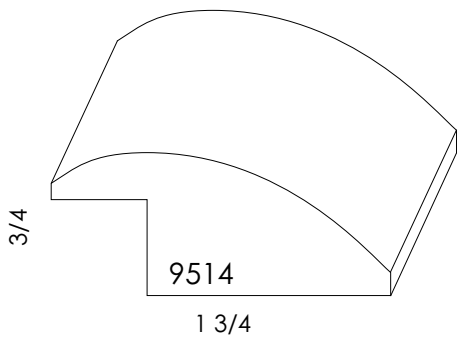
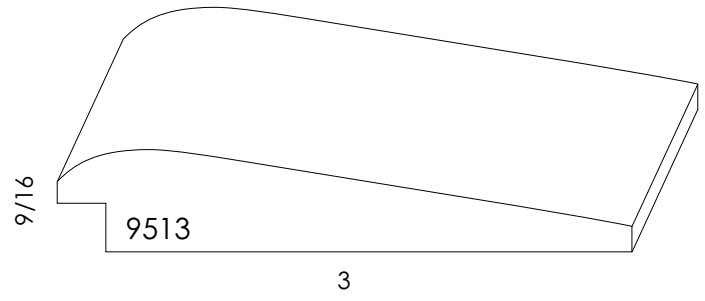
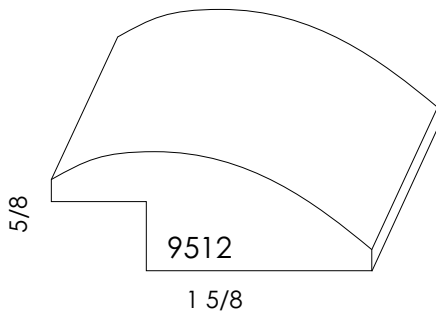
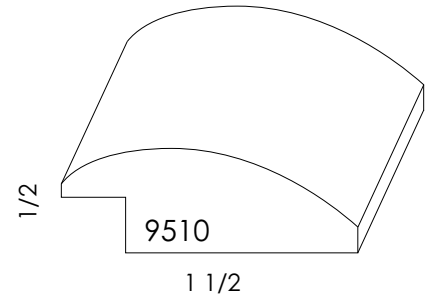
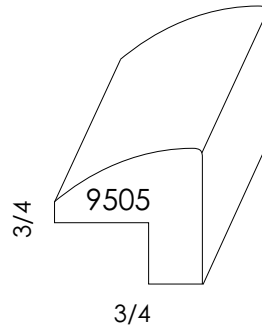
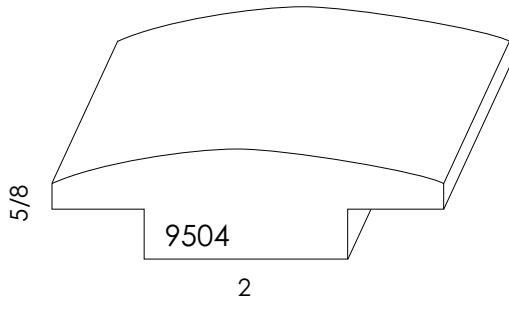
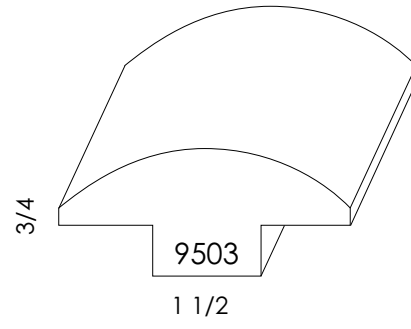
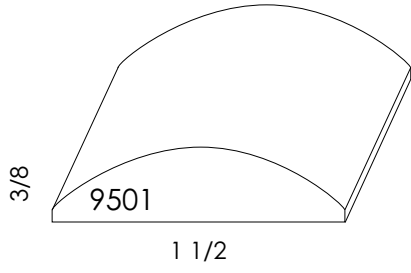

Transition Mold

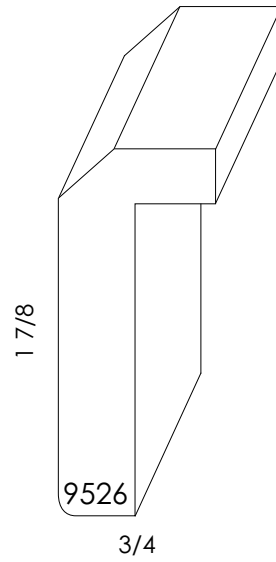
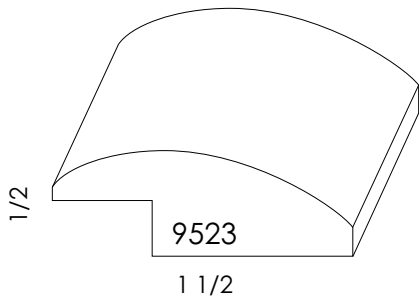
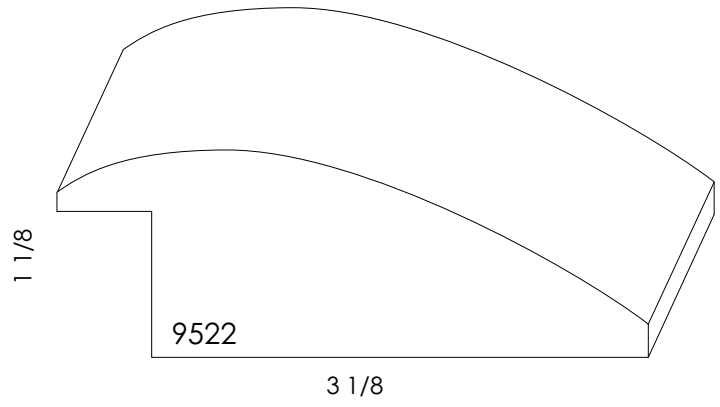
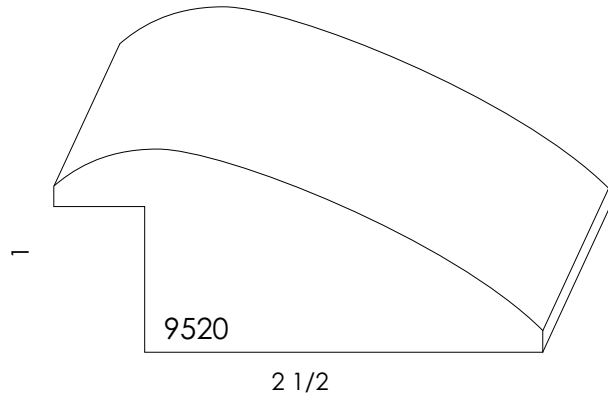
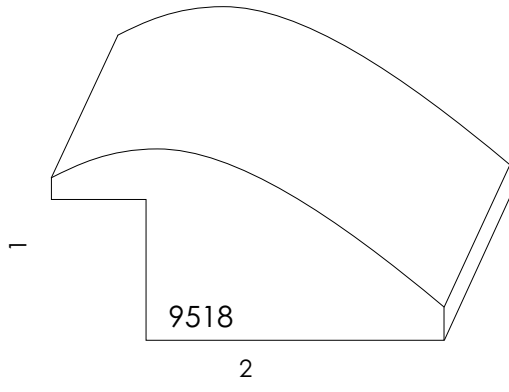

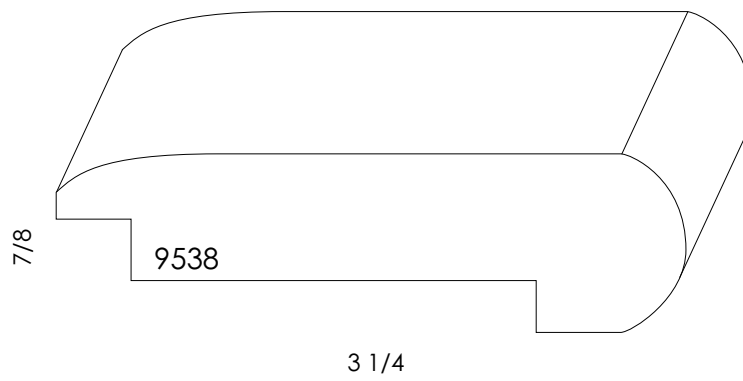
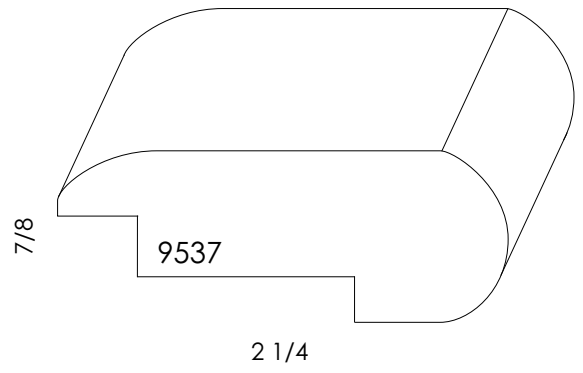
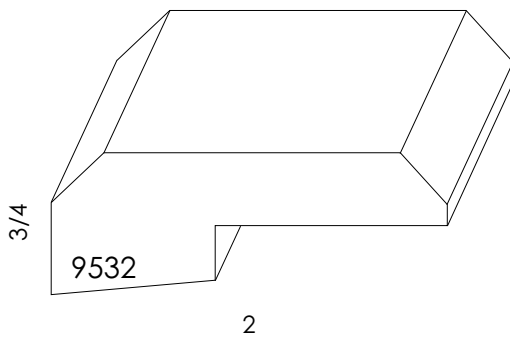
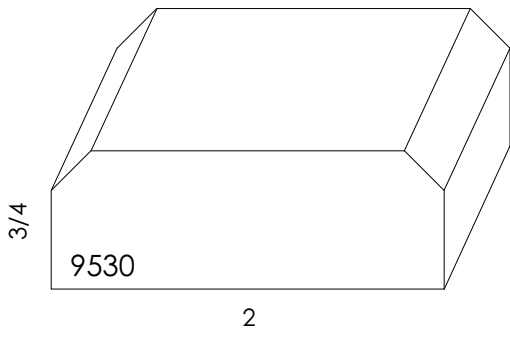



Ultralight MDF

Ultralight Medium Density Fiberboard (MDF), composed of wood fibres from Radiata Pine combined with a synthetic resin and wax, is an ecologically sound product and an excellent substitute for solid wood mouldings.

Ultralight MDF Qualities

- will not warp, crack or split
- ultra primed surface that requires less prep work
- requires no sanding which allows for deeper profiles
- no finger joints to break or raise through the finish
- creates less waste due to convenient specified lengths
- no “volcano” effect when nailing

Handling

- always carry Ultralite MDF on edge as this will reduce stress caused by bending and flexing

Finishing

- putty should be solvent based (spot prime area if using latex paints)
- use a slow dry acrylic latex caulk
- can apply a bead of caulk along the top edge of all base profiles, joints between lengths of mouldings, and all seams between crown mouldings (roof and wall)
- paint should be oil-based enamel gloss, semi-gloss acrylic latex gloss, or semi-gloss
- sand lightly between coats of paint for a superior finish

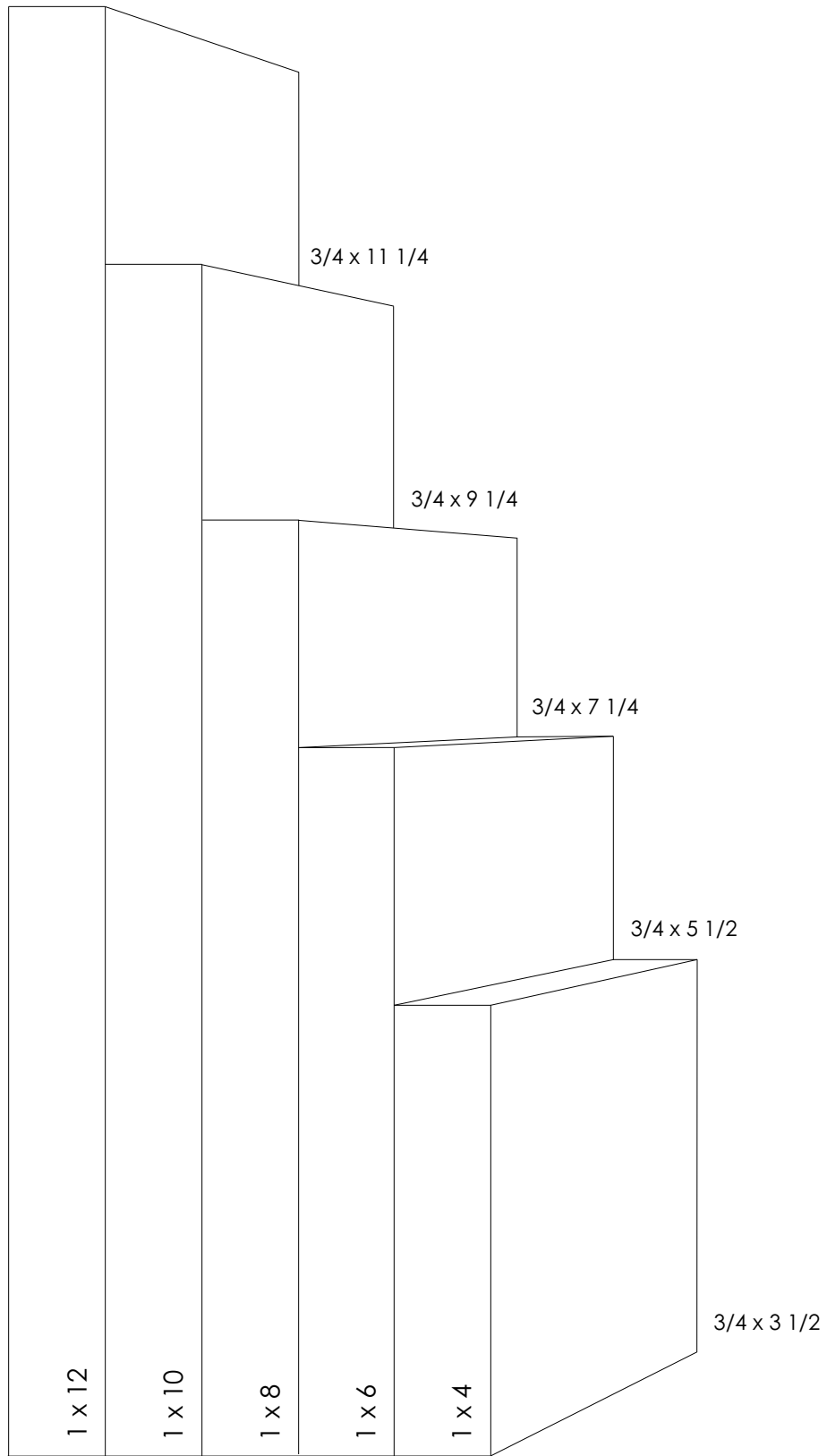

stock MDF S4S

stock MDF Casing

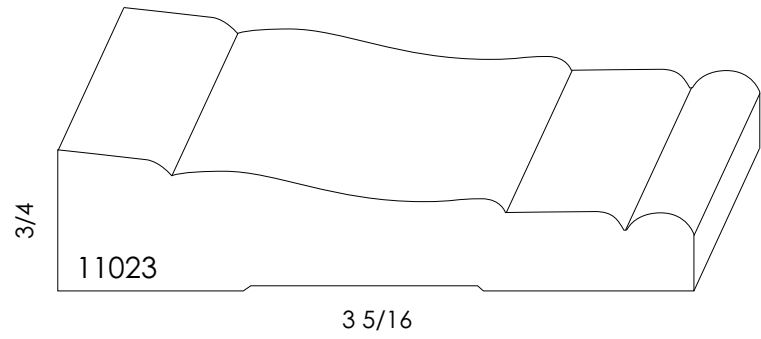
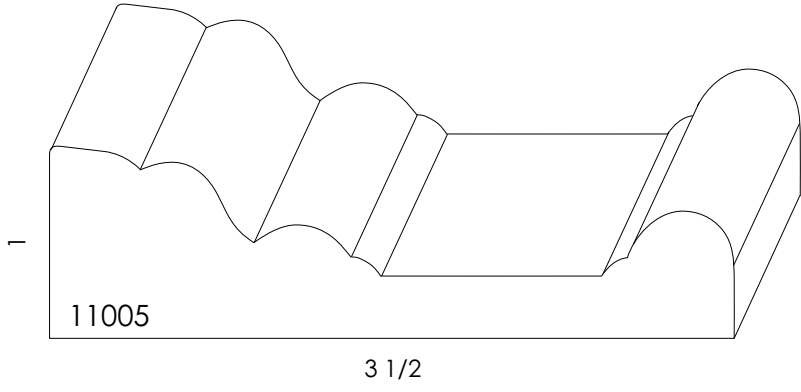
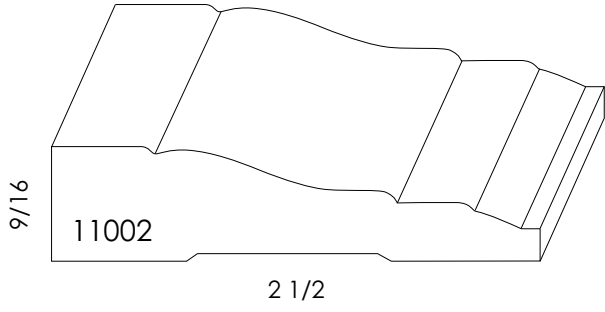
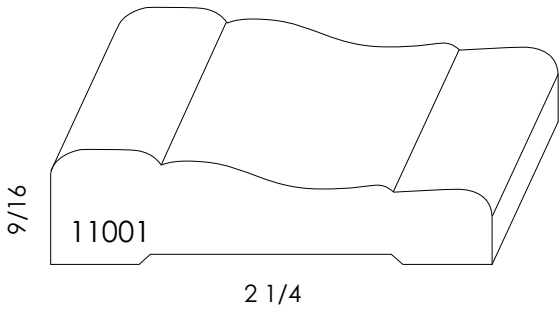

Stock MDF Base

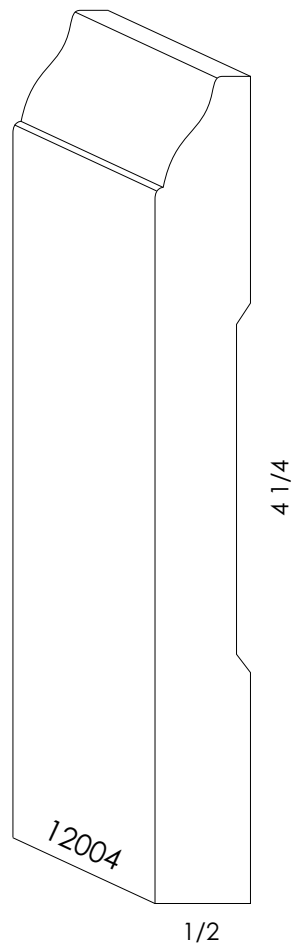
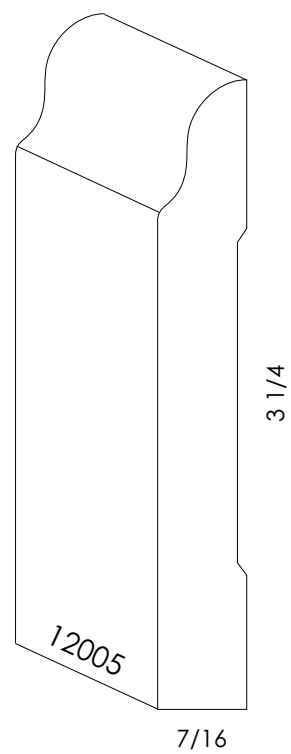
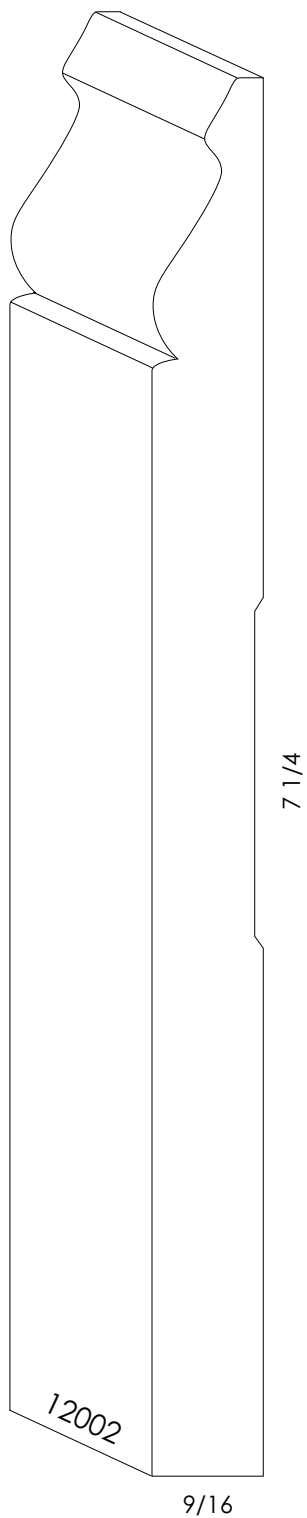
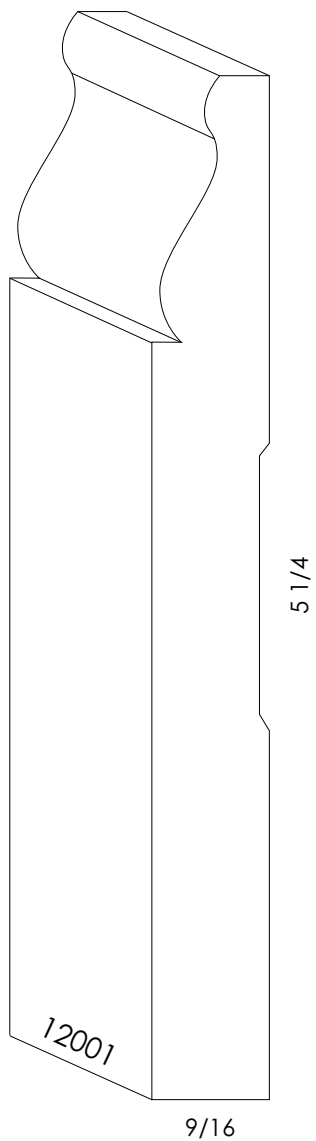

stock MDF Crown

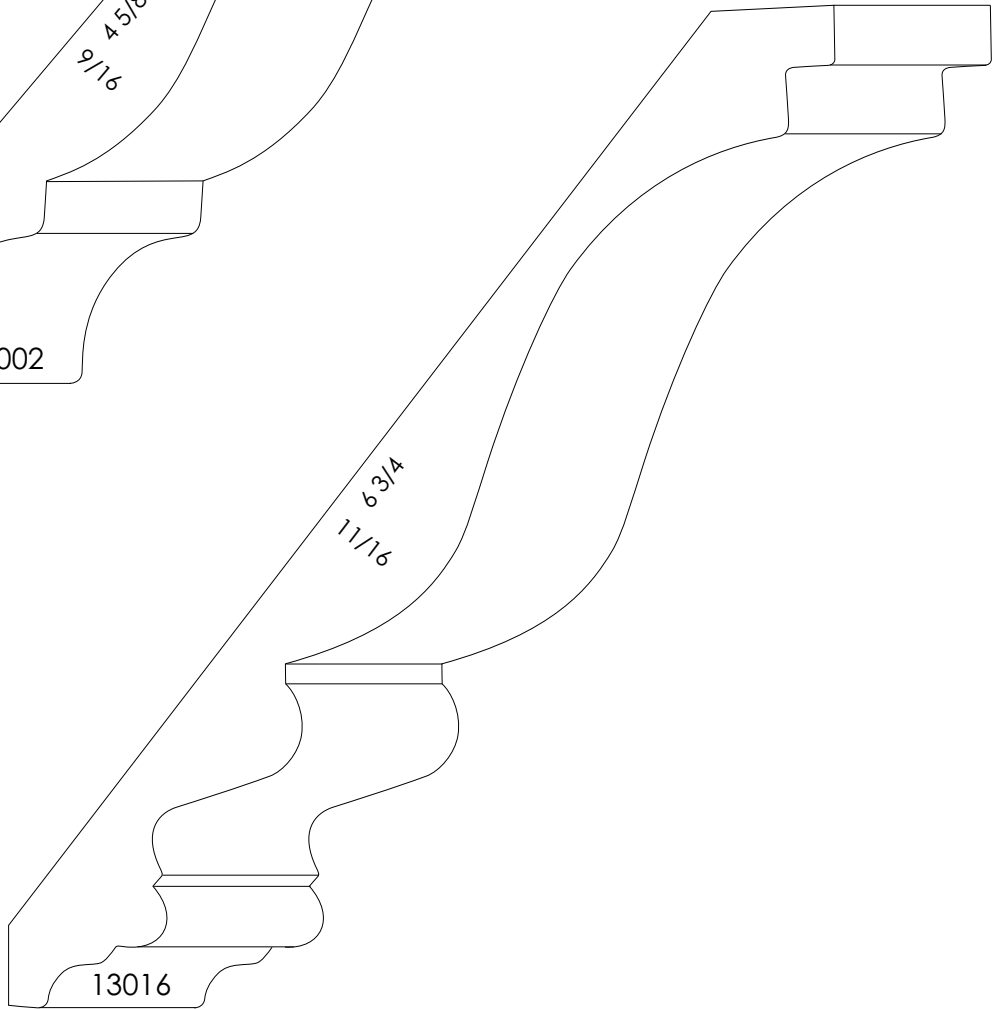
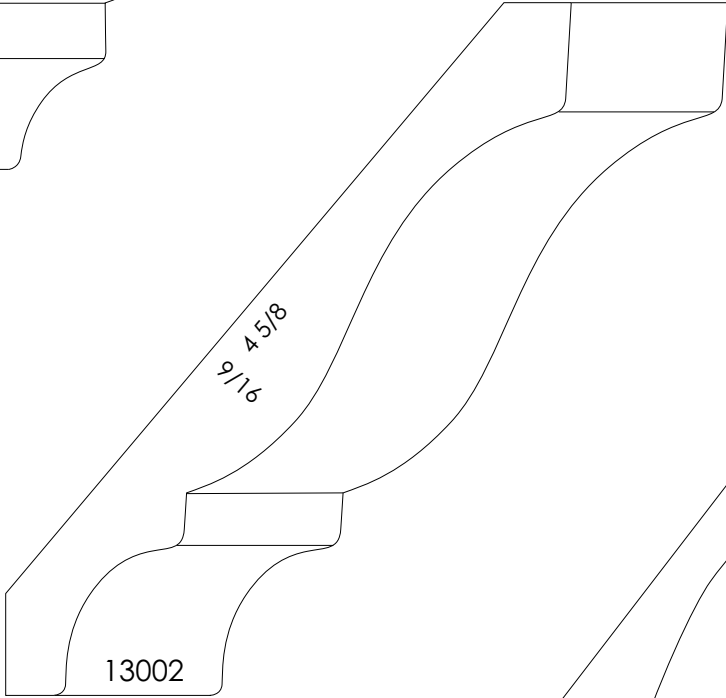
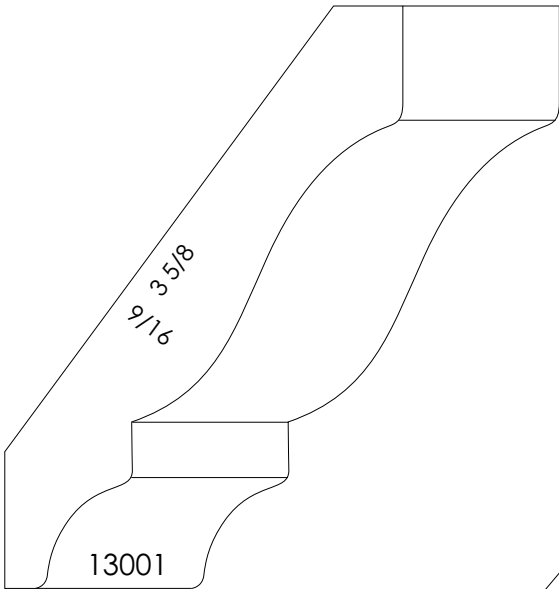

stock MDF Chair Rail

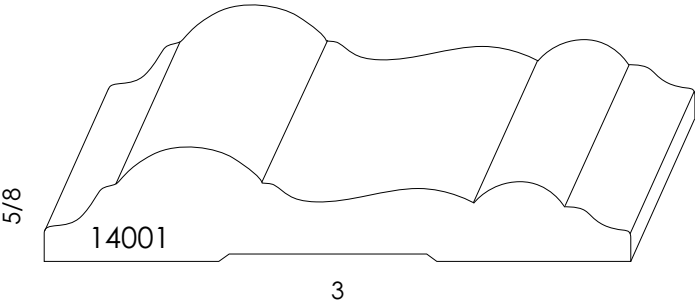

stock MDF Base Cap

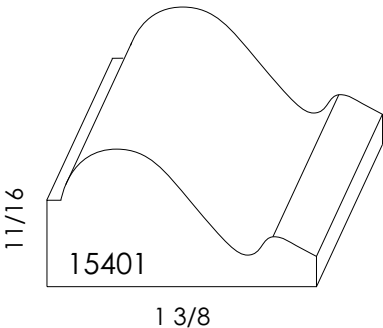

MDF Casing

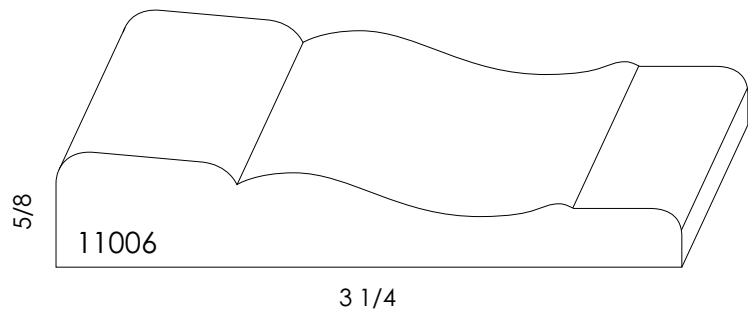
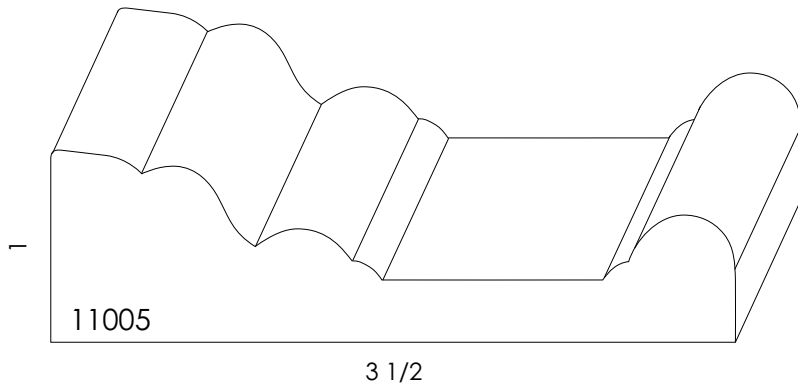
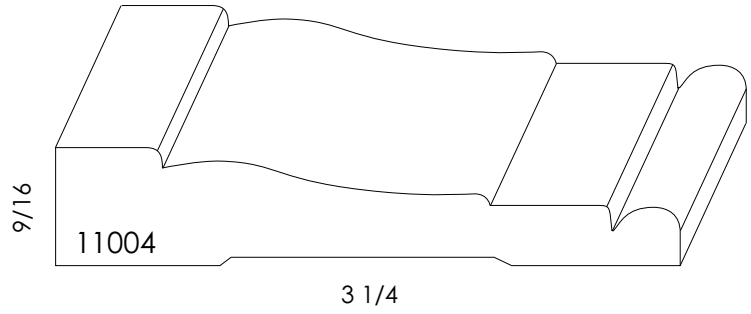
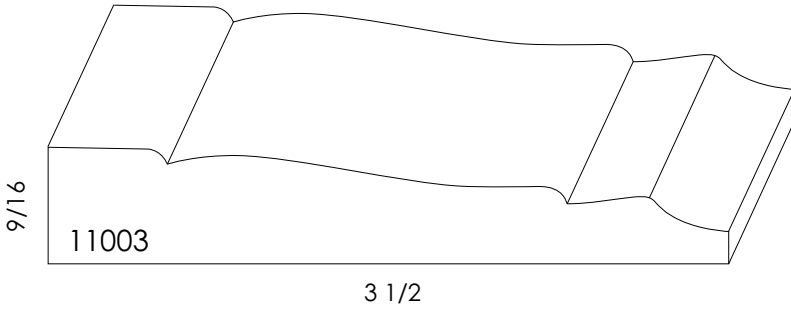
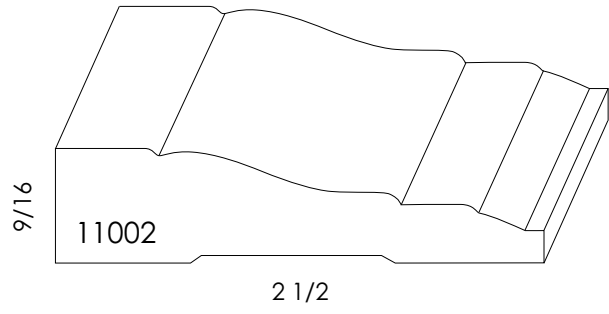
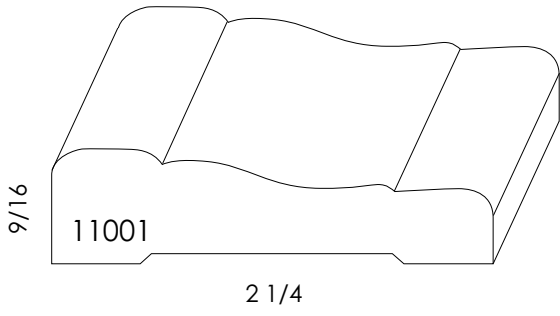

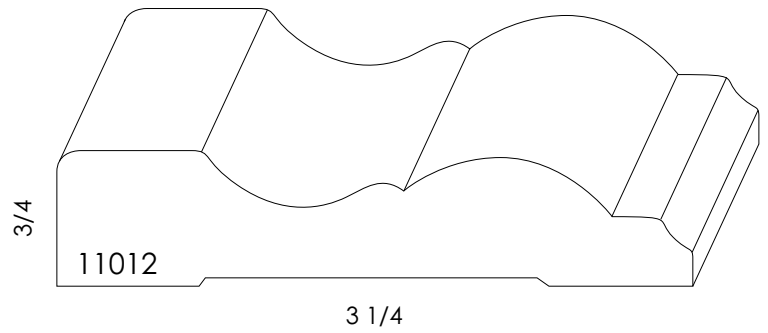
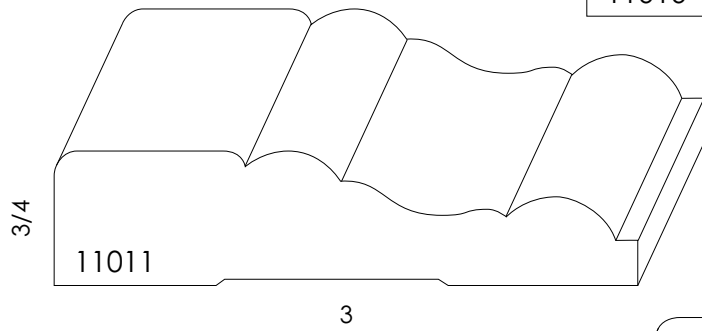
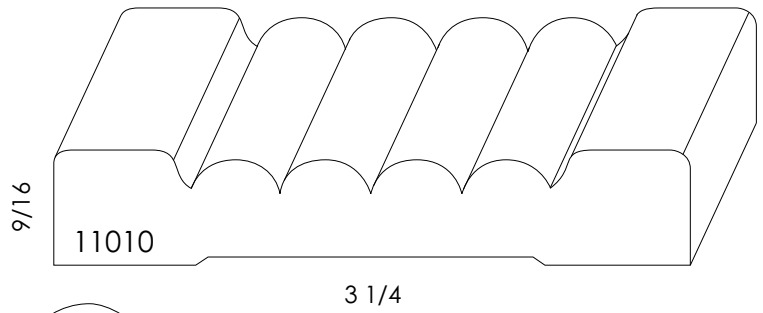
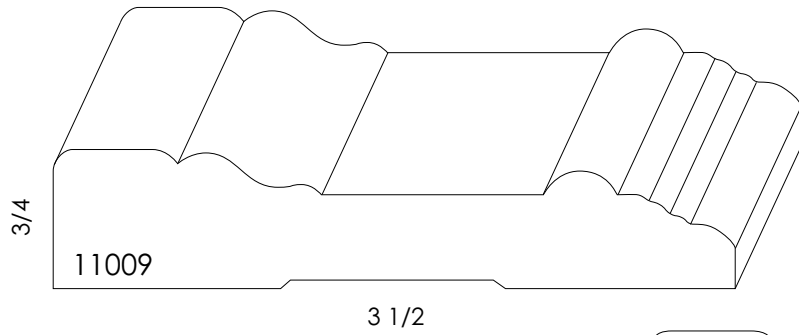
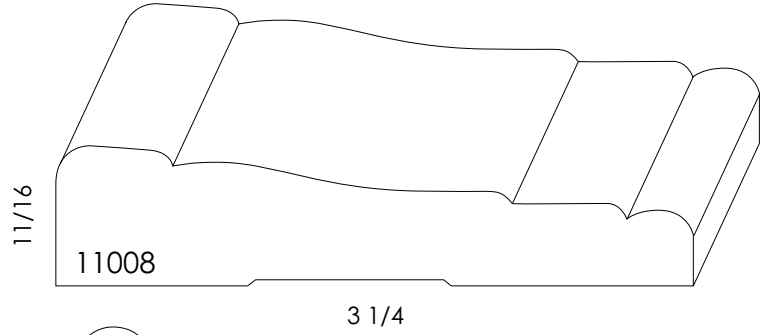
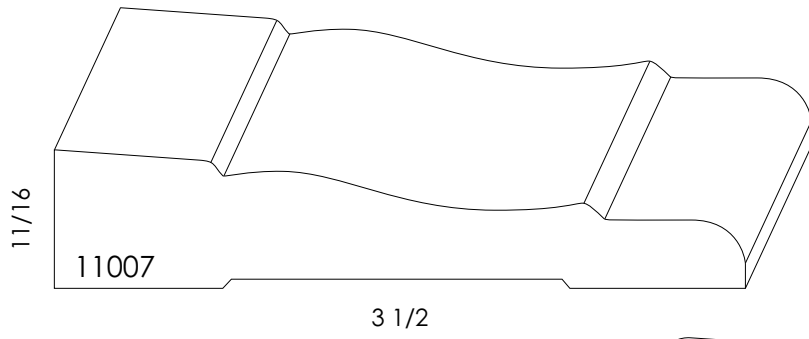

MDF Casing

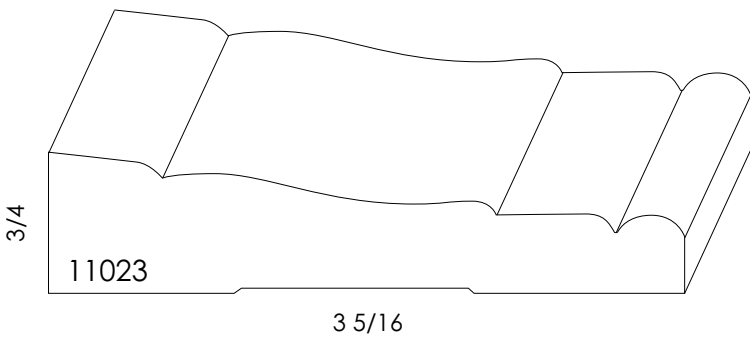
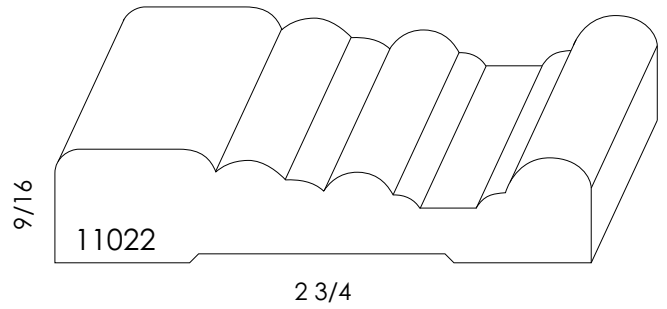
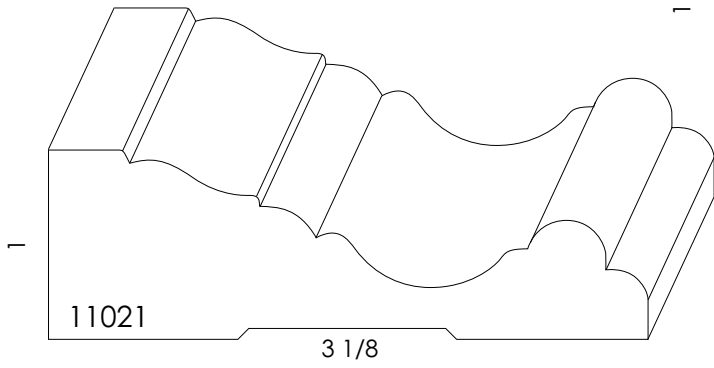
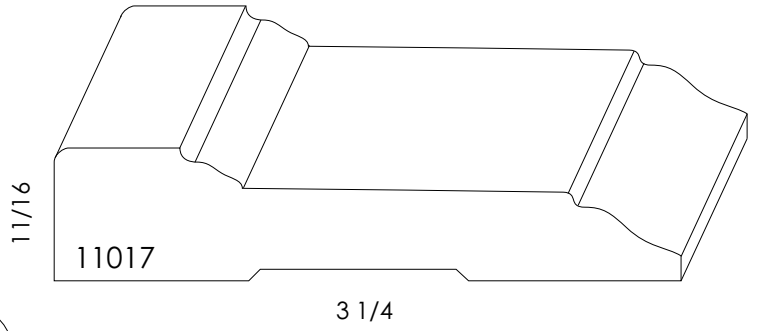
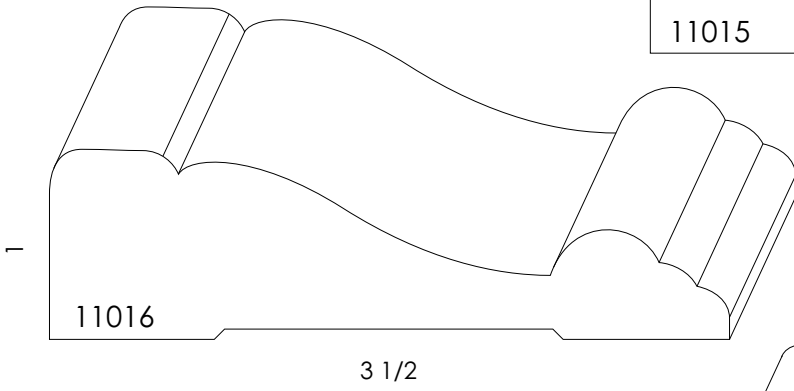
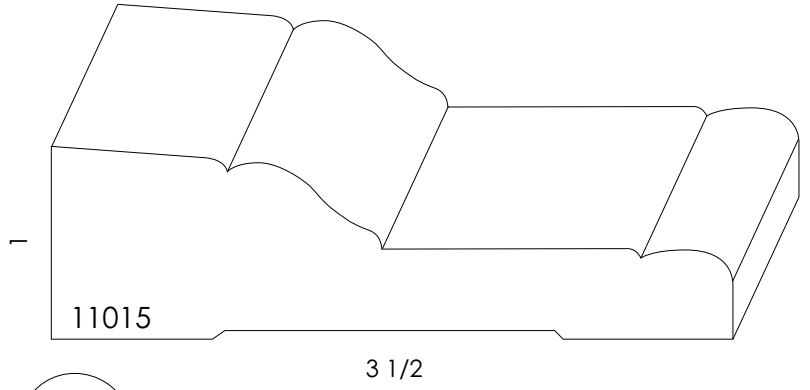
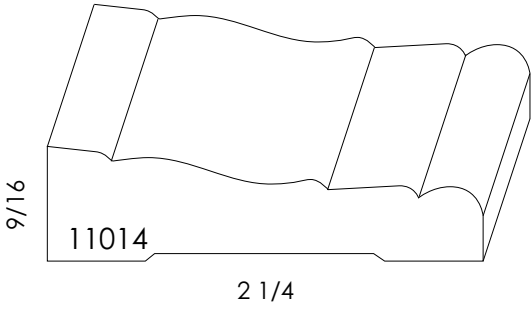

MDF Base

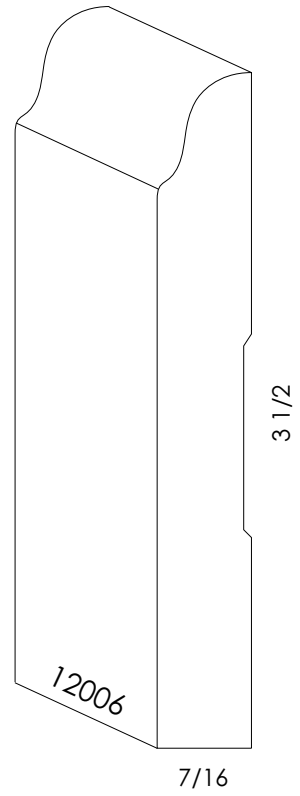
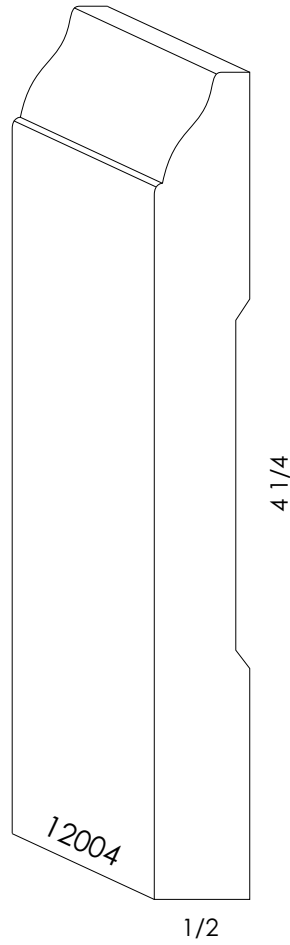
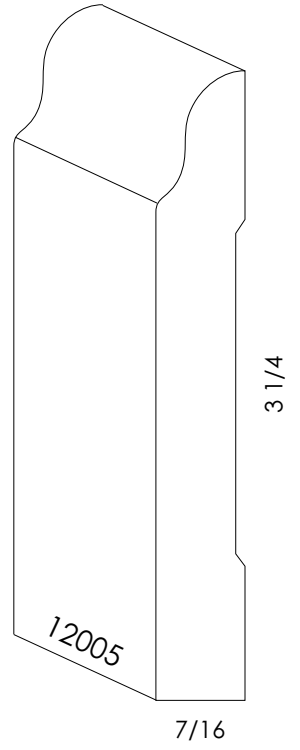
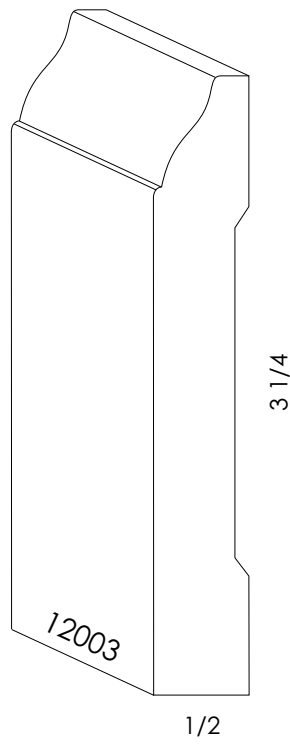
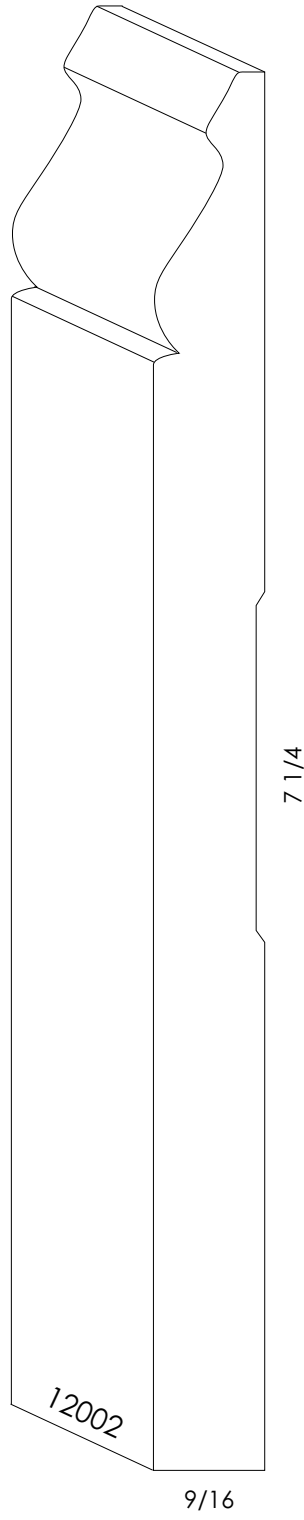
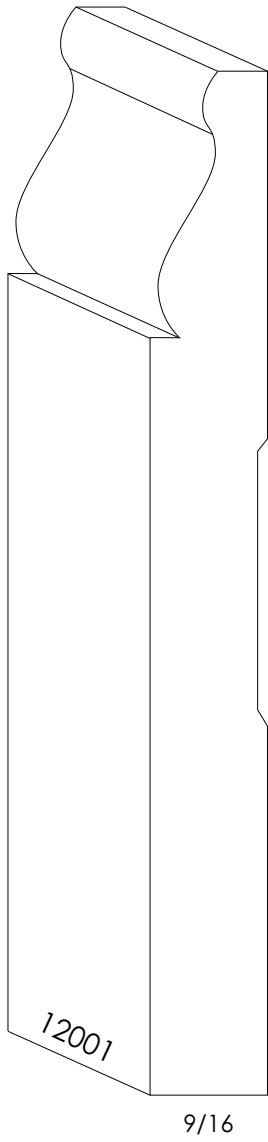

MDF Base

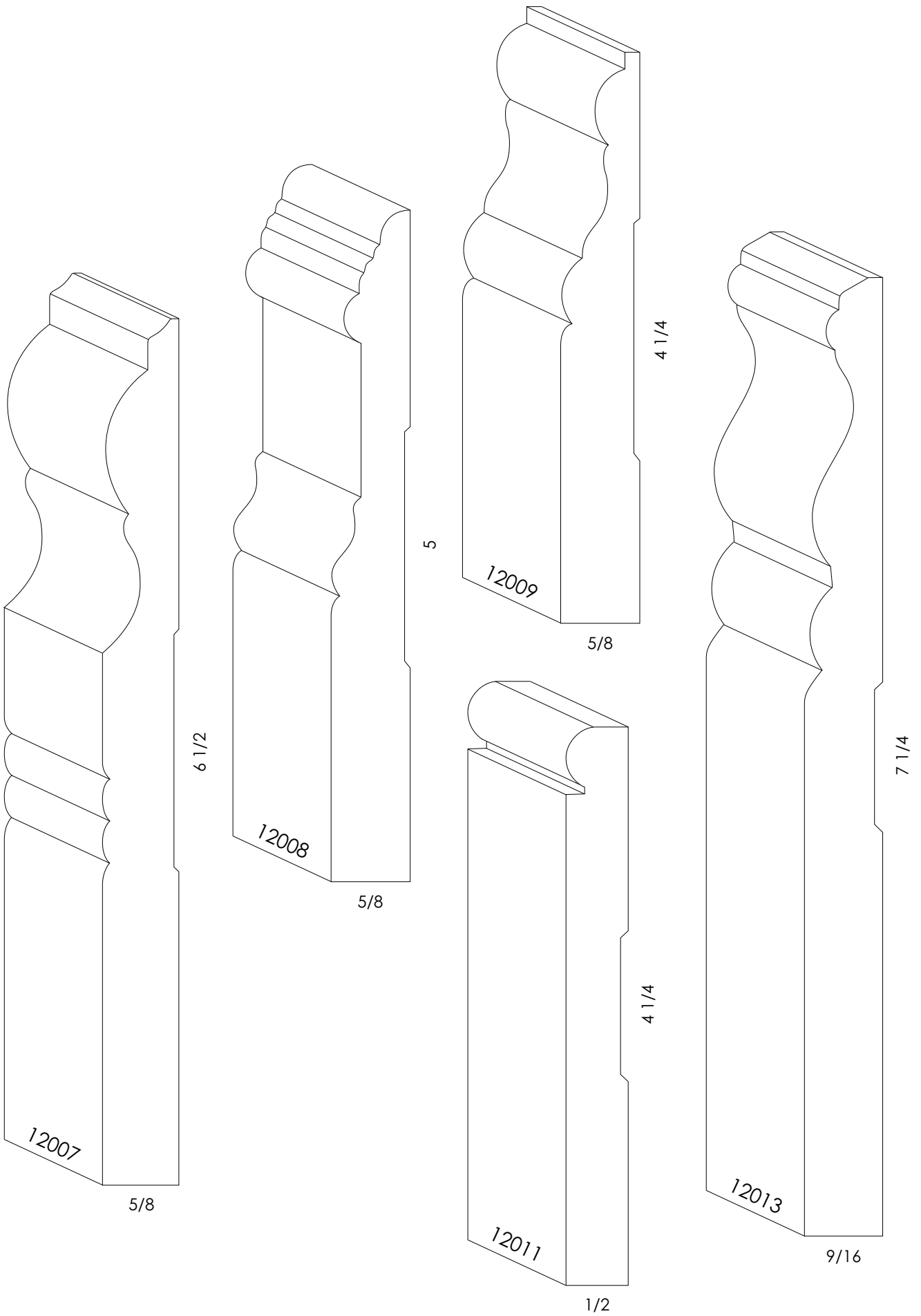

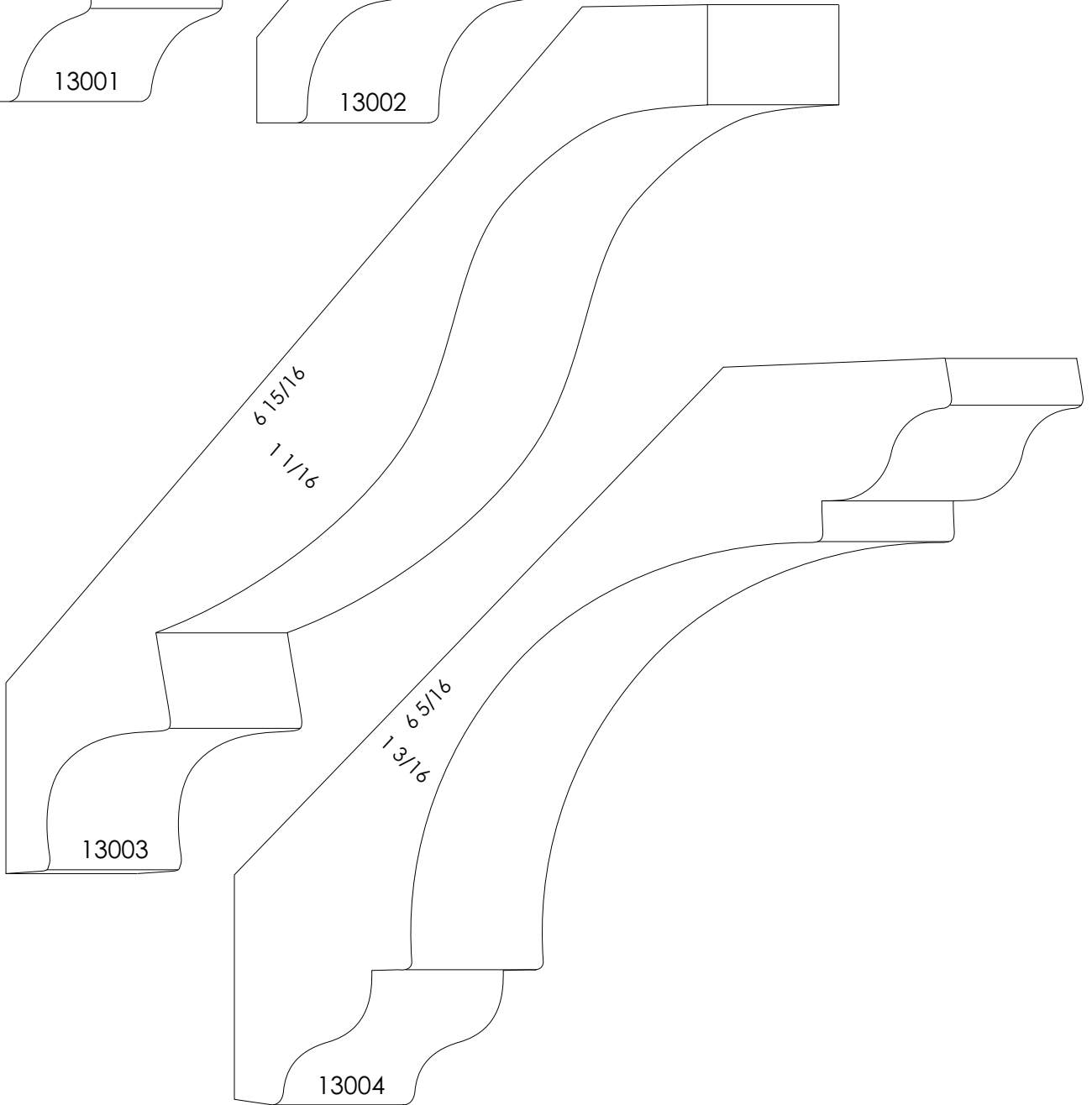
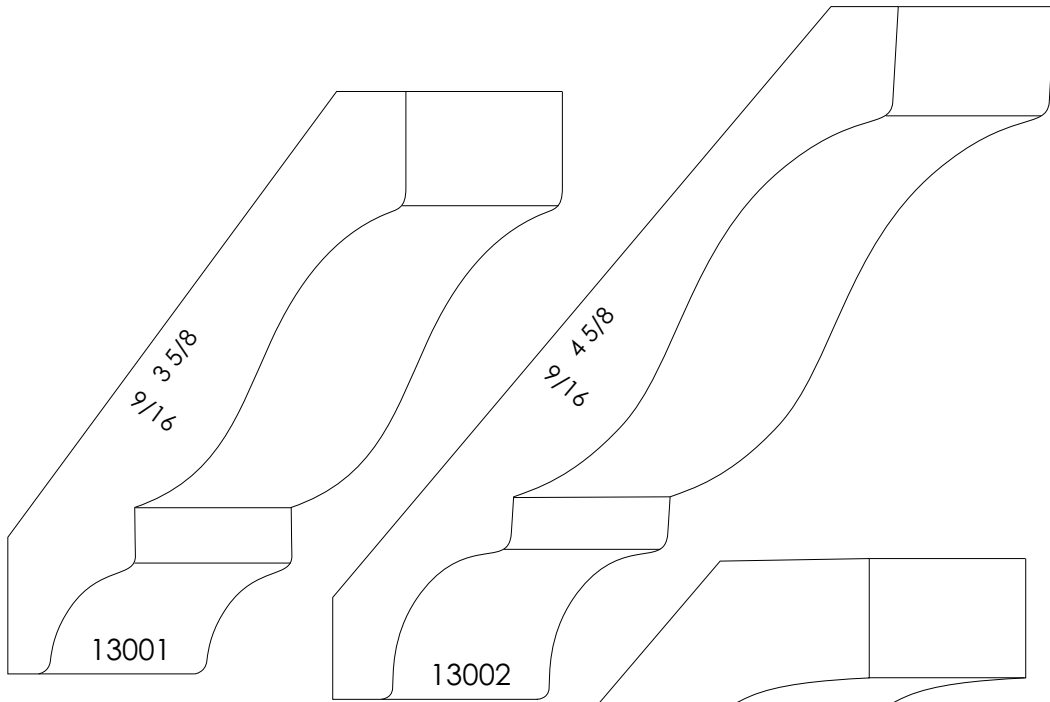

MDF Crown

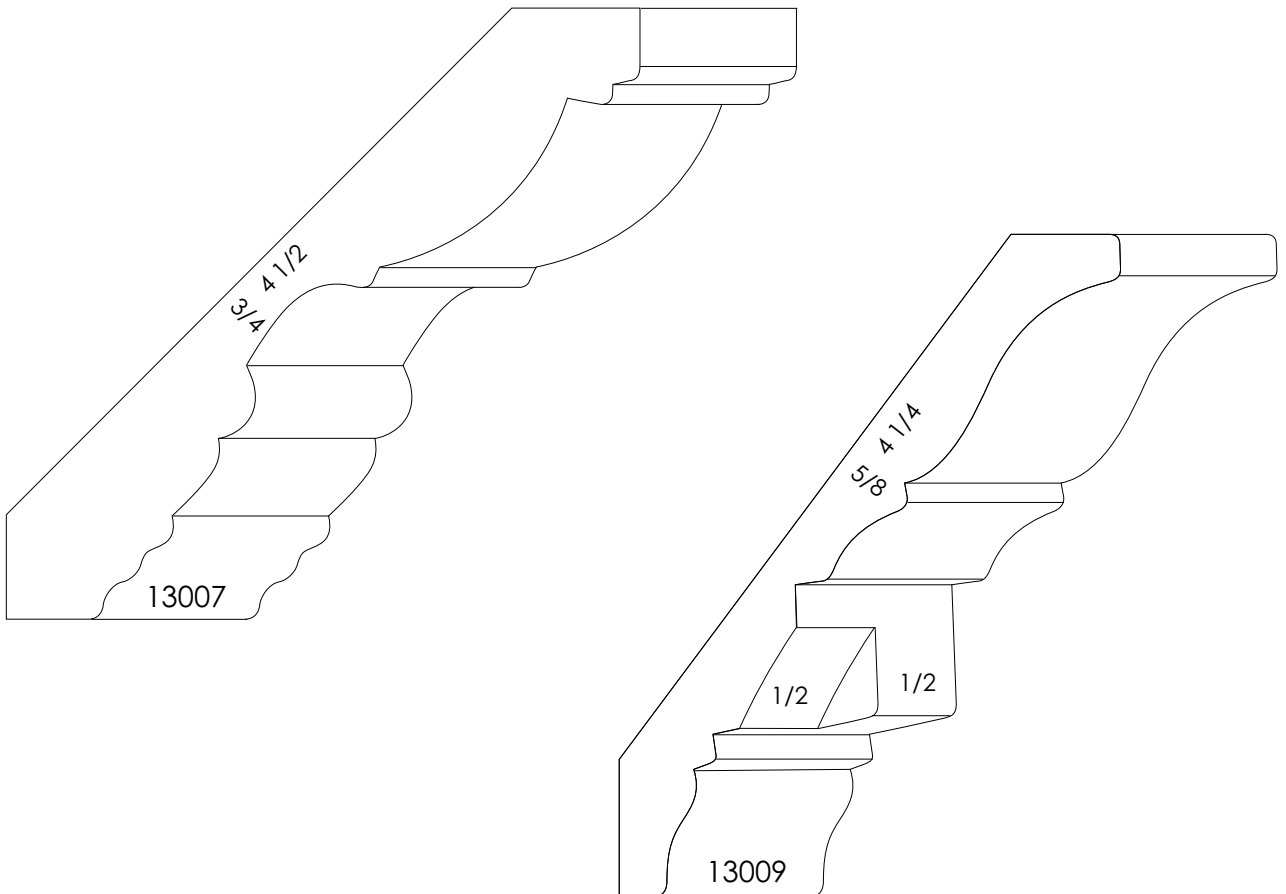
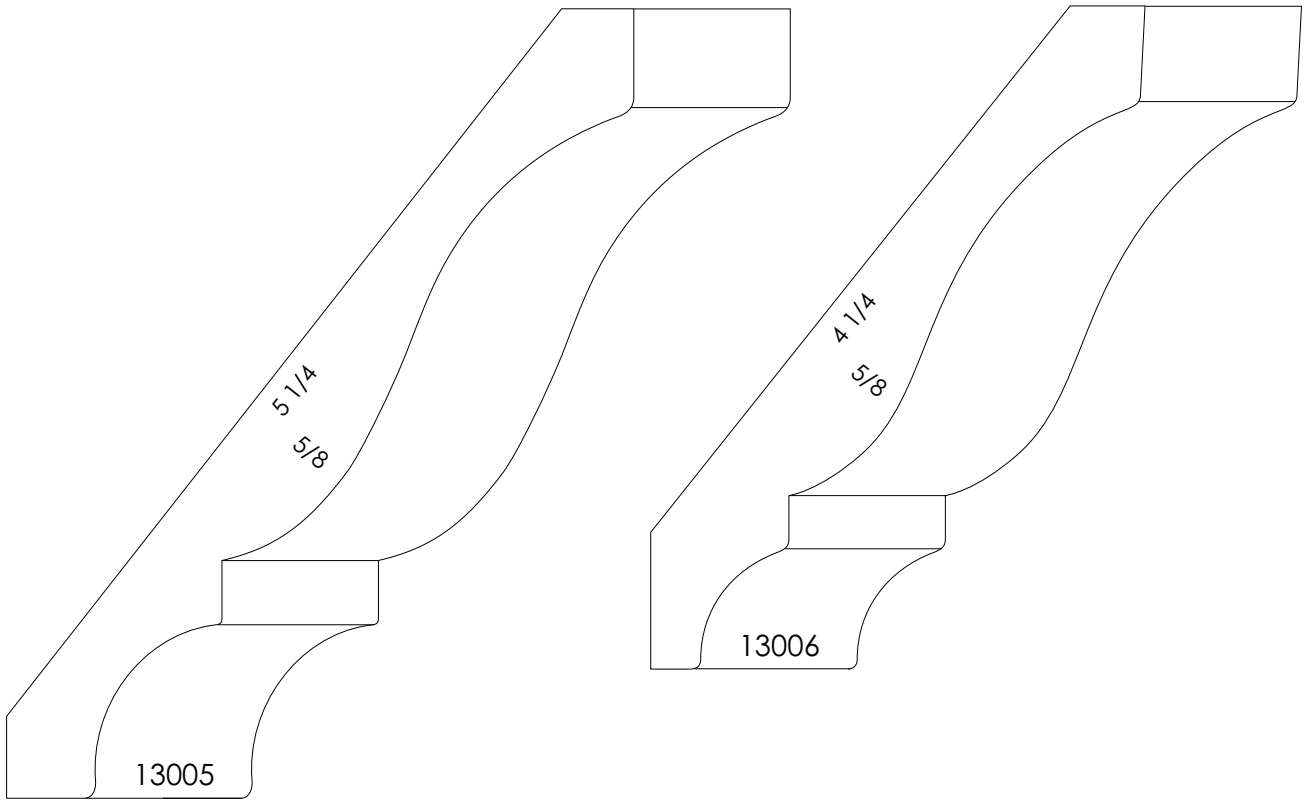

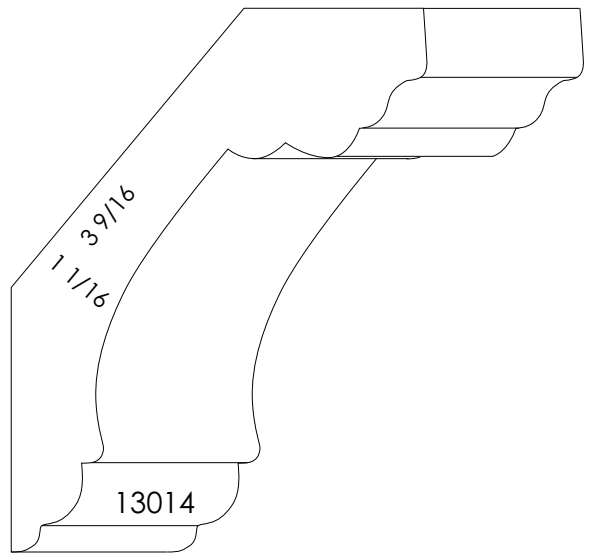
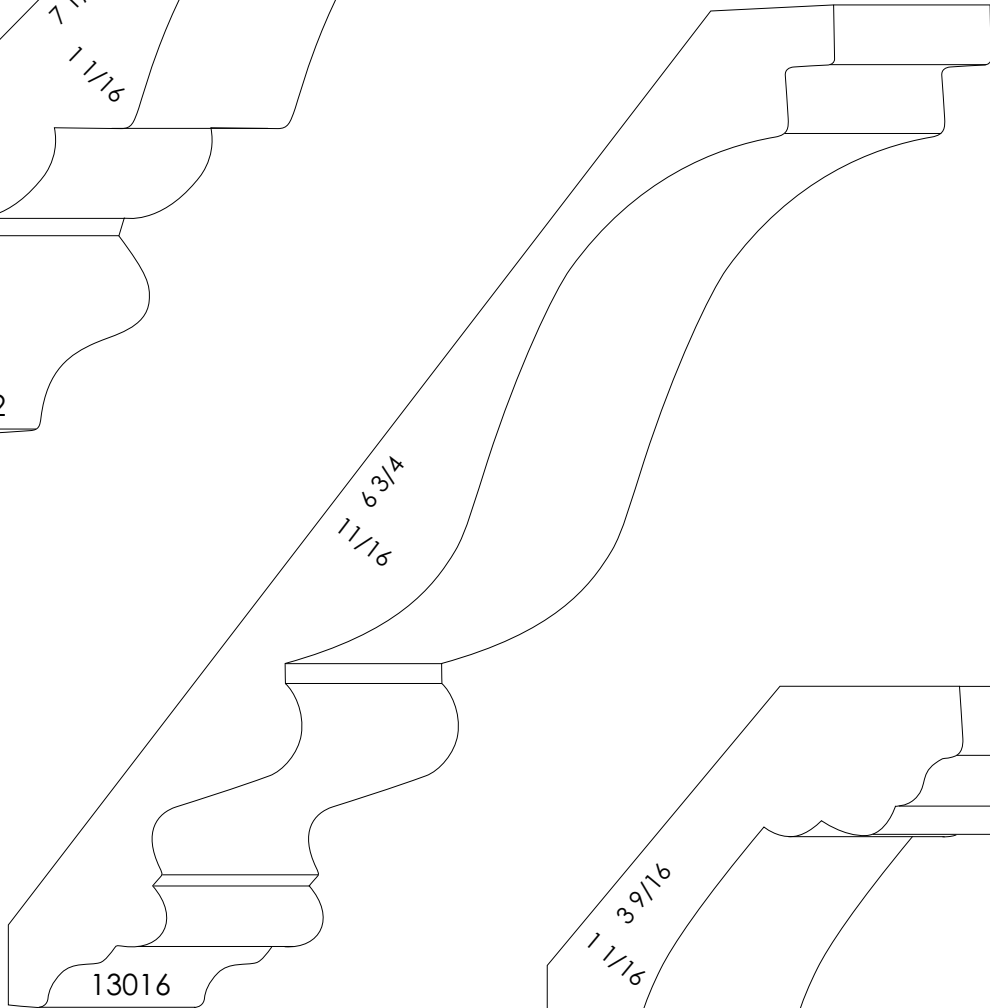
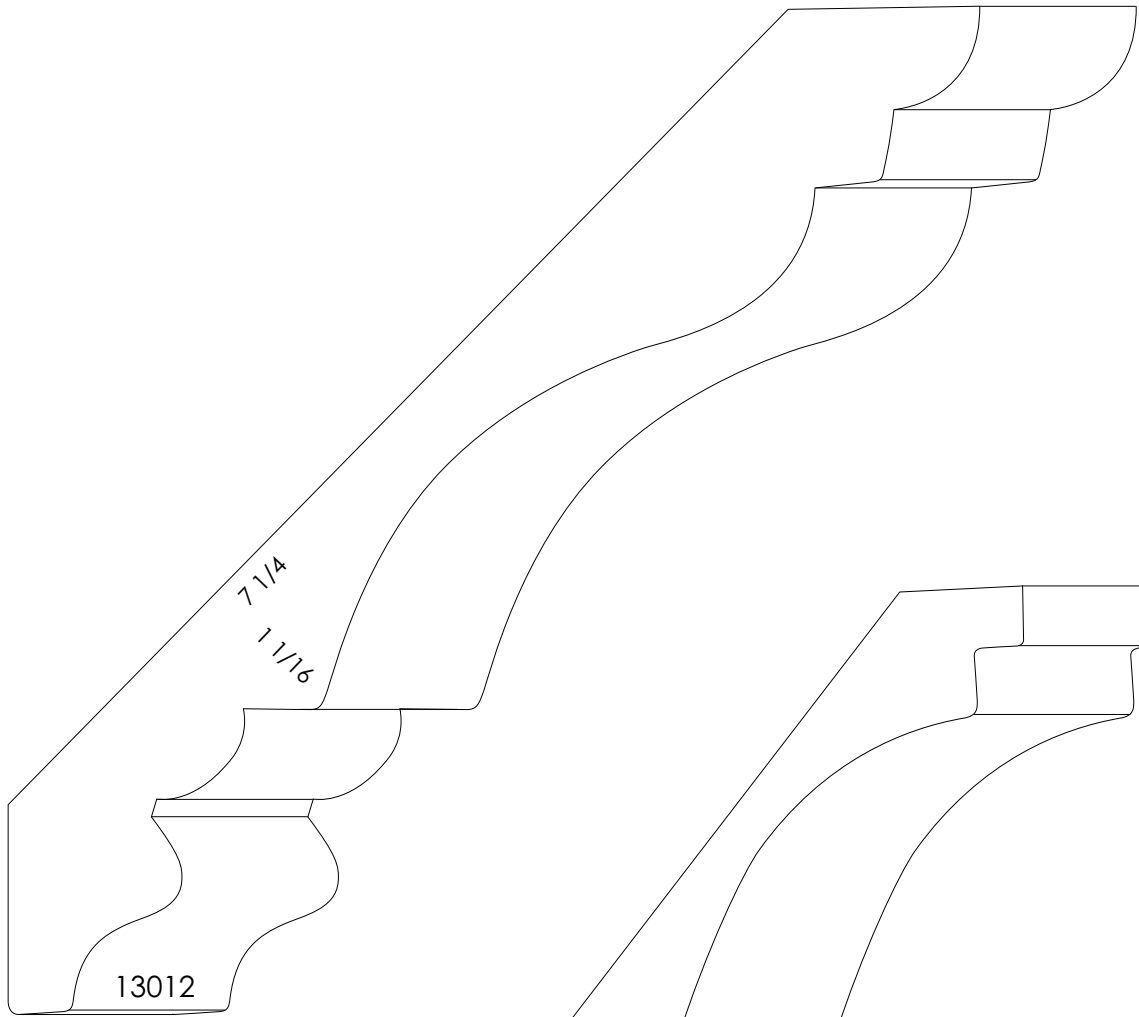

MDF Chair Rail

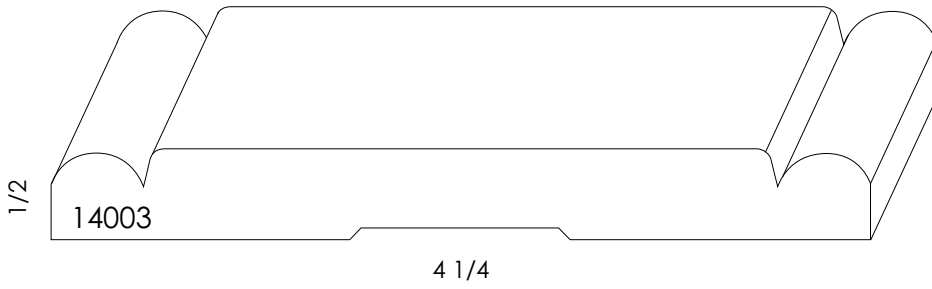
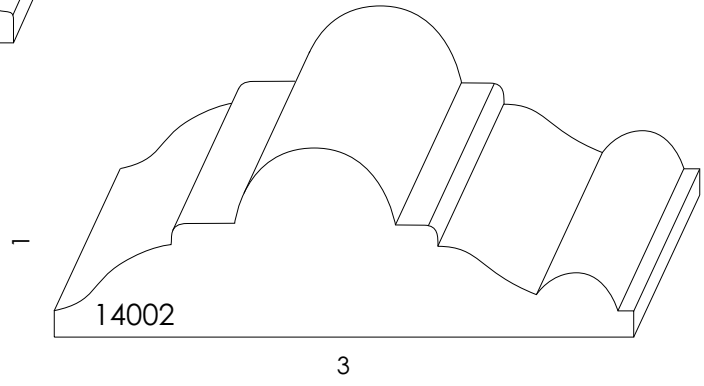
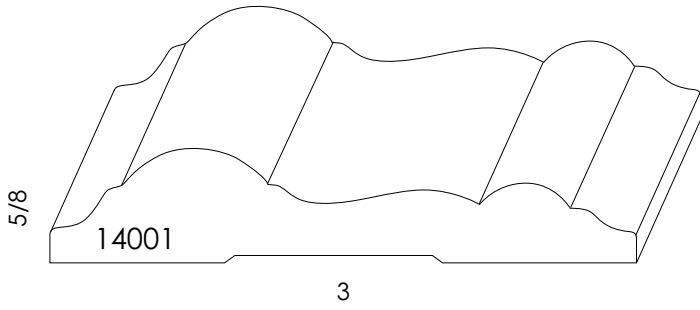

MDF Window Sill

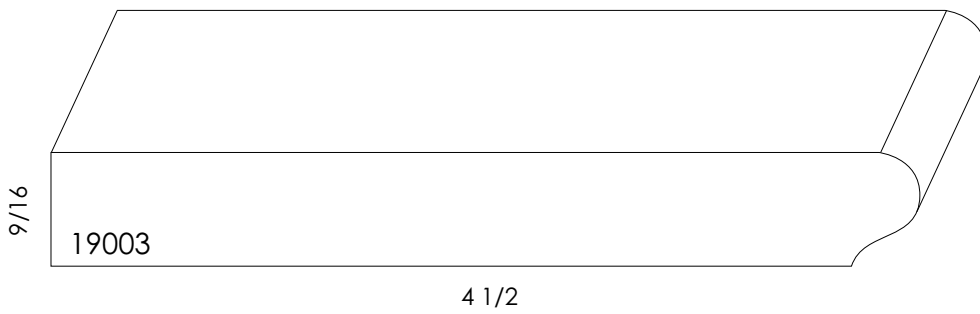
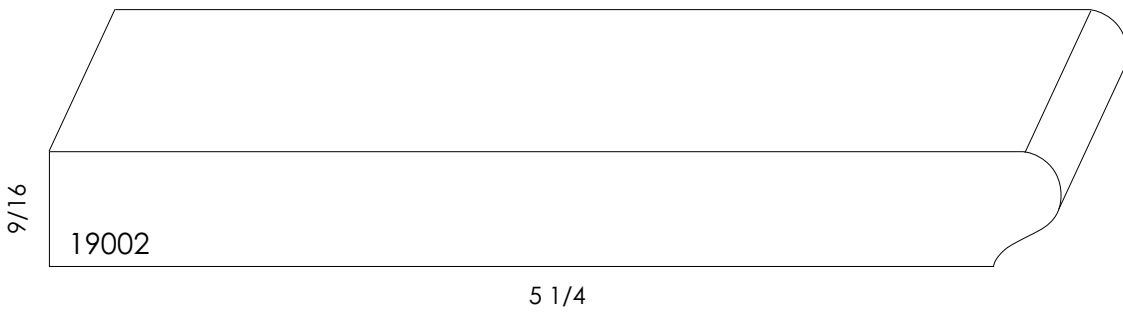

MDF Architrave

MDF Base Cap

MDF Wainscot

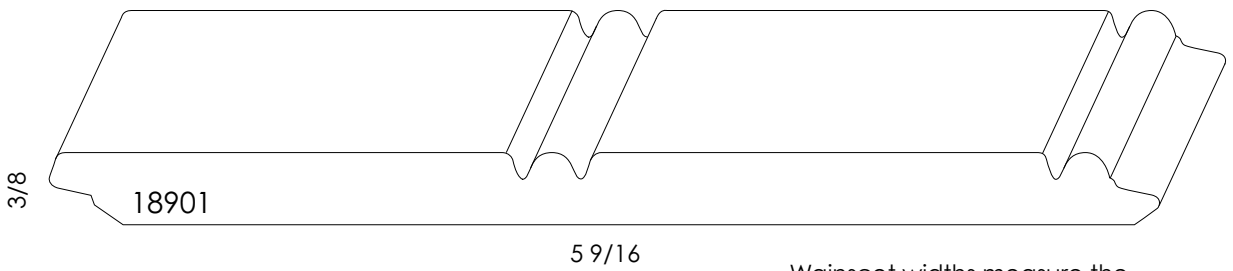
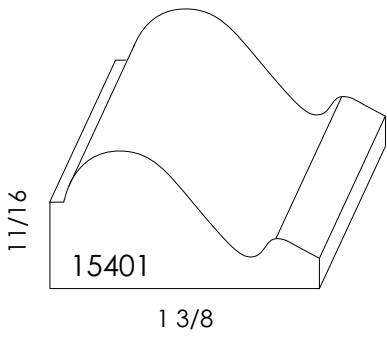
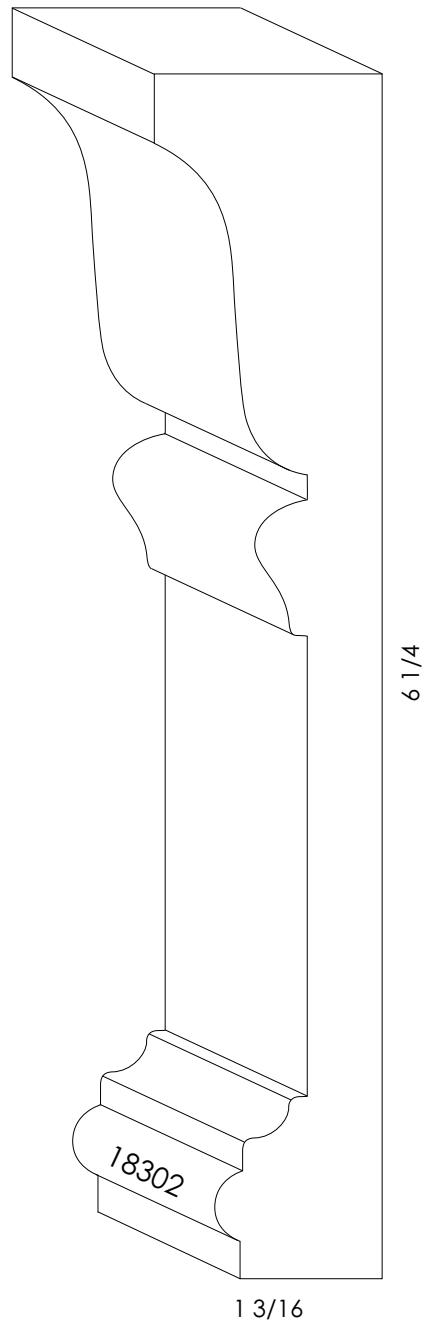

Wainscot widths measure the exposed face only.



Customized Details and Design Ideas

From showing the available styles and sizes of rosette and crown blocks to creating 3-D illustrations for a beam or wainscoting, this section is intended to help you master the details of your design.

Arched Casings and Jambs

Select from our available casings styles and we will custom fit almost any radius or elliptical entryway or window. Custom arched jambs are also available.

Rosette and Plinth Blocks

We inventory the sizes and styles shown below in a variety of wood species. We can also create a custom design of your choosing.

Style	Width	Depth
1	4 3/4	1 1/16
	5 3/4	1 1/16
2	3 3/4	1 1/16
	4	1 1/16
3	2 3/4	15/16

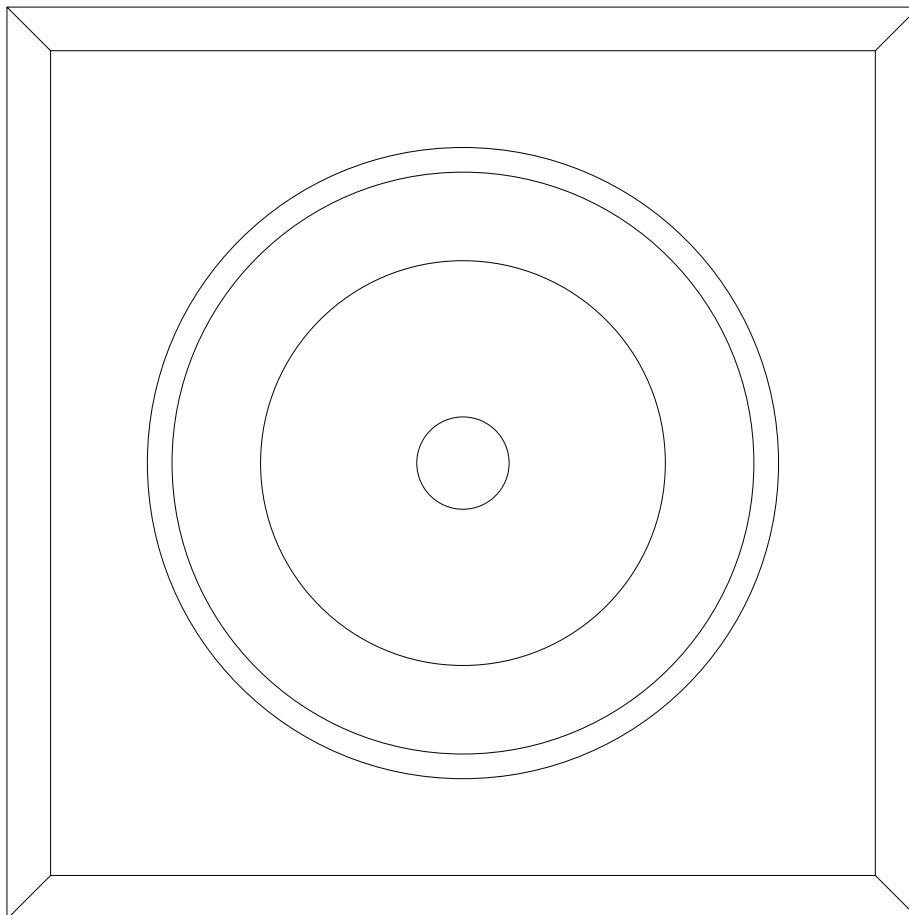

Style 1

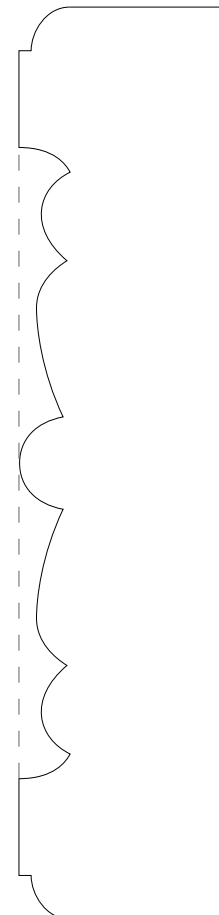

1 1/16

4 3/4

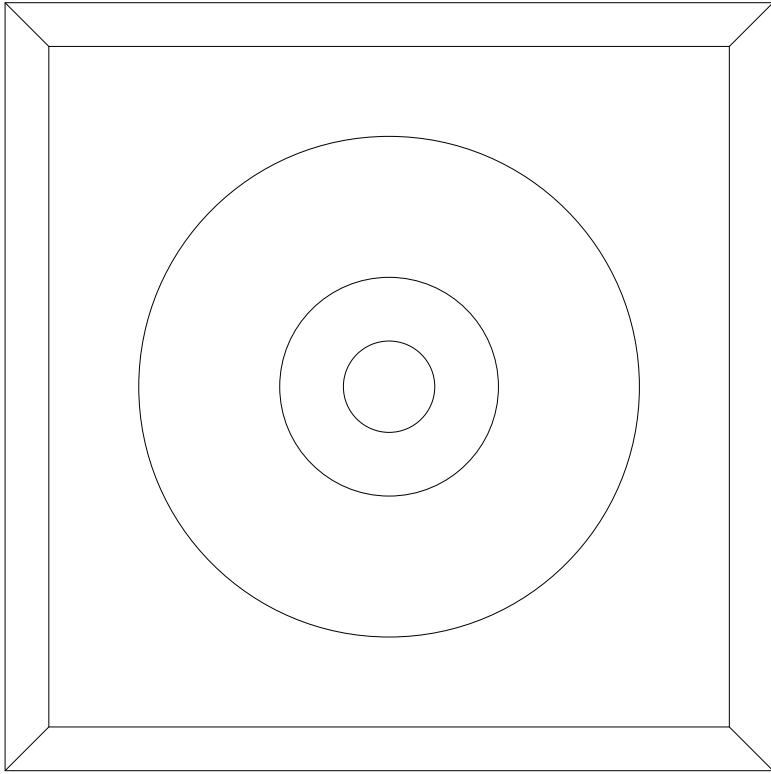

Style 2

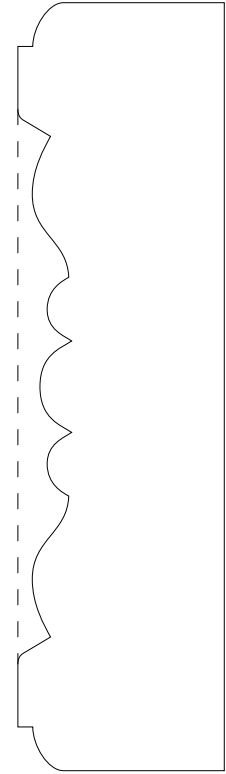

$1 \frac{1}{16}$

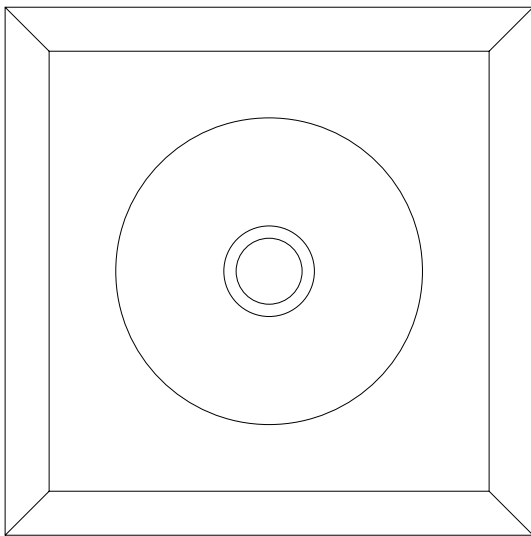

Style 3

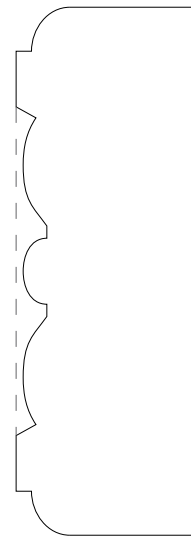

$1 \frac{5}{16}$

4

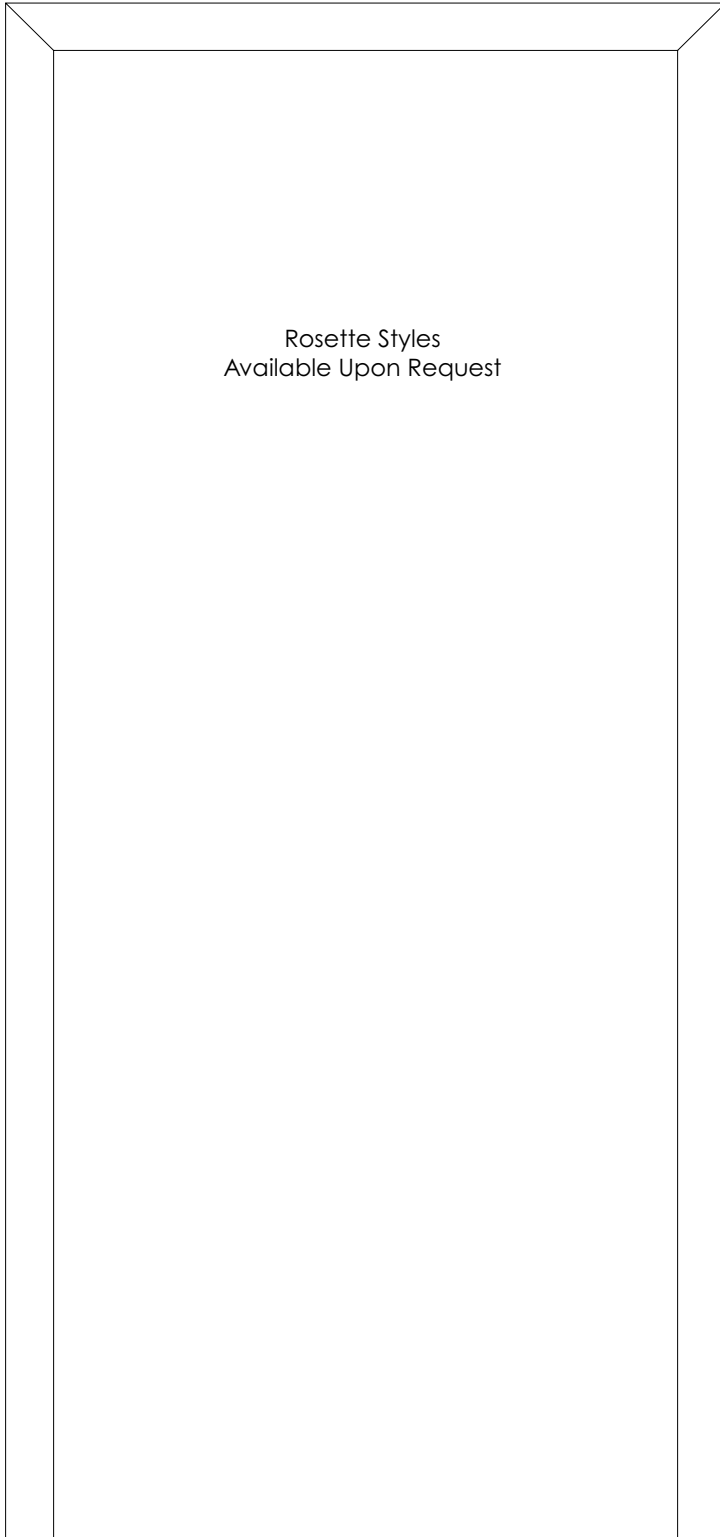

Rosette Styles
Available Upon Request

Plinth Block

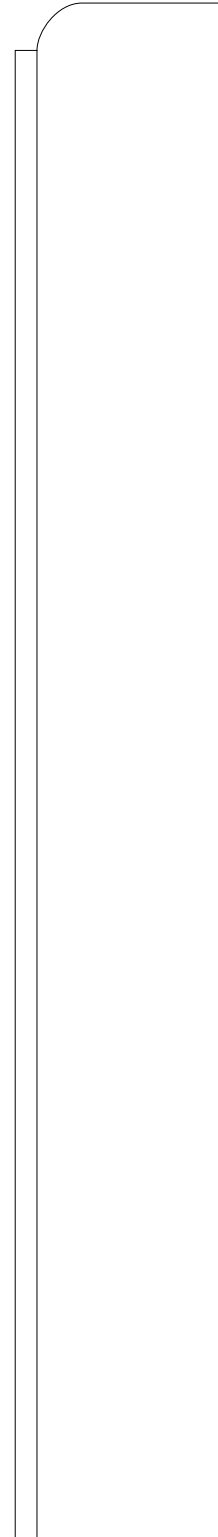

8

1 1/16

Mantles

Solid wood mantles and mantle legs can be created from our moulding styles to complete a custom design. Below is an example of a mantle using two popular moulding styles and S4S lumber.

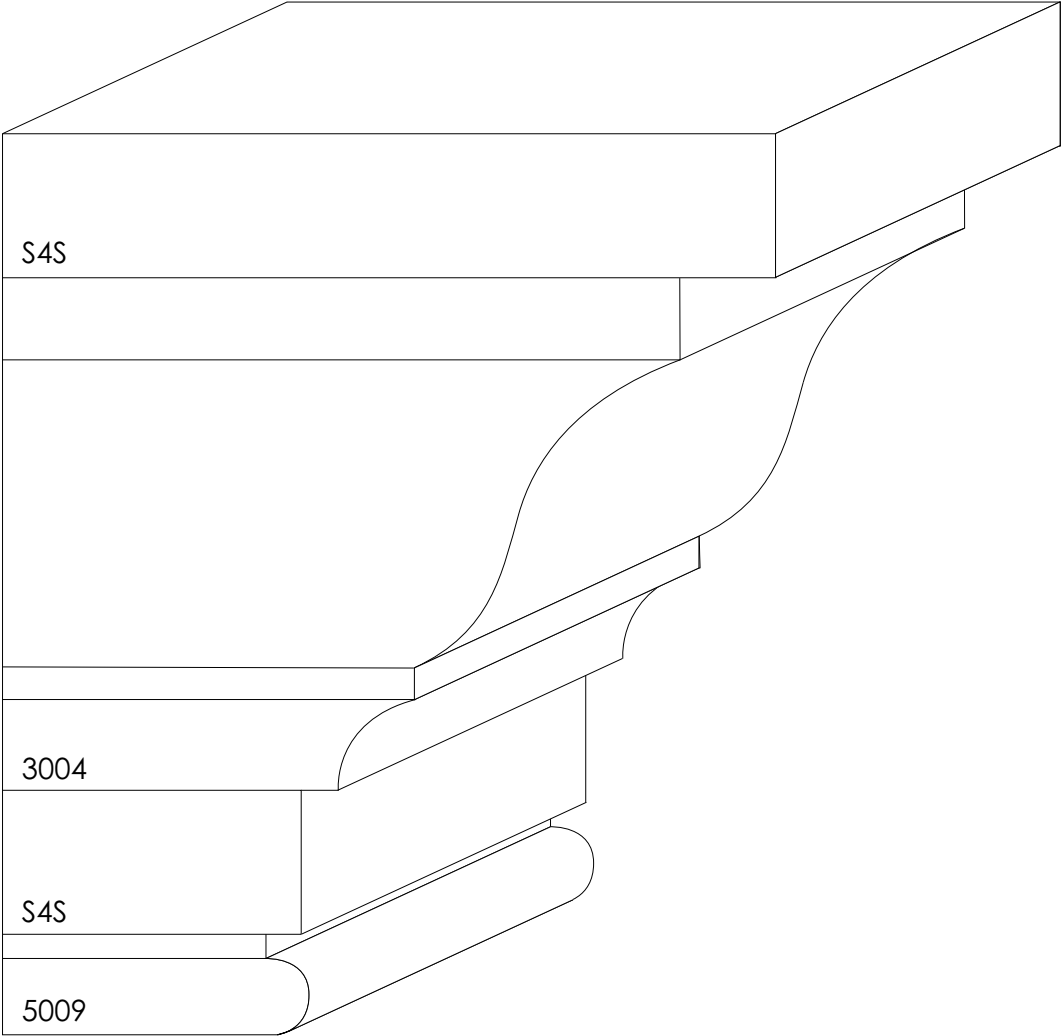

Dentil Mould

Shown below are the two styles of dentil mold that we inventory. Custom sizes are available.

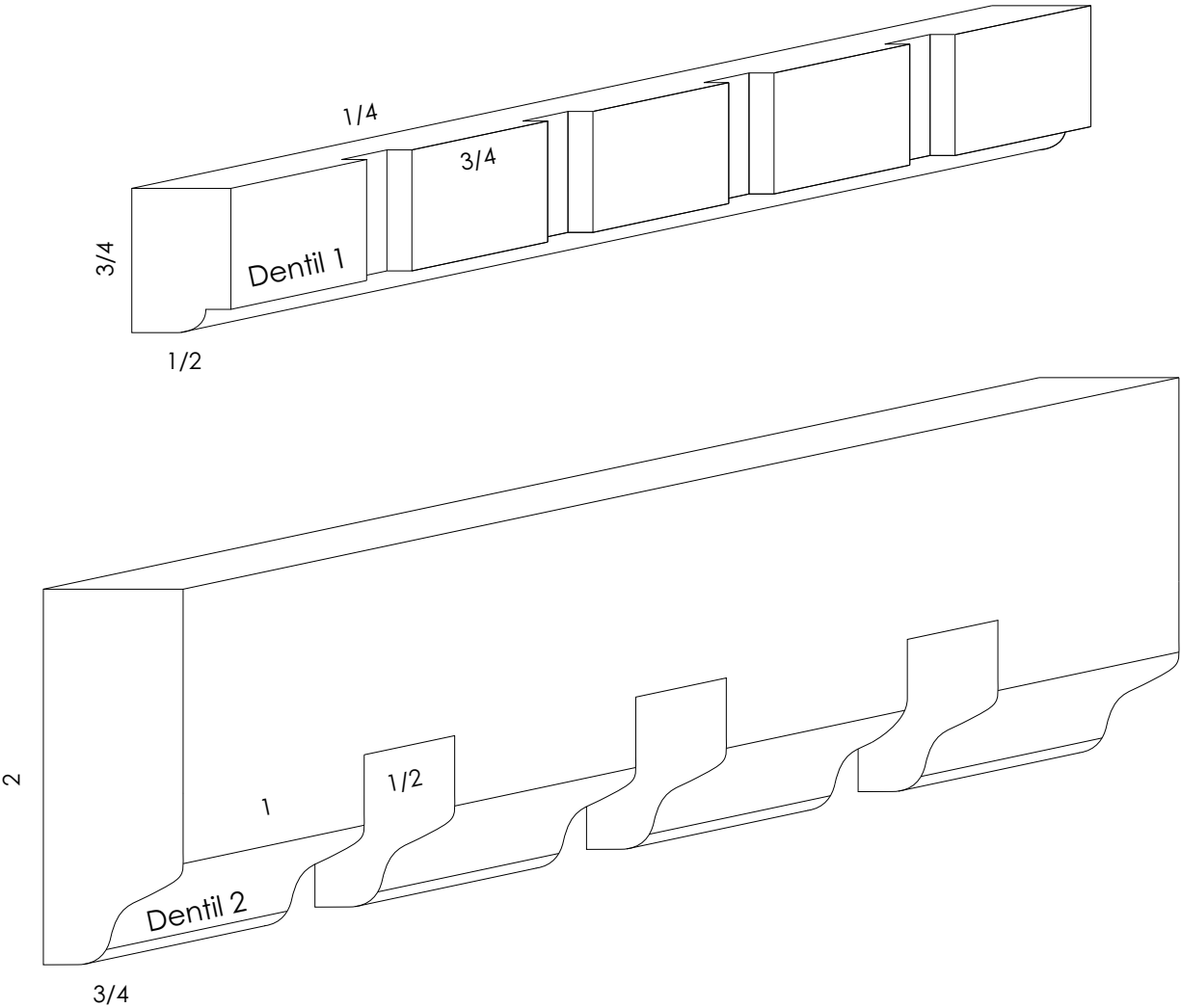

Base and Crown Corner Blocks

Base and crown corner blocks are available in any size to match your base and crown styles.

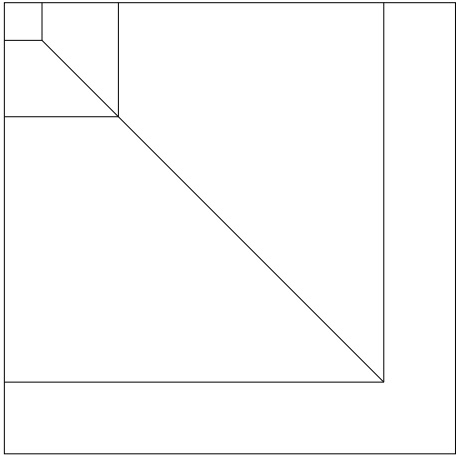
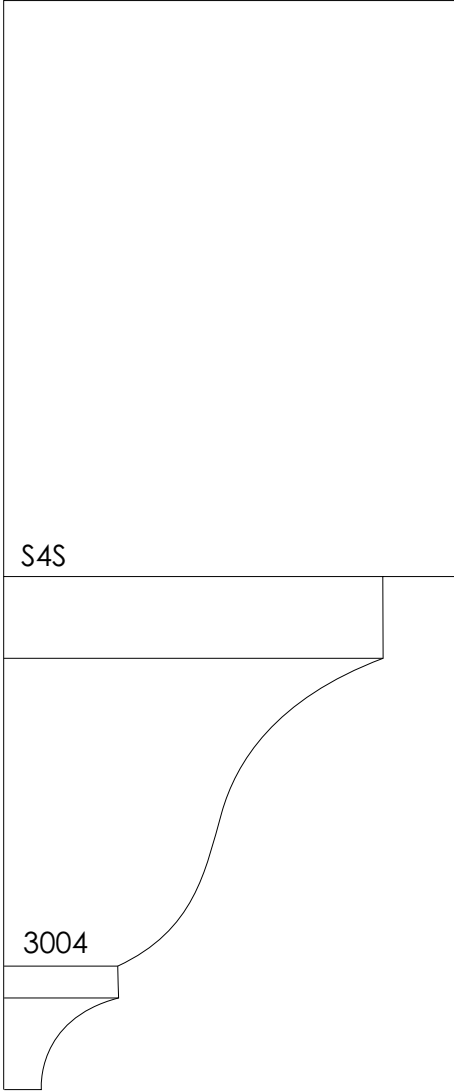

Inside Crown Block

Mid-run and outside-corner crown blocks are also available.



Ogee Profile

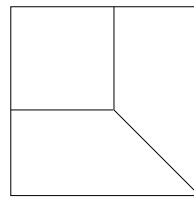

Inside Base Block

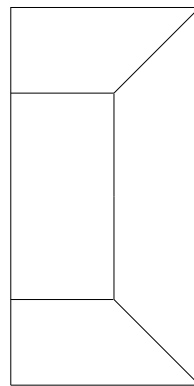

Mid-run Base Block

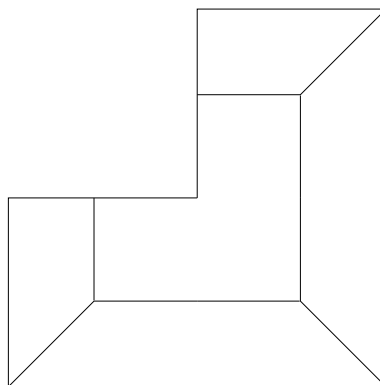

Outside-corner Base Block

Crown Build-up

Crown and baseboards can be combined to create a more dramatic and custom look.

1. 2023 baseboard / 3023 crown
2. 2045 baseboard / 3035 crown
3. 1043 casing / 3046 crown
4. 2043 or 12001 baseboard / 3071 or 13016 crown
5. 2009 baseboard / 3035 crown
6. 2010 baseboard / 3005 crown
7. 2005 baseboard / 3005 crown / 4005 chair rail

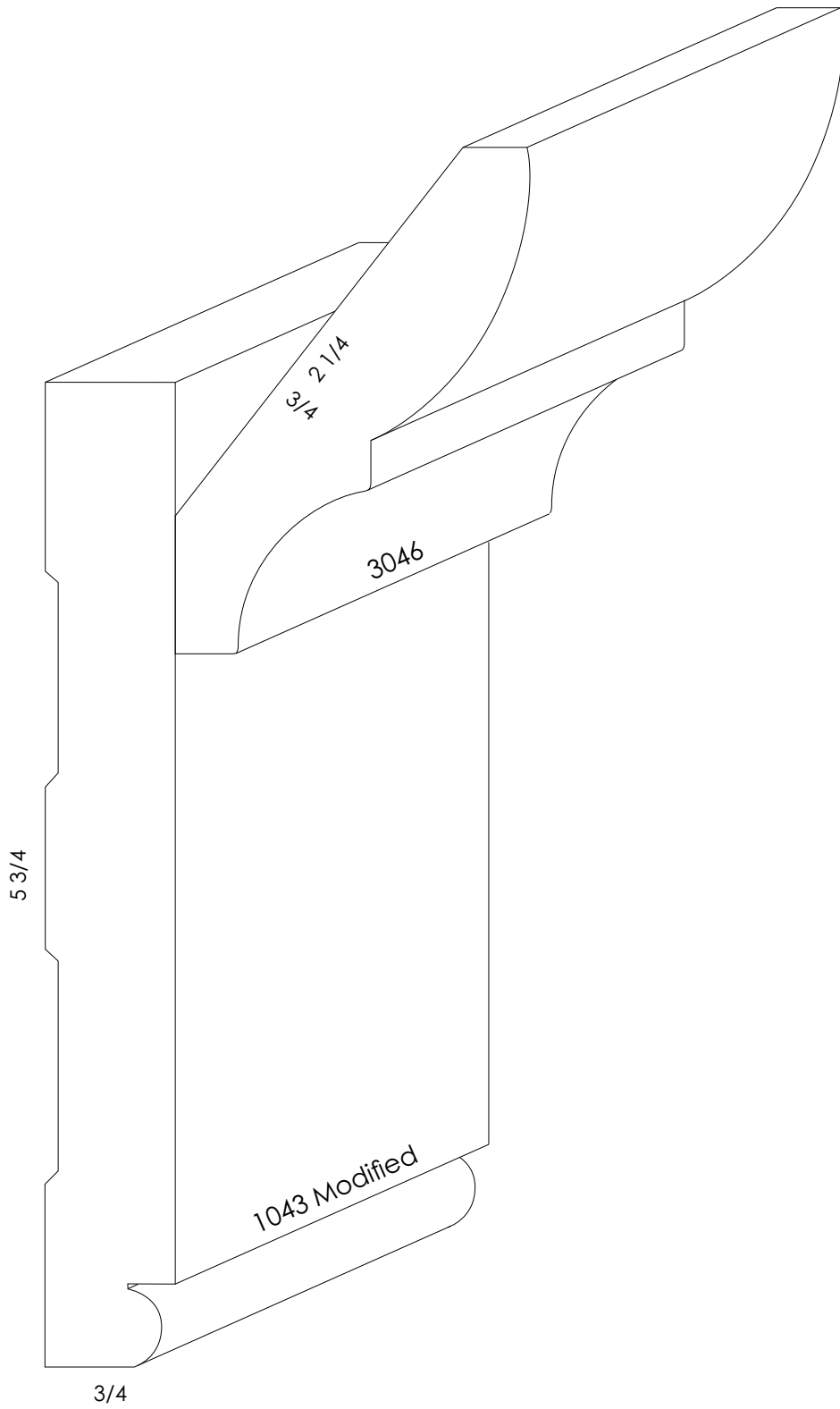

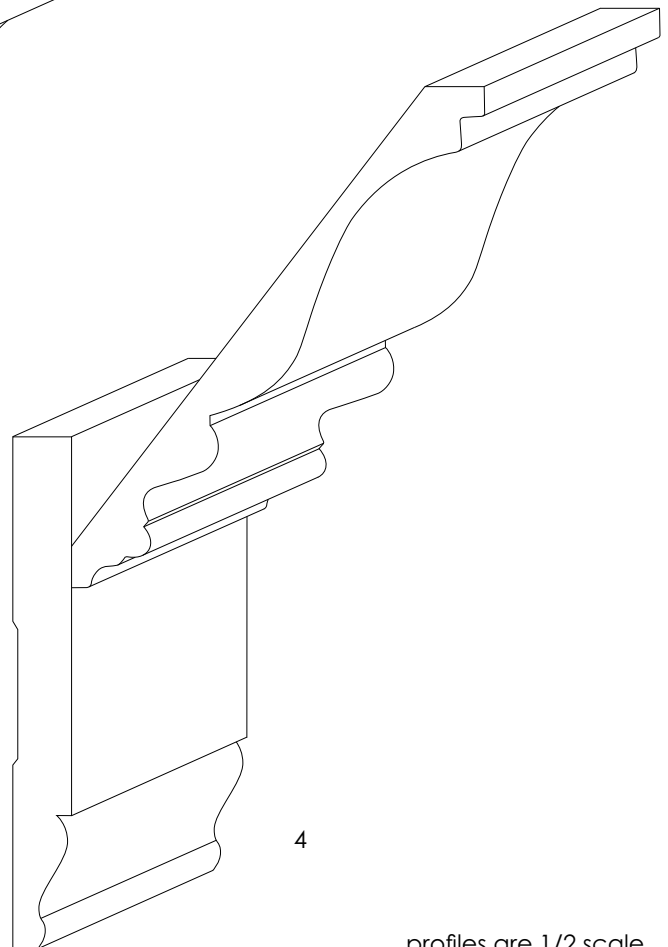
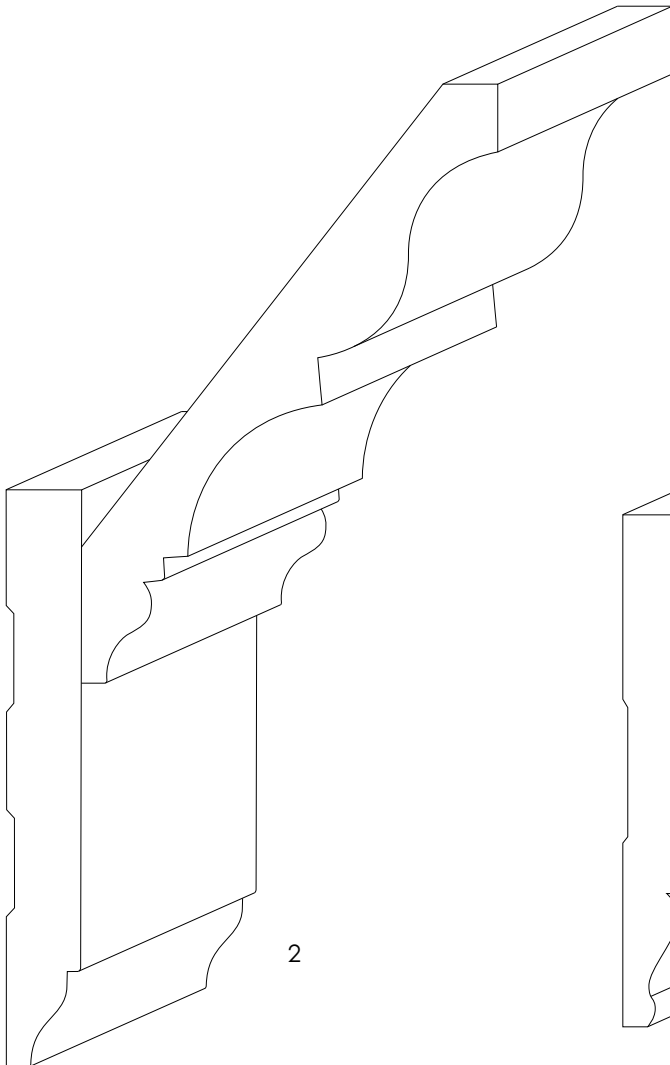
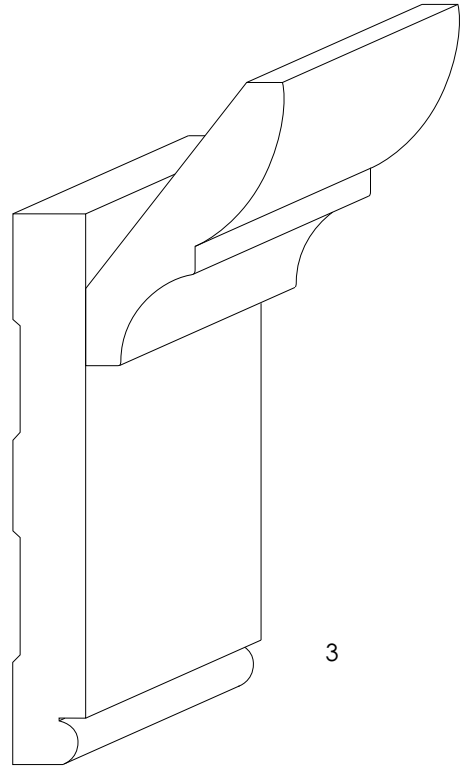
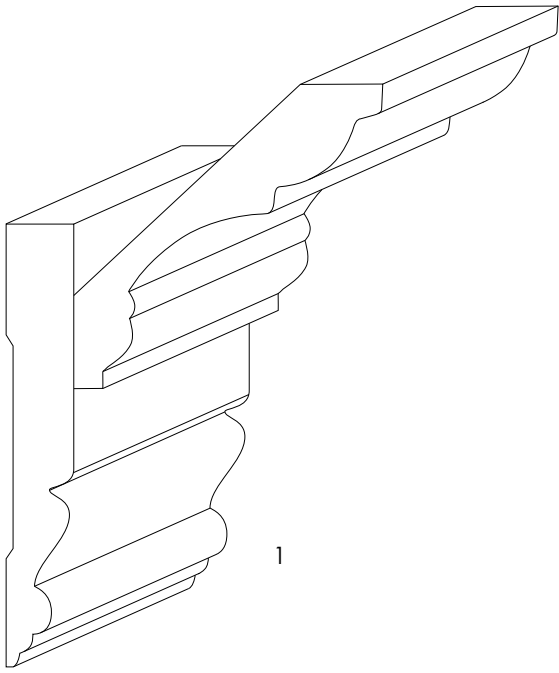

profiles are 1/2 scale

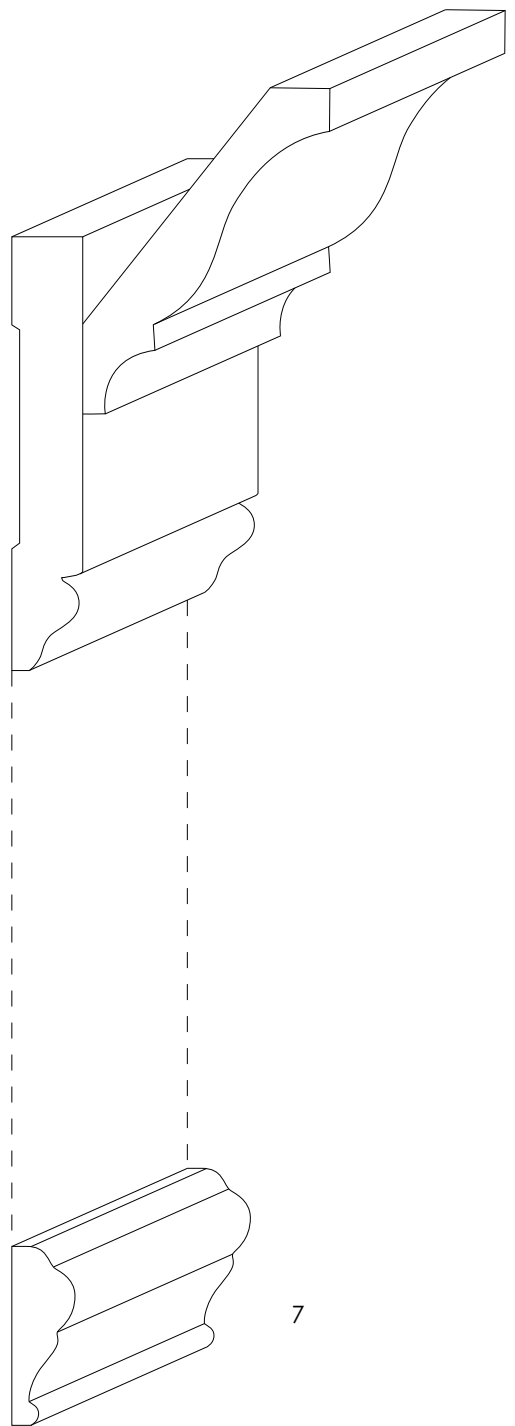
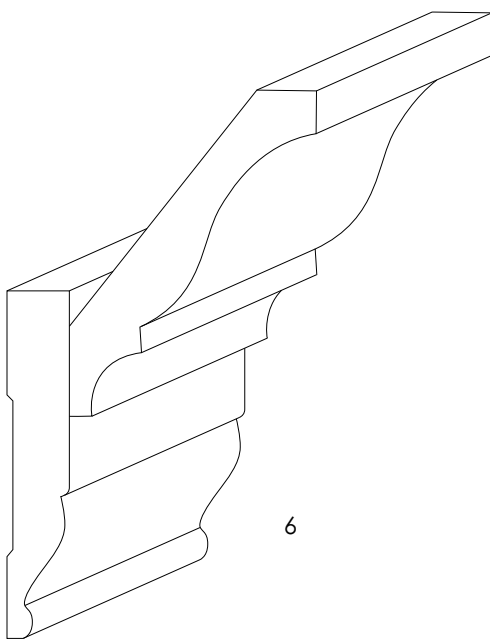
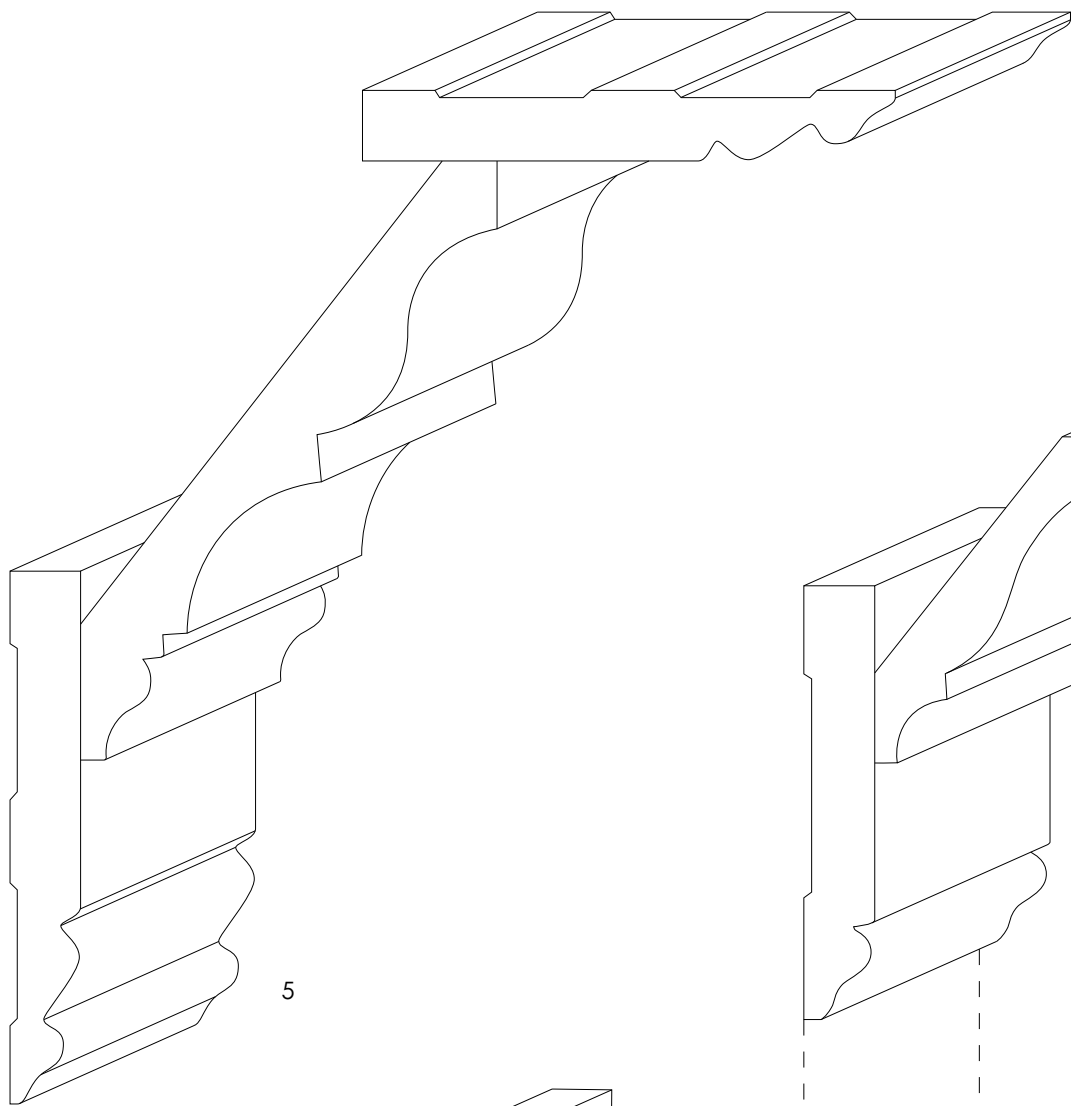

Beams

Beams, when used on ceilings or walls, add depth, dimension, and character to any room.

1. 8079 top corner / 5020 bottom corner / 1 x 8 sides / 1X6 bottom
2. 3001 top corner / 5007 bottom corner / 1 x 4 sides / 1X6 bottom
3. 3005 top corner / 5007 bottom corner / 1 x 6 sides / 1X6 bottom
4. 3005 top corner / 1 x 8 sides / 1X6 bottom

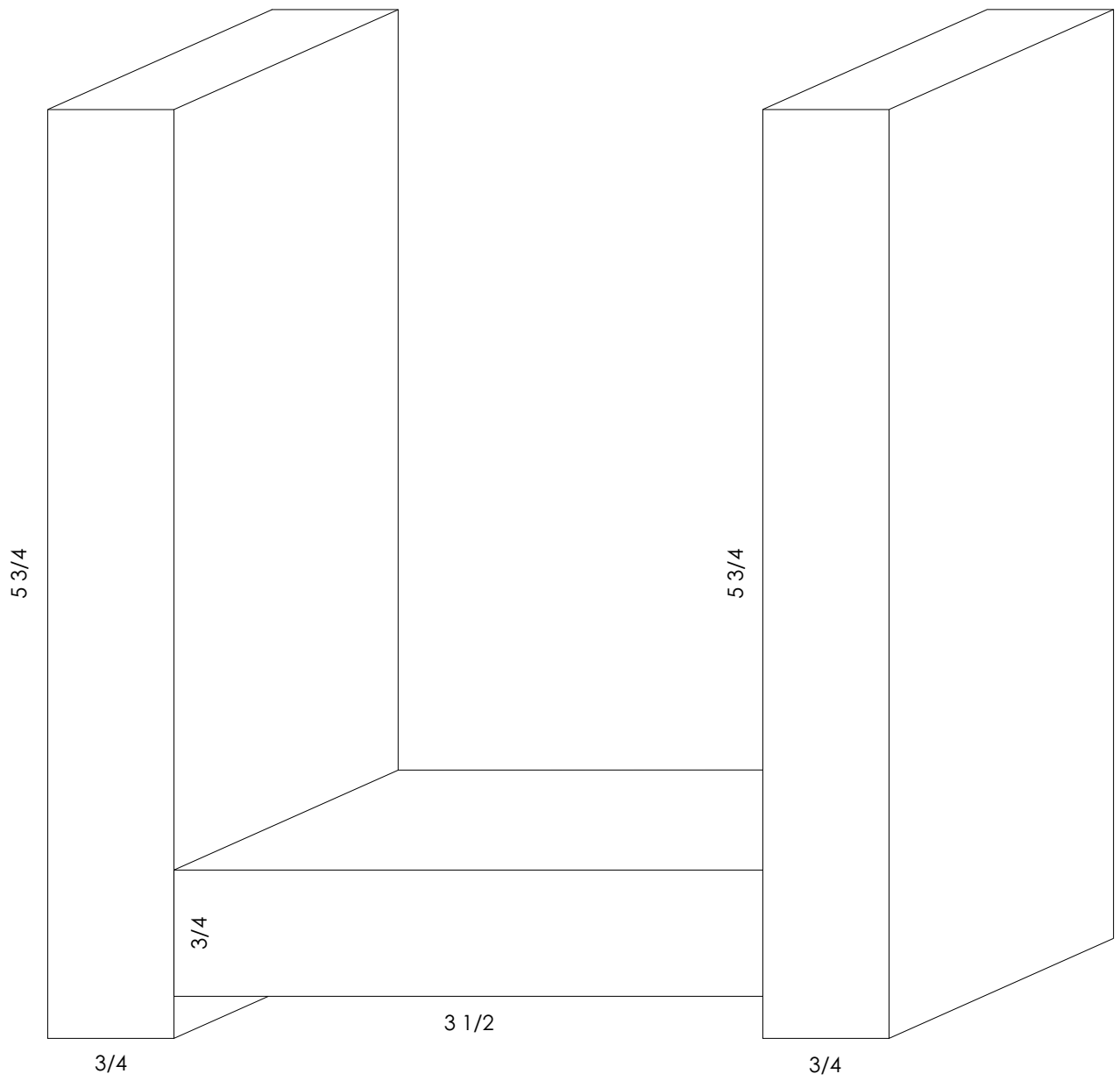

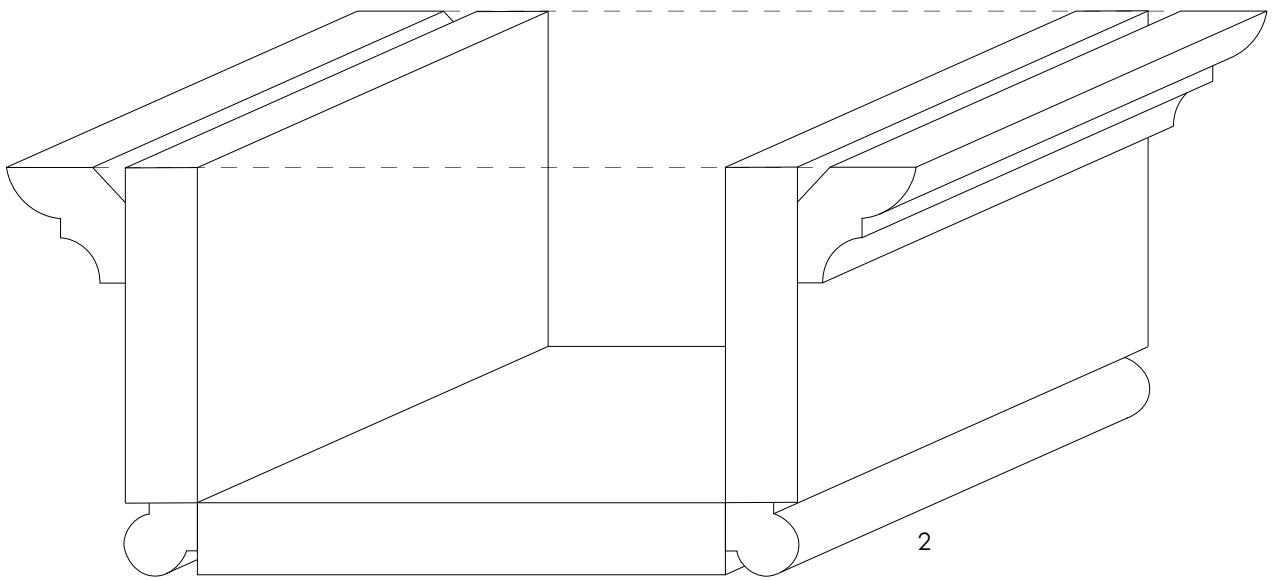
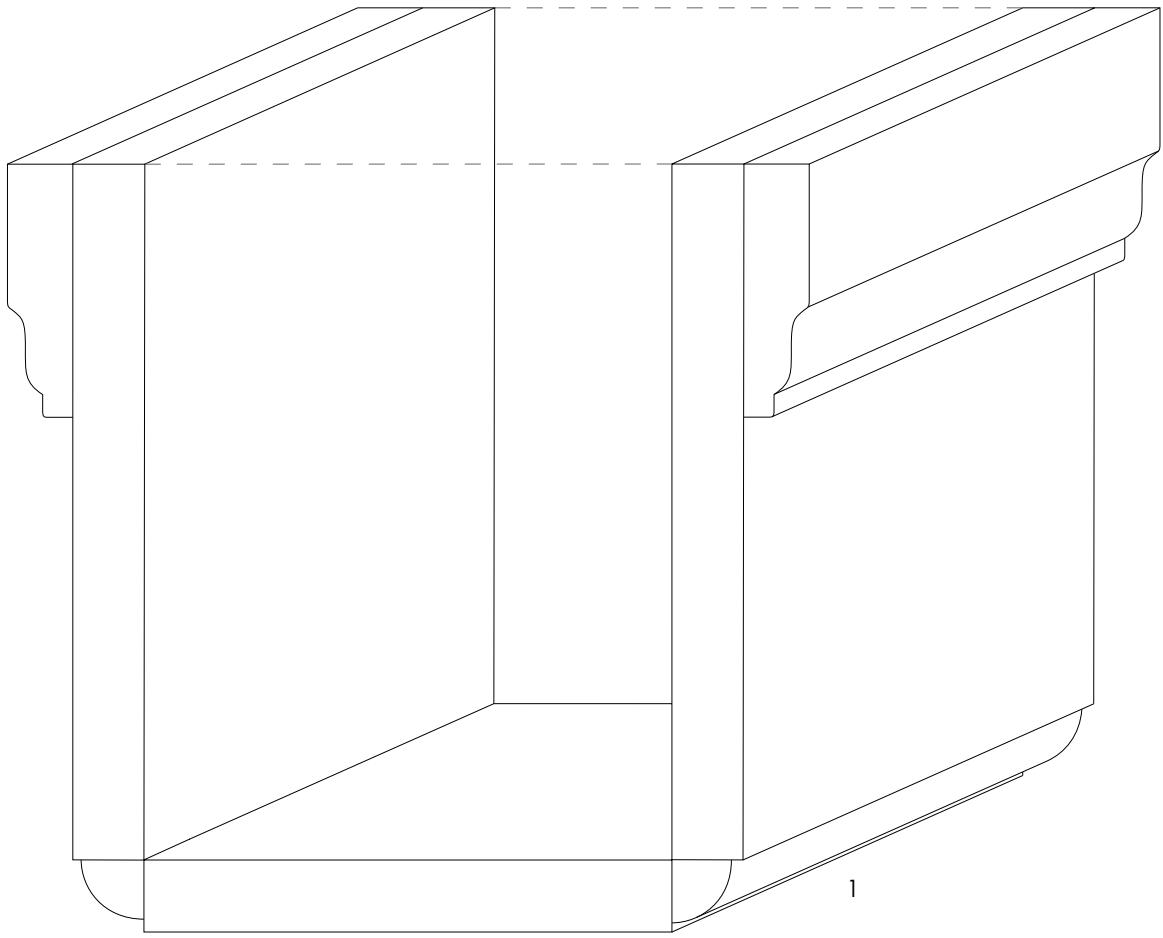

profiles are 1/2 scale

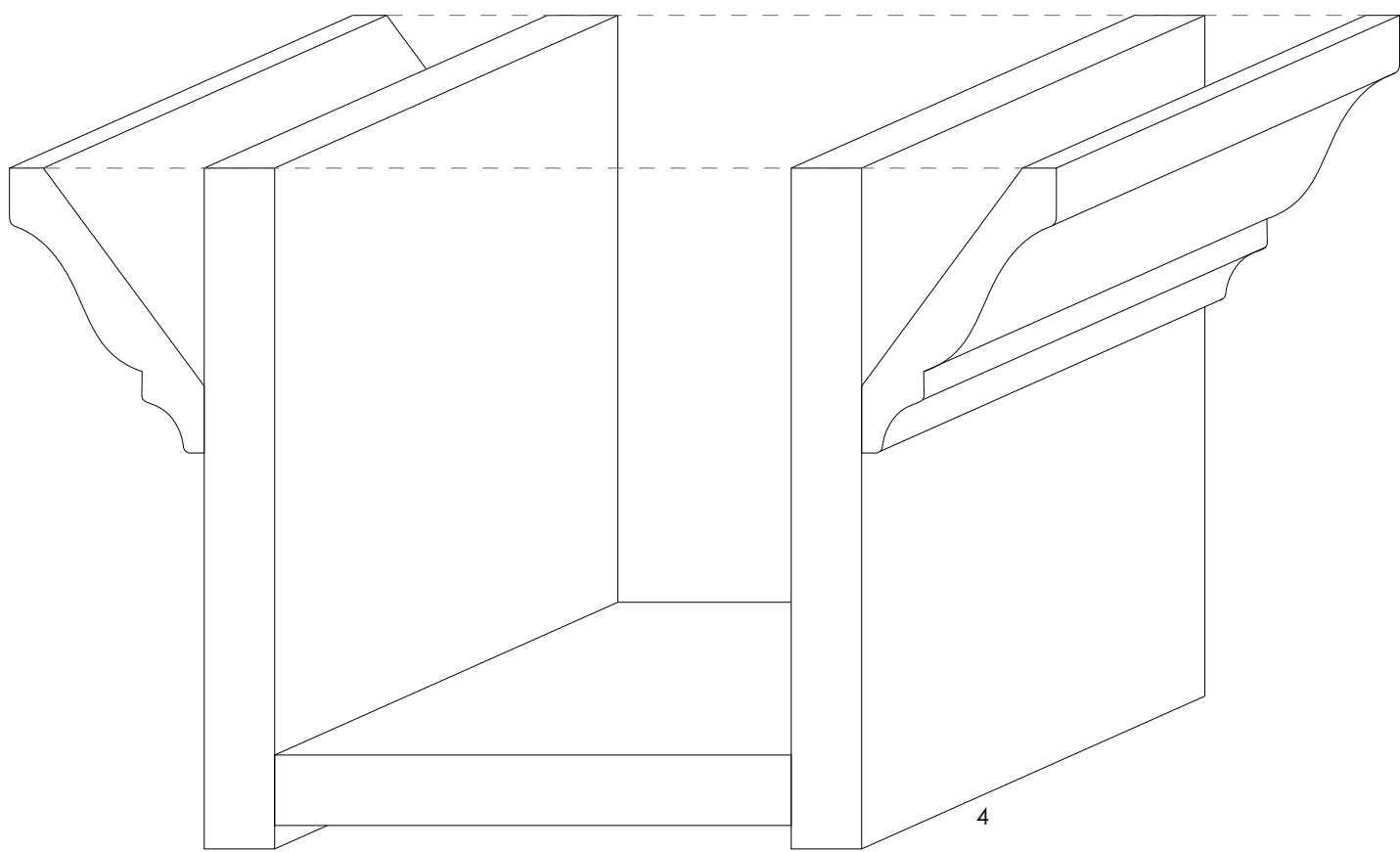
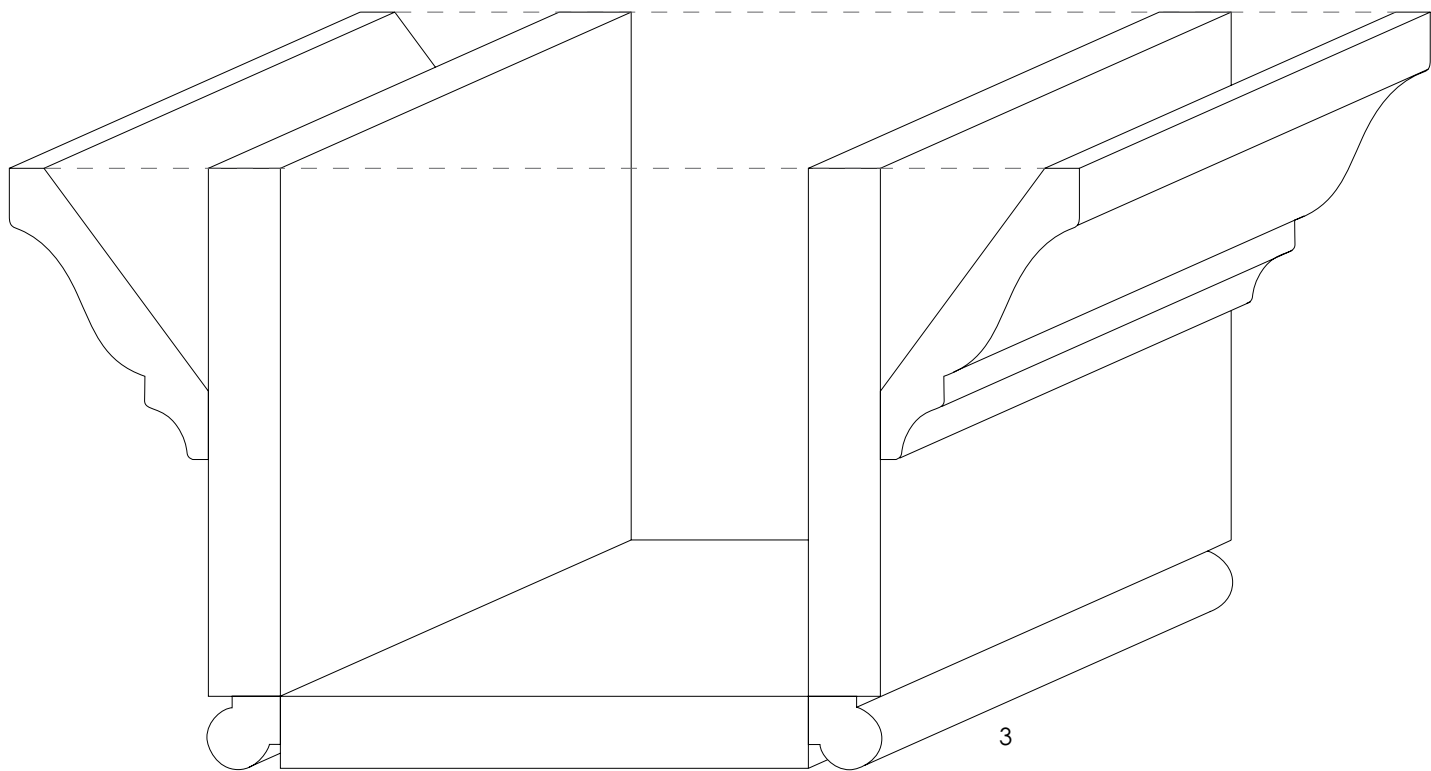

Wainscoting

Wainscoting styles are extremely versatile, accomodating a variety of architectural styles and room configurations and can be combined with short walls, pillars, and pilasters at room openings.

5203 Modified

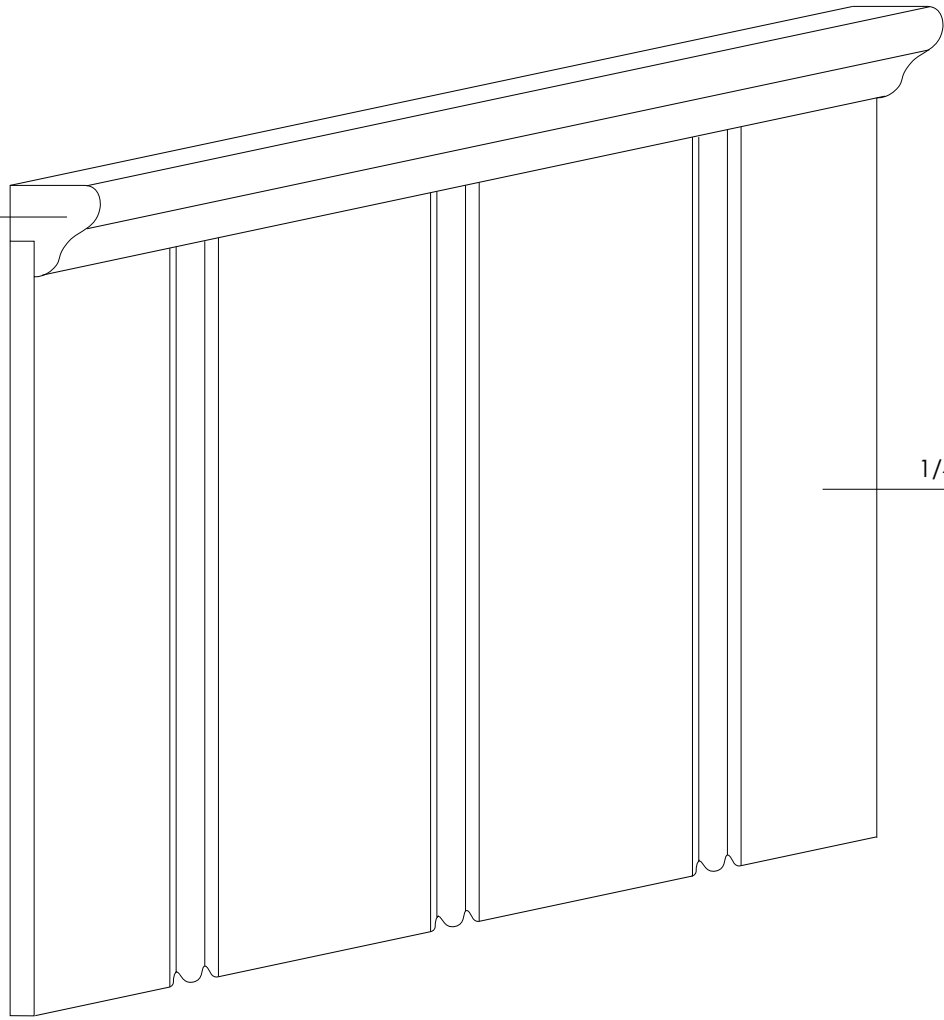

1/4 Beadboard

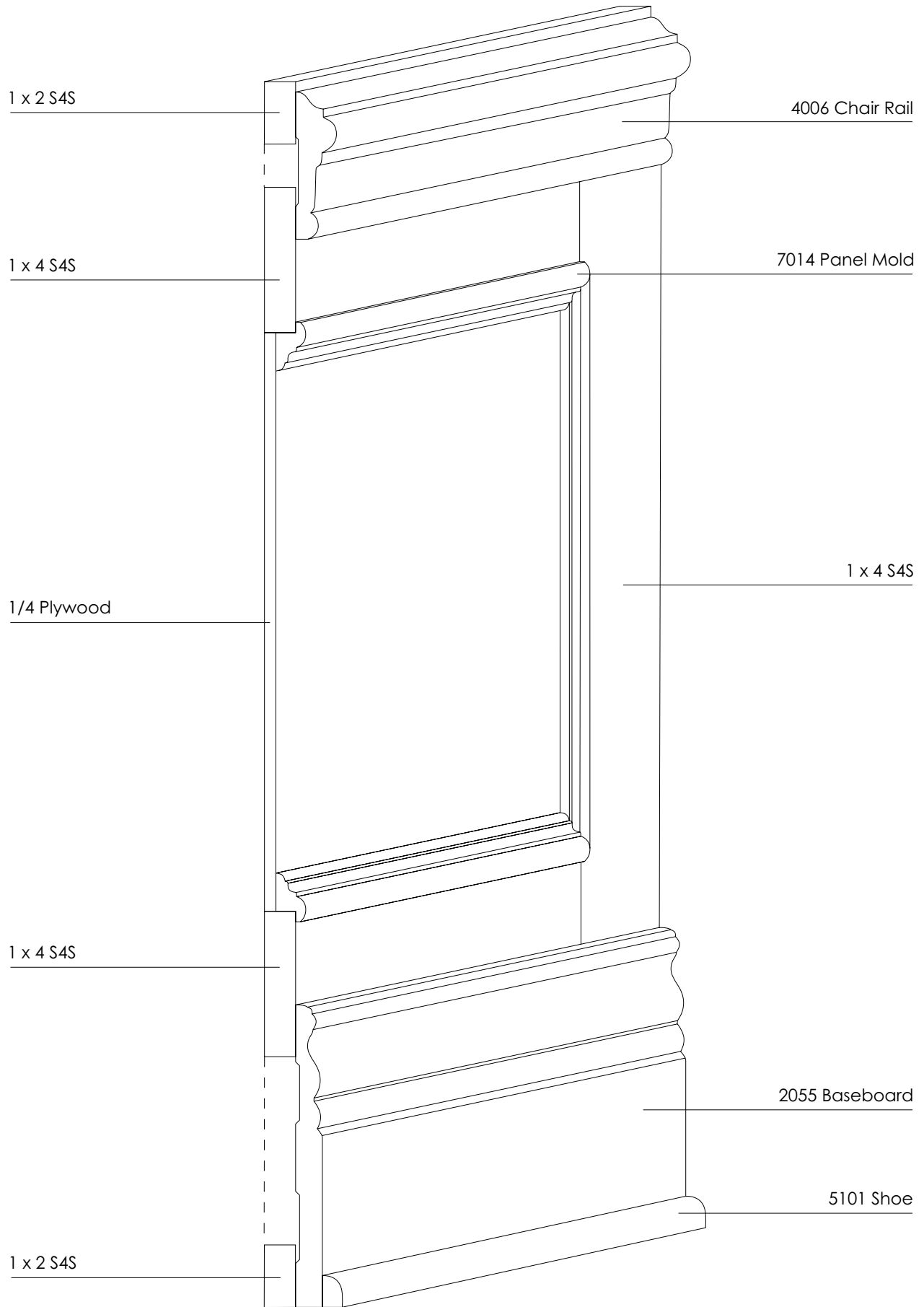

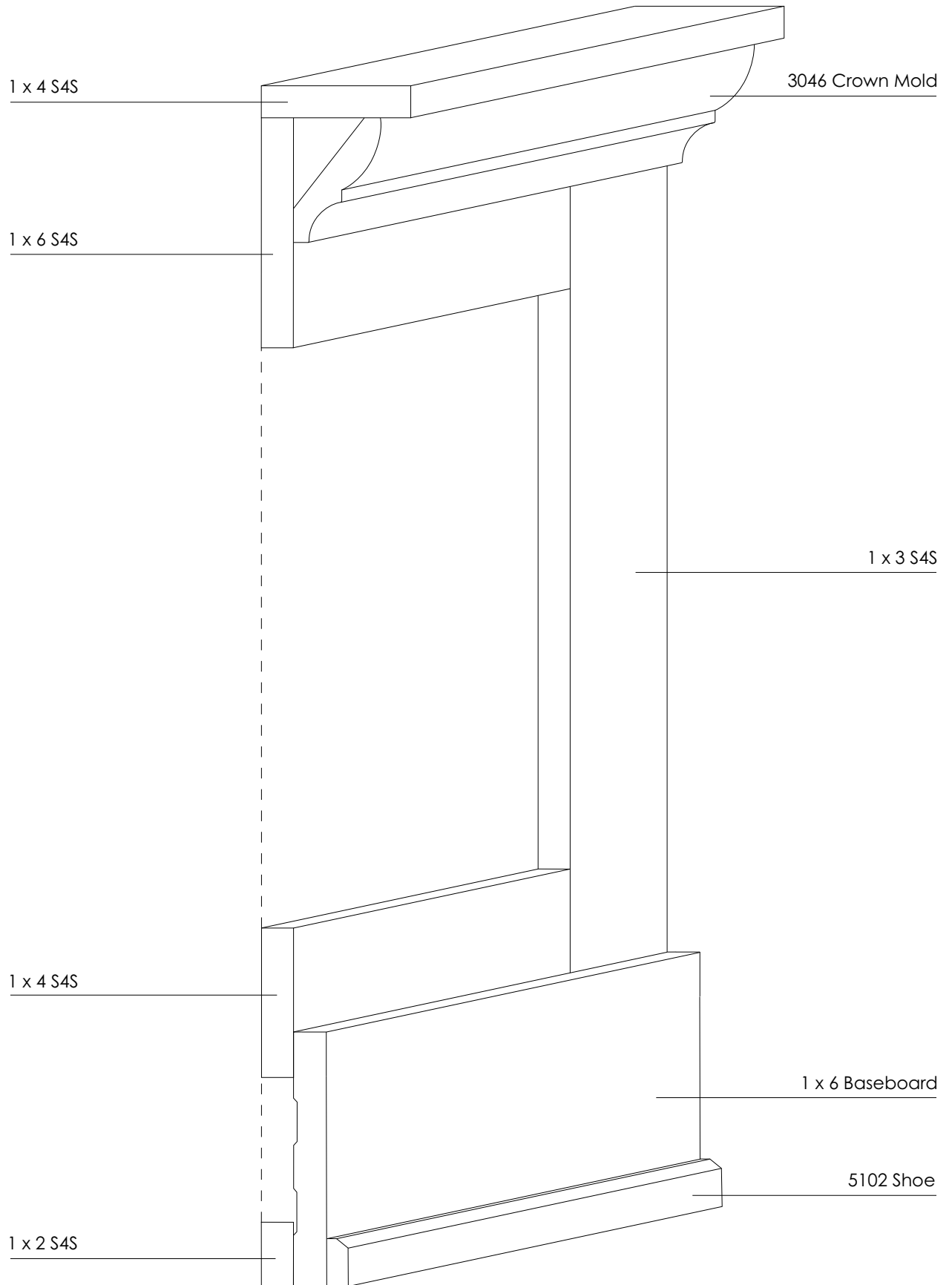

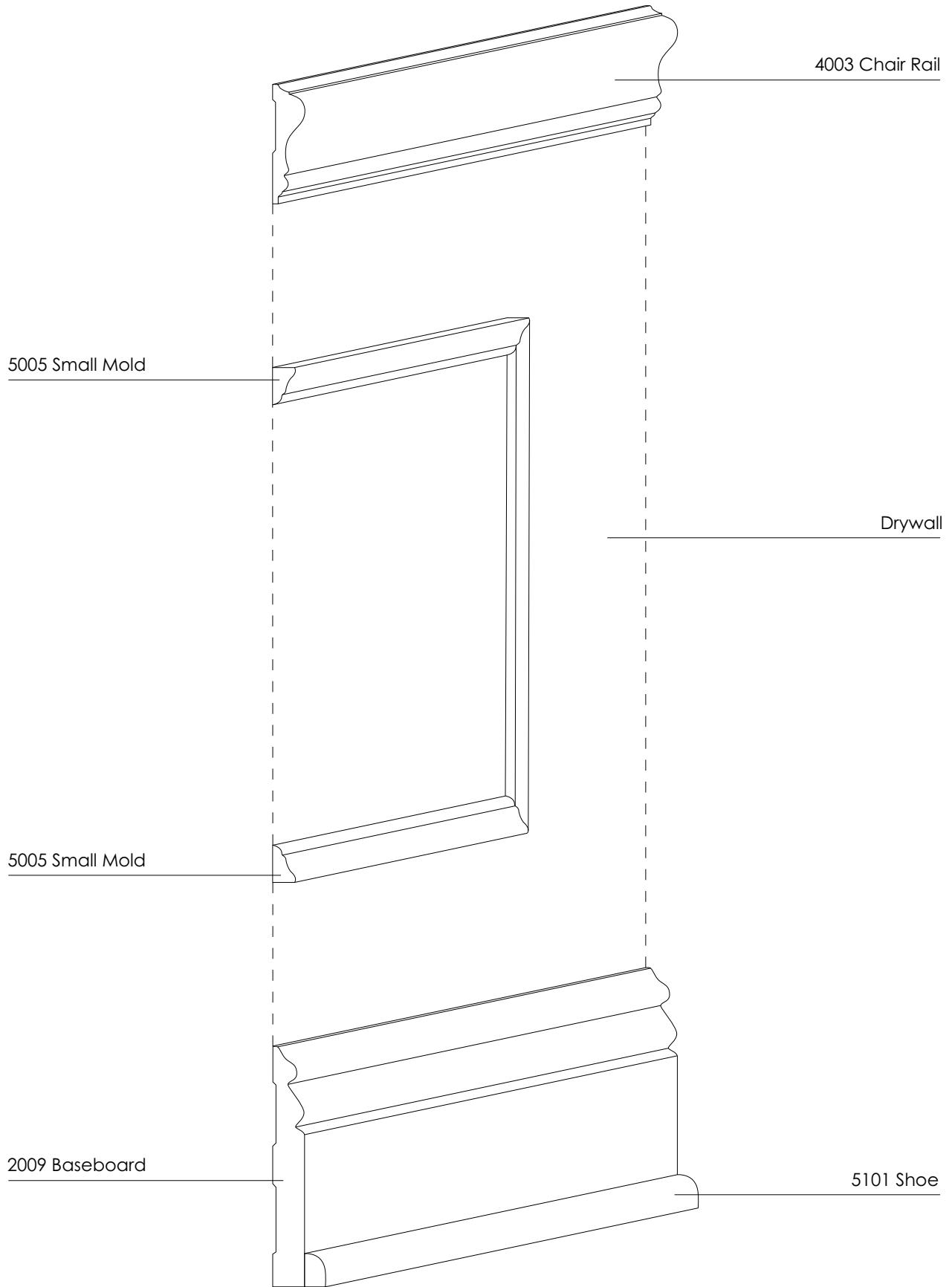

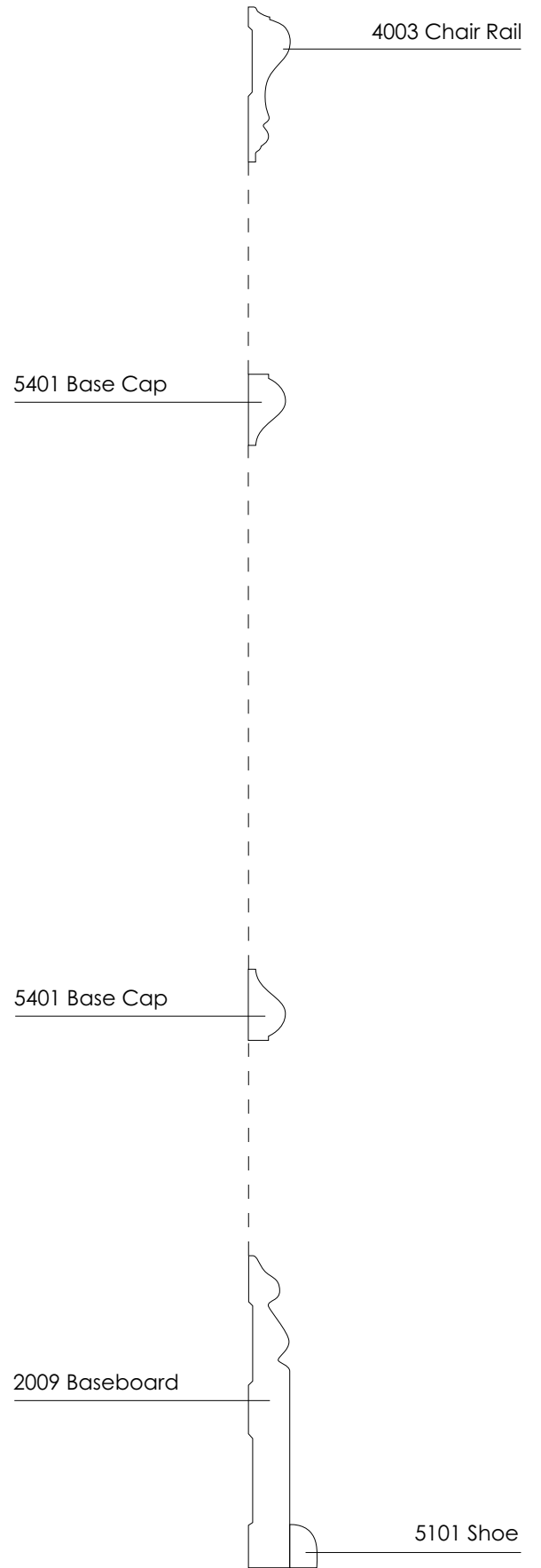
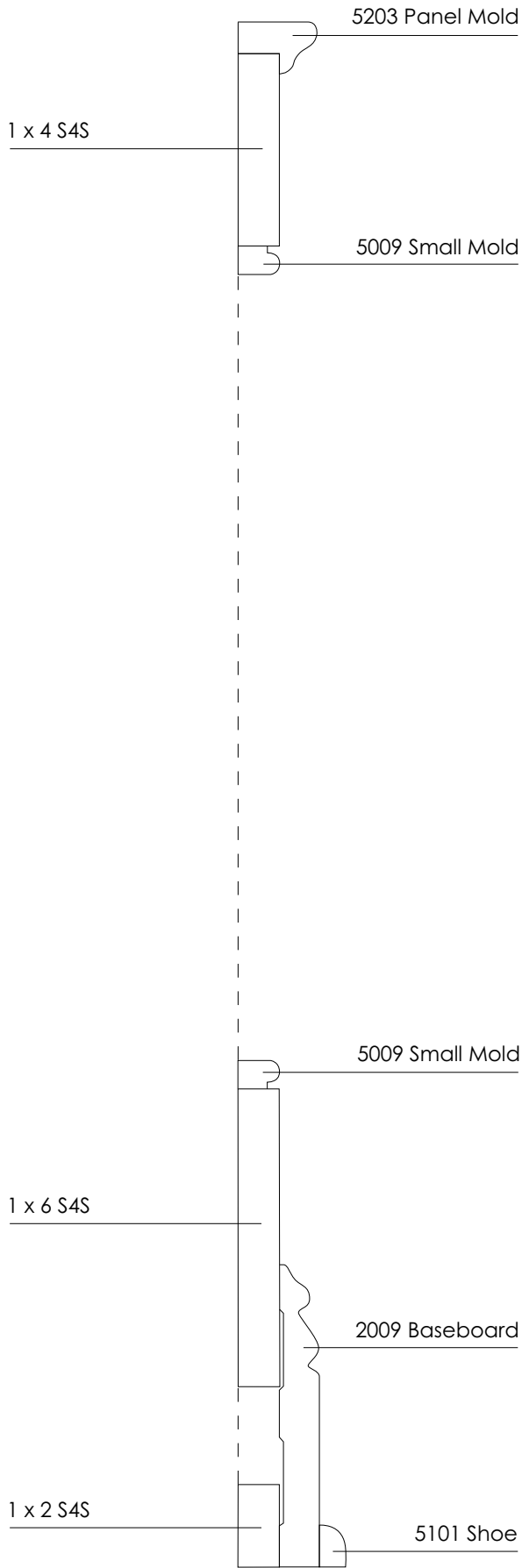

Door and Window Headers

Headers are horizontal elements of casing or built-up mouldings applied to the top of a door or window openings for added decoration.

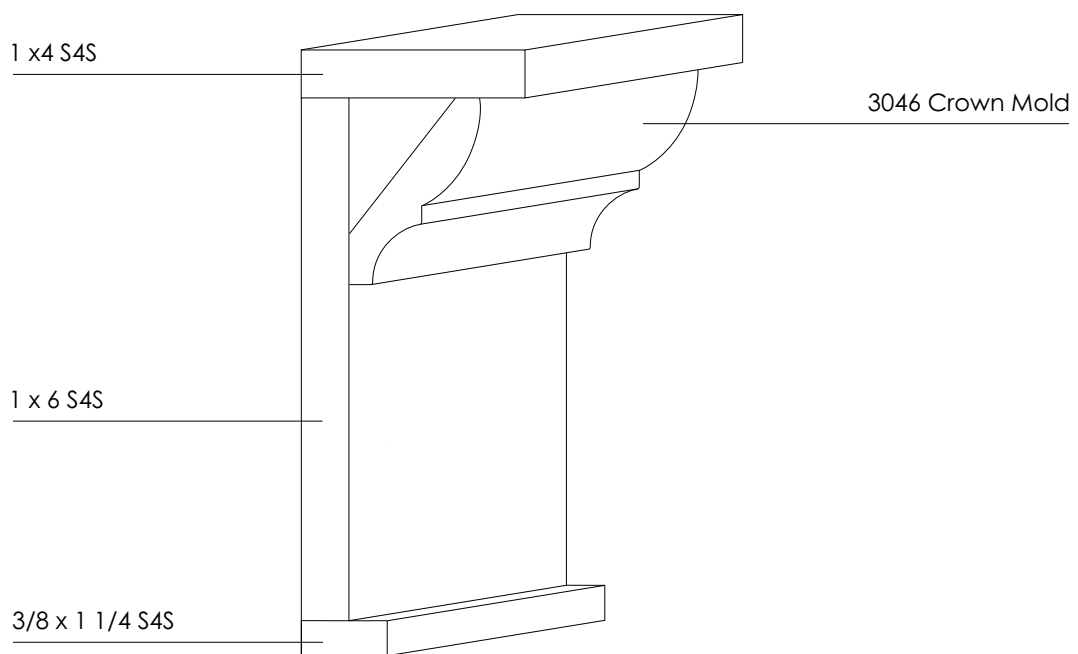
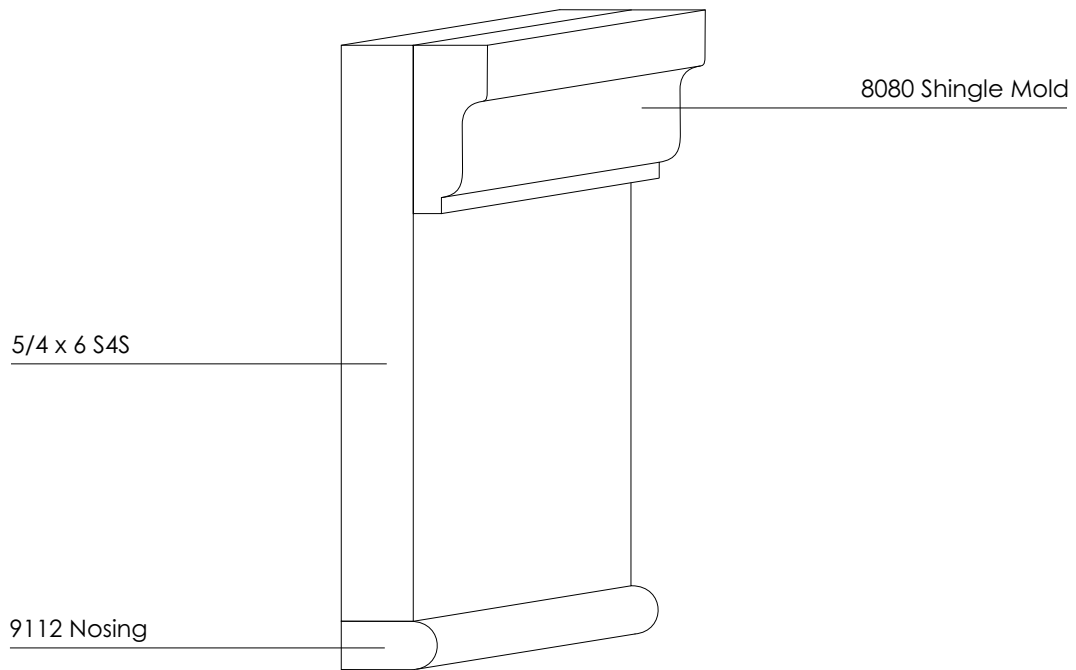

Backband and Casing

Backband added to casing is a way to make a house look more impressive and creates a "heavy trim" appearance.

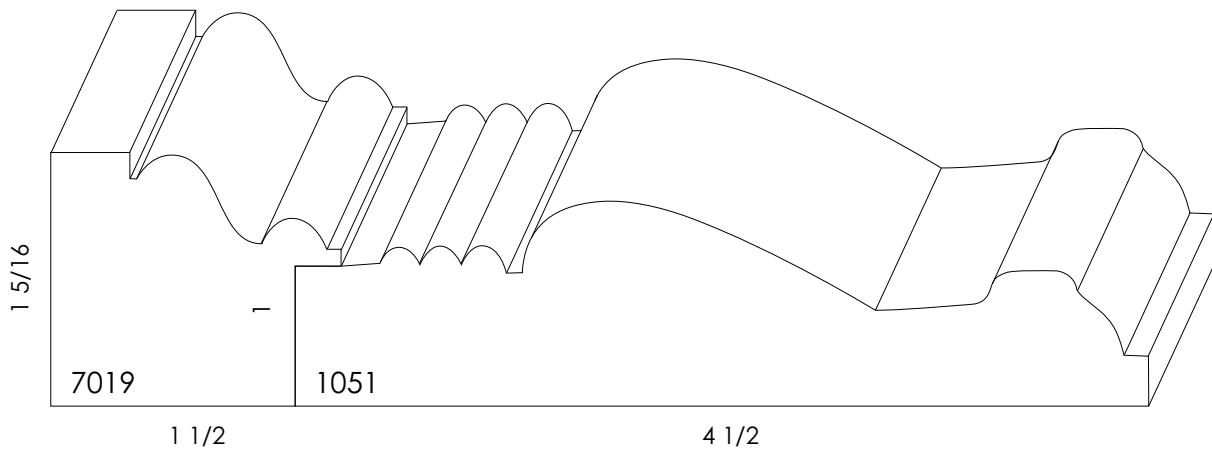
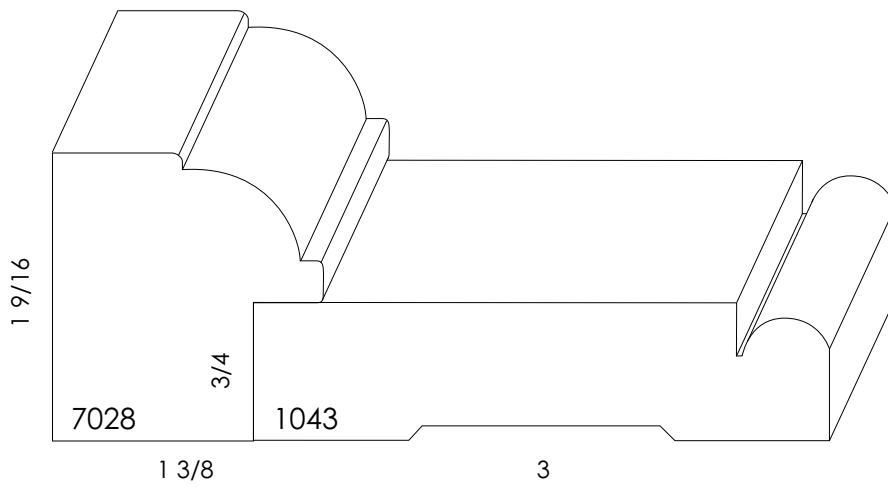

Backband height may be modified to match casing dimensions.

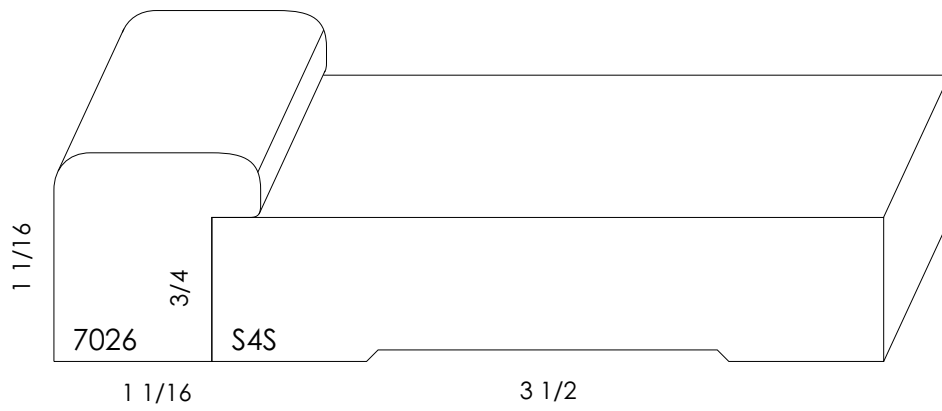
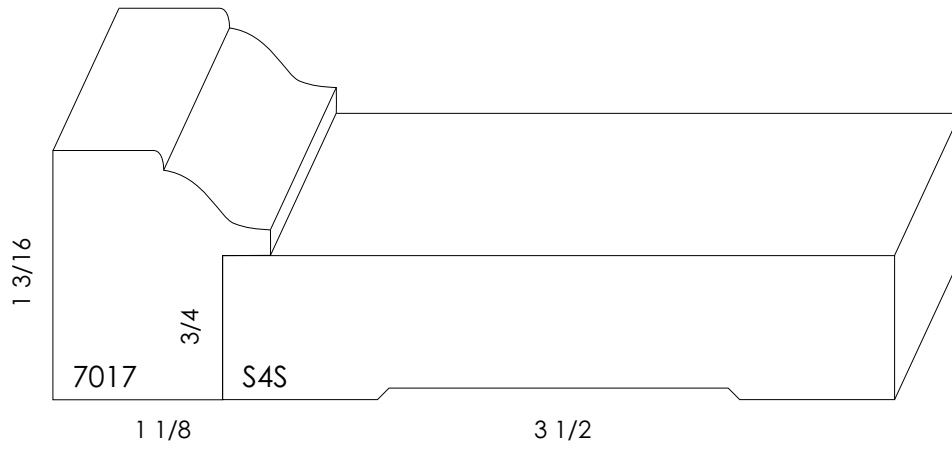
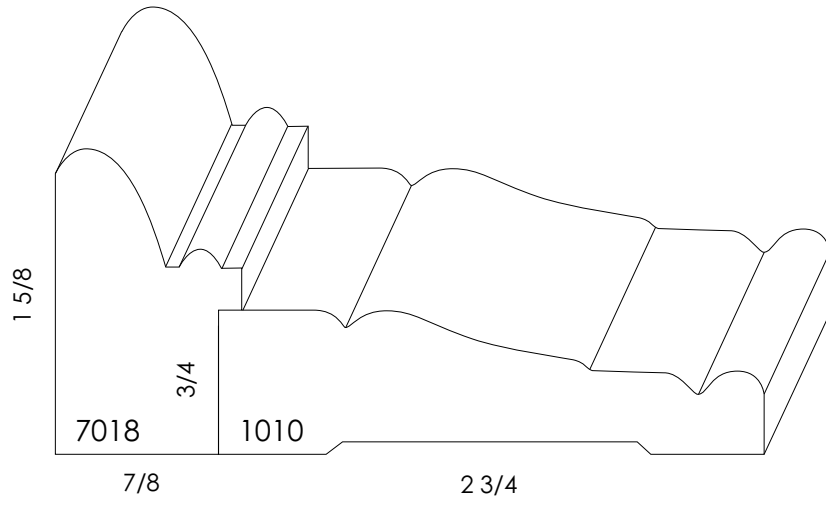

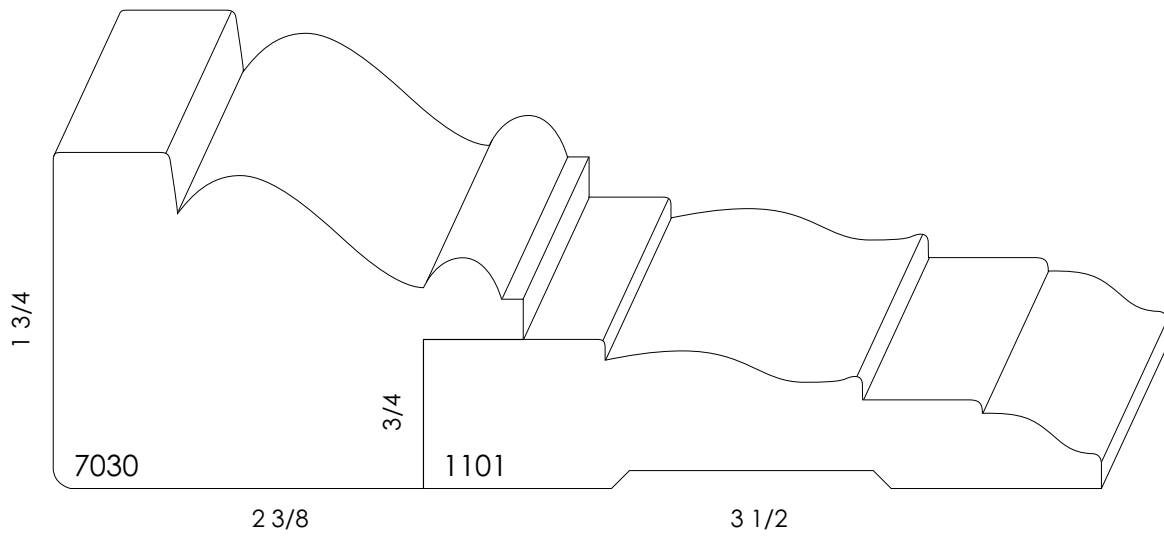
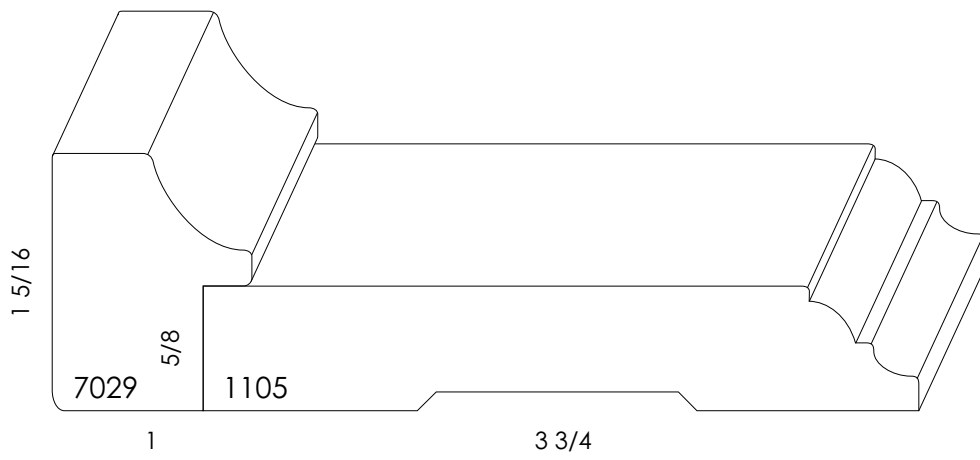
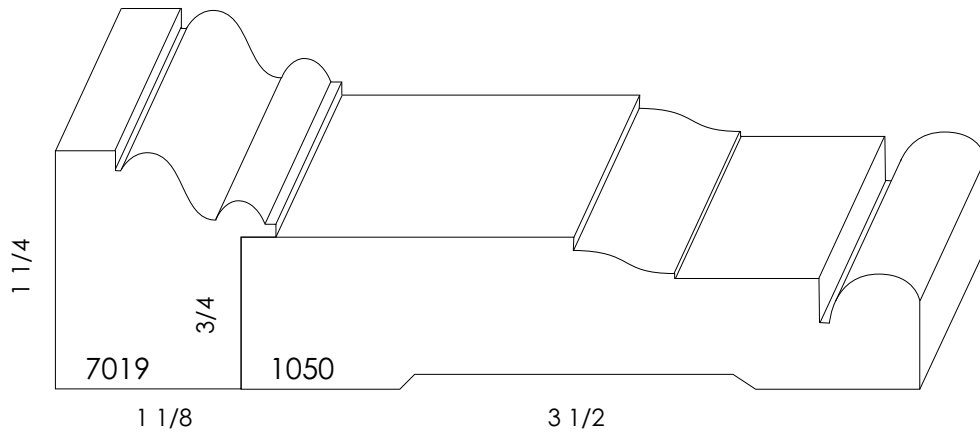

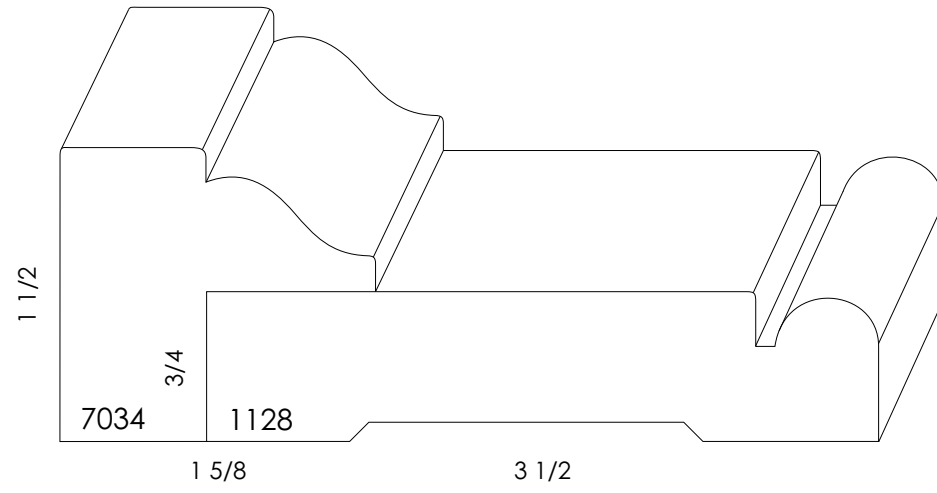
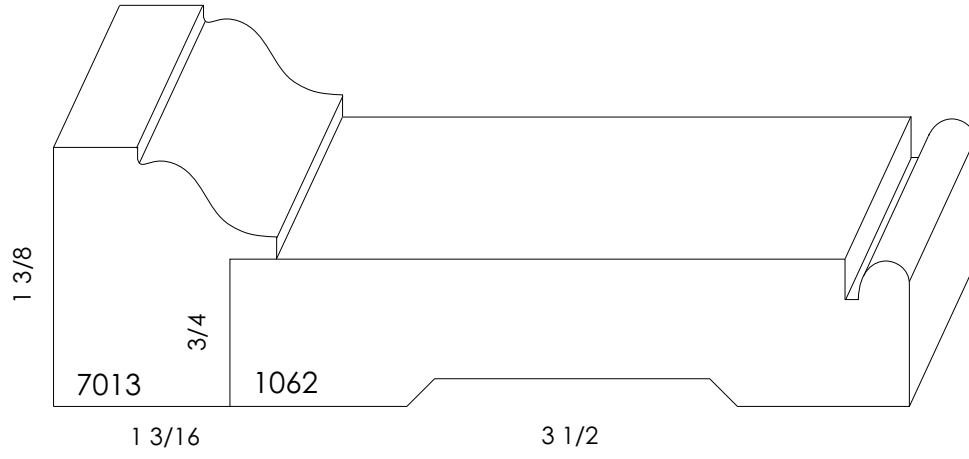

Custom Order Policies

For all non-stock items, a 10% production charge will be added for all specified lengths.

Orders must be paid upon delivery or pickup unless an account has been set-up.

Custom profiles may be over-run by 10%.

All custom millwork is non-returnable except for the amount that exceeds 10% more than our take-off.

For all non-stock profiles, a set-up charge will be assessed for production runs less than 499 lineal feet. No set-up charge is required for orders exceeding 500 lineal feet.

There is a minimum tooling and set-up charge of \$150 for all new profiles. Tooling charges are based on profile size and complexity.

A deposit is required at the time the order is placed for all custom work.

Return Policies

A 15% restocking charge will be applied to all returns.

We only accept returns on items that we carry in stock.

All returns must be accompanied by a receipt.

Damaged, soiled, cut, or altered items are not returnable.

Goods are not returnable after 45 days.

Any shortages in orders must be reported within one working day from pick-up or delivery.

Defect items must be returned within 30 days from delivery.

All returns are subject to our approval.

Because wood is a natural product, we are not responsible for variation in color and mineral stains that may occur.

Any defects must be reported before staining, cutting, or installation.

Warranty policies

Sealing and finishing should be done as soon as possible to maintain wood stability.

All wood products must be maintained under stable temperature and humidity conditions to remain under warranty.

Do not expose wood to rain or snow as water spots could show up after finishing voiding the warranty.

Do not expose wood to extremely high, low, or fluctuating humidity. A relative humidity of 20-60% is ideal.

Wet or damp concrete, plaster, and drywall can transmit moisture to unfinished wood which could lead to swelling, joint separation or warpage and will not be covered under warranty.

Excessive heat, dryness, or sudden temperature changes can cause twisting, cupping, or warping and will not be covered under warranty.

Shipping policies

Our driver will not carry any material into the house.

All material will be unloaded and placed into the garage.

If the house or garage is locked, please give us the key location or the lockbox combination.

We do not require anyone to be at the delivery site as long as there is access to the garage. If there is no access from the driveway, then we require someone to assist to carry materials from the street.

All material to be returned must be placed in the garage.

UPS shipping and handling charges are non-refundable.

Glossary of Moulding Terms

Back Band - Rabbeted moulding surrounding the outside edge of casing

Base - Moulding applied where floor and walls meet, forming a visual foundation

Base Cap - Decorative moulding installed flush against the wall and top of an S4S baseboard

Cap - Upper piece of an entrance, wainscoting, partition, or pilaster

Cased Opening - An interior opening without a door that is finished with jambs and trim

Casing - Moulded or surfaced-four-sided pieces of various widths and thicknesses for trimming out door and window openings

Corner Blocks - Square blocks used in place of mitering the sides and head casing

Cove - Moulding with a concave profile used at corners, particularly as a ceiling cornice

Chair Rail Moulding - Wooden moulding placed along the lower part of the wall to prevent damage

Crown - Highest part of built-in or wall, often above eye level, usually the upper trim on interior walls

Dentil Block - A smaller rectangle block which can be spaced closely together in a series or in sequence with moulding and projecting like teeth as used in cornice, front entrances and mantels, and crossheads

Door stops - Moulding nailed to faces of the door frame to prevent the door from swinging through

Hand Rail - Hand support in a stairwell

Hardwood - Botanical group of trees with broad leaves, in contrast to the needle-like leaves of conifers or softwoods; hardwoods are (1) deciduous (shed their leaves in the fall or at the end of each growing season), (2) have shorter-length wood fibers than softwoods, (3) contain cells (vessels) of relatively large diameters (in addition to the wood fibers), and (4) have seed enclosed by an ovary

Jamb - Top and two sides of a door or window frame

Mouldings - Ornamental strips used to decorate a surface, often used to accent or emphasize the ornamentation of a structure and to conceal surface or angle joints

Nosing - Rounded edge of a stair step

Panel Mould - Decorative pattern, originally used to trim out raised panel wall construction. It is most useful fabricated as a frame, surrounding attractive wall coverings for a paneled effect on walls

Rosette / Plinth Block - Rosette is a decorative block in the upper corner of windows and doors. Plinth is the base block which is placed on both sides of the door resting on the floor

Shoe Rail - Primarily used for closed stairs with a curb wall. The shoe rail sits on top of the curb wall and the balusters fit inside the shoe rail. The fillet is cut and pieced between the balusters

Shoe Moulding - Quarter round trim applied at the bottom of baseboard where it meets the floor

Tongue & Groove - Lumber machined to have a groove on one side and a protruding tongue on the other side, so that pieces fit snugly together with the tongue of one fitting into the groove of the other

Wainscoting - Lower interior wall surface (usually 3 to 4 feet above the floor) that contrasts with the wall surface above it

Window Sill - Interior trim member serving as a window frame sill cap



This catalog was printed on 30%
post-consumer recycled paper.

Photography by Jenny Hershberger
Lineart by Stanley Pinchak
Edition: 5.1
Copyright 2008



P.O. Box 15 or 13813 Station Road; Burton, Ohio 44021

440.834.1891 or 800.798.1269 fax 440.834.1893

Monday-Friday 8am-4:30pm, Saturday 8am-12pm

www.mouldingsone.com