



# Mouldings One

Catalogue of Profile Designs







Since 1958, the Hardwood Lumber Company has grown from a small sawmill selling rough lumber, into a large manufacturing facility that produces a wide variety of quality wood products including stair treads, butcher block countertops, brushes and brooms, and hardwood flooring (Sheoga Hardwood Flooring and Paneling Inc.) Mouldings One, a division of the Hardwood Lumber Company, specializes in milling the highest quality custom architectural millwork, along with the distribution of MDF mouldings, interior doors, stair parts, and door hardware.



## Forest Preservation

The Hardwood Lumber Company is committed to preserving the environment through sustainable logging. All domestic wood species that we harvest originate locally and throughout the Northern Appalachian region, where more trees are planted and grown than are harvested. The exotic species are imported from properly managed forests worldwide.

## Wood Heat: A Renewable Energy

Remaining wood byproducts from manufacturing are used to heat our buildings and operate drying kilns. This type of energy is renewable and reduces the need for oil and gas drilling, storage, and transportation to our facility.



Architectural Styles	10-57	Nosing	210-212
Wood Species	58-59	Panel Mold	156-160
		Plinth Block	198-202
Back Band [in stock]	69	Shoe	155
Base [in stock]	63	Shoe Rail and Fillet	172
Base Cap [in stock]	67	Small Mold	153-154
Casing [in stock]	62	Tongue and Groove	203-207
Chair Rail [in stock]	65	Transition Mold	213-215
Outside Corner [in stock]	68	Window Sill	208-209
Cove [in stock]	65		
Crown [in stock]	64	MDF Base [in stock]	221
Door Stop [in stock]	67	MDF Casing [in stock]	220
Handrail [in stock]	68-69	MDF Crown [in stock]	222-223
Nosing [in stock]	71	MDF S4S [in stock]	219
Panel Mold [in stock]	67		
S4S [in stock]	60-61	MDF Base	227-229
Shoe [in stock]	66	MDF Casing	224-226
Shoe Rail and Fillet [in stock]	69	MDF Chair Rail	231
Small Mold [in stock]	66	MDF Crown	230-231
Window Sill [in stock]	70		
		Customized Details and Design Ideas	233
Back Band	173-178	Base and Crown Corner Blocks	236-237
Bar Rail	202	Beams	246-249
Base	104-123	Casing with Backband	266-269
Base Cap	162-165	Crown Build-up	240-245
Casing	72-103	Dentil Mould	239
Chair Rail	149-152	Door and Window Headers	264-265
Outside Corner	166	Entablature	262-263
Cove	148	Mantles	238
Crown	124-147	Rosette and Plinth Blocks	234-235
Door Stop	161	Wainscoting / Wall Paneling	250-259
Handrail	166-172	Wood Column	260-261
MDF	216-229	Policies	270-273
Miscellaneous	179-197	Glossary of Moulding Terms	274-277



## Hardwood and MDF Mouldings

Pages 14-185 showcase most of the profile drawings from our collection (MDF section on pages 172-185). Drawings are accurate, full-scale cross-sections of each moulding.

Most mouldings can be modified for length, width, and thickness. Base caps and panel molds can be designed with a rabbet for recessed paneling or for use as a wainscot cap.

## Radius Designs

Select from the available moulding styles and we will custom fit almost any curving wall, arched entryway, window, or jamb.



asing  
LL SCALE

RING + CAL

OPEN FAMILY

SQUARE ENGAGED COLUMN

For 11"

(Show 1/4" thickness)

174

## Individual Creativity

You are invited to visit our showroom and select from hundreds of wood moulding samples. Any unique, deeply personal vision you have, ranging from traditional to contemporary, can be created from almost unlimited design combinations.

## Custom Mouldings

If you wish to create a moulding that is not found in our collection, our workshop can produce custom tooling to precisely match sketched drawings, architectural blueprints or existing wood samples.



## Architectural Millwork Packages

Using a variety of mouldings from our catalogue, architect David Ellison, of the The D. H. Ellison Company, has created a series stylistically consistent millwork packages to assist designers, builders, and architects working with new homes and restorations. David's hope, along with ours, is to promote the fascinating world of architecture and to inspire your future designs with mouldings as a medium.

To view more of David's exceptional work, we invite you to view his portfolio at [www.dhellison.com](http://www.dhellison.com).

## More Design Ideas

Explore our customized details and design ideas on pages 186-223.

We also offer a CD with a photo gallery of millwork featuring various architectural styles and profile drawings in CAD and JPEG. You can also visit our gallery at [mouldingsone.com](http://mouldingsone.com).

## The *Primer* of Mouldings

The shapes shown are the basic building blocks for architectural mouldings. They are divided into the following geometrical categories: plane, concave, convex, and compound. Among the straight moldings, a small straight surface is referred to as a fascia and a very small straight surface, a fillet. The concave and convex mouldings are typically based on portions of a circle or an ellipse forming the cove, ovolo, echinus, scotia, torus, and conge shapes. Compound mouldings combine these shapes into the cyma, beak, and ogee.

## A Note on Proportion and Scale

To achieve a harmonious visual flow, moulding combinations should be proportionate to their space and internally well scaled.

For further reading about mouldings, proportion and scale, we recommend visiting:

<http://www.s4aa.com/Docs/tradldg.0893.large.pdf>

Straight

Fillet

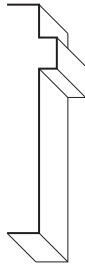

Fascia



Concave

Cavetto

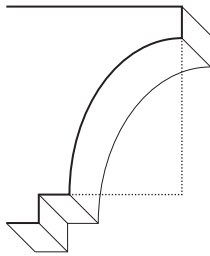

Scotia

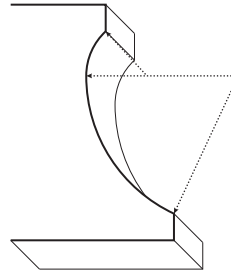

Conge

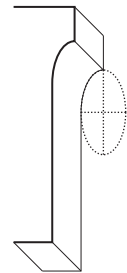

Convex

Ovolo

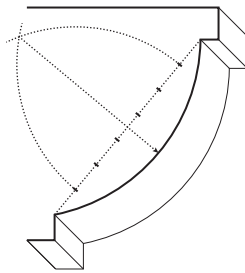

Echinus

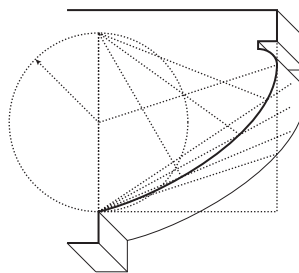

Torus

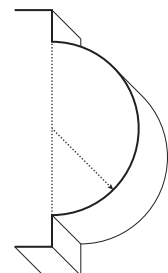

Astragal Bead

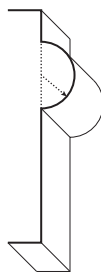

Thumb

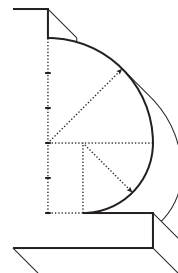

3/4 Bead

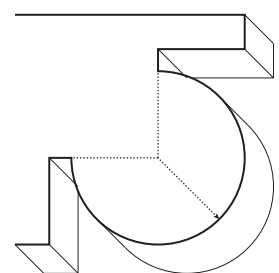

Compound

Cyma Recta

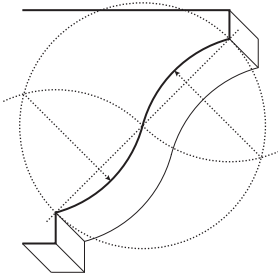

Cyma Reversa

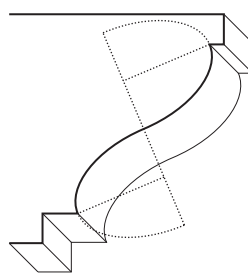

Beak

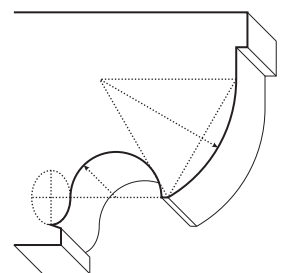

Art Deco

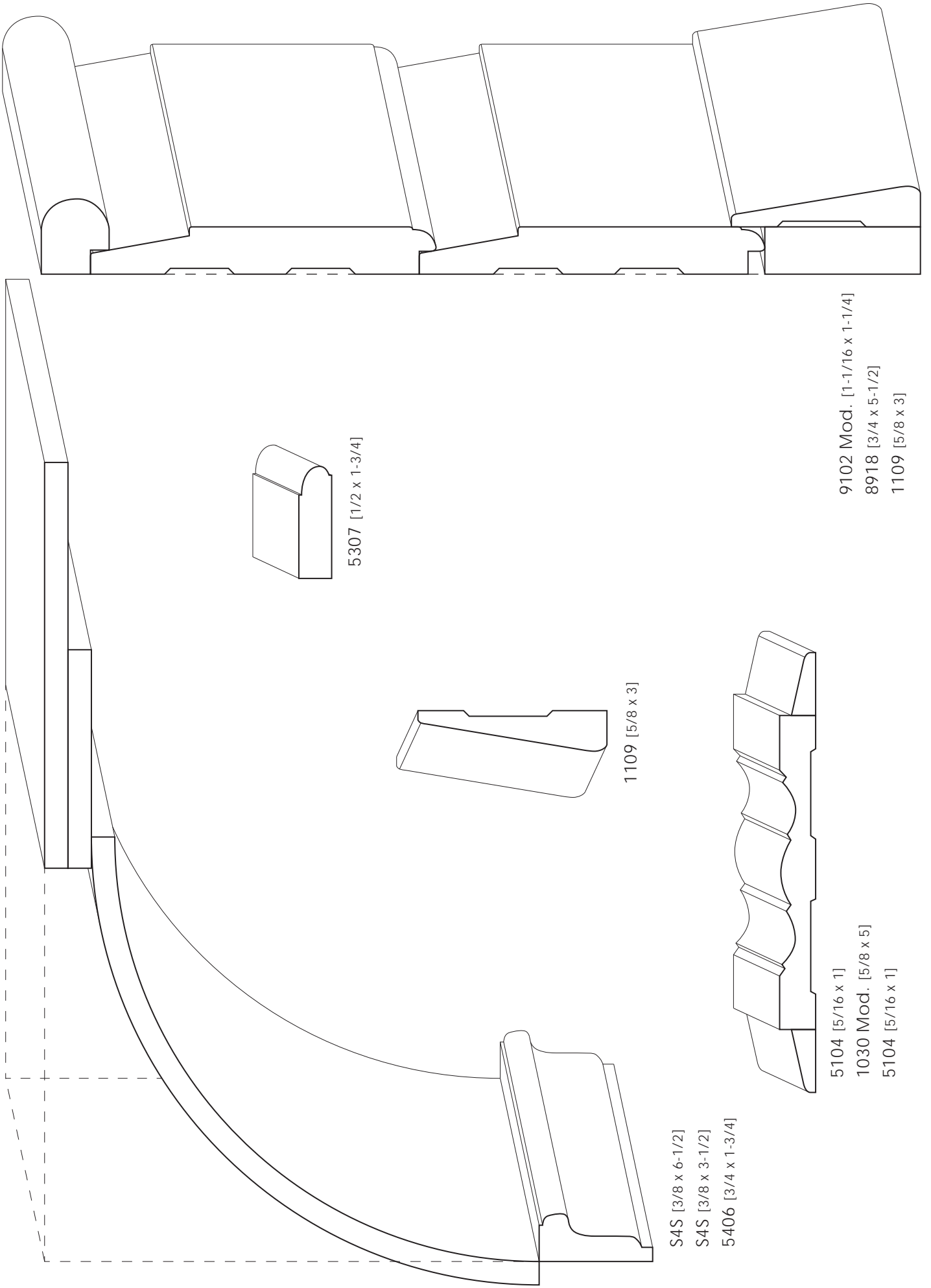

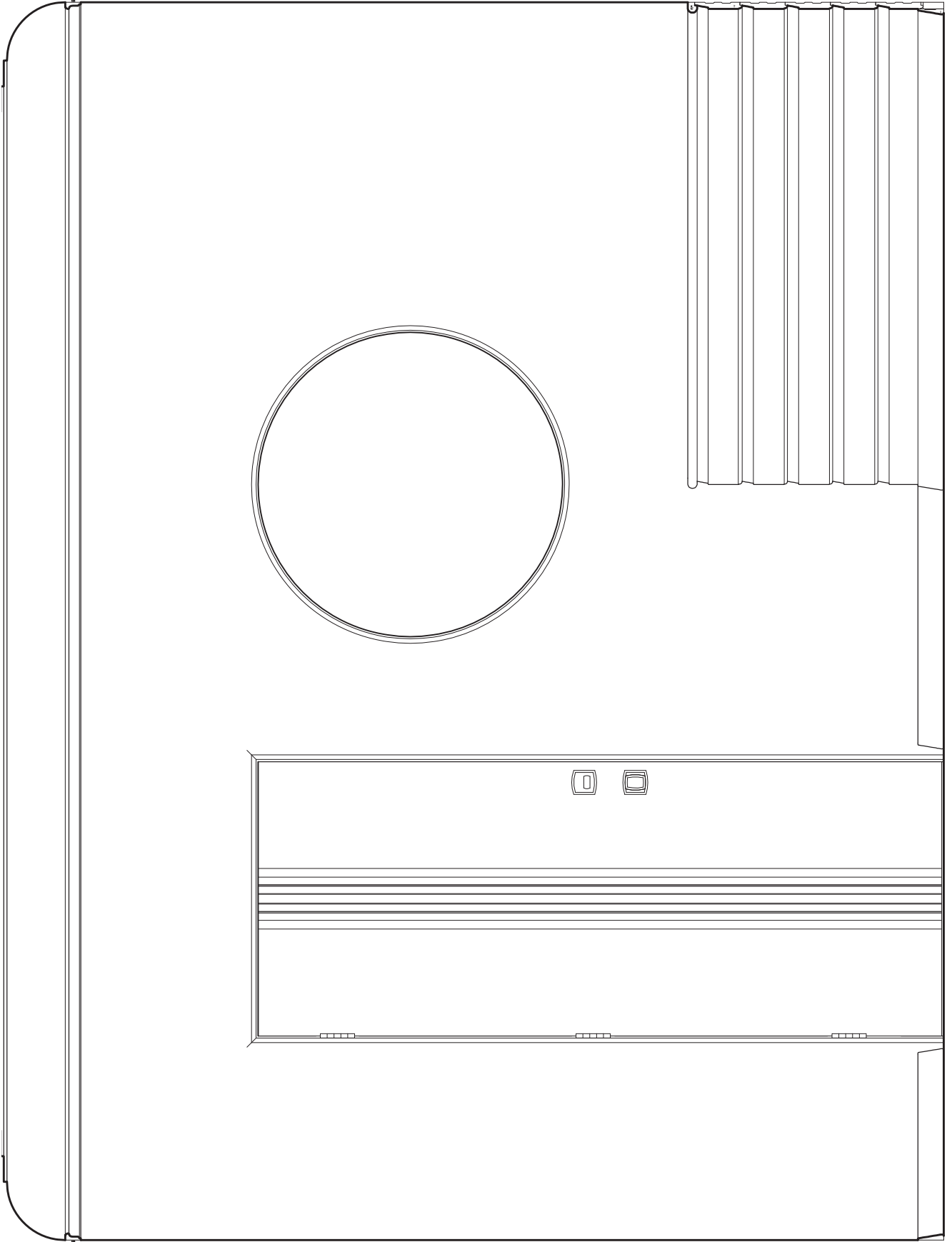

Drawing courtesy of The D. H. Ellison Co.

Scale: 3/4 inch = 1'

# Bauhaus Modern

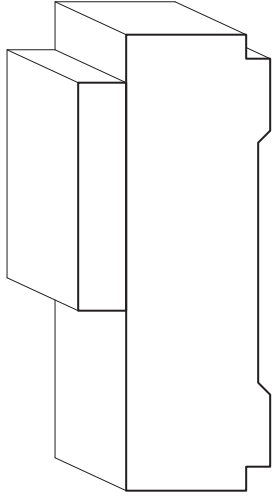

s4s w/ notches [1-1/4 x 4-3/4]

s4s [1/2 x 2-3/8]

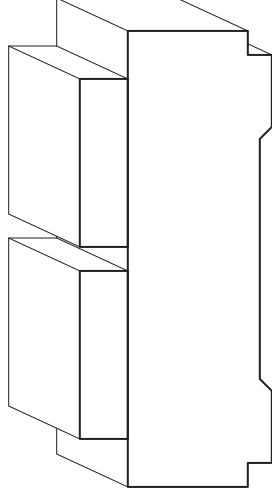

s4s w/ notches [1-1/4 x 4-3/4]

s4s [1/2 x 1-3/4]

s4s [1/2 x 1-3/4]

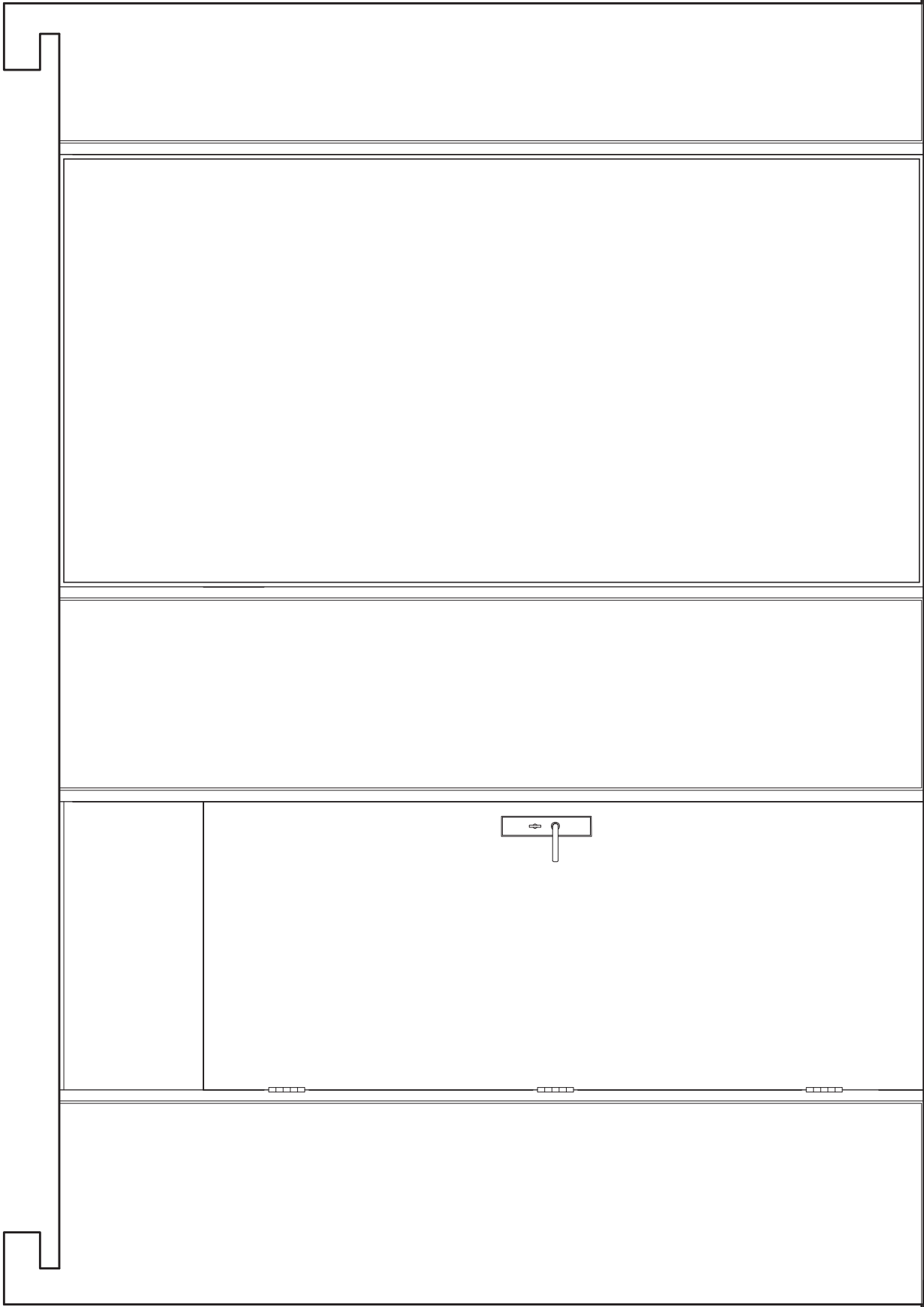

Drawing courtesy of The D. H. Ellison Co.

Scale: 3/4 inch = 1'

# Cabin

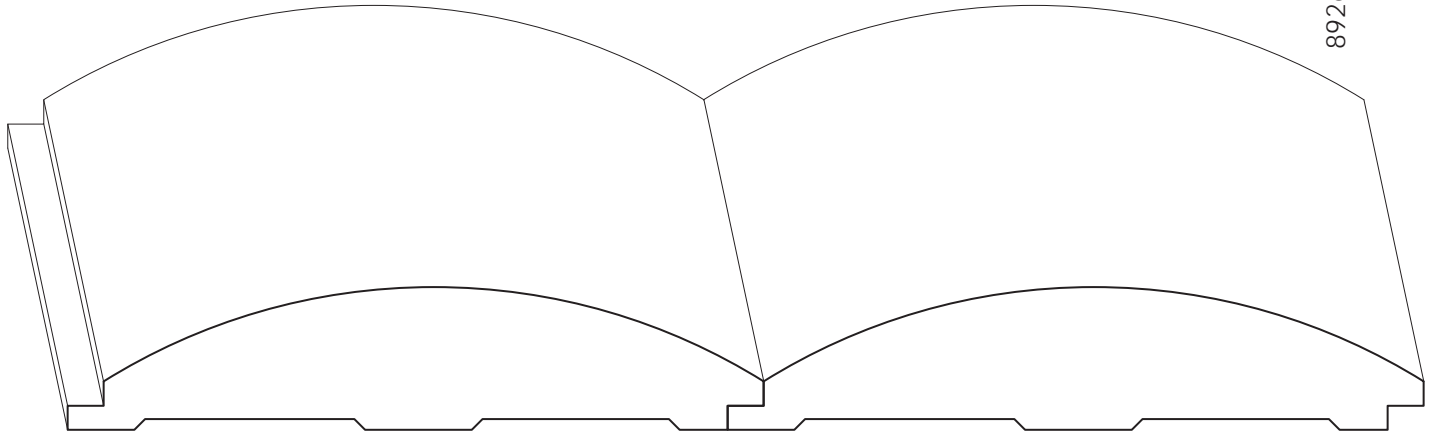

8926 [1-3/8 x 7-1/8]

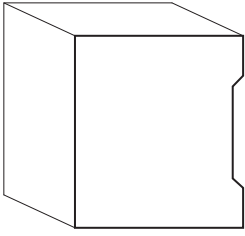

S4S [1-3/4 x 2]

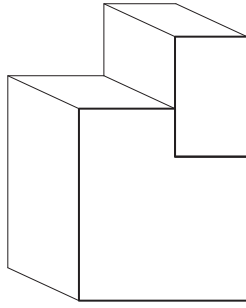

S4S [1-3/4 x 2]

S4S [3/4 x 1-1/4]

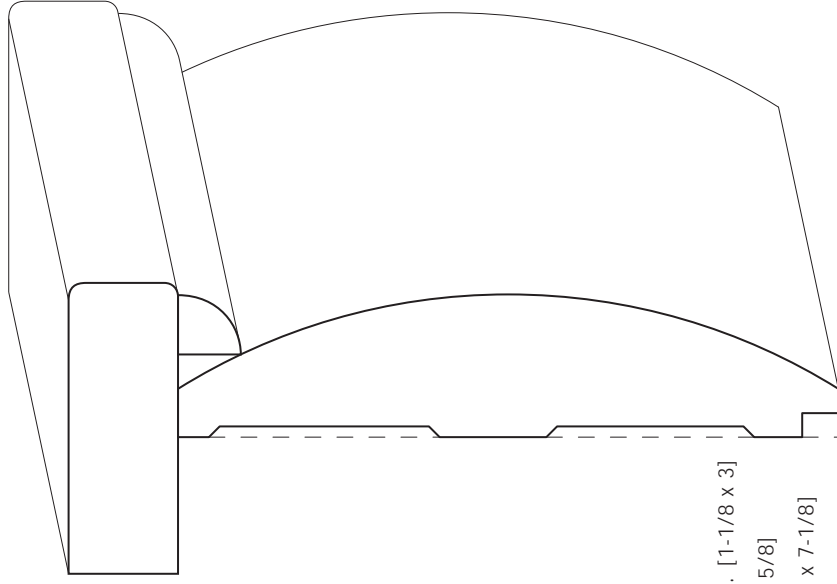

9002 Mod. [1-1/8 x 3]

5020 [5/8 x 5/8]

8926 [1-3/8 x 7-1/8]

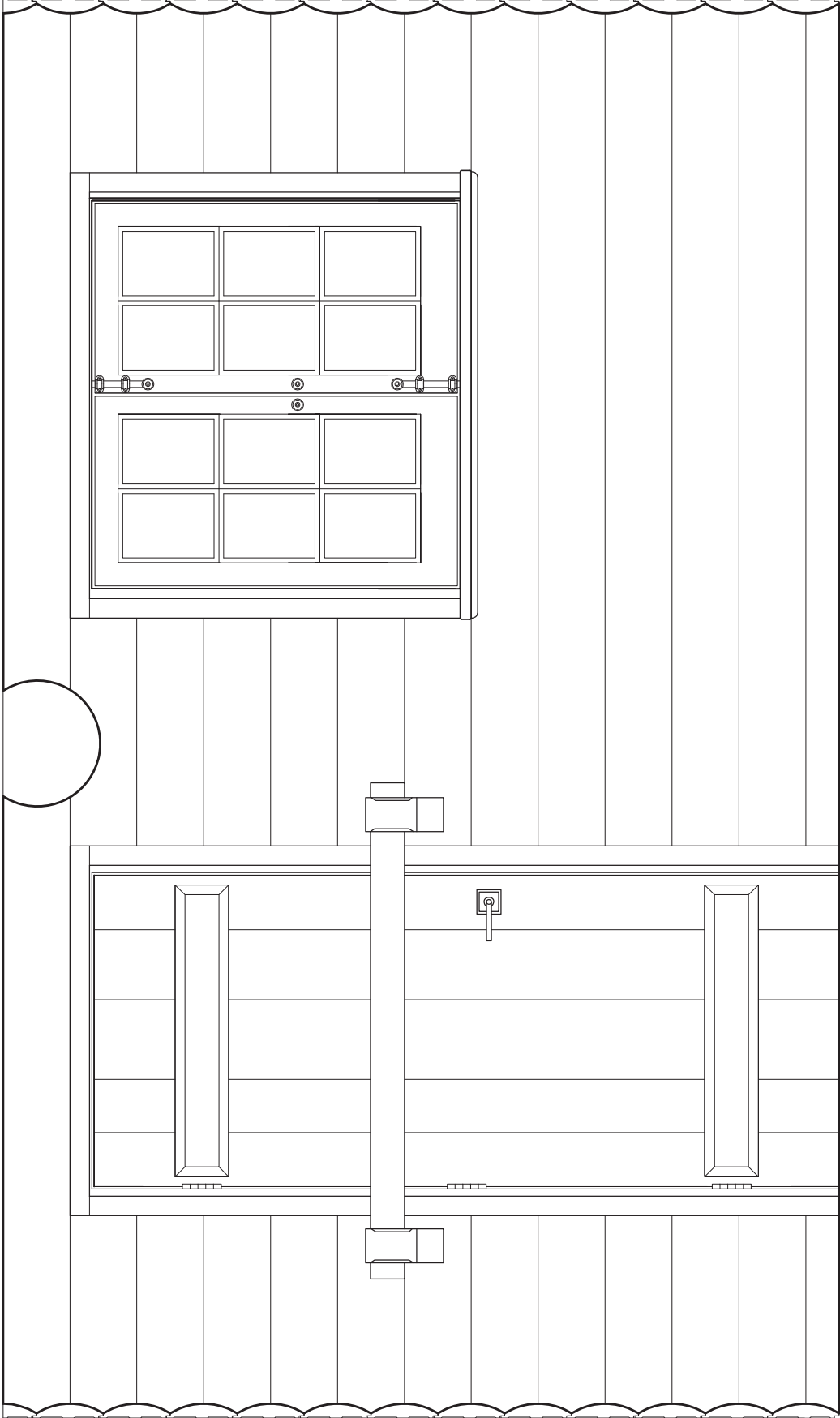

Drawing courtesy of The D. H. Ellison Co.

Scale: 3/4 inch = 1'

# Colonial

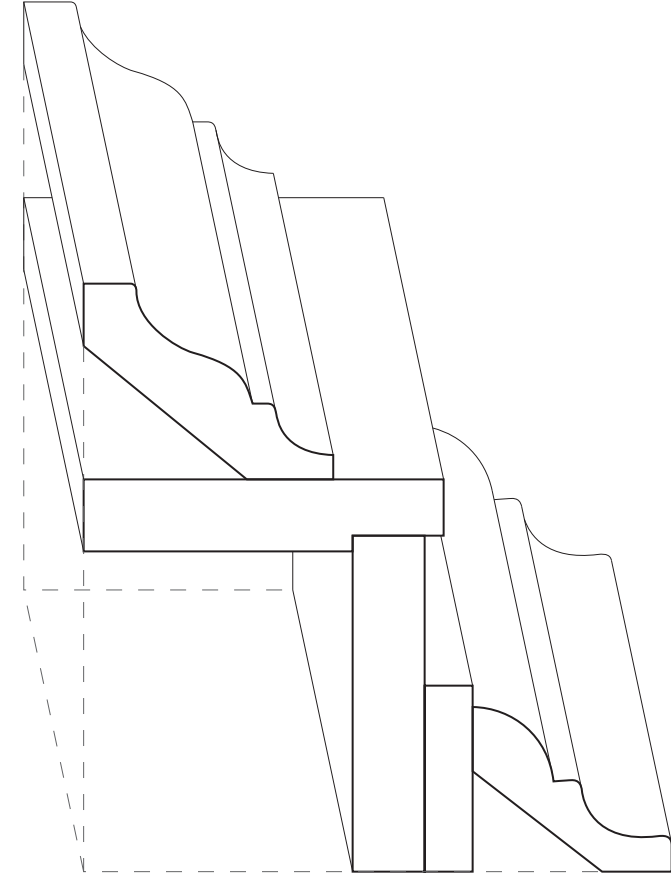

- 3082 [3/4 x 2-5/8]
- 3052 [3/4 x 3-1/4]
- S4S [3/4 x 3-1/2]
- S4S [3/4 x 3-3/4]
- S4S [1/2 x 2]

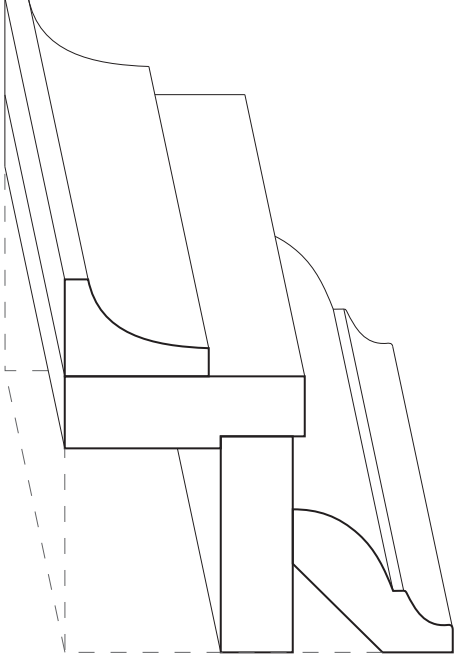

- 8074 [1 x 1-1/2]
- 3038 [3/4 x 3-3/8]
- S4S [3/4 x 2-1/4]
- S4S [3/4 x 2-1/2]



- 2024 [7/8 x 7-1/2]
- 5104 [5/16 x 1]

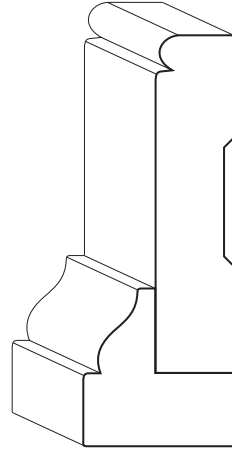

- 7034 [1-1/2 x 1-5/8]
- 1144 [13/16 x 3-1/2]

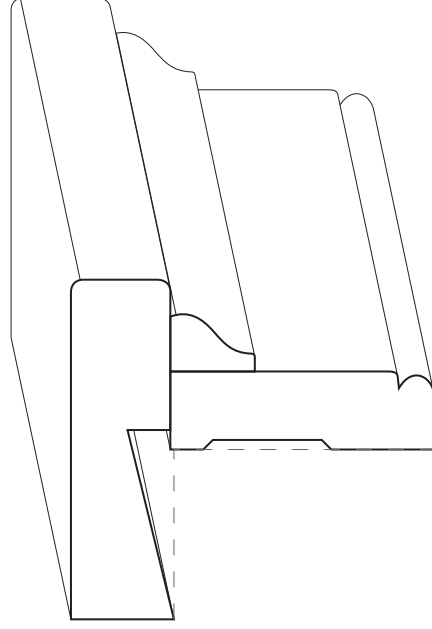

- 9002 [1-1/16 x 3-1/2]
- 7034 Mod [9/16 x 13/16]
- 1144 [13/16 x 3-1/2]



# Craftsman 1 (Arts & Crafts)

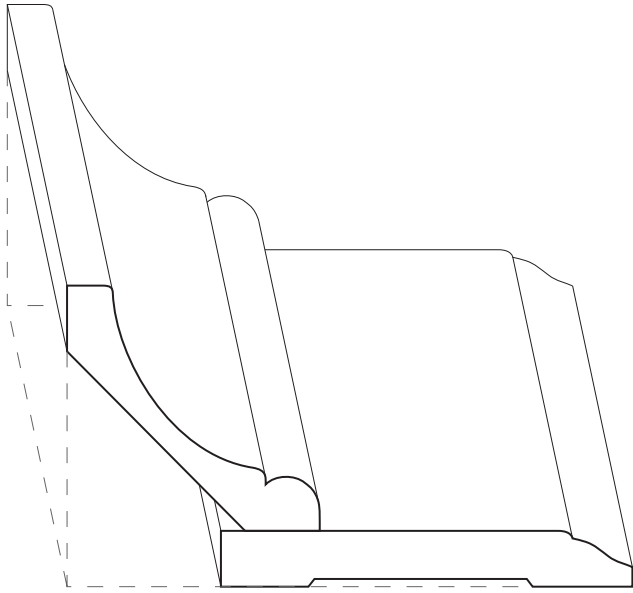

3054 [3/4 x 3-5/8]  
2012 [9/16 x 4-1/4]

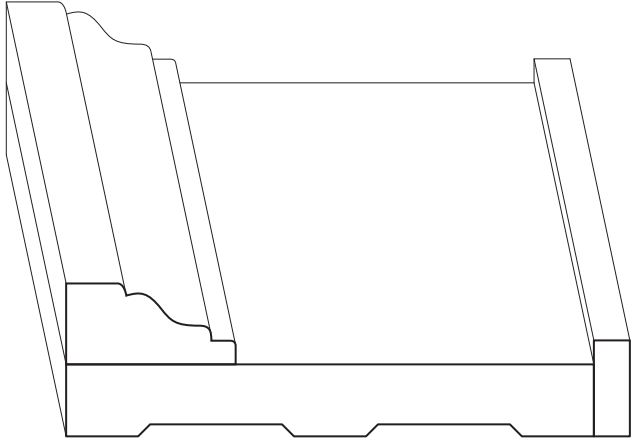

5233 [13/16 x 1-3/4]  
s4s w/ relief [3/4 x 5-1/2]  
s4s [3/8 x 1]

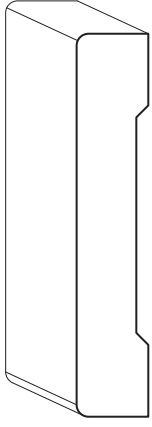

e2e [3/4 x 4-1/4]



Plinth [7/8 x 5-5/8]

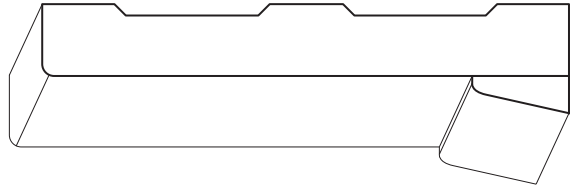

e1e [3/4 x 5-1/2]  
5104 [5/16 x 1]

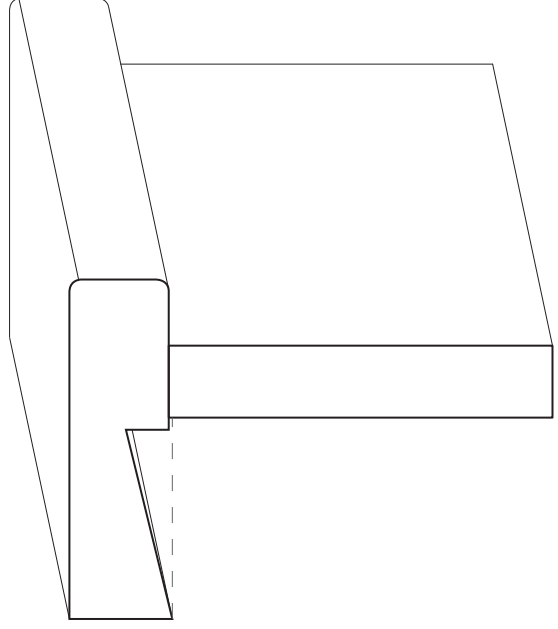

9002 [1-1/16 x 3-1/2]  
s4s [3/4 x 4]

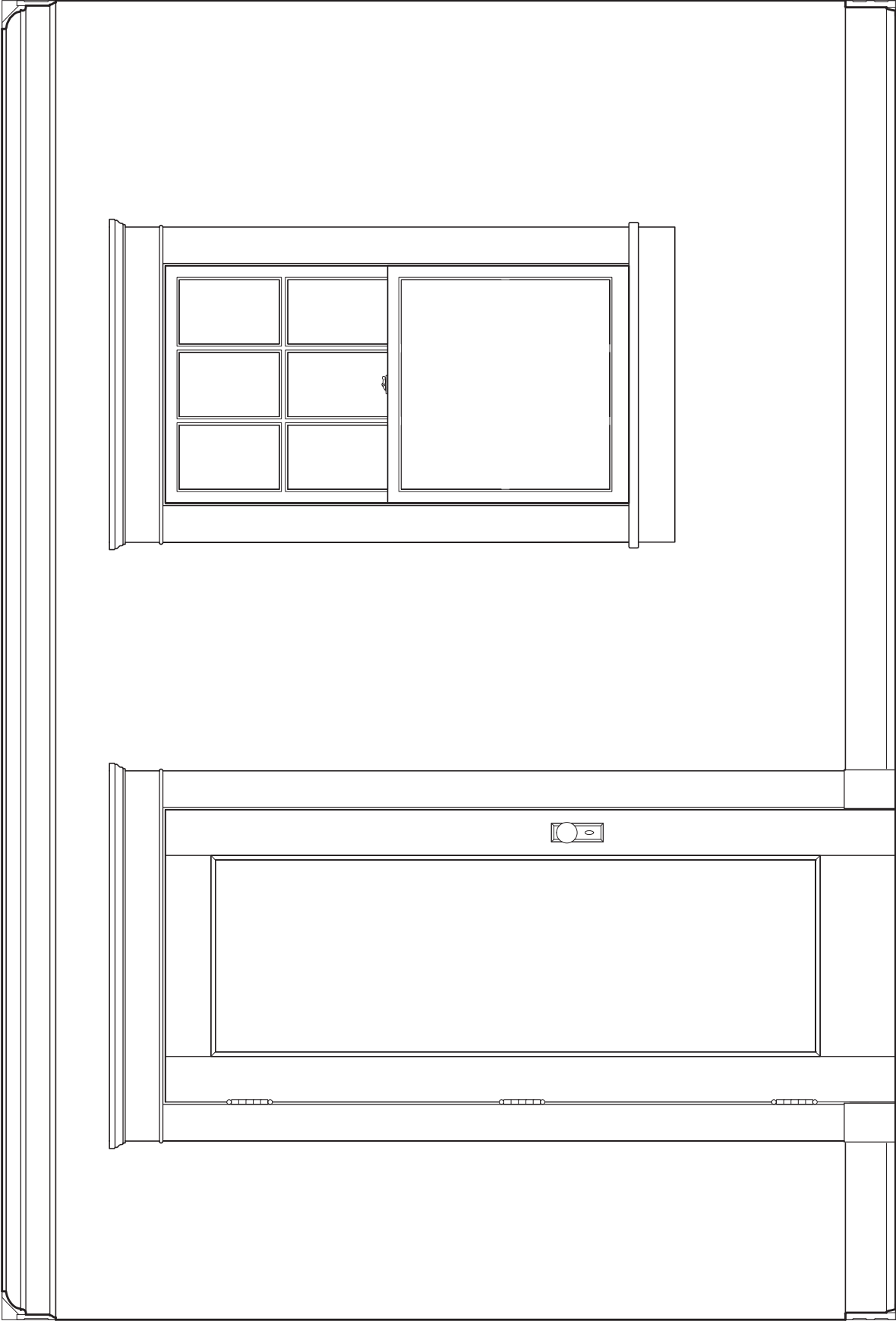

Drawing courtesy of The D. H. Ellison Co.

Scale: 3/4 inch = 1'

# Craftsman 2 (Arts & Crafts)

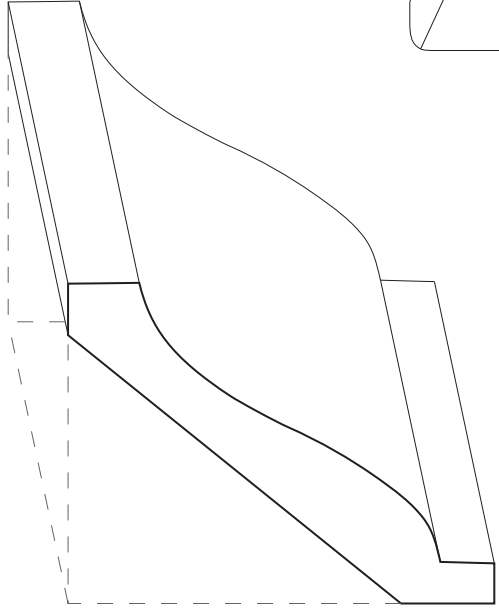

3041 [7/8 x 4-1/2]

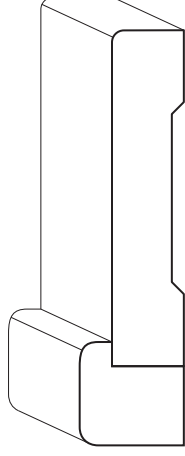

7026 [1-1/16 x 1-1/16]  
e1e [3/4 x 3-1/2]



e1e [3/4 x 5-1/2]  
5305 Mod [1/2 x 1-3/4]  
5104 [5/16 x 1]

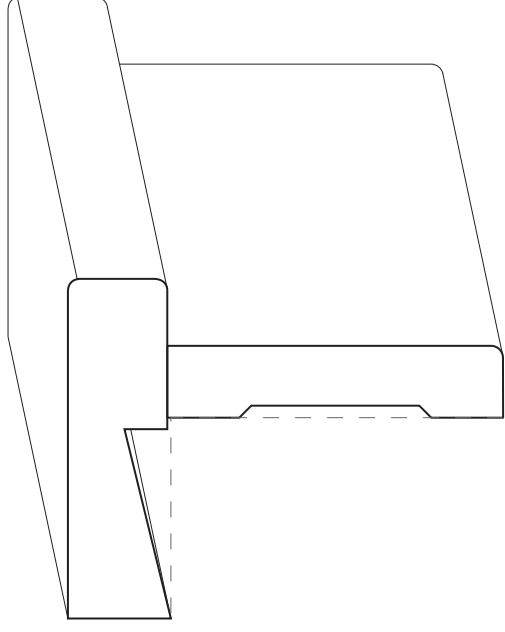

9002 [1-1/16 x 3-1/2]  
e1e [3/4 x 3-1/2]

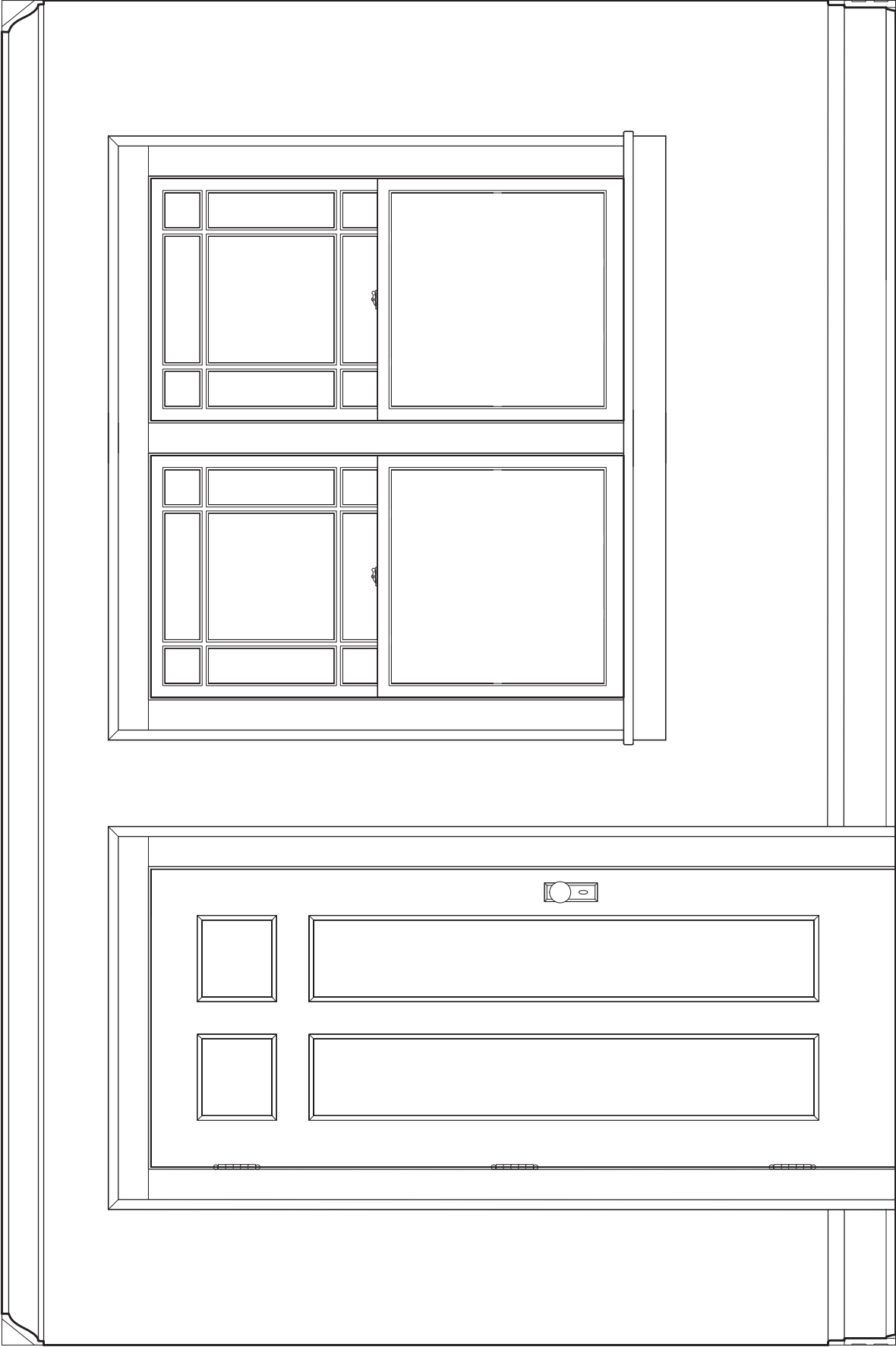

Drawing courtesy of The D. H. Ellison Co.

Scale: 3/4 inch = 1'

# Dutch

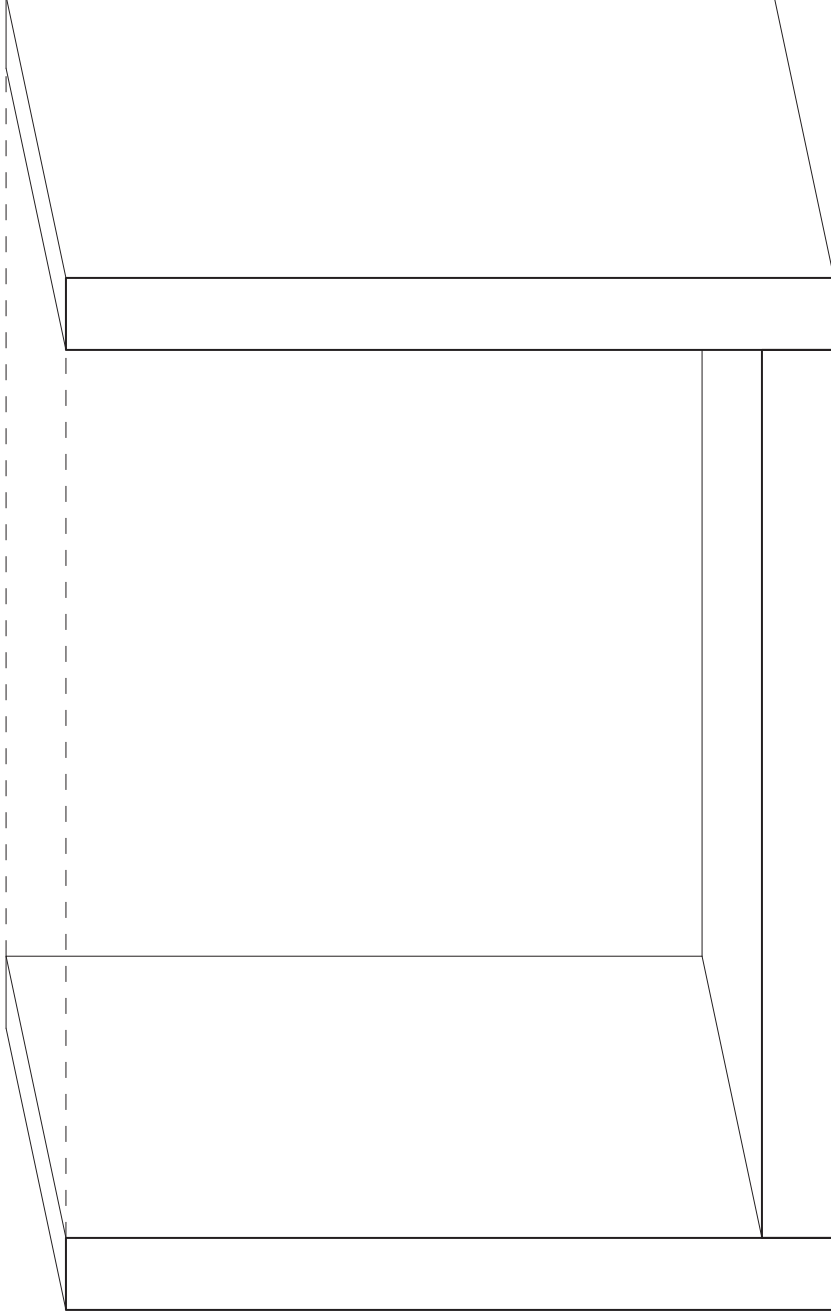

S4S [3/4 x 7-1/4]  
S4S [3/4 x 9-1/4]  
S4S [3/4 x 7-1/4]

2061 [3/4 x 7-1/2]  
5018 [1/2 x 11/16]

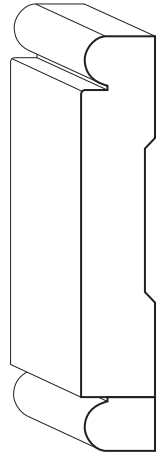

1126 [3/4 x 3-3/4]  
1126 Mod. [3/4 x 7/16]

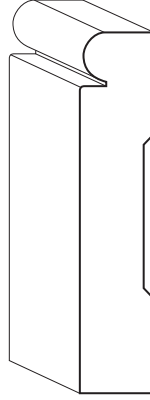

1126 [3/4 x 3-3/4]

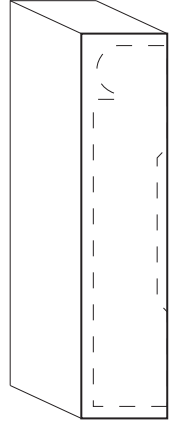

S4S Plinth [7/8 x 4]

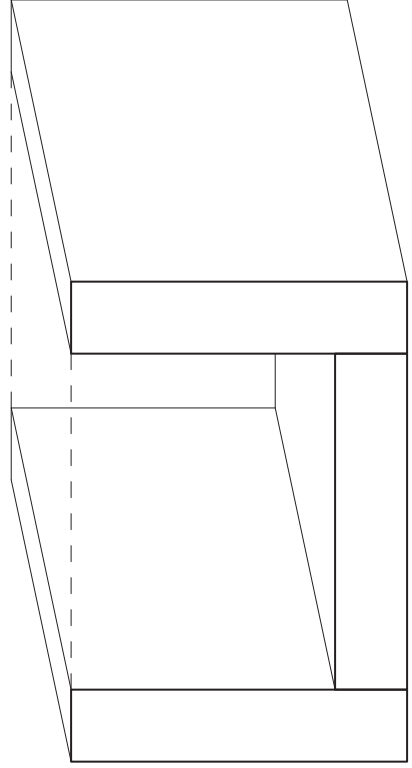

S4S [3/4 x 3-1/2]  
S4S [3/4 x 3-1/2]  
S4S [3/4 x 3-1/2]

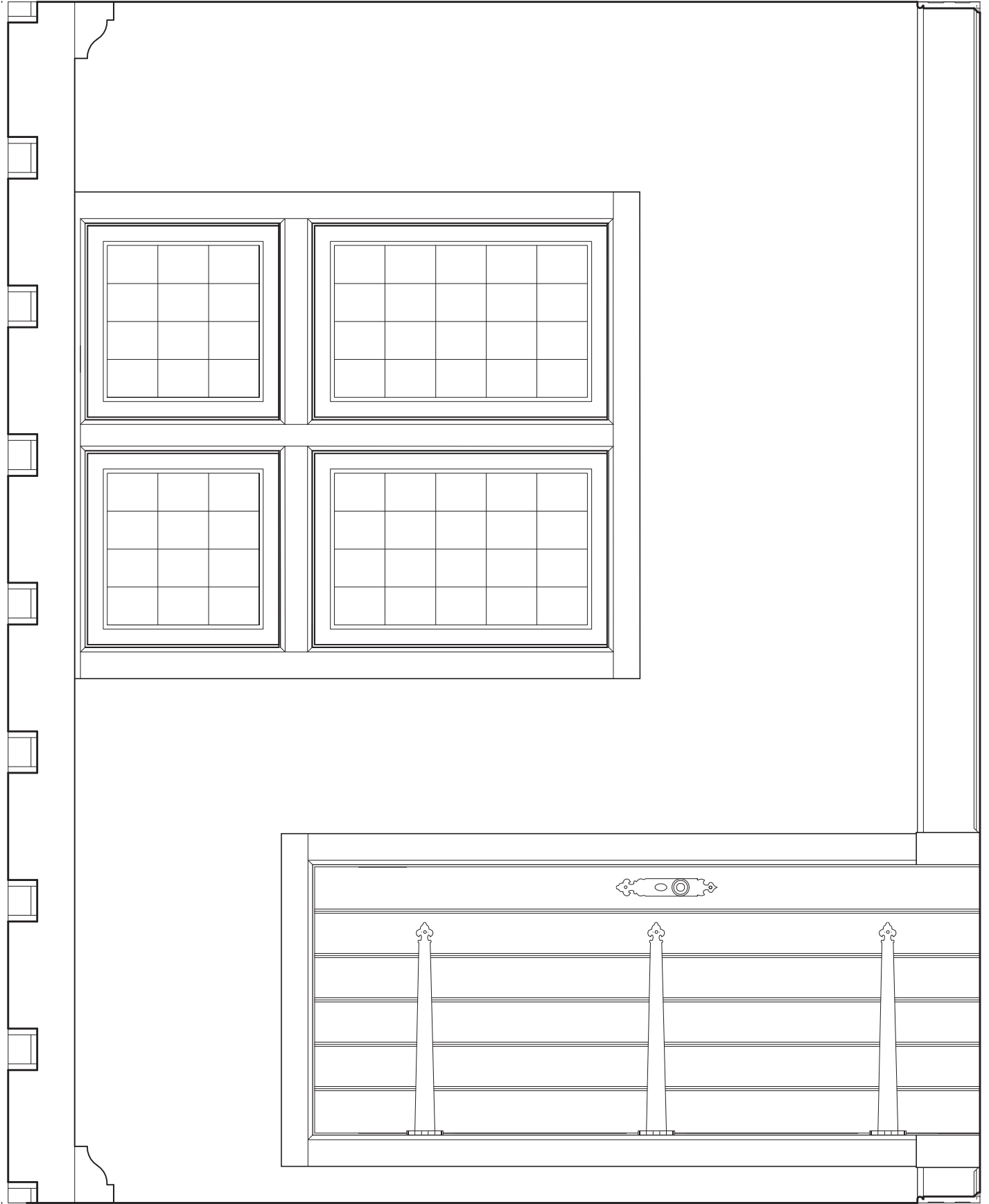

# Farmhouse

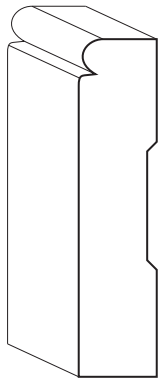

1144 [3/4 x 2-5/8]

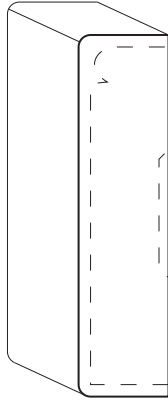

E2E [7/8 x 3-3/4]

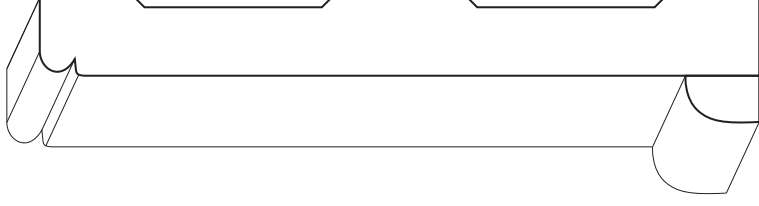
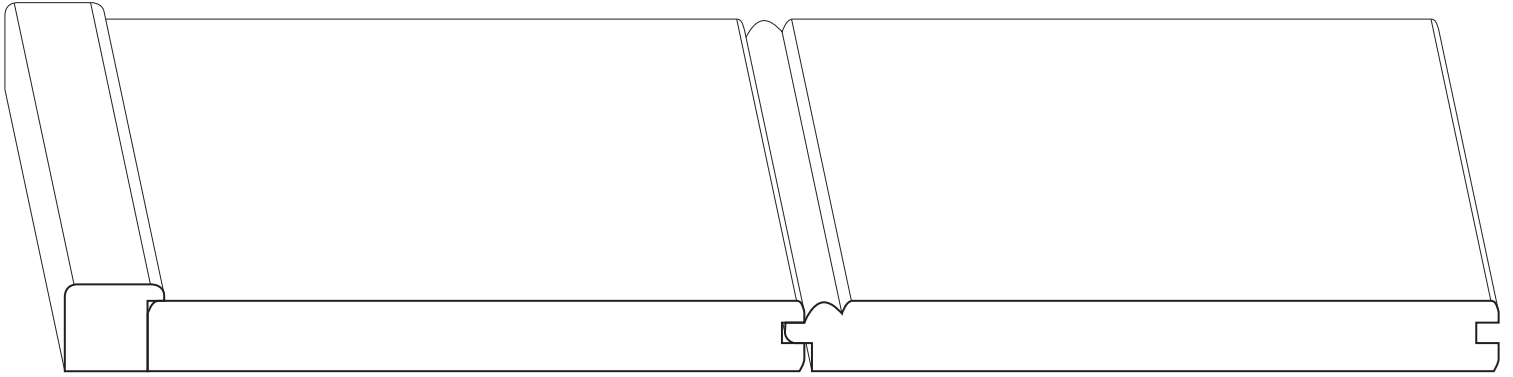

1144 Modified [3/4 x 7-1/2]

5101 [1/2 x 3/4]

9002 Modified [7/8 x 1]

8093 Modified [3/4 x 6-3/4]

8093 [3/4 x 6-3/4]

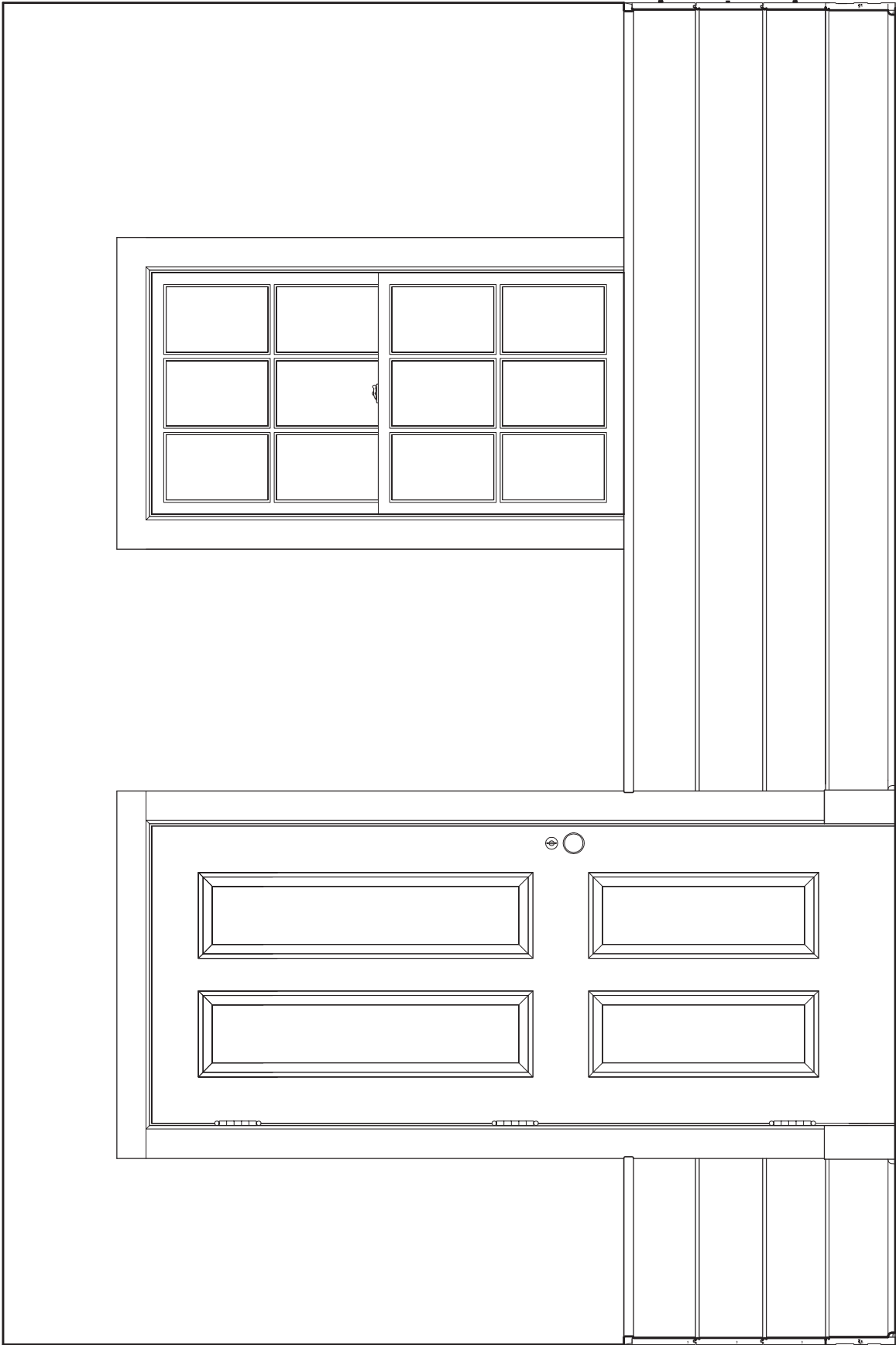

Drawing courtesy of The D. H. Ellison Co.

Scale: 3/4 inch = 1'

French City

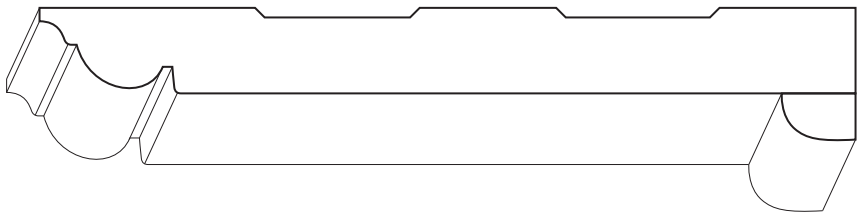

2081 [7/8 x 8-1/2]  
5101 [1/2 x 3/4]

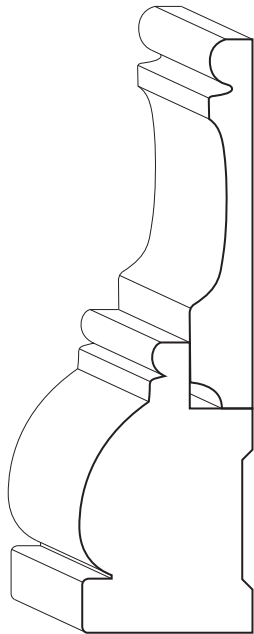
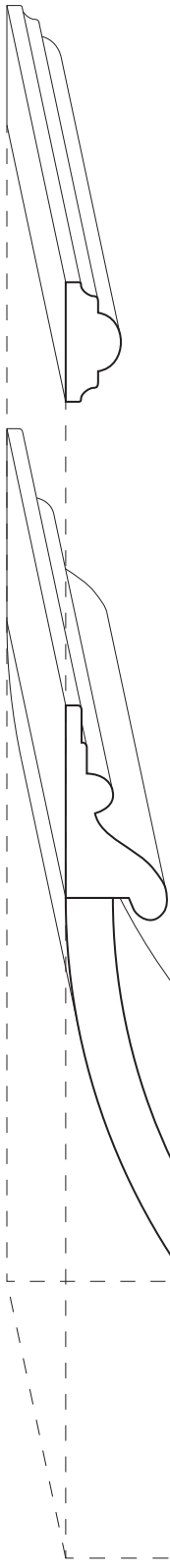

1157 [1-3/4 x 3]  
8014 [5/8 x 3-13/16]

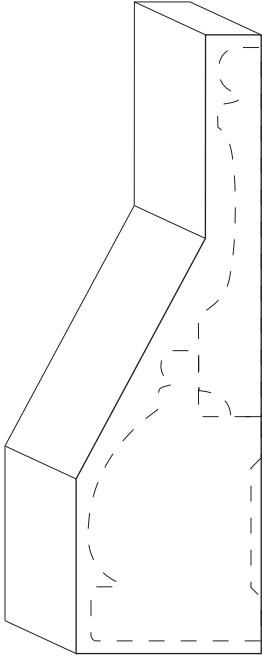

Custom Plinth [2 x 7]

5254 [9/16 x 1-1/4]  
7015 [1-1/16 x 1-1/4]  
1157 [1-1/8 x 3]  
8033 [13/16 x 1-3/4]

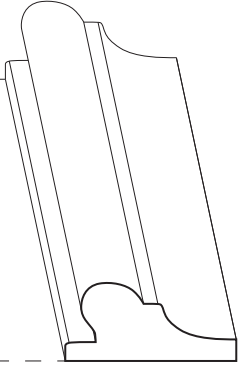

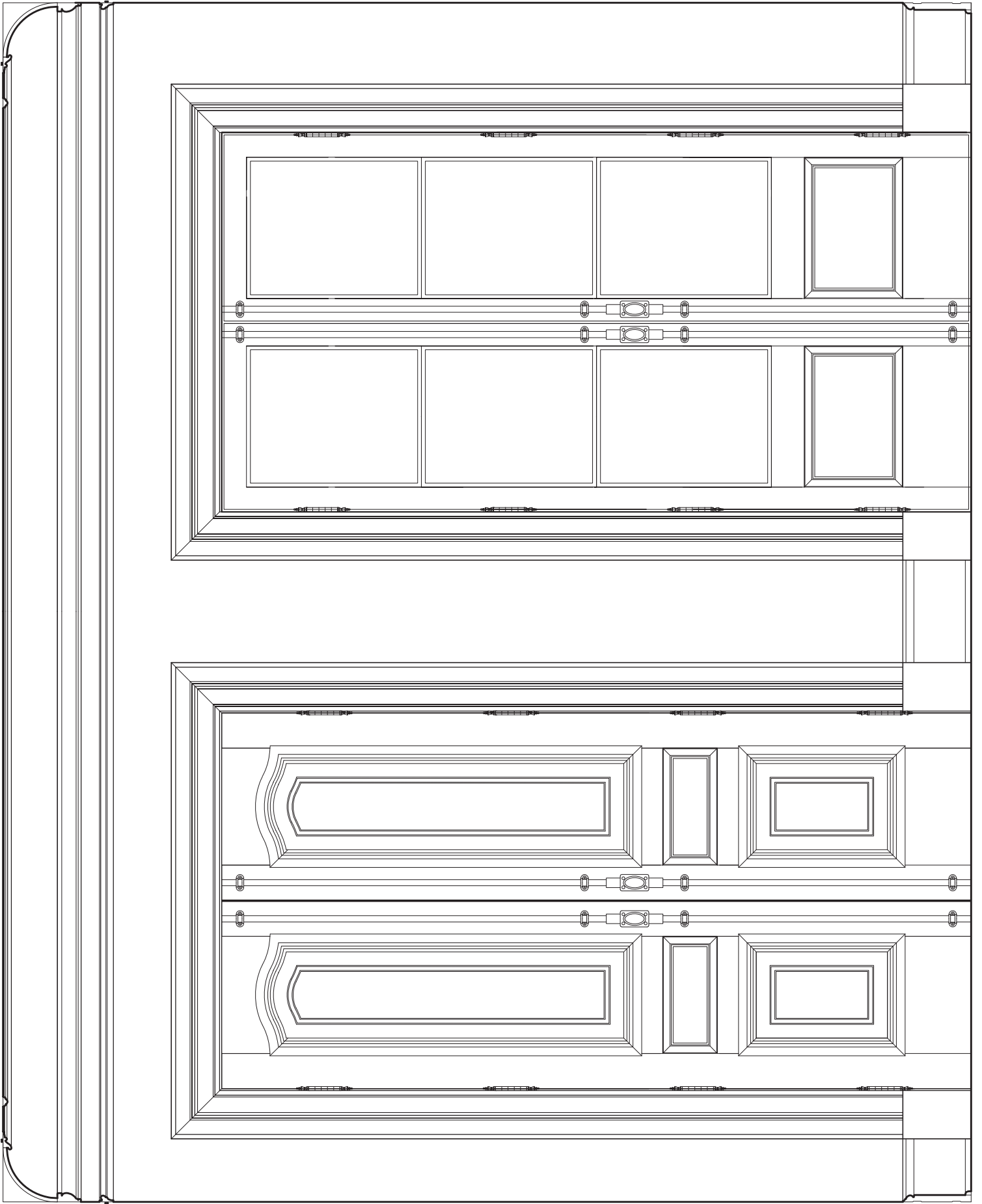

# French Country

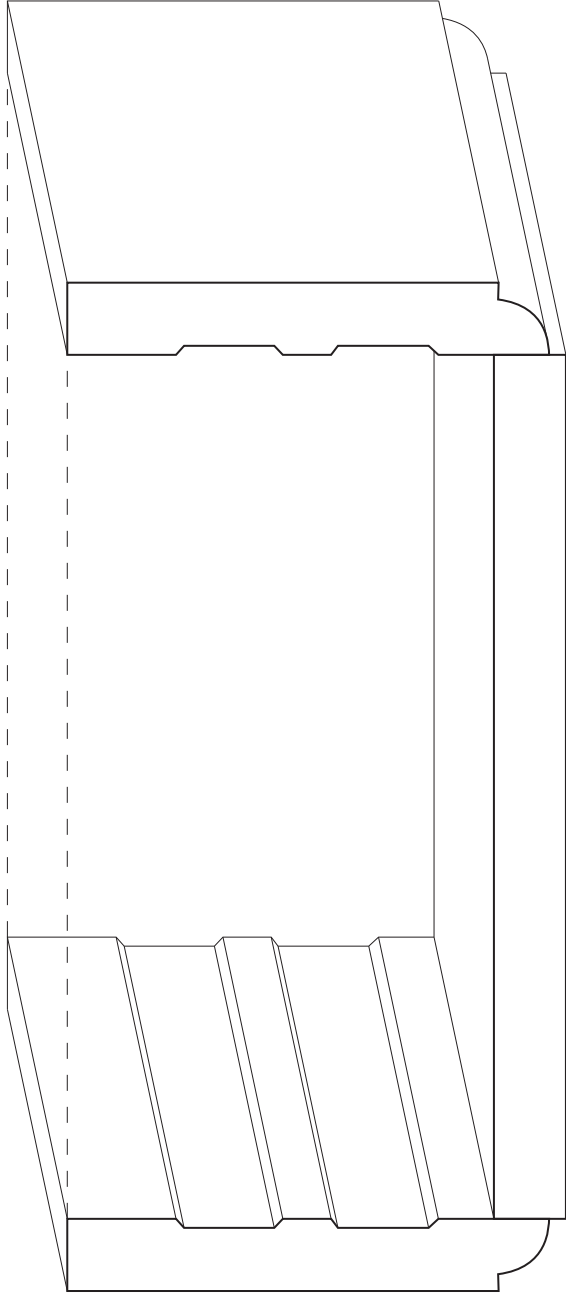

2033 [3/4 x 5]  
S4S [3/4 x 9]

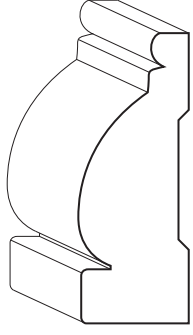

1157 [1-1/8 x 3]

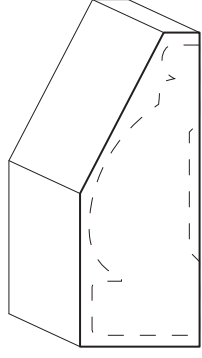

Custom Plinth [1-1/4 x 3-1/4]

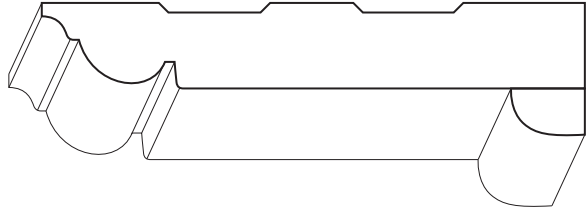

2081 [7/8 x 5-3/4]  
5101 [1/2 x 3/4]

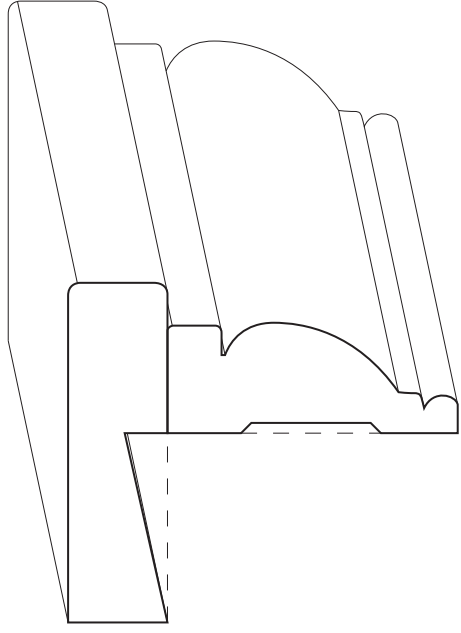

1157 [1-1/8 x 3]  
9002 [1-1/8 x 3-1/2]

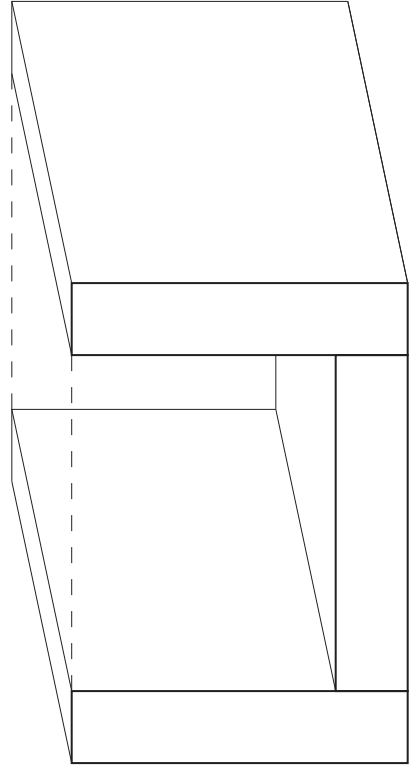

1 X 4 [3/4 x 3-1/2]

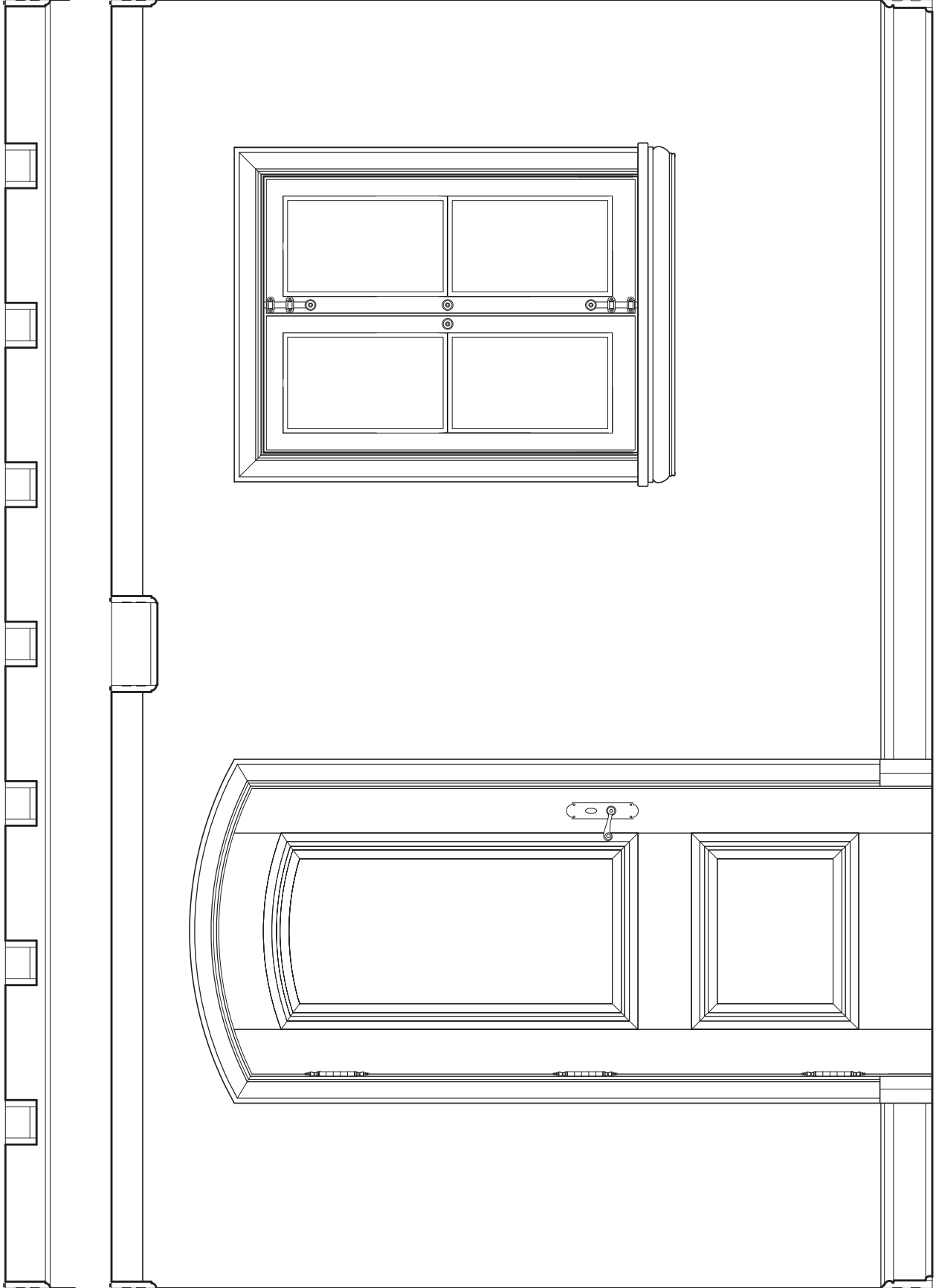

Drawing courtesy of The D. H. Ellison Co.

Scale: 3/4 inch = 1'

# Georgian 1

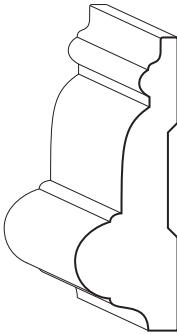

4018 [1-1/16 x 3]

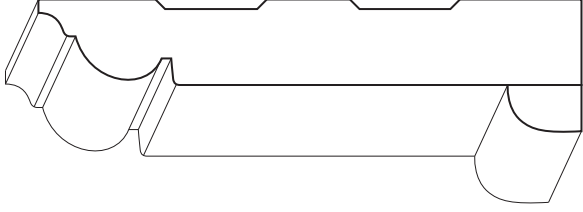
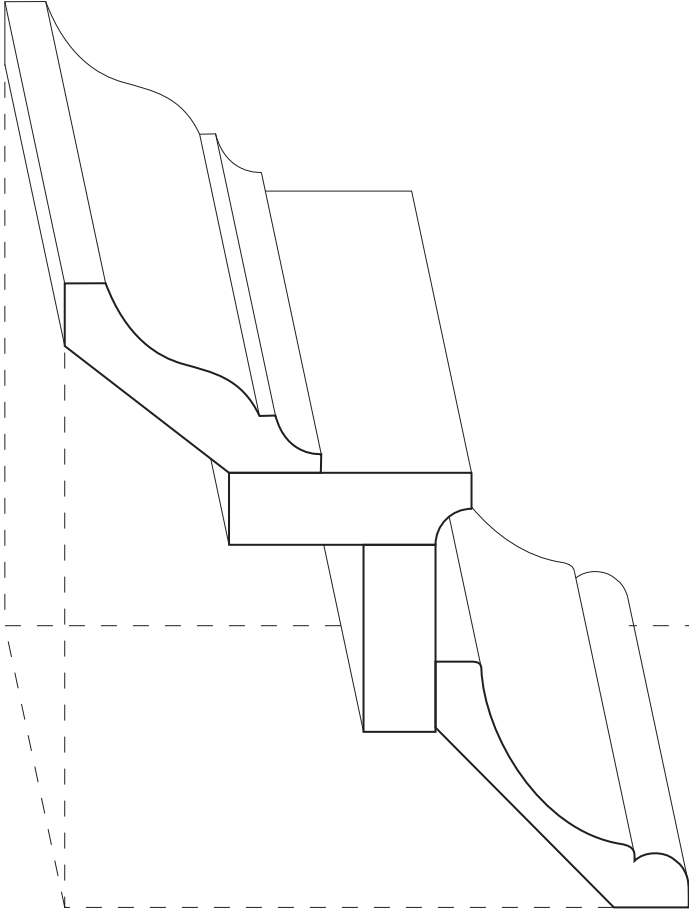

2081 [7/8 x 5-3/4]  
5101 [1/2 x 3/4]

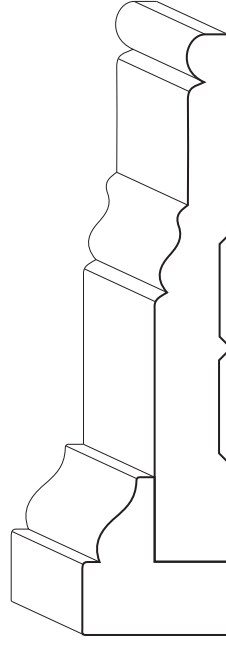

2067 [3/4 x 5-1/2]  
7034 [1-1/2 x 1-5/8]

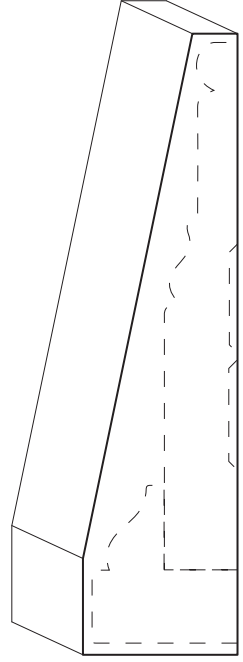

Custom Plinth [1-5/8 x 6-1/2]

- 3004 [3/4 x 3-1/4]
- S4S Cove [3/4 x 2-1/2]
- S4S [3/4 x 2]
- 3054 [3/4 x 3-5/8]
- 8033 [13/16 x 1-3/4]

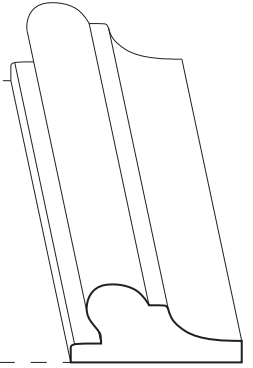

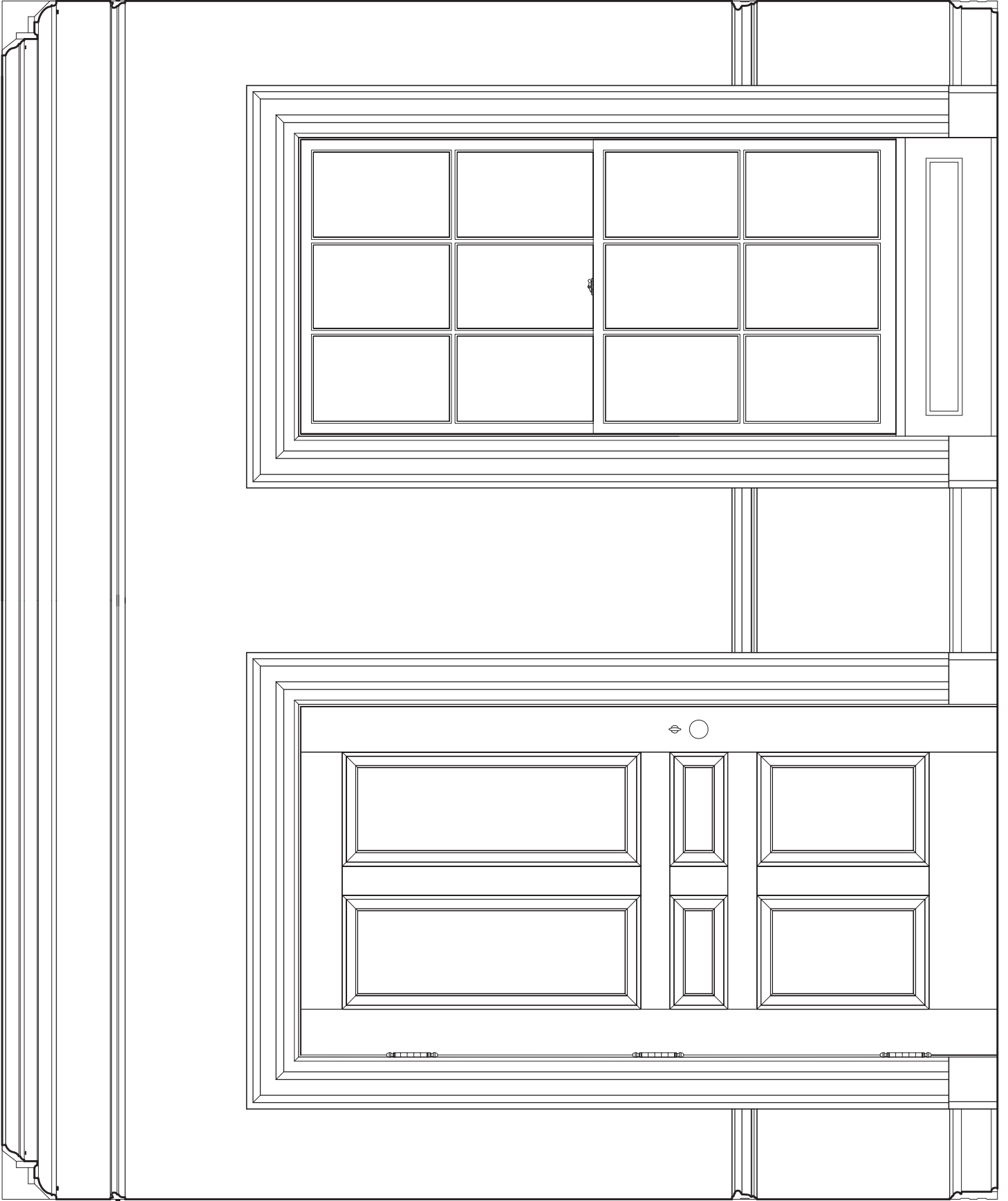

# Georgian 2

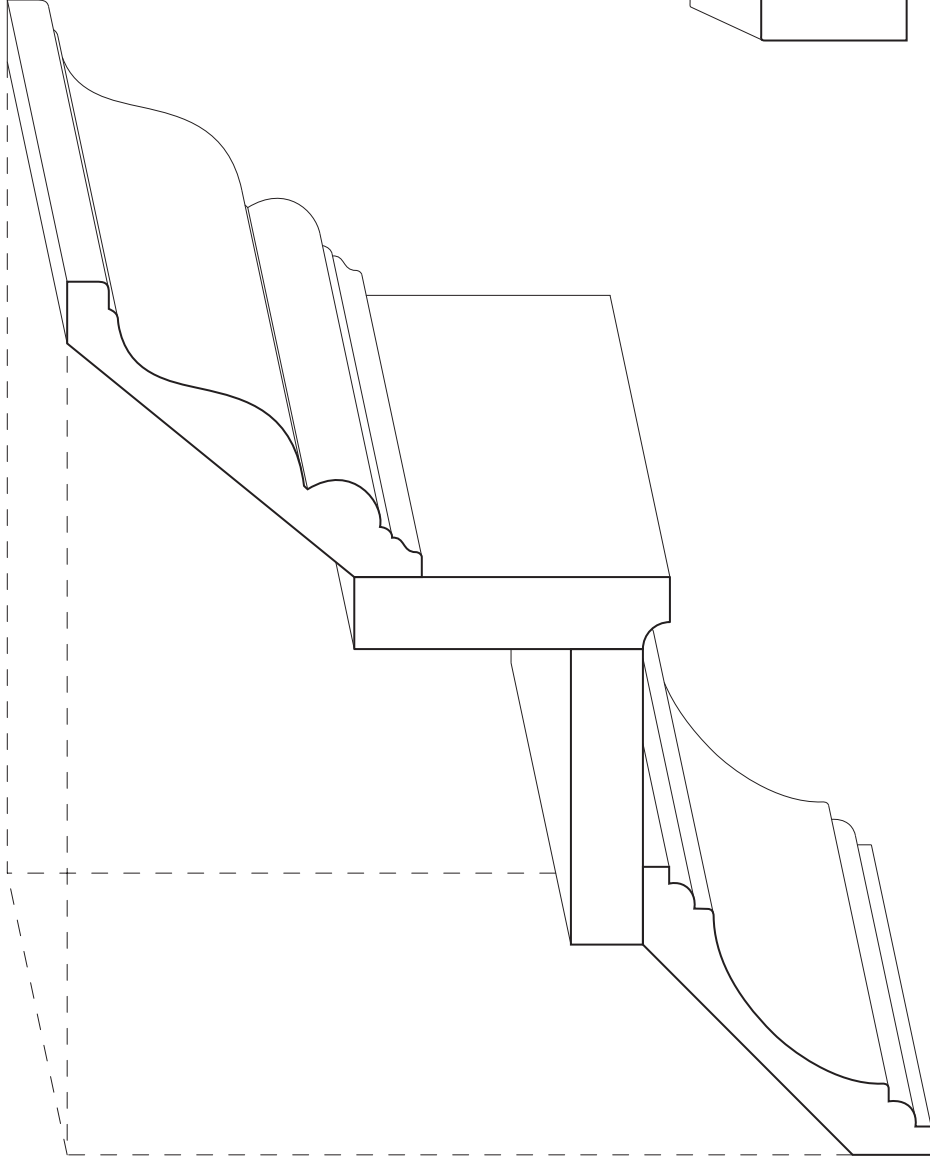

- 3078 [3/4 x 4-3/4]
- S4S Cove [3/4 x 3-1/4]
- S4S [3/4 x 3]
- 3034 [3/4 x 4-3/16]

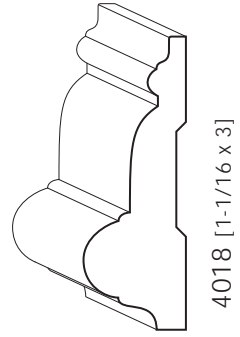

4018 [1-1/16 x 3]

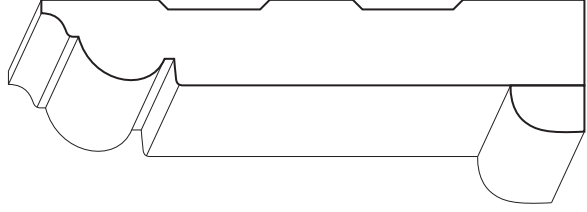

2081 [7/8 x 5-3/4]  
5101 [1/2 x 3/4]

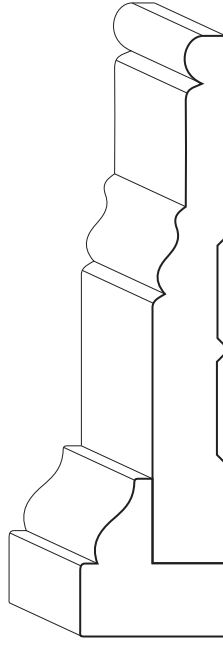

2067 [3/4 x 5-1/2]  
7034 [1-1/2 x 1-5/8]

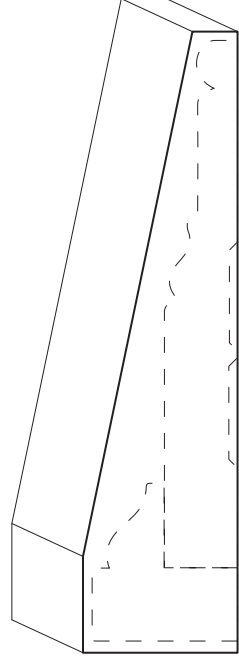

Custom Plinth [1-5/8 x 6-1/2]

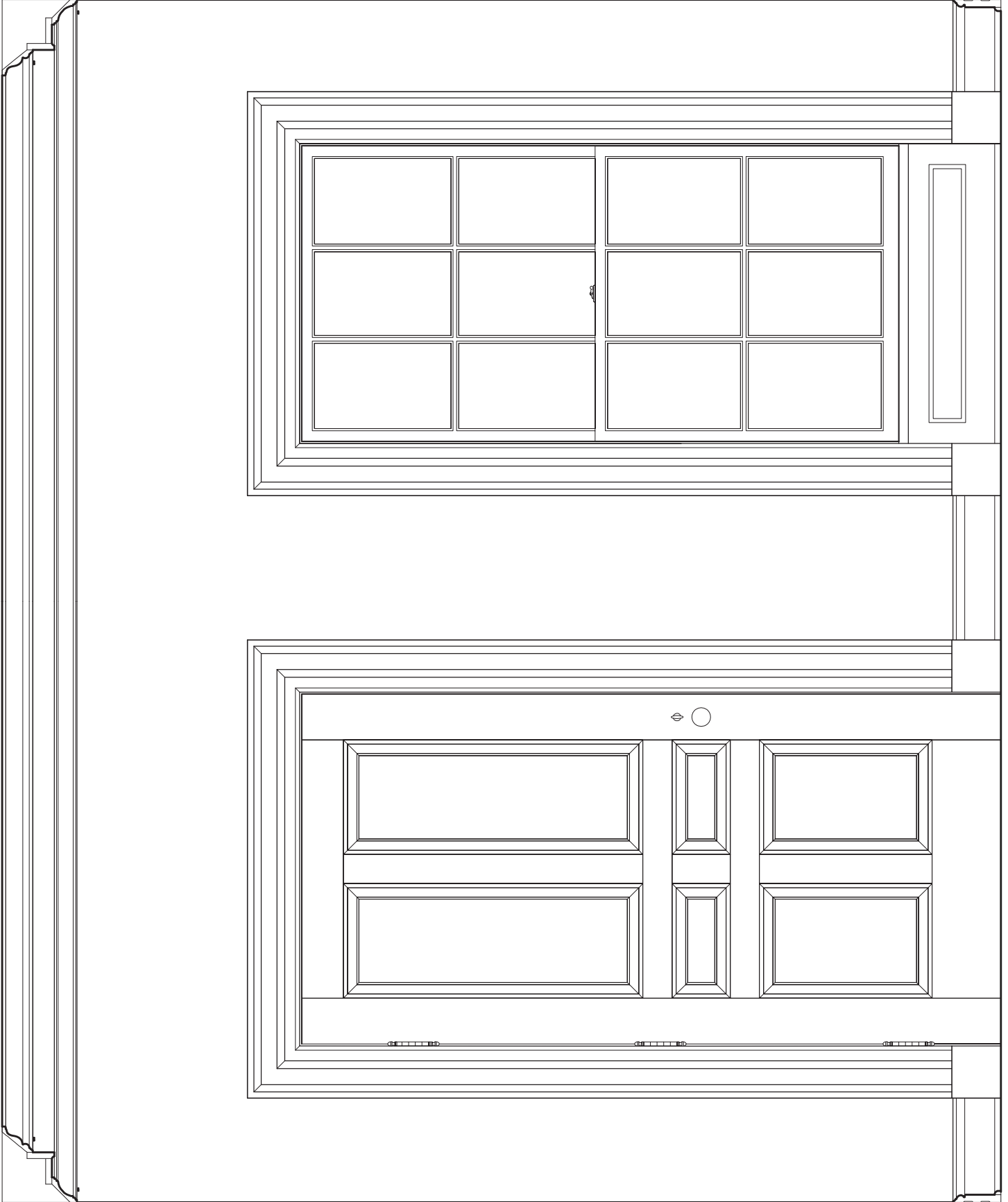

Drawing courtesy of The D. H. Ellison Co.

Scale: 3/4 inch = 1'

# Greek Revival 1

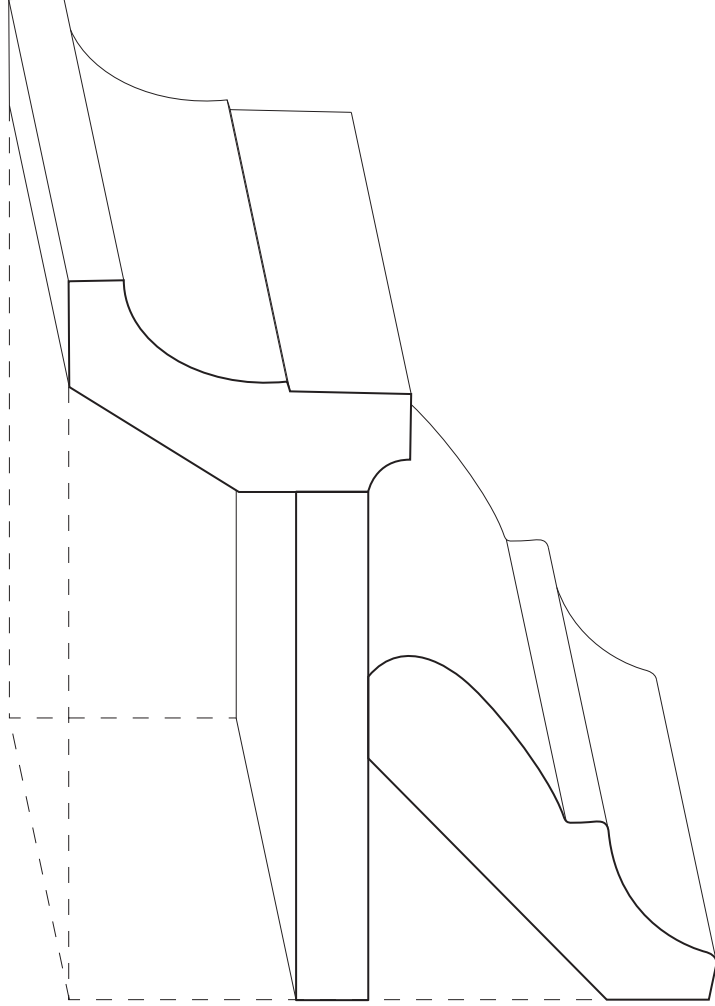

3020 [2-1/4 x 3-9/16]  
S4S [3/4 x 5-3/8]  
3075 [1-1/4 x 4-7/8]

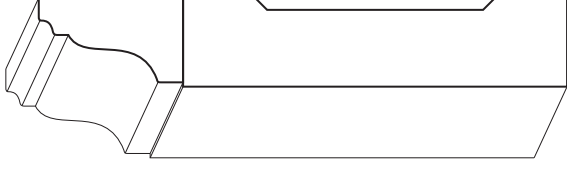

8073 [7/8 x 1-1/2]  
S4S [15/16 x 4]

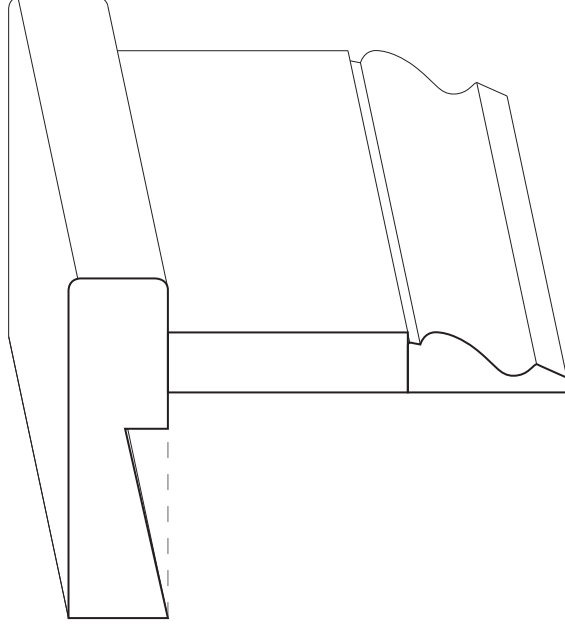

9002 [1-1/8 x 3-1/2]  
S4S [5/8 x 2-1/2]  
5216 [5/8 x 1-5/8]

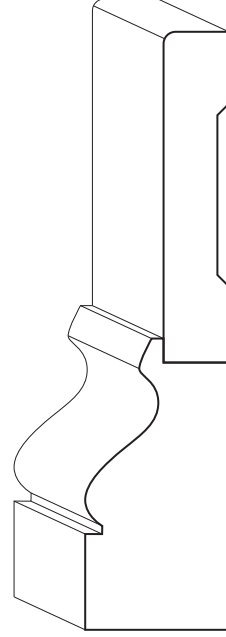

8004 Mod. [1-1/2 x 3]  
E1E [11/16 x 3-1/2]

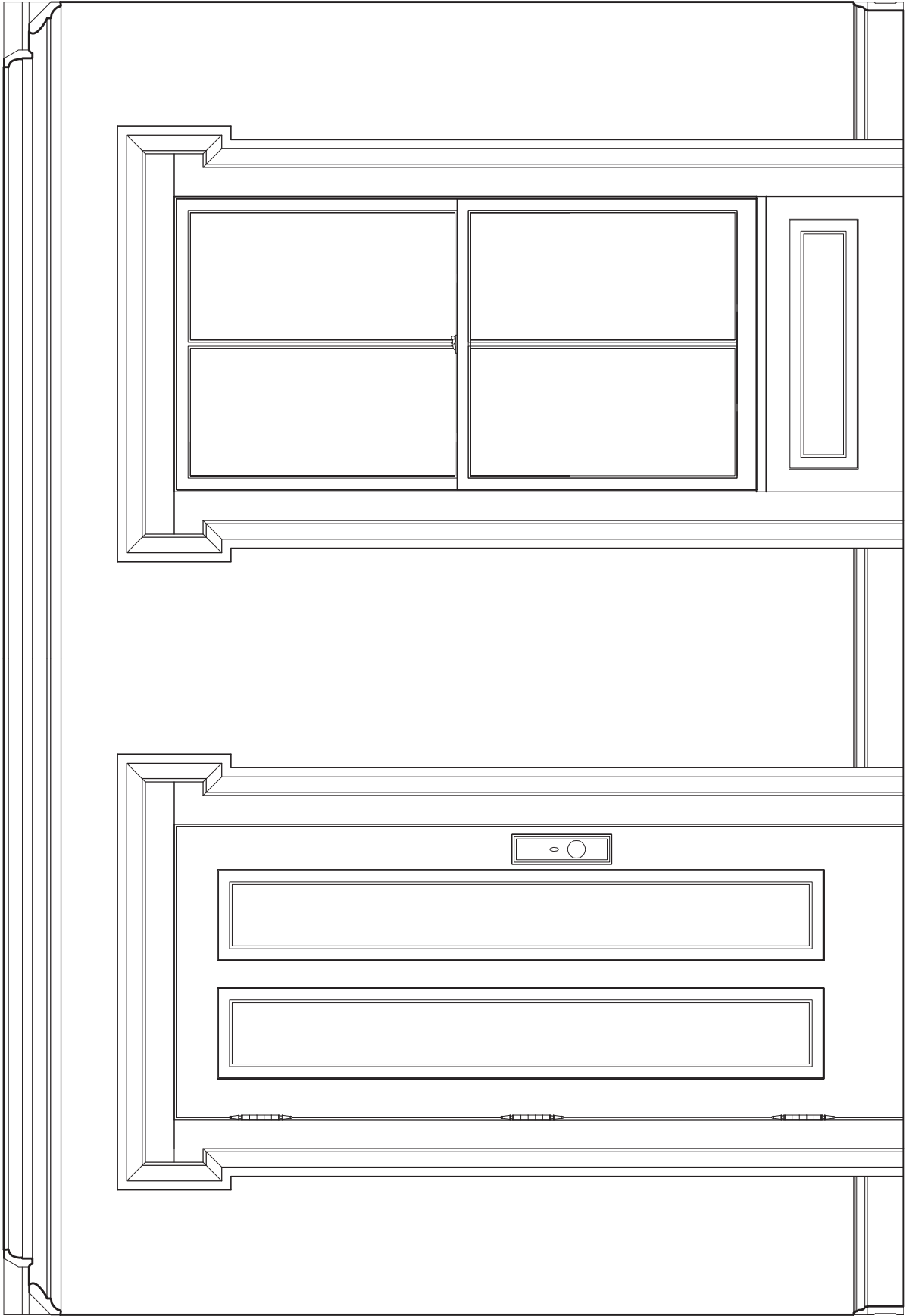

Drawing courtesy of The D. H. Ellison Co.

Scale: 3/4 inch = 1'

# Greek Revival 2

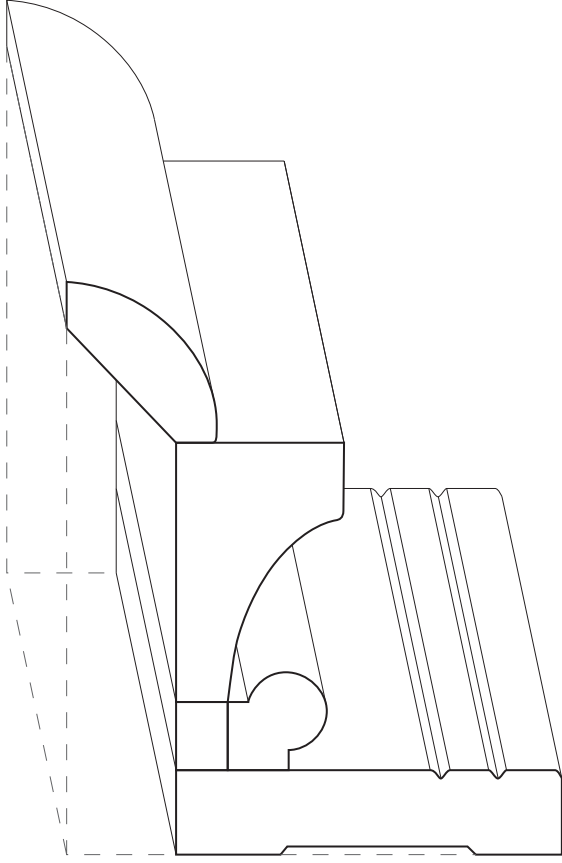

3048 [3/4 x 2-1/4]

8029 [1-3/4 x 2-3/4]

5031 [1 x 1]

2032 [7/8 x 4]

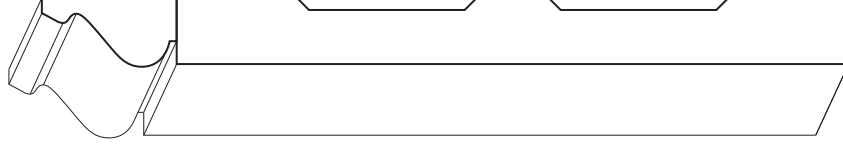

15401 [11/16 x 1-3/8]

S4S [11/16 x 7]

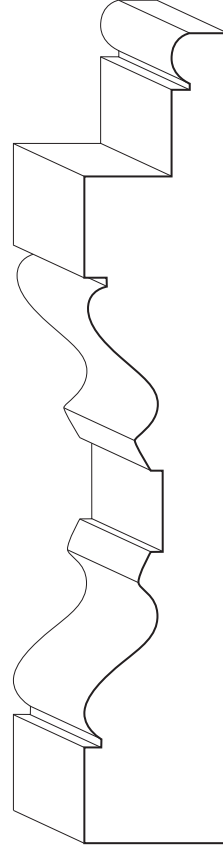

8004 [1-1/2 x 8-1/2]

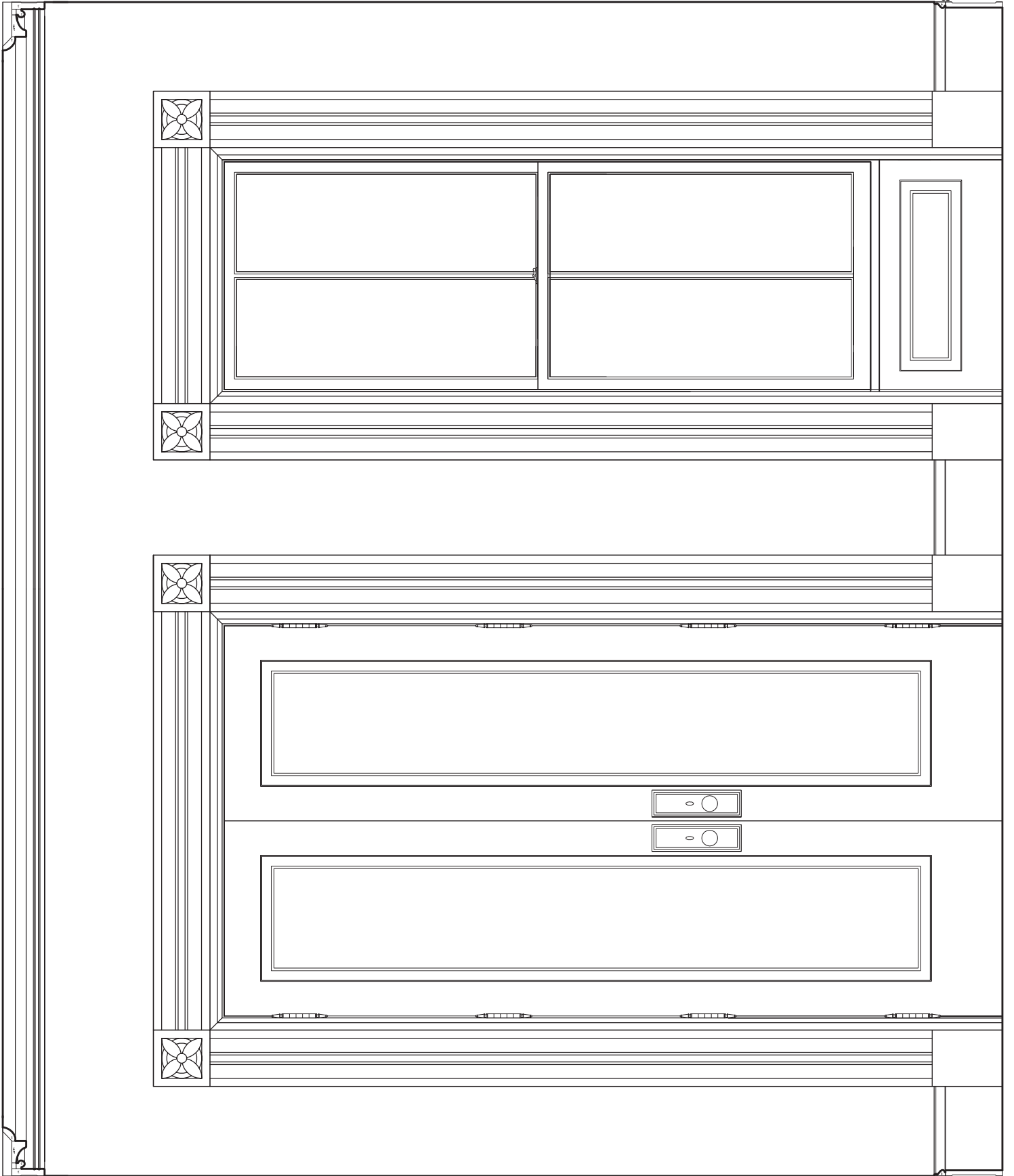

# Italianate

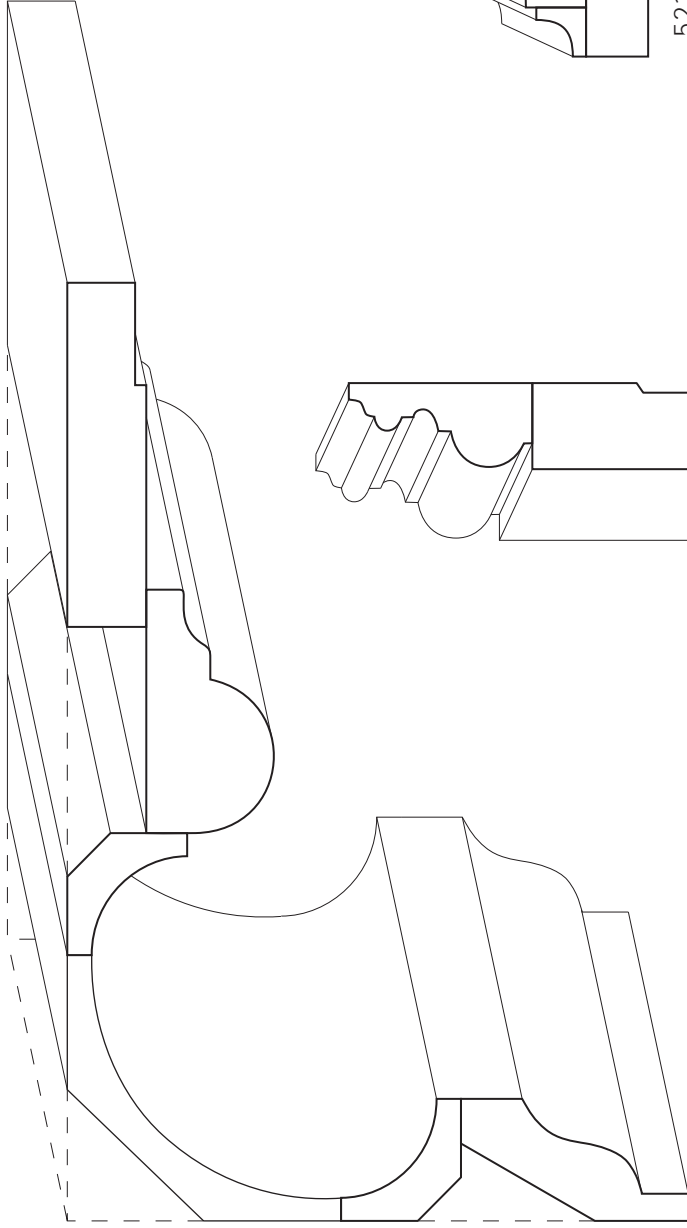

- 1036 [13/16 x 3-1/2]
- 8086 [1-5/16 x 2-1/2]
- 3102 [3/4 x 1-3/4]
- 3039 Mod. [1-1/8 x 4-1/8]
- 3102 [3/4 x 1-3/4]
- 3030 [3/4 x 2-3/4]



- 5215 [7/8 x 1-7/8]
- S4S [7/8 x 7]

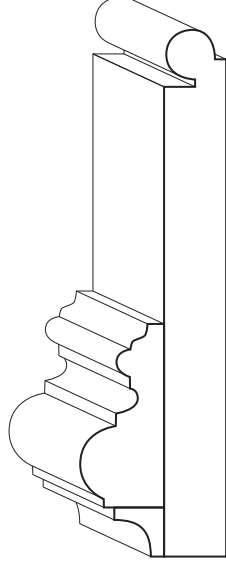

- 5215 [7/8 x 1-7/8]
- 3103 [1/2 x 1/2]
- 8051 [5/8 x 5-1/2]

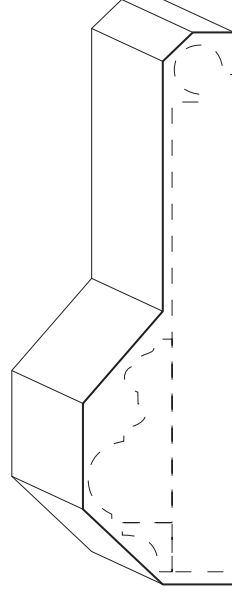

- Custom Plinth [1-5/8 x 5-3/4]

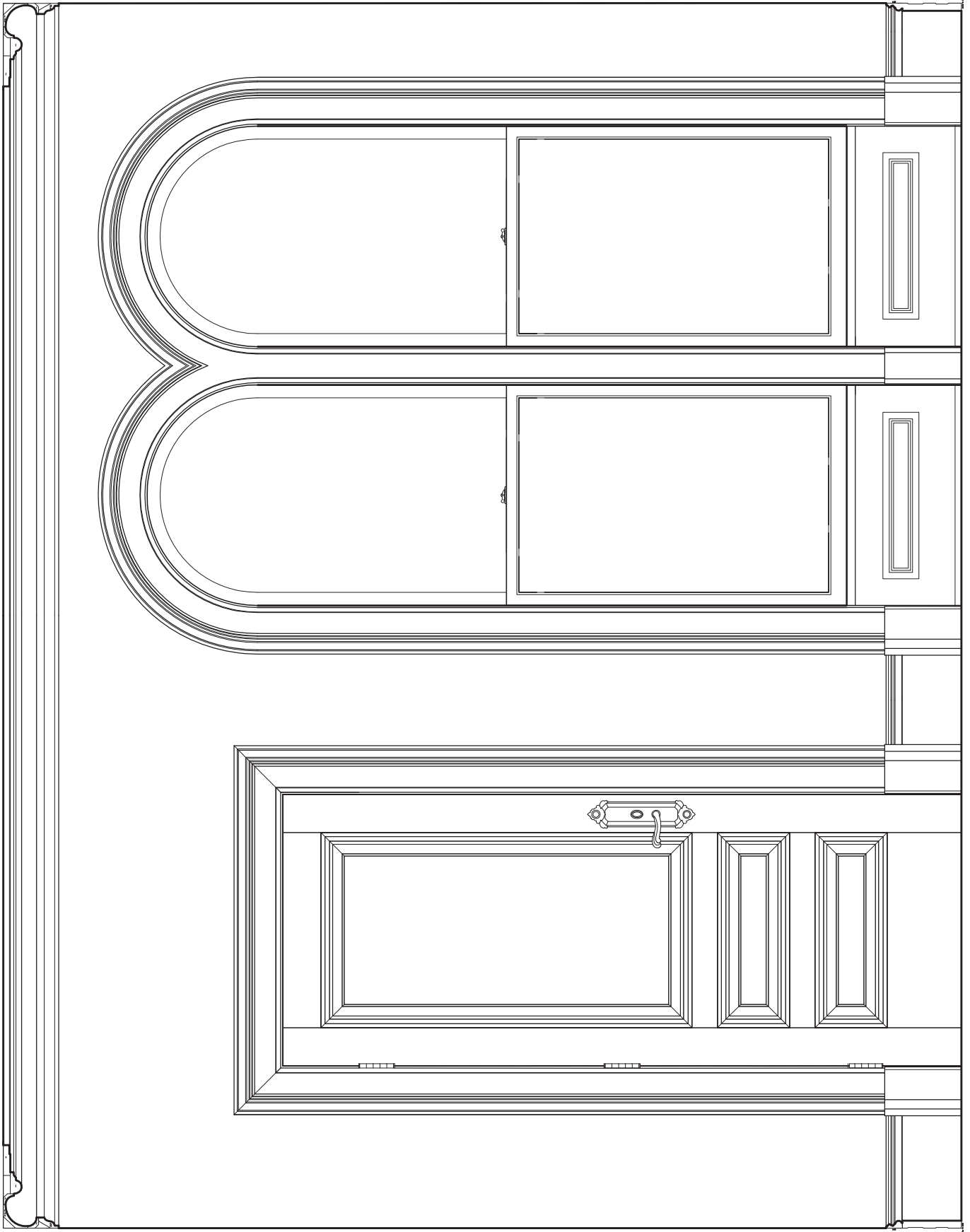

Drawing courtesy of The D. H. Ellison Co.

Scale: 3/4 inch = 1'

# Mid-Century Modern

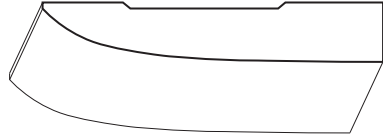

5215 [5/8 x 3-1/2]

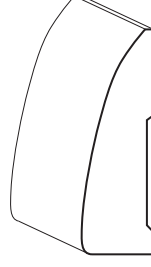

5215 [3/4 x 2-1/4]

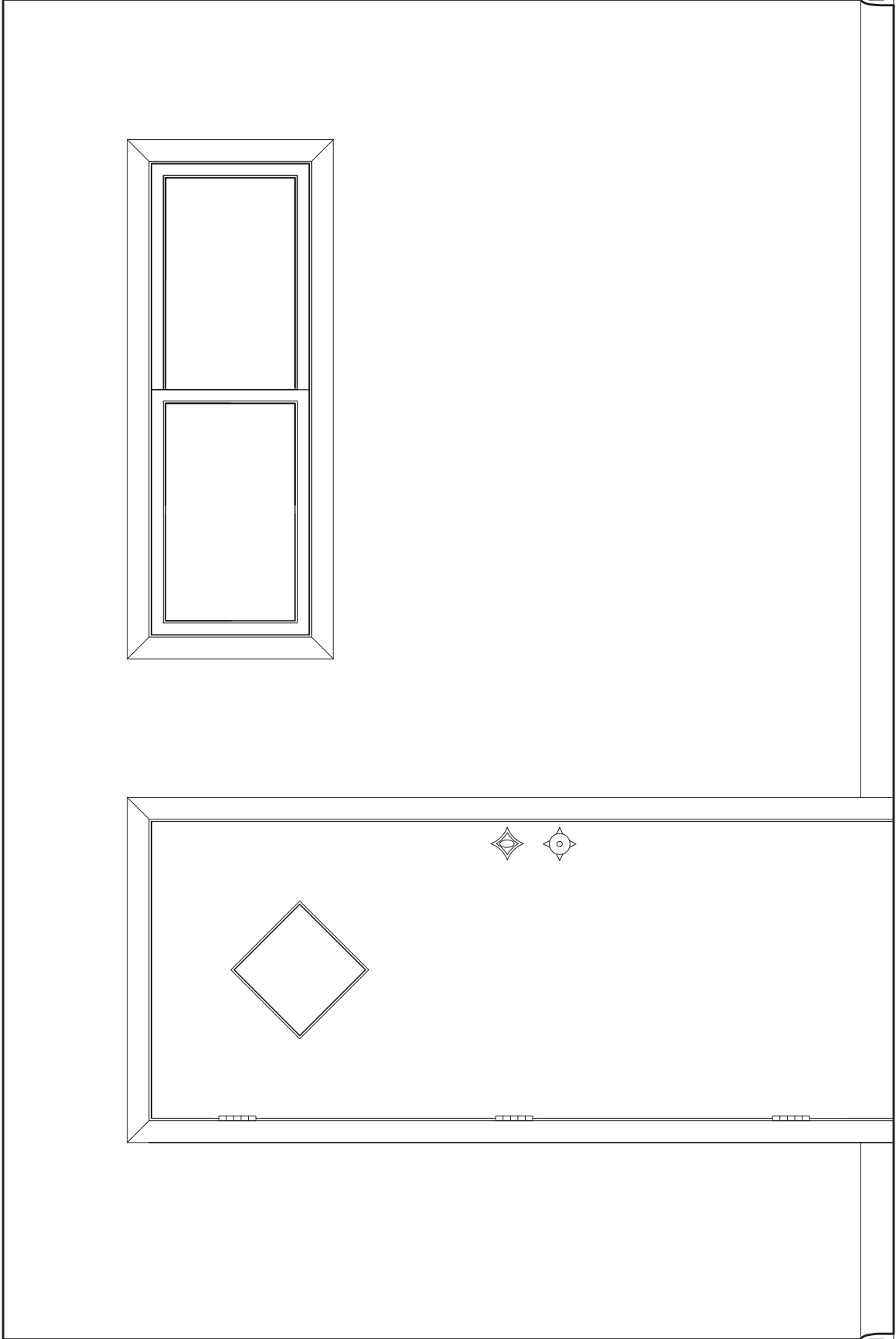

Drawing courtesy of The D. H. Ellison Co.

Scale: 3/4 inch = 1'

Moderne

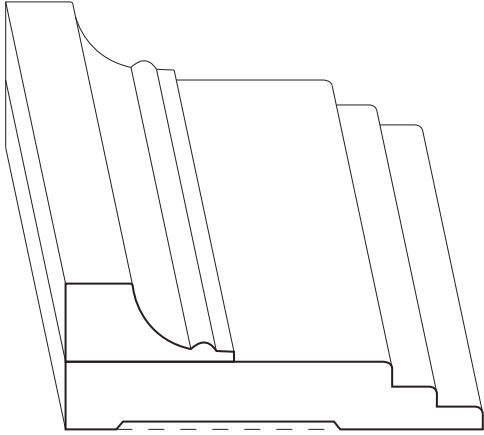

8039 [1-3/16 x 1-3/4]

2014 [11/16 x 4-3/8]

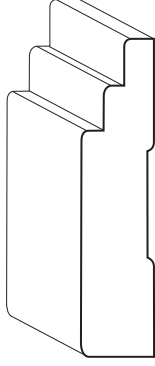

1021 [3/4 x 3-5/16]

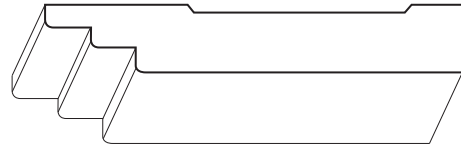

2014 [11/16 x 4-3/8]

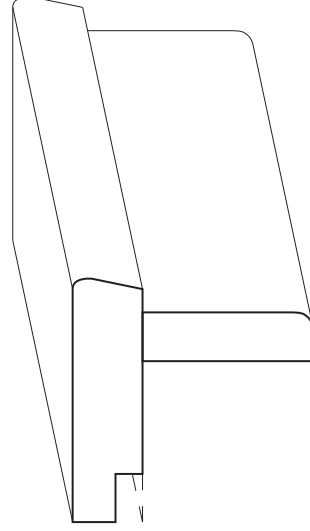

9001 [3/4 x 2-1/2]

5305 [1/2 x 1-3/4]



Drawing courtesy of The D. H. Ellison Co.

Scale: 3/4 inch = 1'

# Prairie

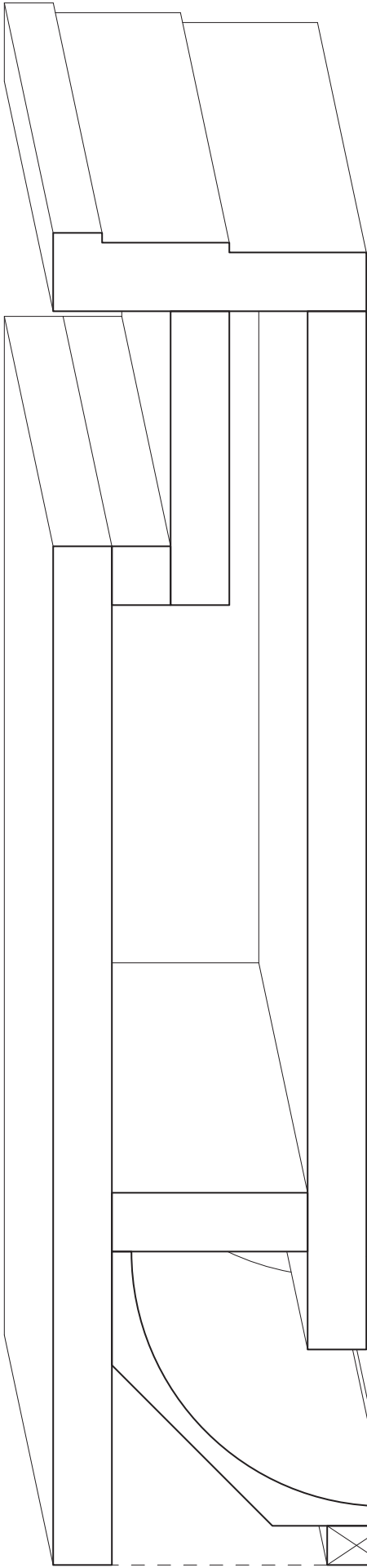

- Custom Casing [1 x 4]
- S4S [3/4 x 3-3/4]
- S4S [3/4 x 3/4]
- S4S [3/4 x 13]
- S4S [3/4 x 13]
- S4S [3/4 x 2-1/2]
- Custom Cove [1-1/4 x 5]
- Notched S4S [1 x 3/4]
- S4S [3/4 x 3-3/4]
- Custom Mold [5/8 x 2-1/4]

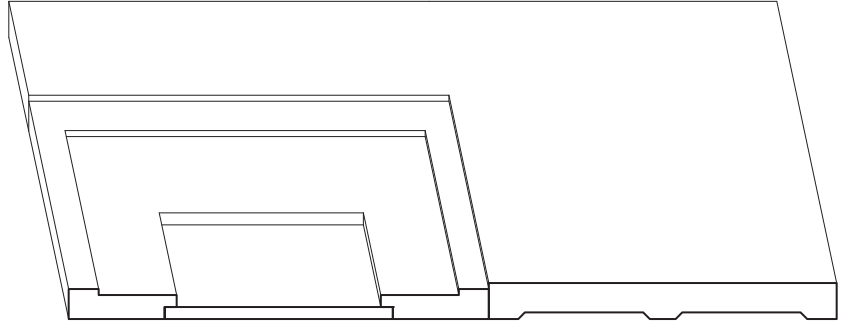

Custom Mold [5/8 x 2-1/4]  
1/4 Plywood  
S4S [3/4 x 7-1/4]  
(drawing 1/4 scale)

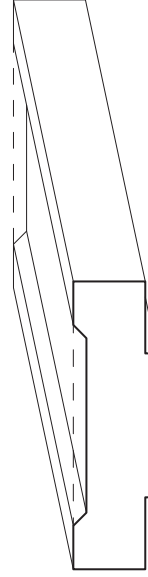

Custom Mold [7/8 x 3]

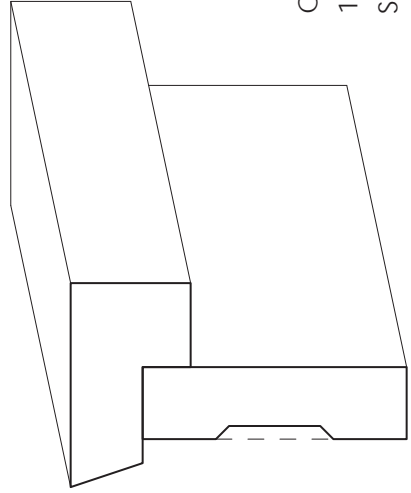

Notched S4S [1-1/4 x 2-1/4]  
S4S [3/4 x 2-1/2]

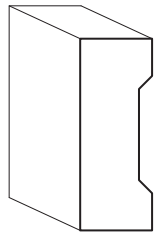

S4S [3/4 x 2]

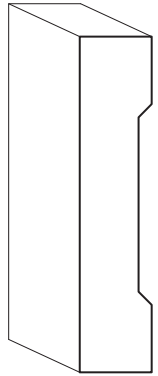

S4S [3/4 x 3-1/2]

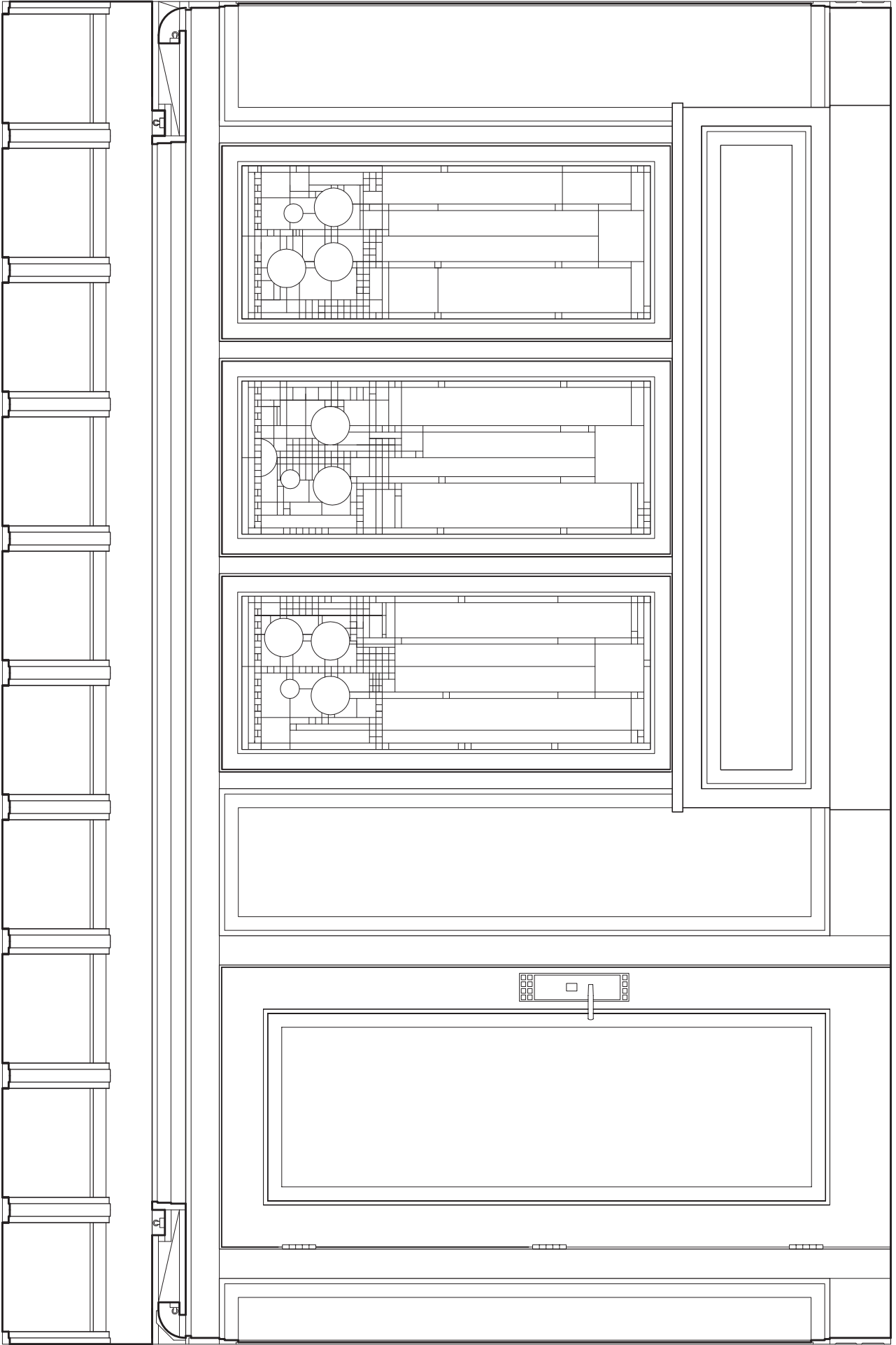

Drawing courtesy of The D. H. Ellison Co.

Scale: 3/4 inch = 1'

# Tudor

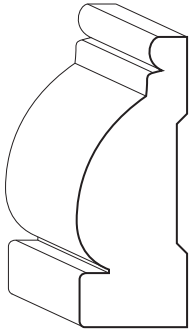

1157 [1-1/8 x 3]

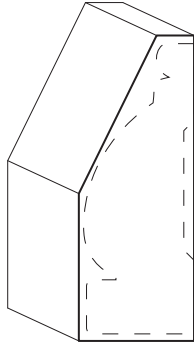

Custom Plinth [1-3/16 x 3-3/16]

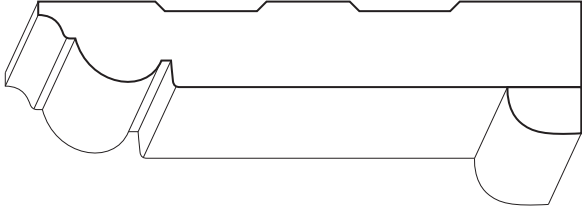

1126 [7/8 x 5-3/4]

5101 [1/2 x 3/4]

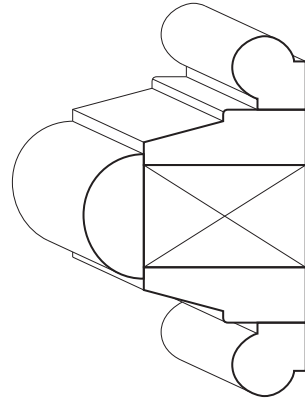

5007 [3/4 x 3/4]

8071 [9/16 x 1-11/16]

5210 [5/8 x 1-1/4]

8071 [9/16 x 1-11/16]

5007 [3/4 x 3/4]

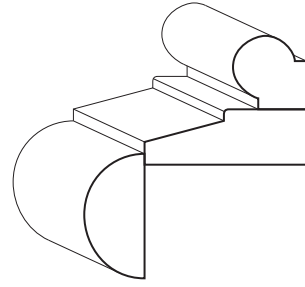

5210 [5/8 x 1-1/4]

8071 [9/16 x 1-11/16]

5007 [3/4 x 3/4]

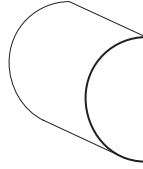

5210 [5/8 x 1-1/4]

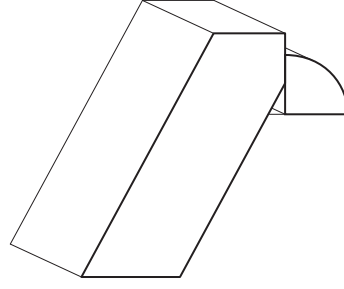

Custom Sill [7/8 x 3-1/4]

5020 [5/8 x 5/8]

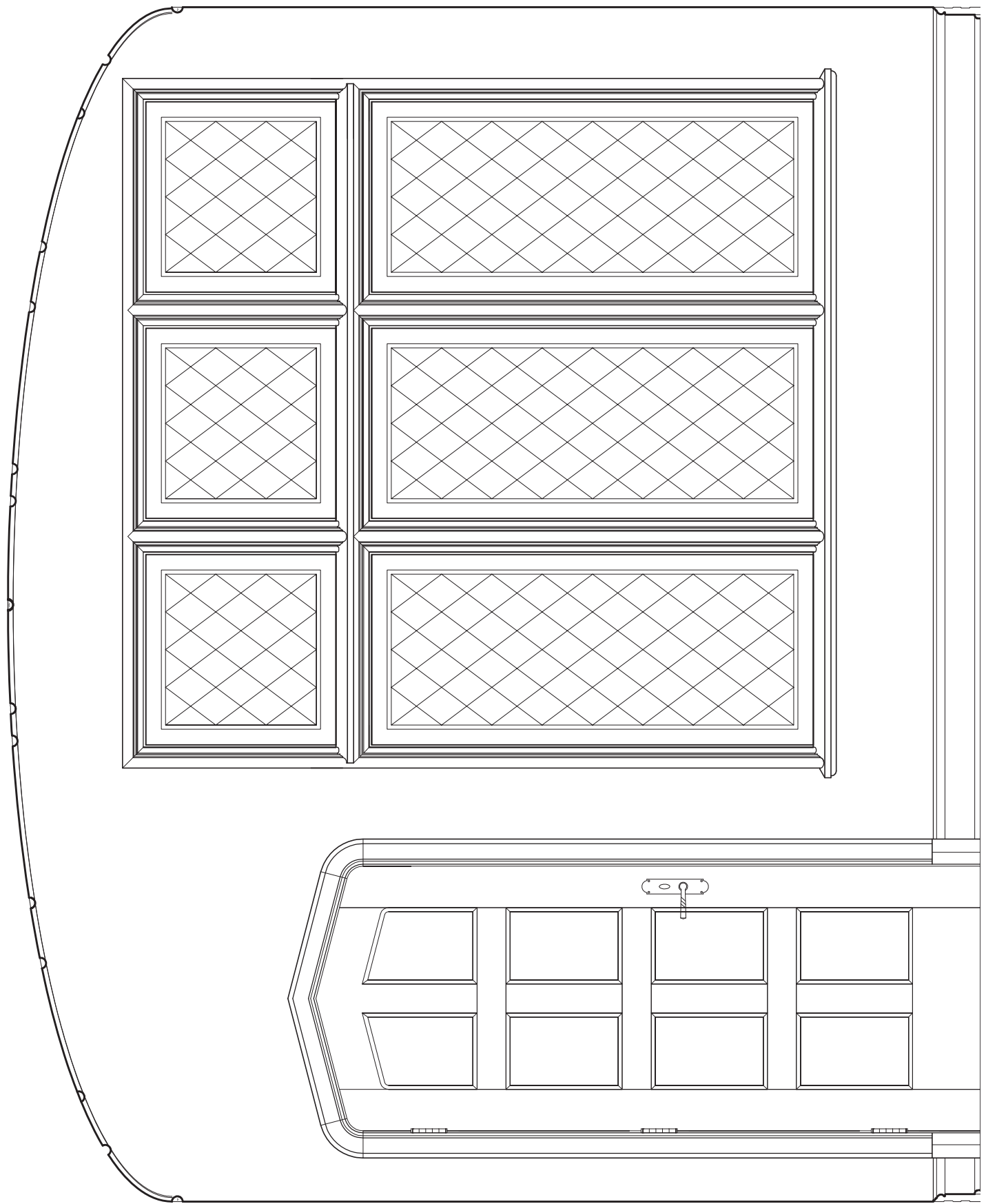

Scale: 3/4 inch = 1'

Drawing courtesy of The D. H. Ellison Co.

Victorian

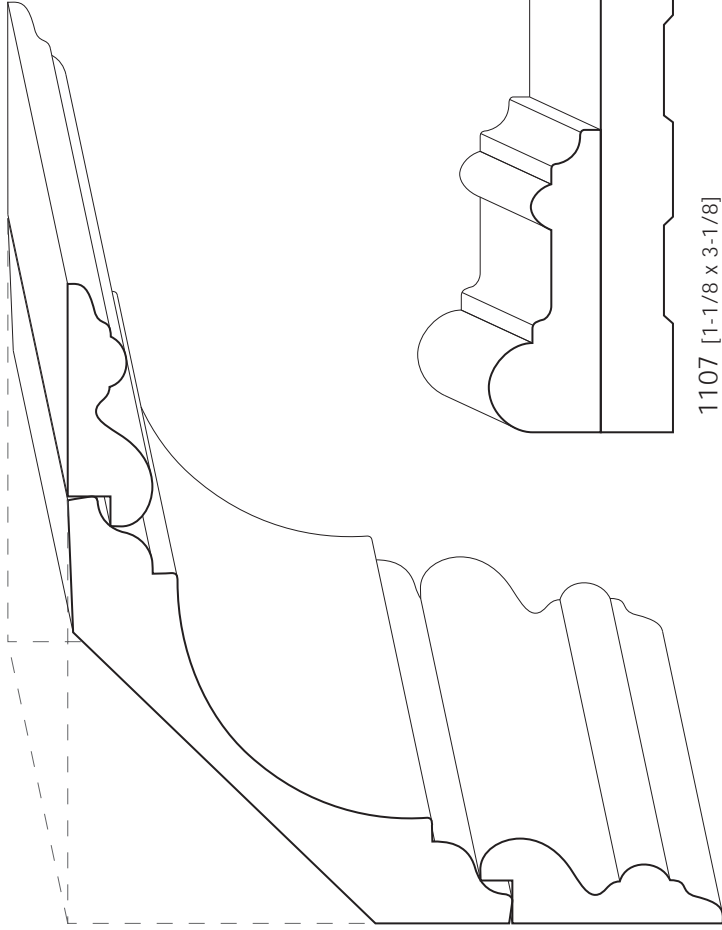

5230 [7/8 x 2-1/2]  
 3039 [1-1/4 x 6-1/4]  
 5230 [7/8 x 2-1/2]

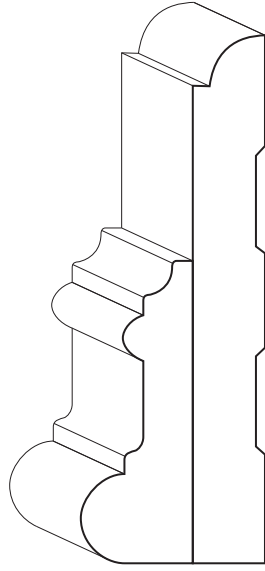

1107 [1-1/8 x 3-1/8]  
 2033 [3/4 x 5-1/2]

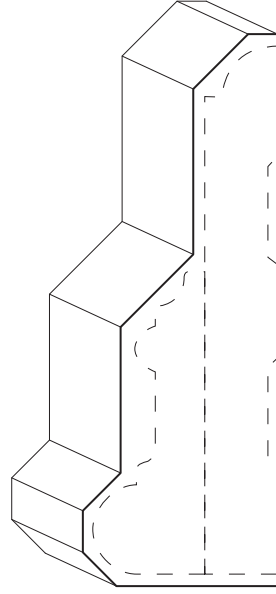

Custom Plinth [2 x 5-3/4]

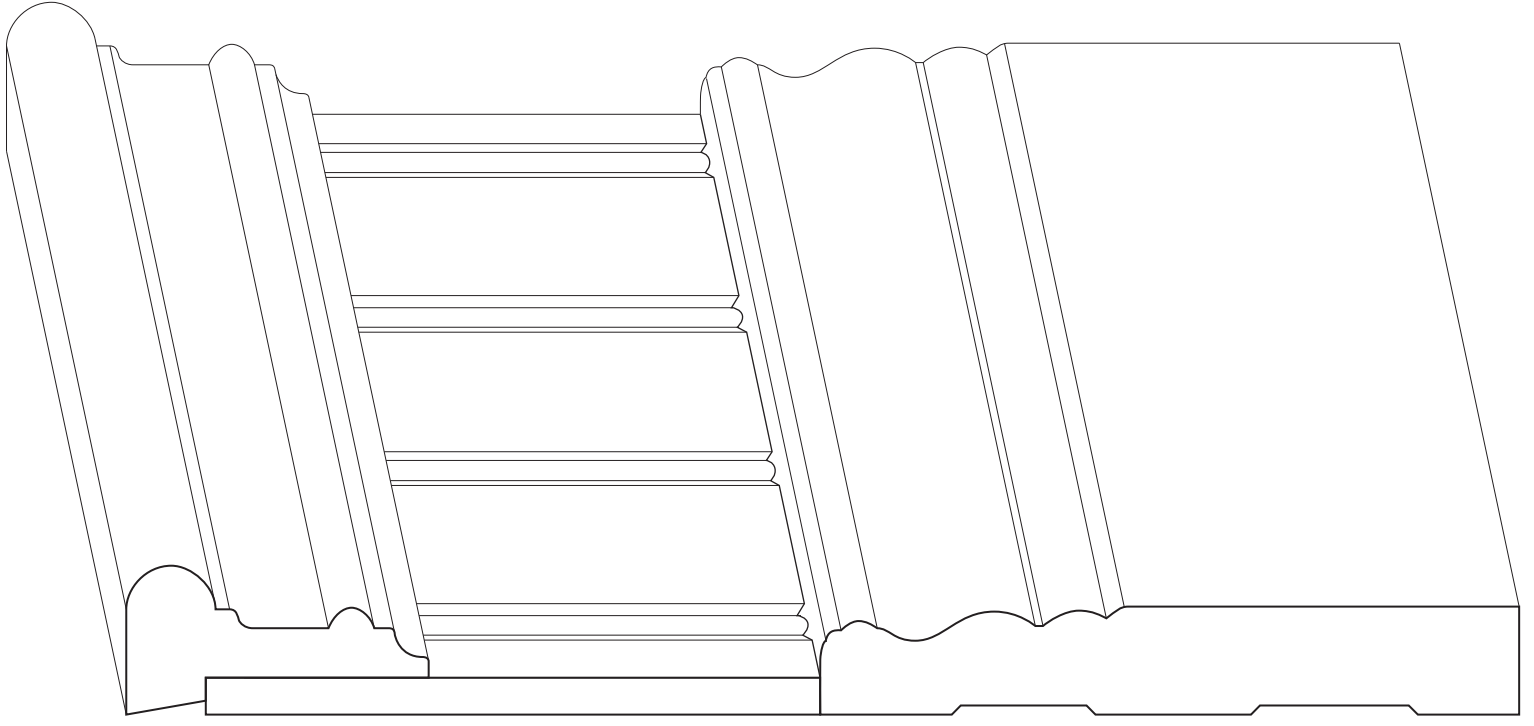

1107 [1-1/2 x 3-1/8]  
 8906 [3/8 x 3-1/4]  
 2055 [1-1/8 x 7-1/4]

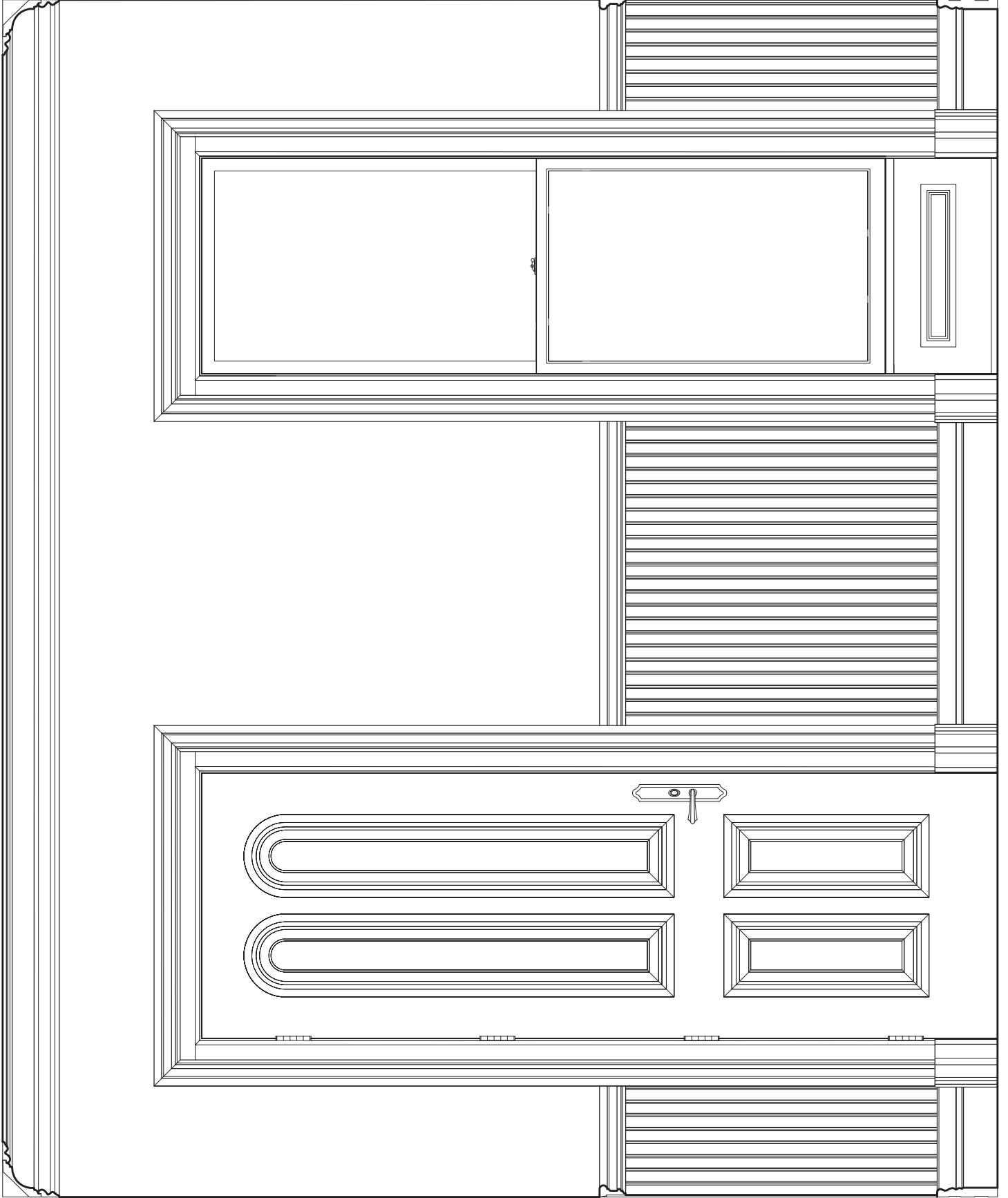



## Neoclassical

Neoclassical architecture was an architectural style produced by the neoclassical movement that began in the mid-18th century. In its purest form it is a style principally derived from the architecture of Classical Greece and the architecture of the Italian architect Andrea Palladio.

To view some notable examples of Neoclassical Architecture, we invite you to view architect David Ellison's portfolio at [www.dhellison.com](http://www.dhellison.com).

David Ellison is a practitioner of architecture located in the Ohio City district of Cleveland, Ohio.

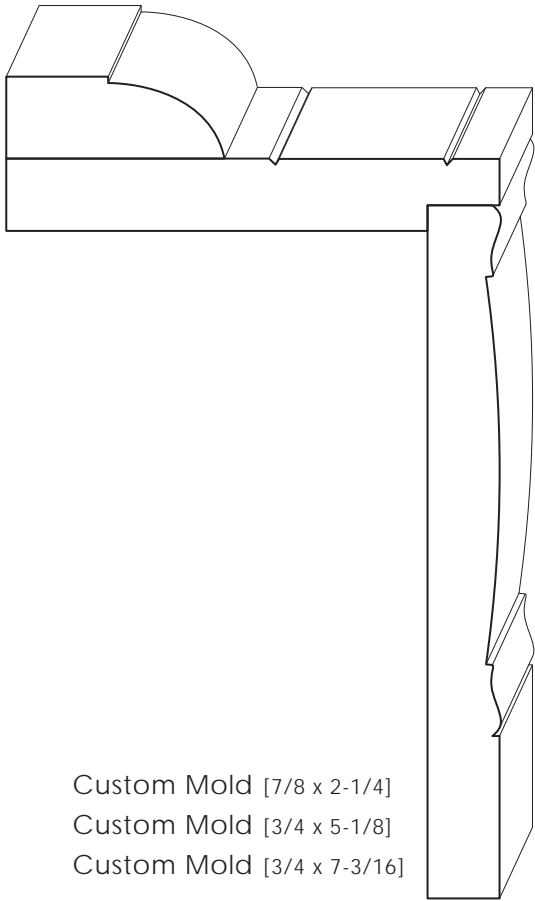

Custom Mold [7/8 x 2-1/4]  
 Custom Mold [3/4 x 5-1/8]  
 Custom Mold [3/4 x 7-3/16]

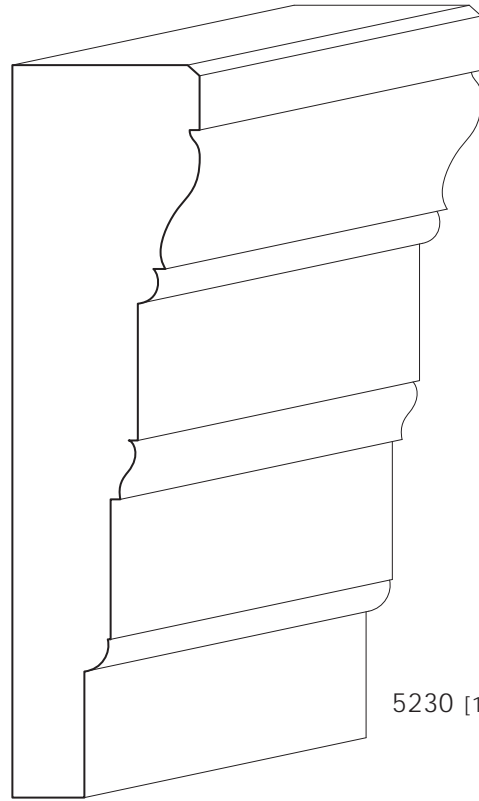

5230 [1-15/16 x 7-5/8]

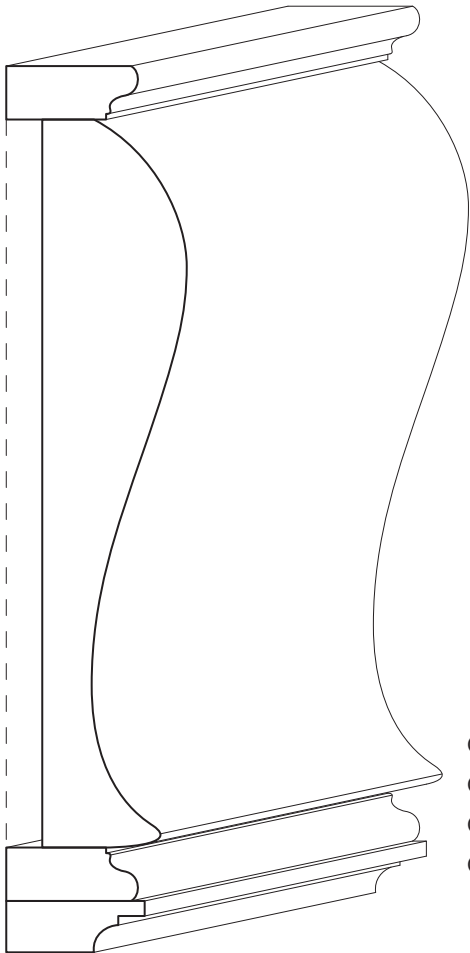

Custom Mold [9/16 x 1-3/8]  
 Custom Mold [1-7/8 x 7-1/2]  
 Custom Mold [9/16 x 1-3/8]  
 Custom Mold [9/16 x 1-7/16]

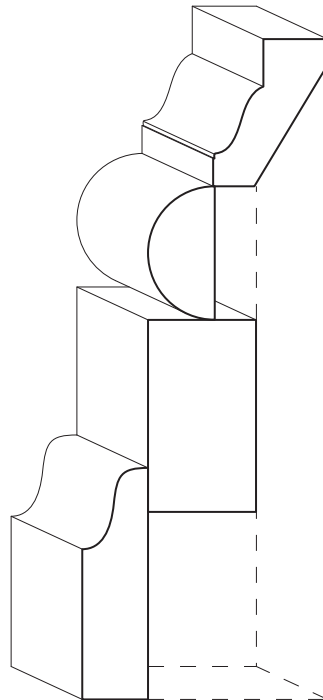

Custom Mold [1-1/8 x 1-1/2]  
 Custom Mold [3/4 x 1-3/8]  
 Custom Mold [1-1/8 x 2]  
 Custom Mold [11/16 x 2-3/8]

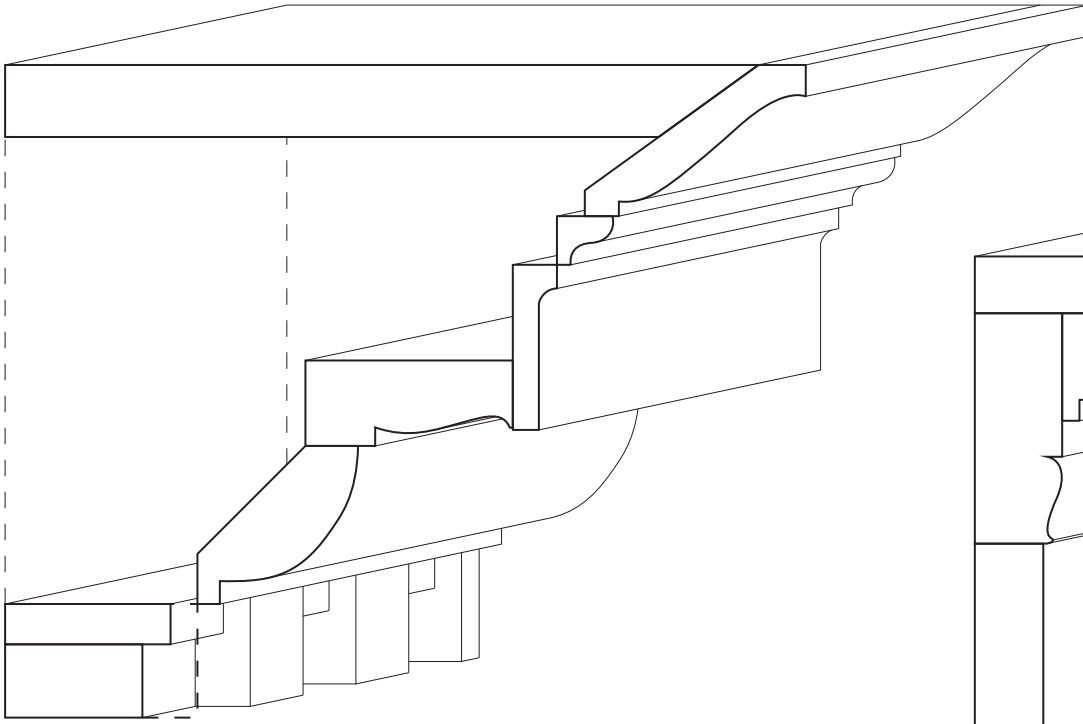

Custom Crown [1/2 x 2-3/4]

Custom Mold [1/2 x 9/16]

Custom Mold [1/2 x 1-3/4]

Custom Mold [7/8 x 2-1/8]

Custom Crown [7/8 x 2-3/8]

Custom Dentil [1 x 2]

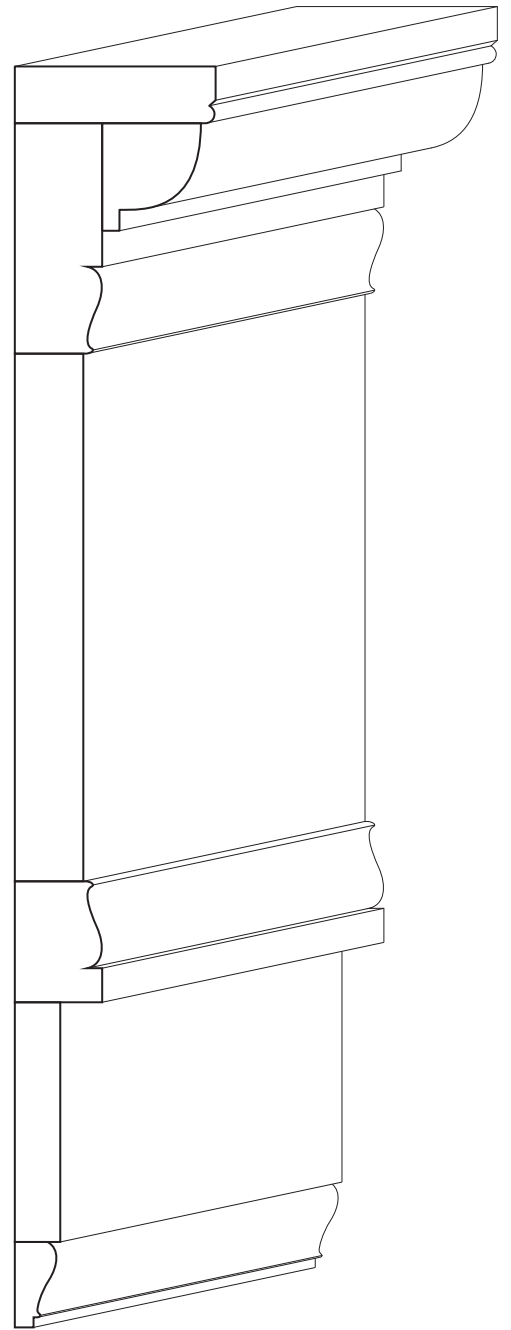

Custom Mold [5/8 x 2-1/8]

Custom Mold [1-1/16 x 1-1/8]

Custom Mold [7/8 x 2-3/8]

S4S [3/4 x 5-1/2]

Custom Mold [7/8 x 1-1/4]

S4S [1/2 x 2-1/2]

Custom Mold [1/2 x 7/8]

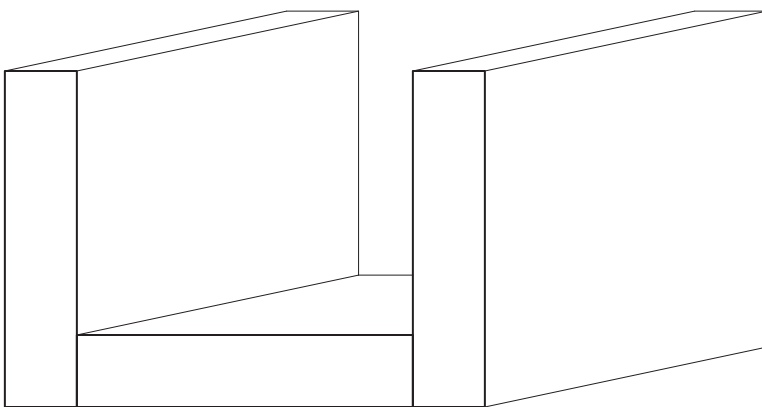

S4S [3/4 x 3-1/2]

S4S [3/4 x 3-1/2]

S4S [3/4 x 3-1/2]



Brazilian Cherry

Hardness 2350



Ash

Hardness 1320



Lyptus

Hardness 2228



Beech

Hardness 1300



Santos Mahogany

Hardness 2200



Red Oak

Hardness 1290



Hickory/Pecan

Hardness 1820



Birch

Hardness 1260



Hard Maple

Hardness 1450



Walnut

Hardness 1010

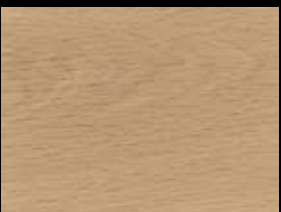

White Oak

Hardness 1360



Sassafras

Hardness 1000



Cherry

Hardness 950



Knotty Alder

Hardness 590



Curly Maple

Hardness (see Soft or Hard Maple)



Poplar

Hardness 540



Soft Maple

Hardness 950



Basswood

Hardness 410

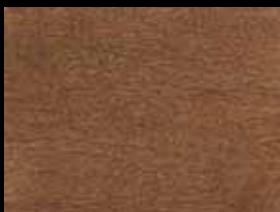

Honduras Mahogany

Hardness 800



Knotty Pine

Hardness 380



African Mahogany

Hardness 800



Clear Pine

Hardness 380

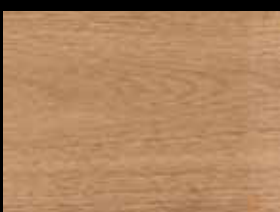

Spanish Cedar

Hardness 600

## S4S

S4S (surfaced-four-sides) is dimensioned lumber that has all the faces and edges moulded and one face sanded smooth. To the right are the sizes inventoried in Poplar, Maple, and Red Oak. Custom thicknesses, sizes, and hardwood species are available.

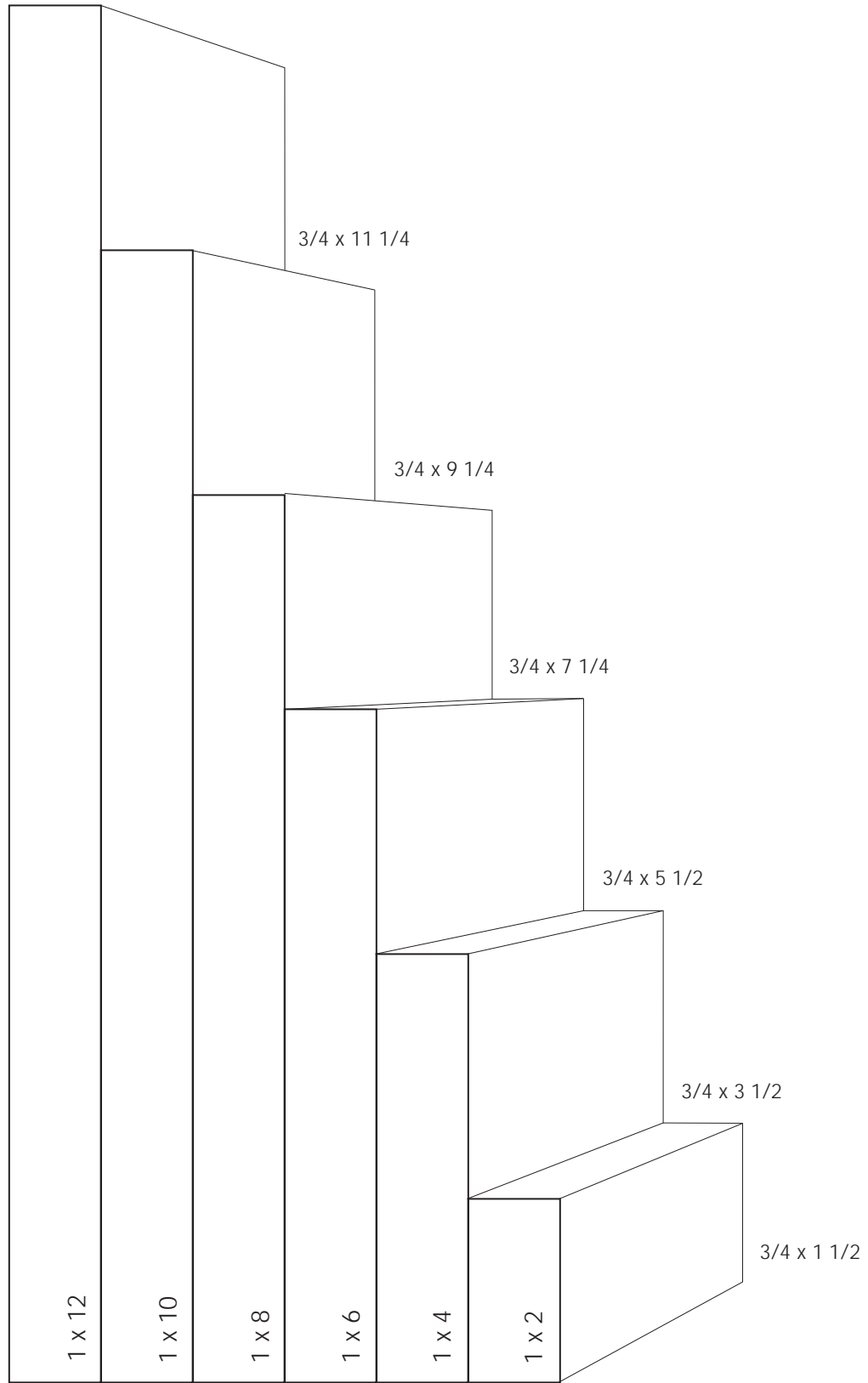

Casing  
[in stock]

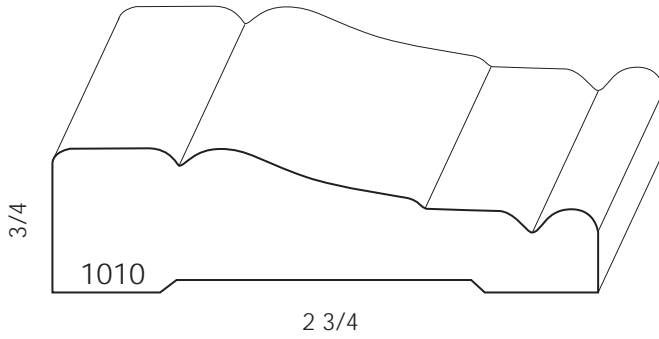
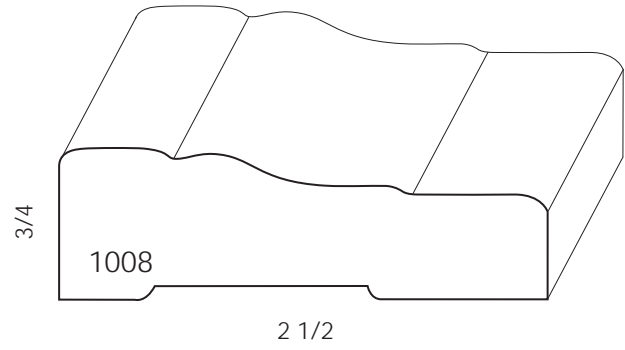
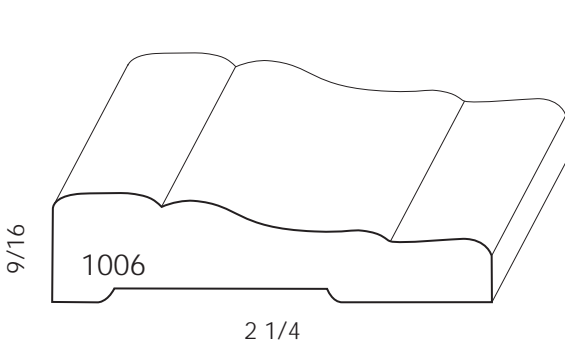
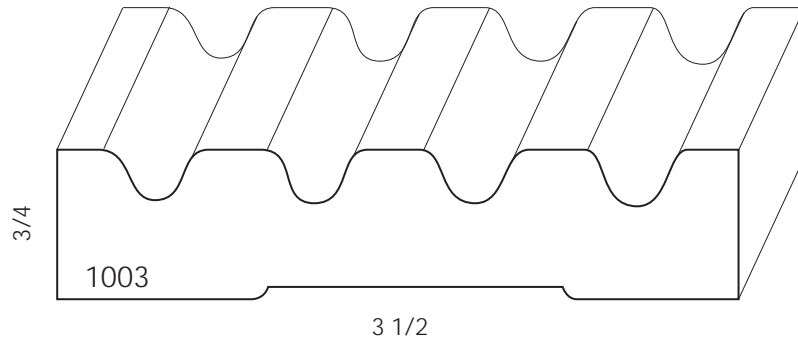

Mouldings shown are inventoried in Poplar and Red Oak in lengths up to 16'. Profile designs 1010, 1011, 2005, and 2007 are also inventoried in Maple.

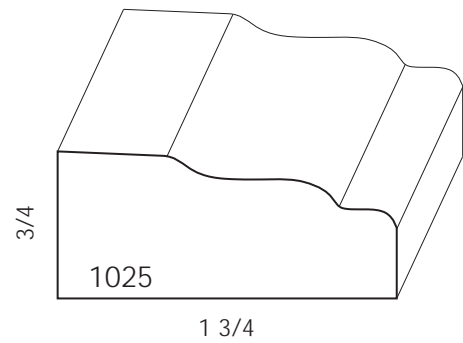
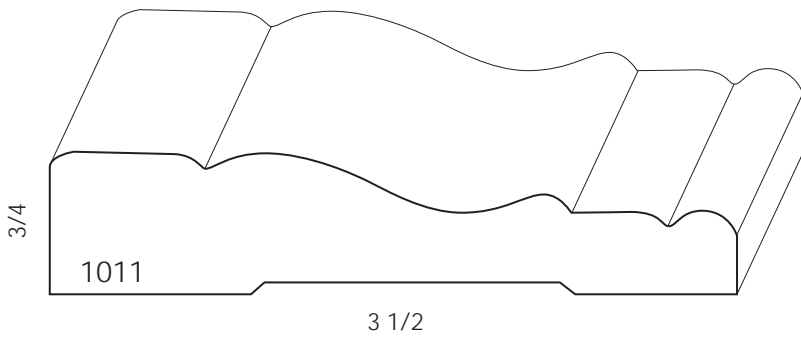

Base  
[in stock]

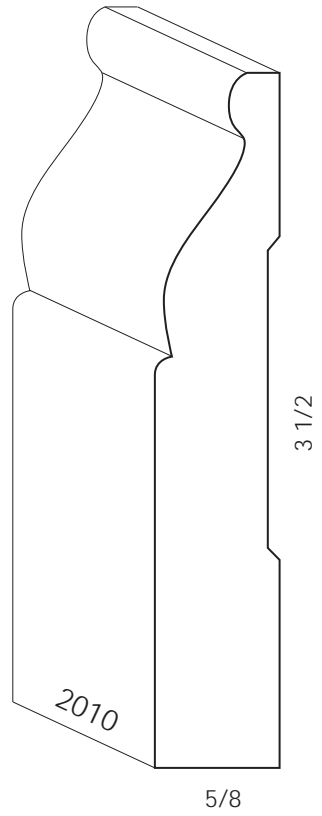
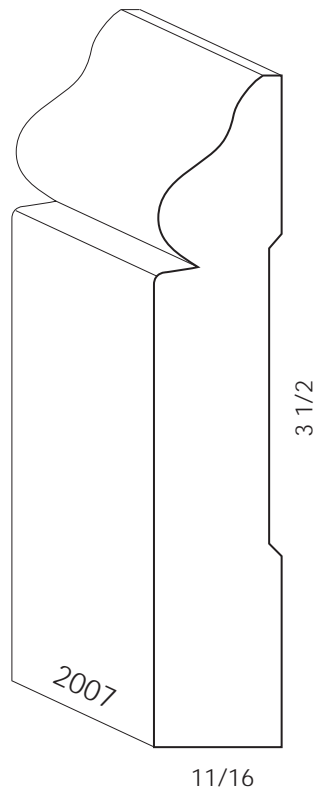
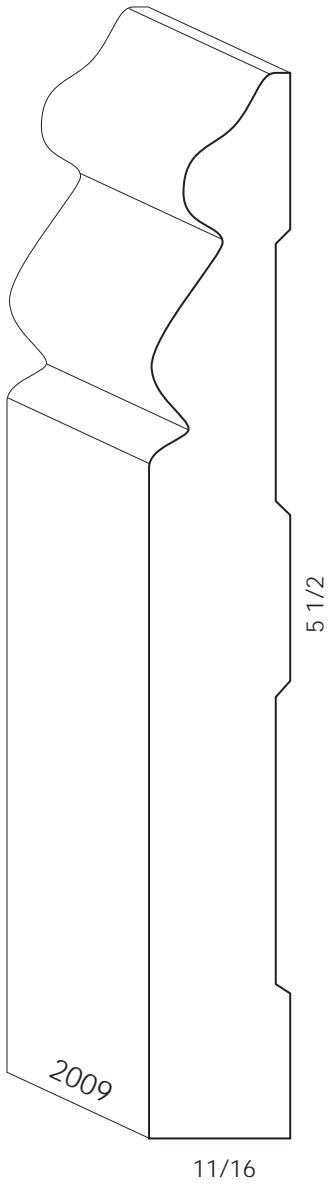
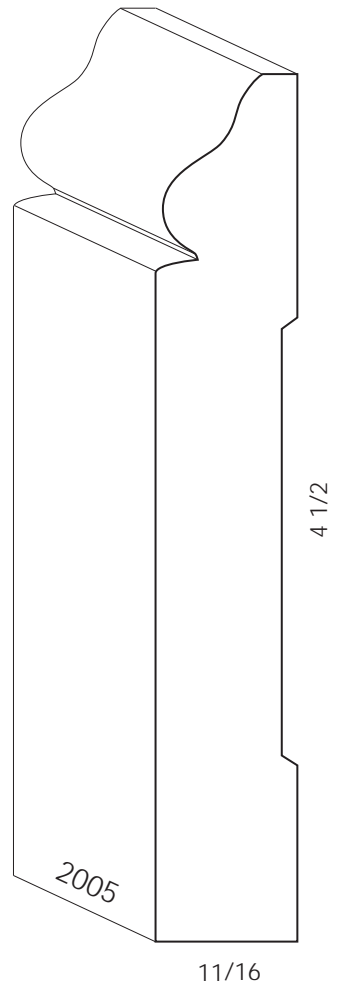
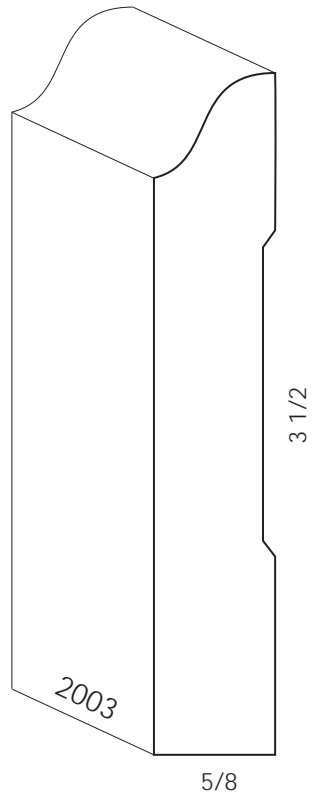
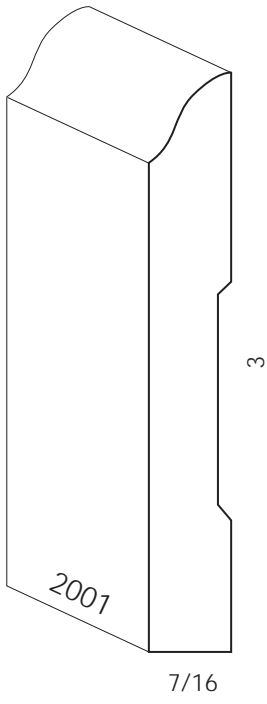

Crown  
[in stock]

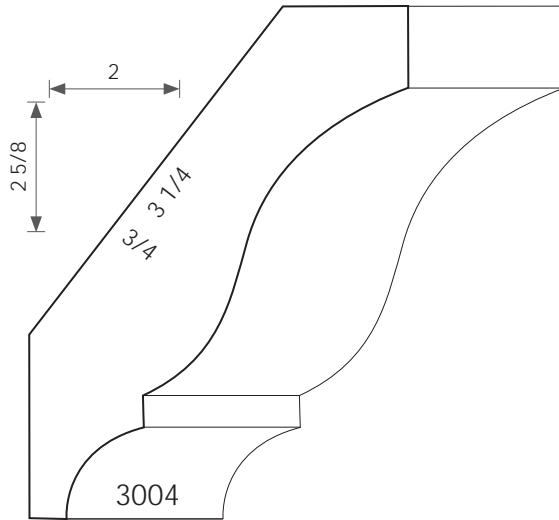
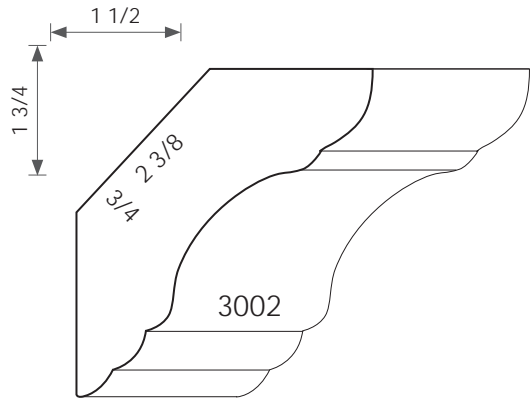
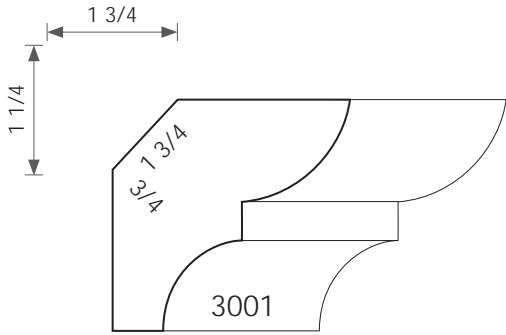

Mouldings shown are inventoried in Poplar and Red Oak in lengths up to 16'. Profile designs 3001, 3002, 3004, and 3101 are also inventoried in Maple.

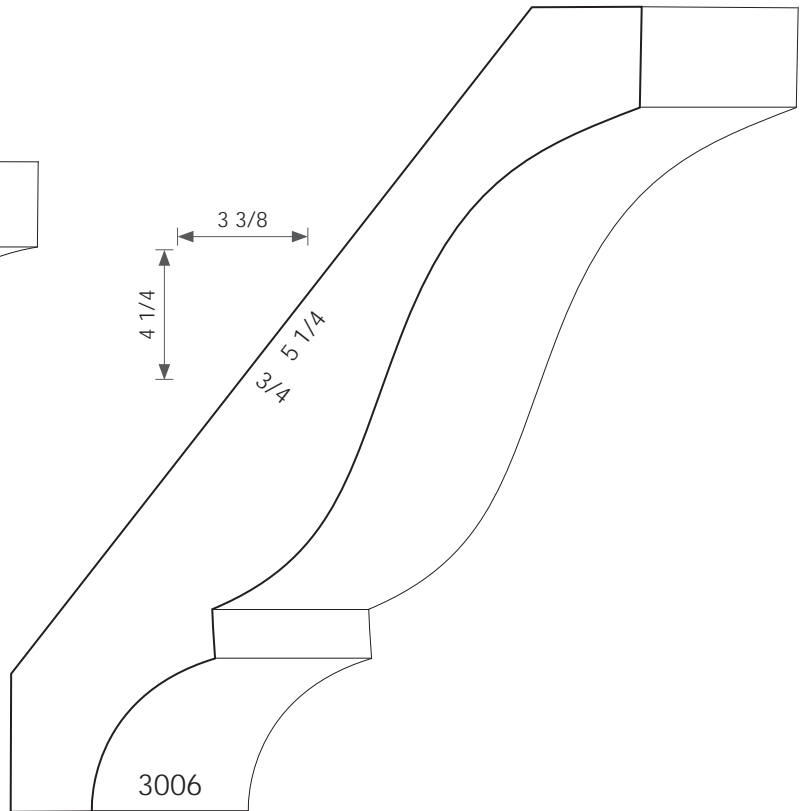
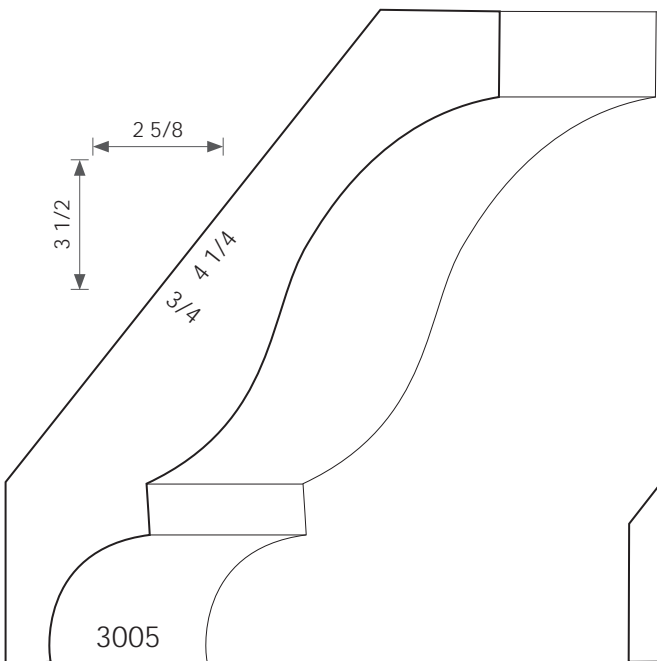

Cove  
[in stock]

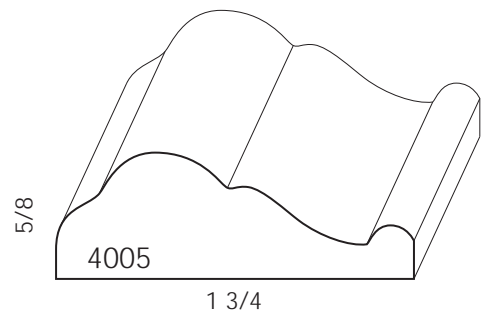
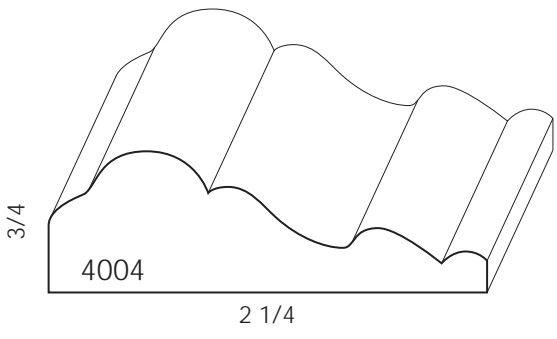
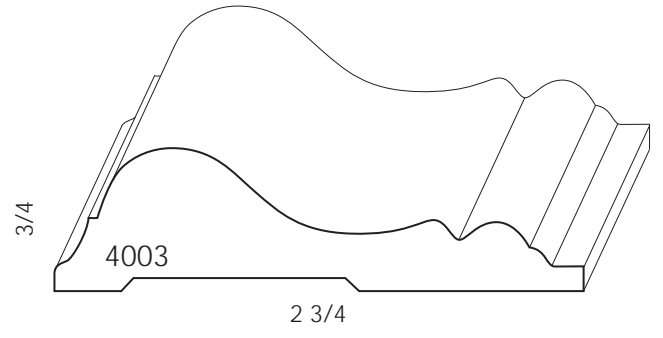
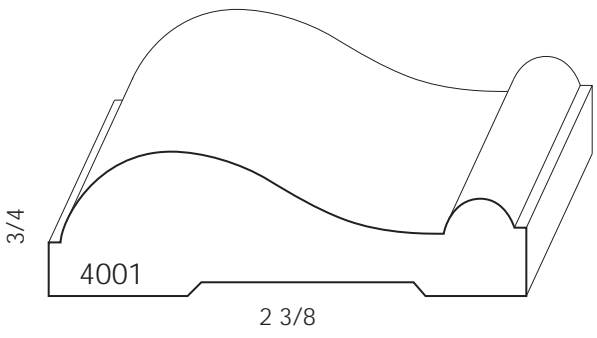
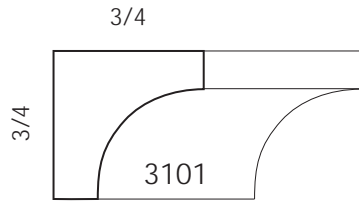

Chair Rail  
[in stock]

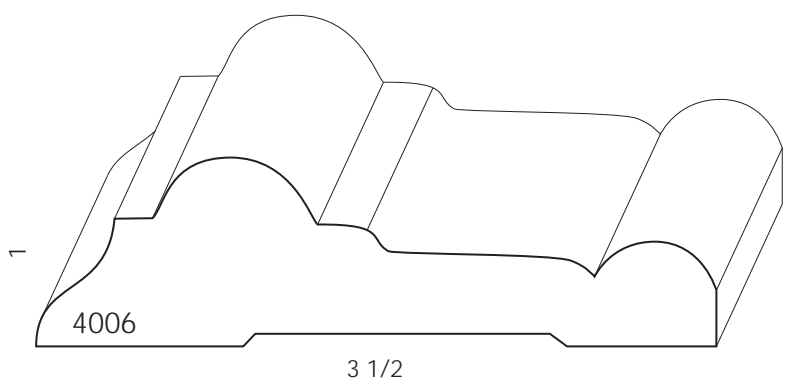

# Small Mold

[in stock]

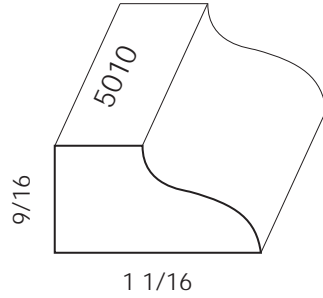
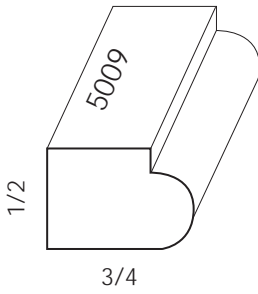
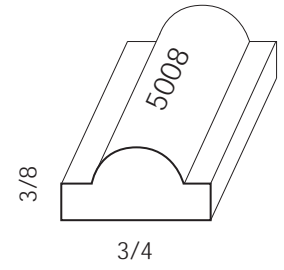
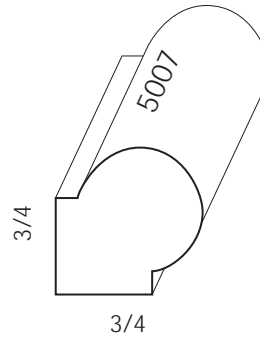
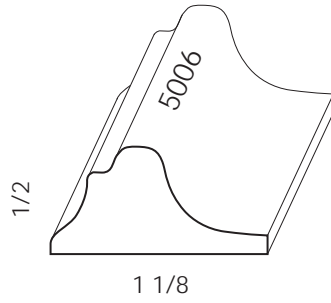
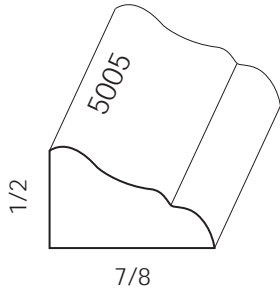
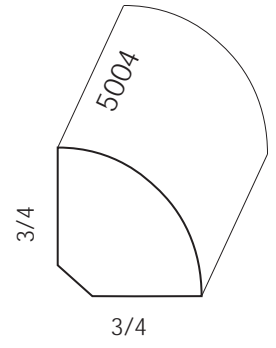
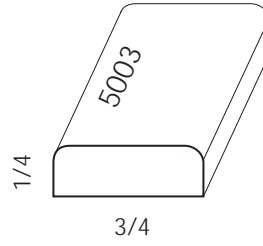
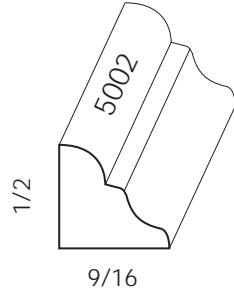
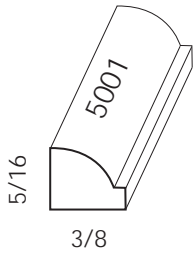

Mouldings shown are inventoried in Poplar and Red Oak in lengths up to 16'. Profile designs 5001, 5002, 5003, 5004, 5005, 5006, 5007, 5008, 5009, 5010, 5101, 5201, 5203, 5203, 5301, 5401, and 5402 are also inventoried in Maple.

# Shoe

[in stock]

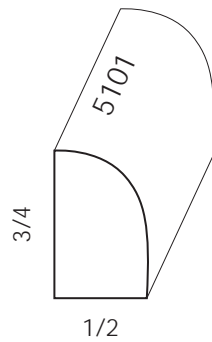

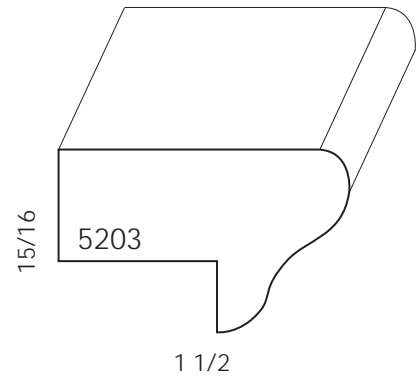
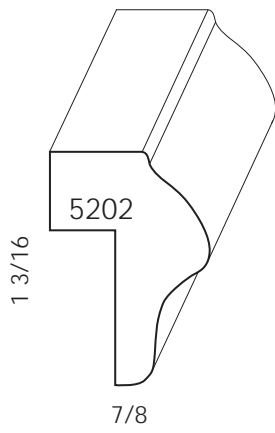
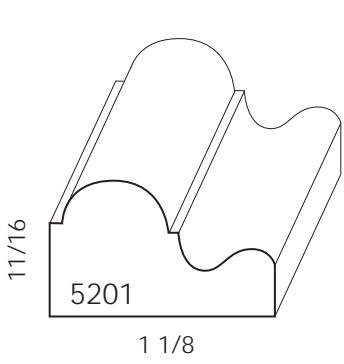

Panel Mold  
[in stock]

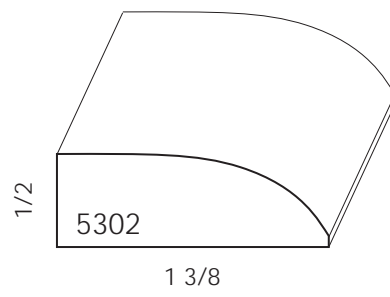
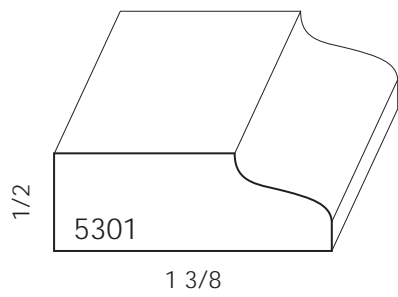
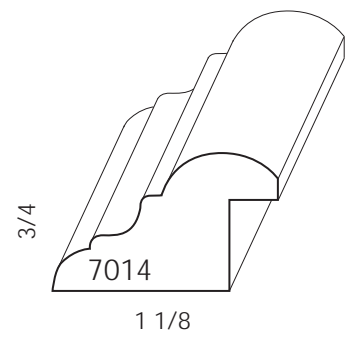
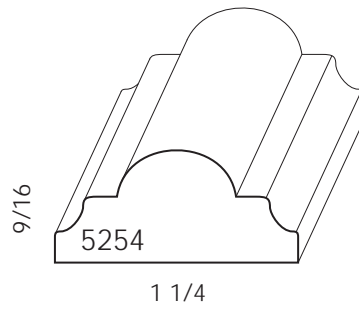
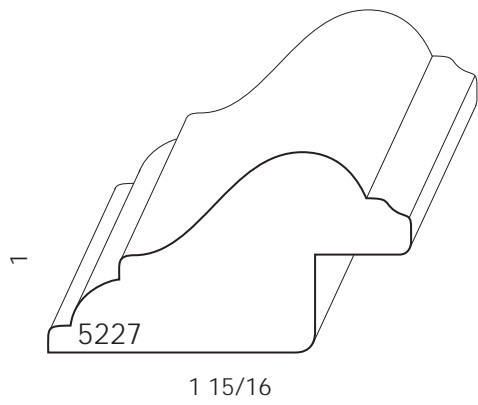

Door Stop  
[in stock]

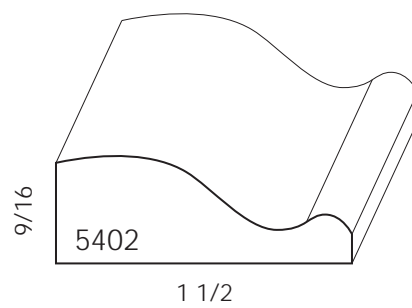
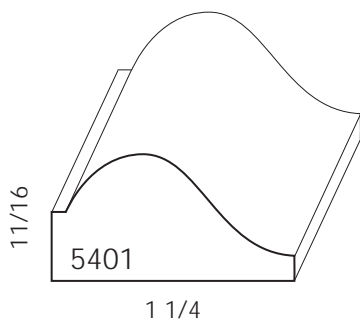

Base Cap  
[in stock]

# Outside Corner

[in stock]

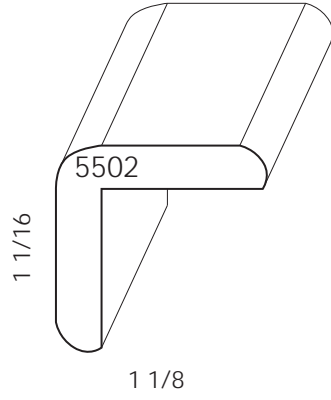
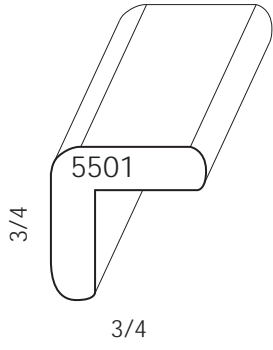

Moldings shown are inventoried in Poplar and Red Oak in lengths up to 16'.

# Handrail

[in stock]

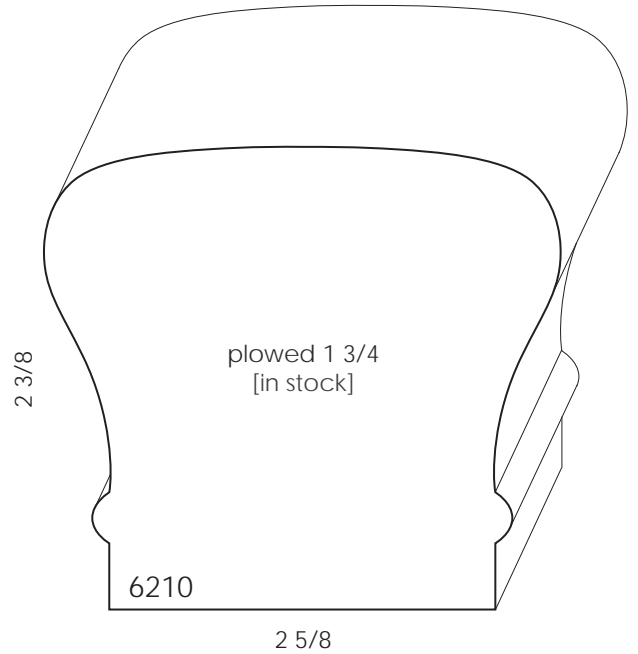
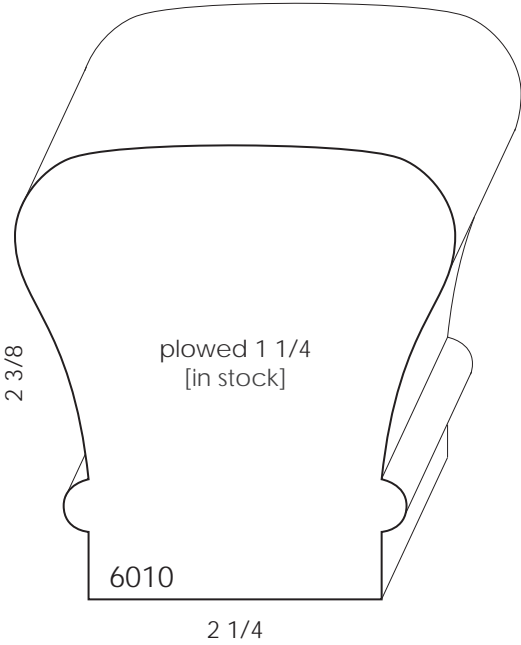

Handrail  
[in stock]

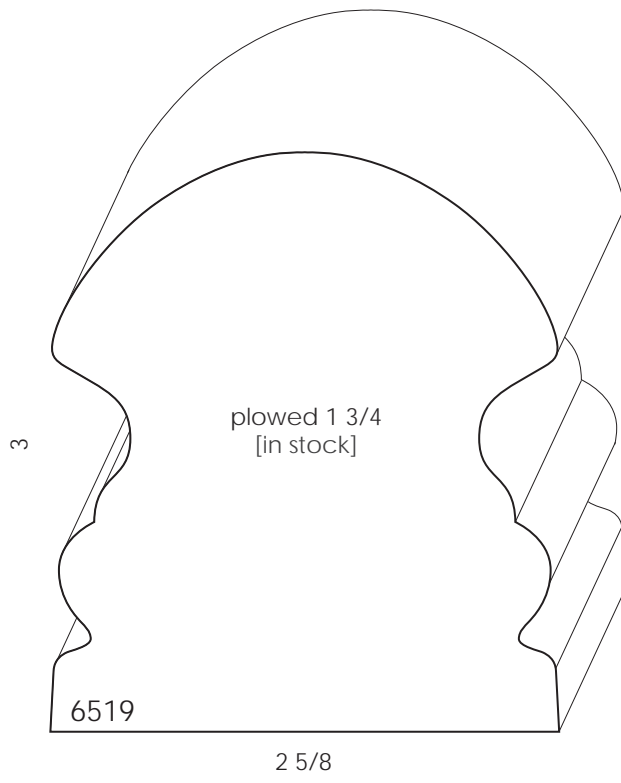

Shoerail  
[in stock]

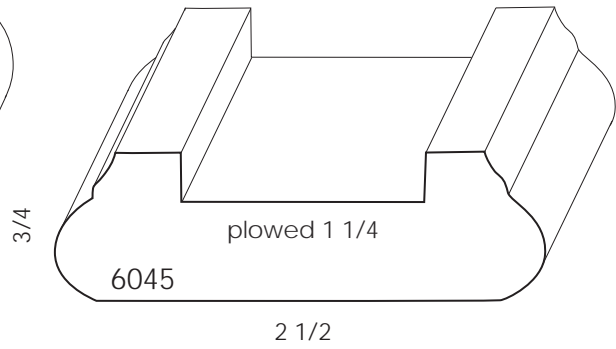
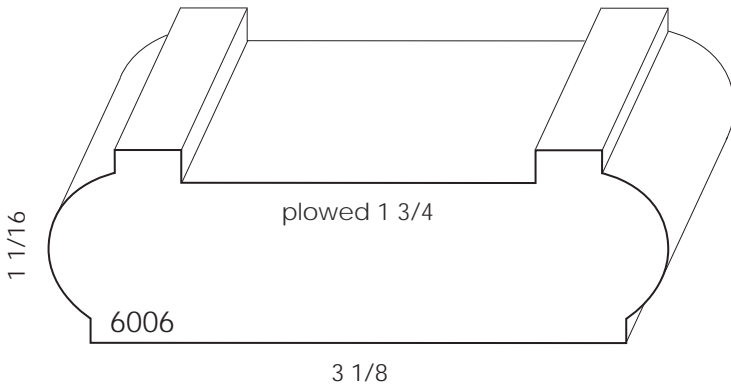

Fillet  
[in stock]

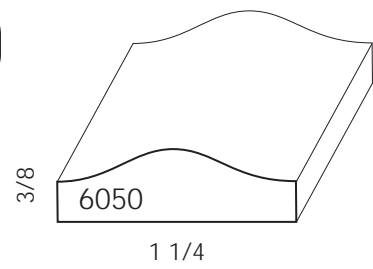
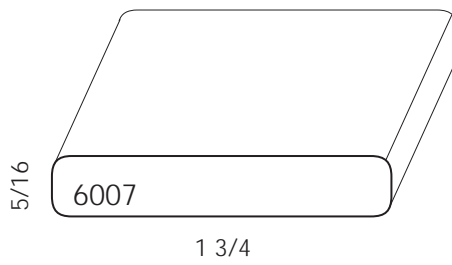
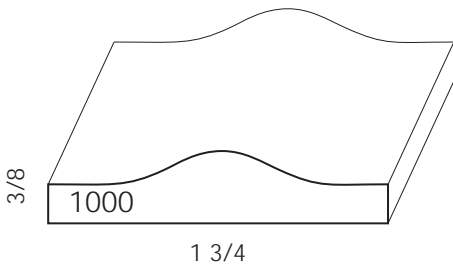

# Back Band

[in stock]

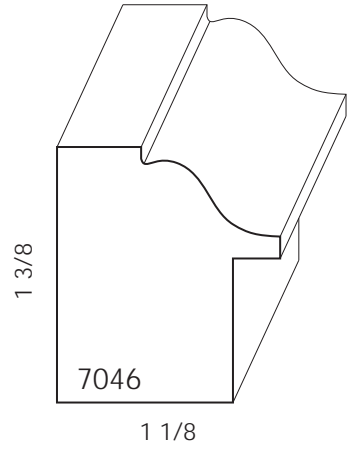
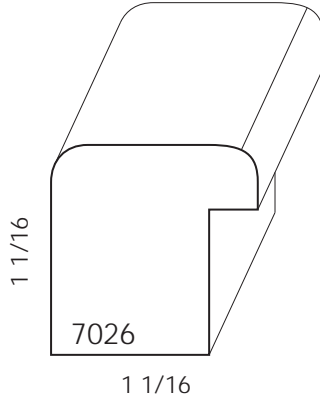
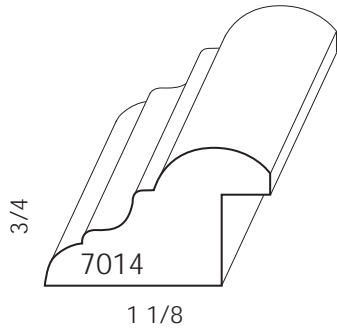

# Window Sill

[in stock]

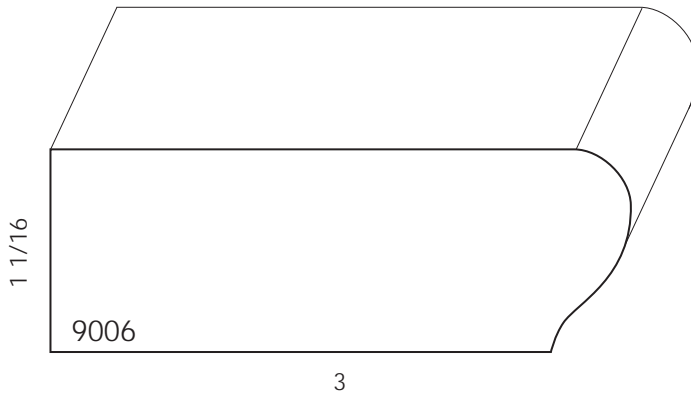
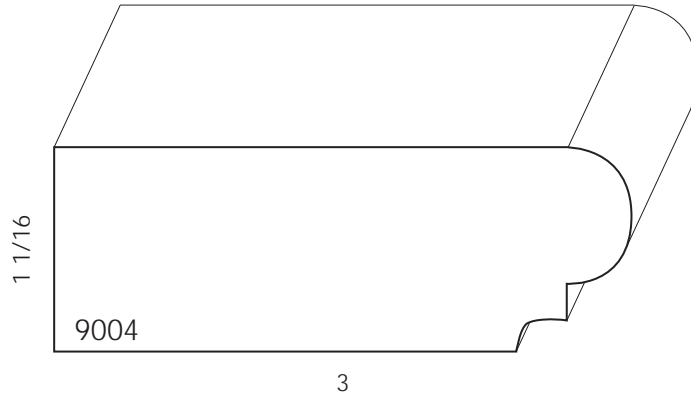

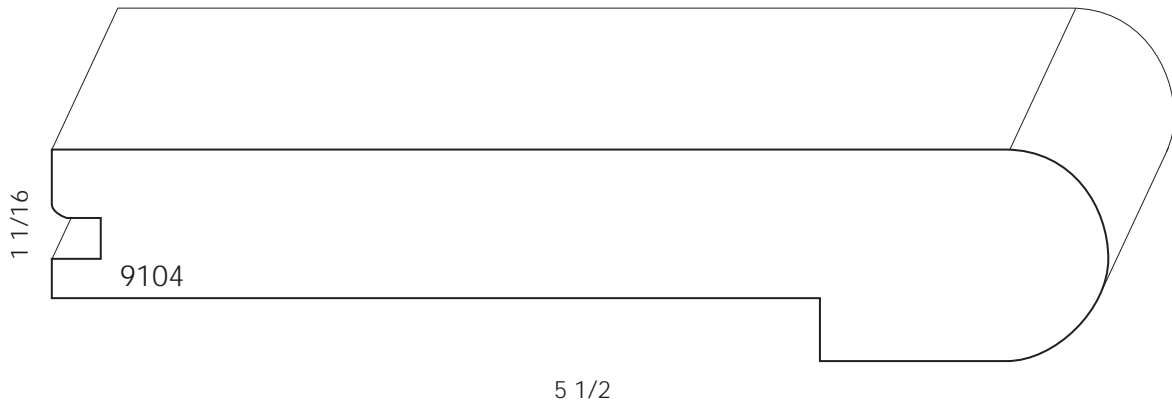
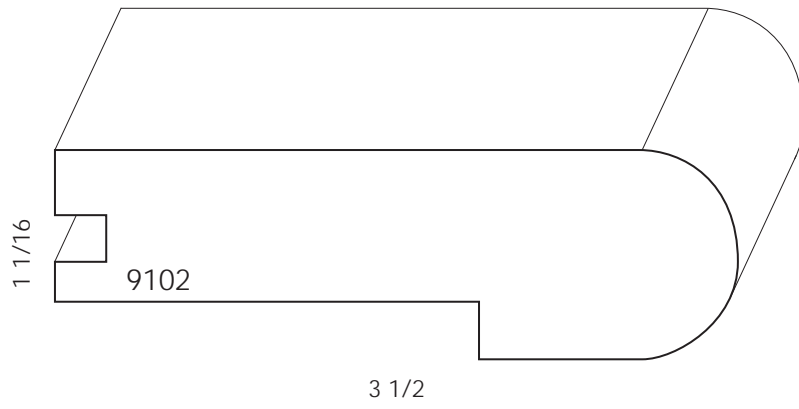

Mouldings shown are inventoried in Poplar and Red Oak (7026 and 7046 are not inventoried in Red Oak) in lengths up to 16'. Profile designs 9102 and 9104 are also inventoried in Maple.

Casing

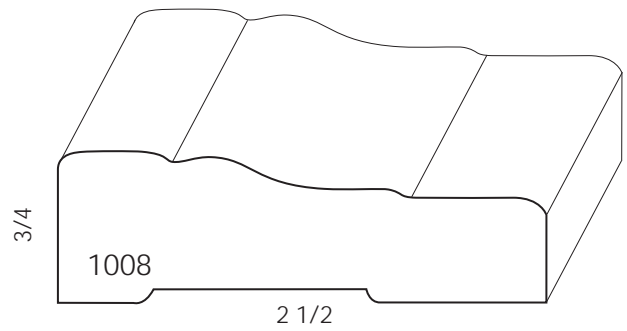
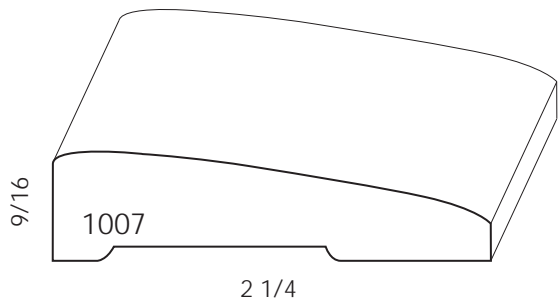
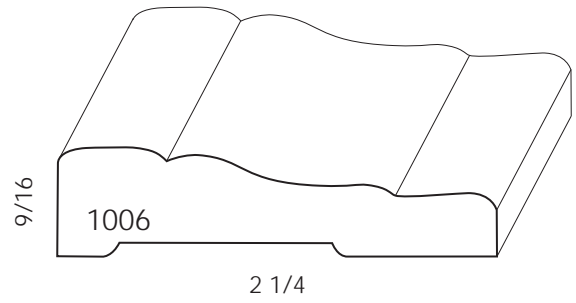
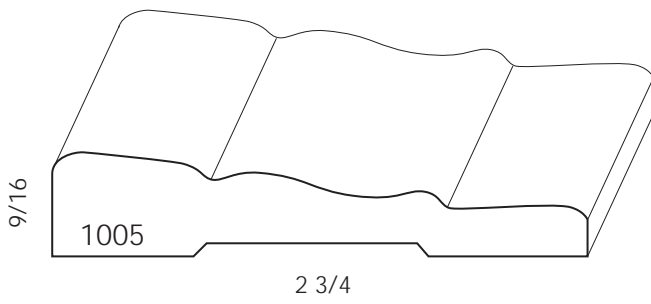
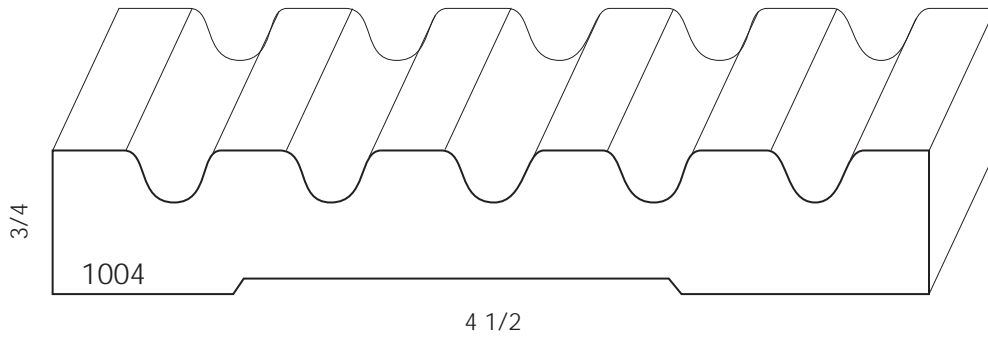
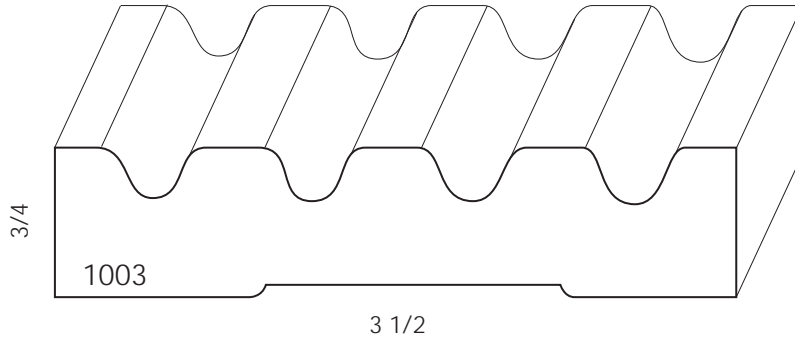
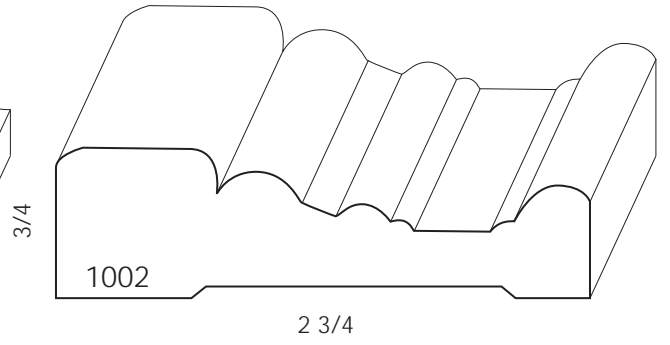
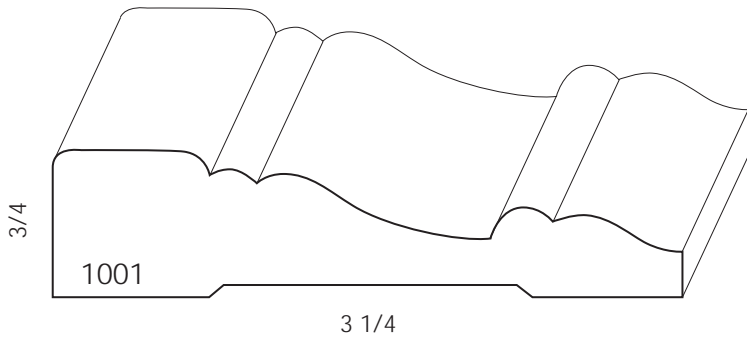

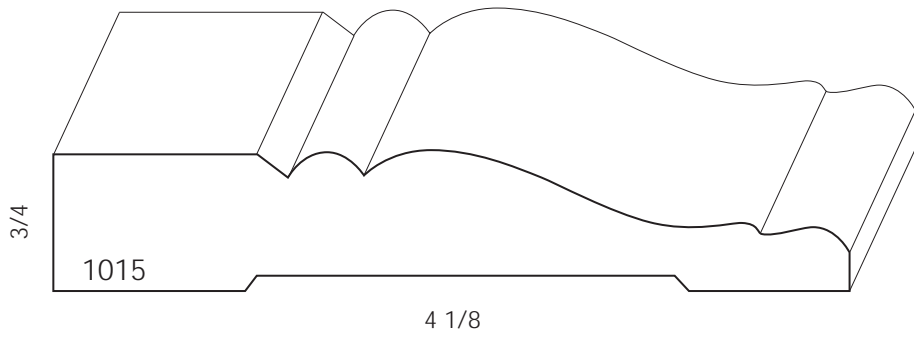
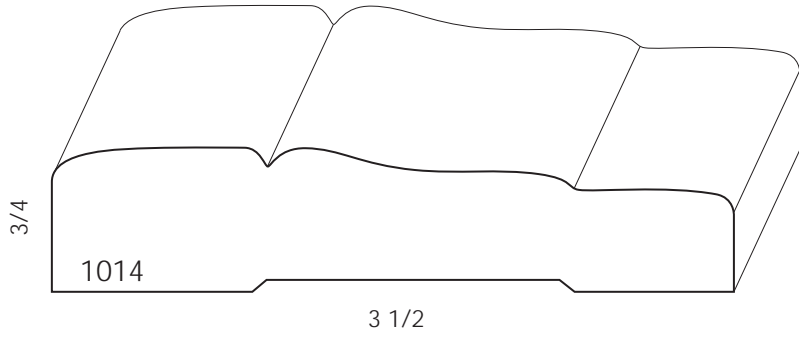
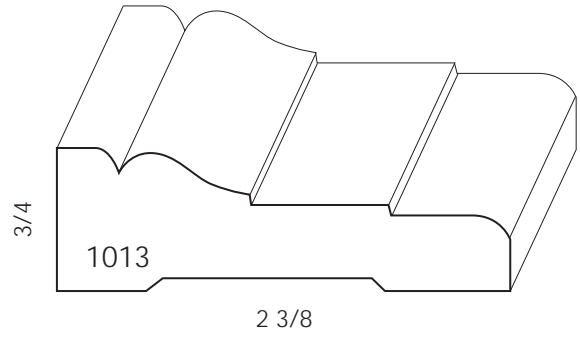
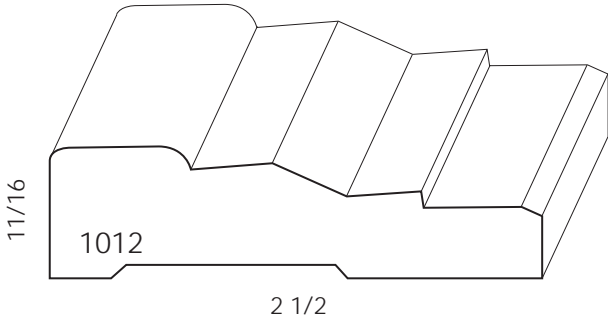
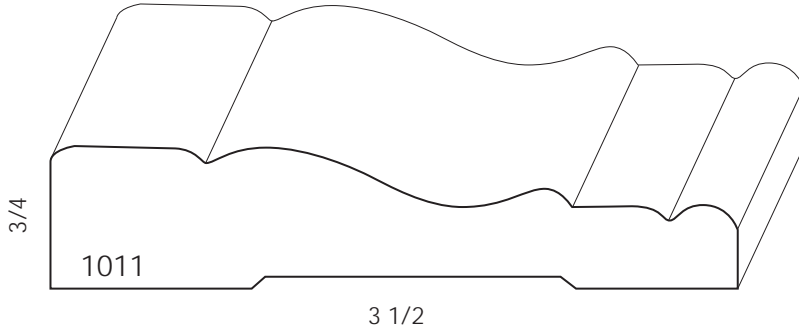
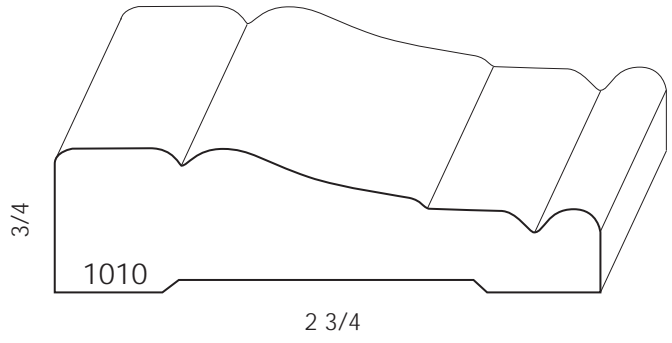
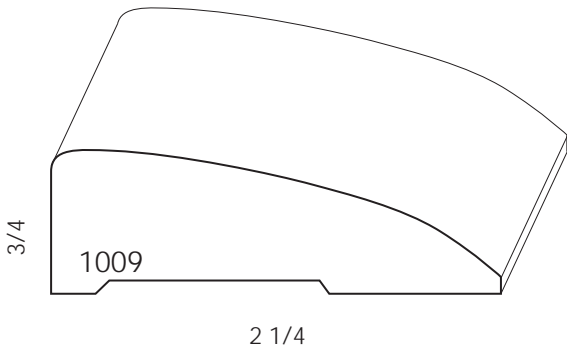

Casing

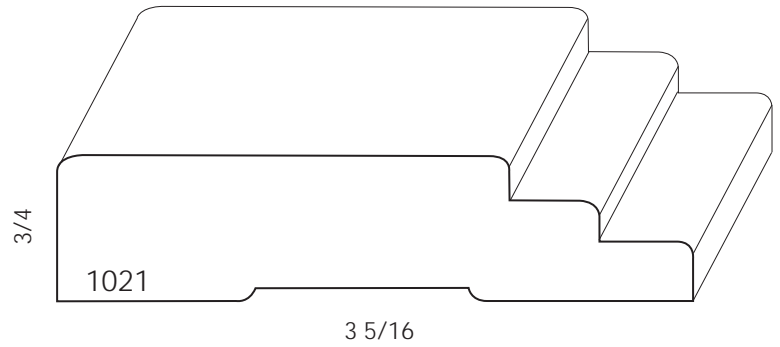
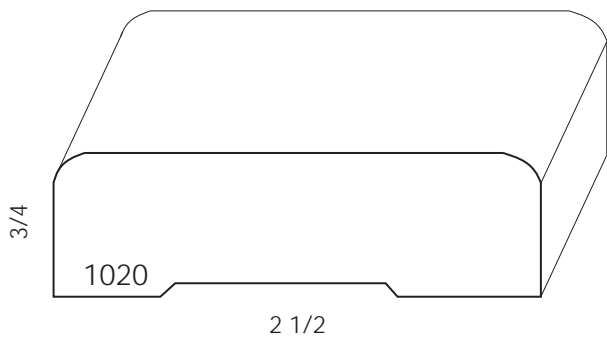
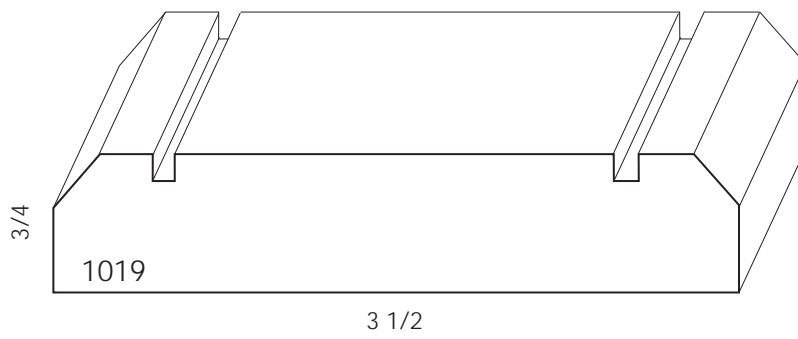
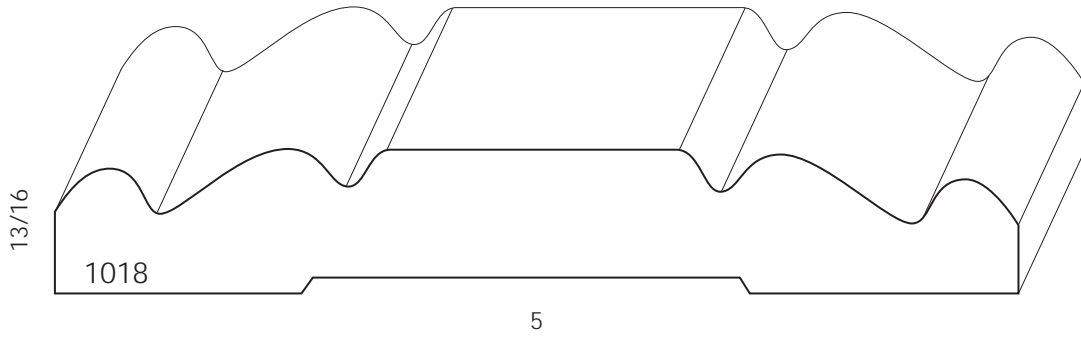
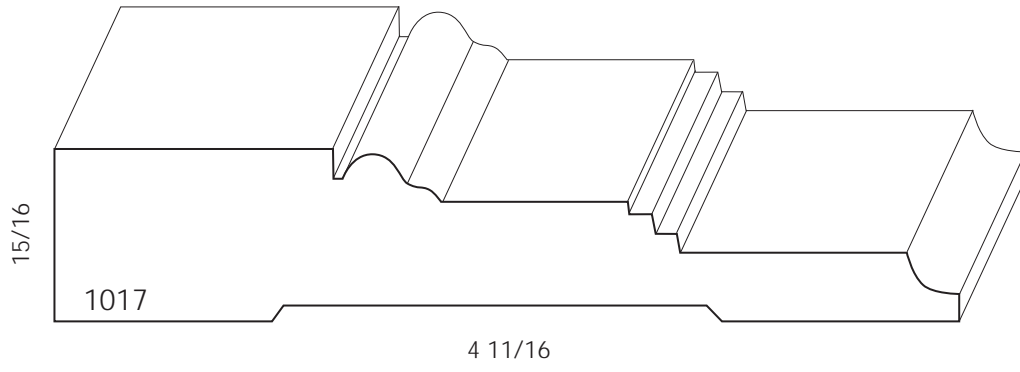
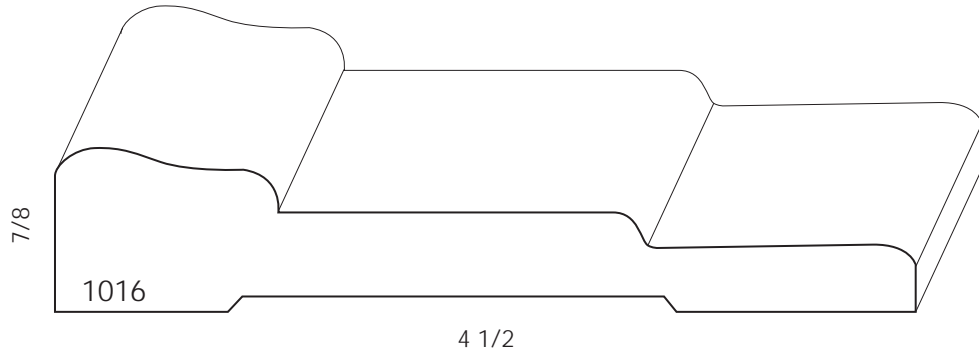

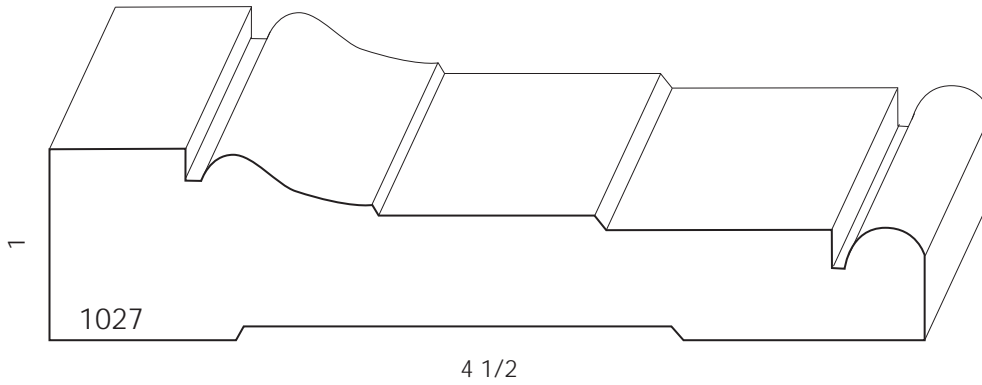
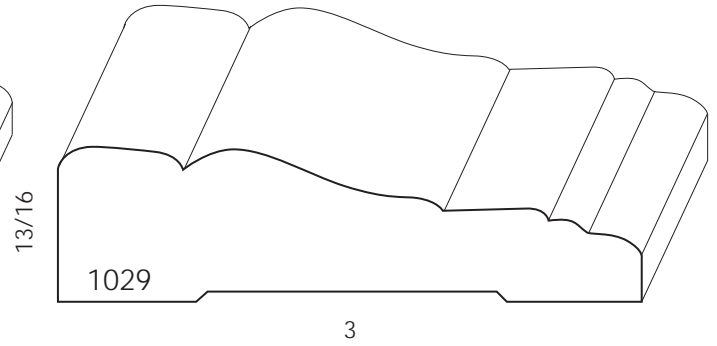
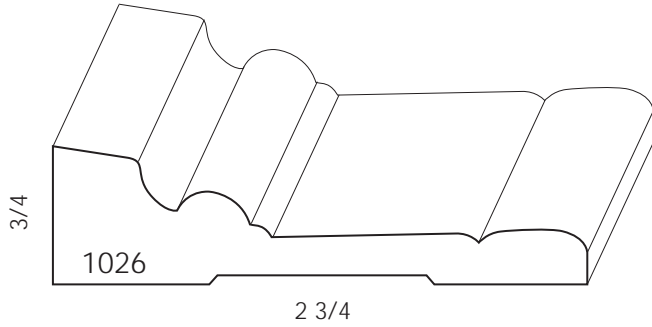
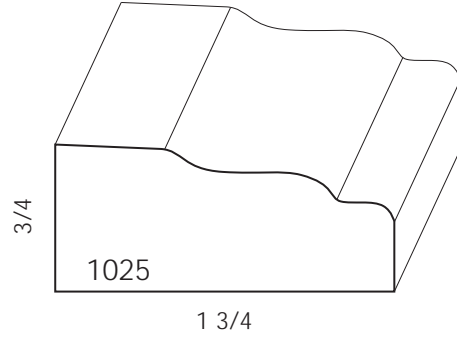
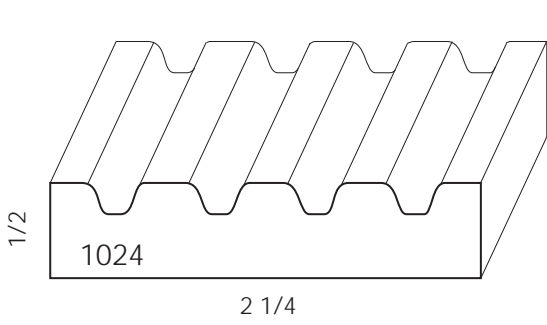
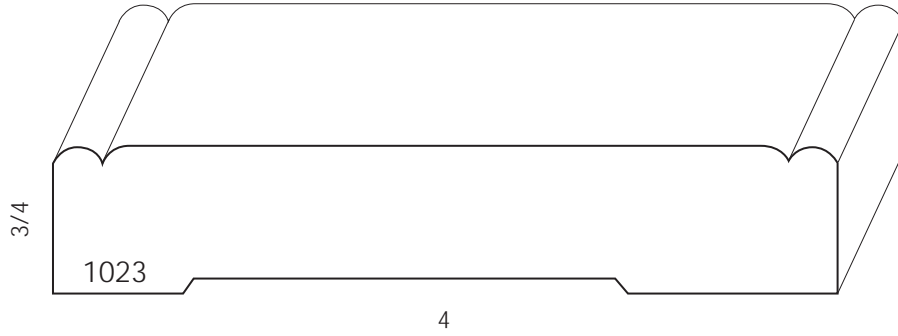
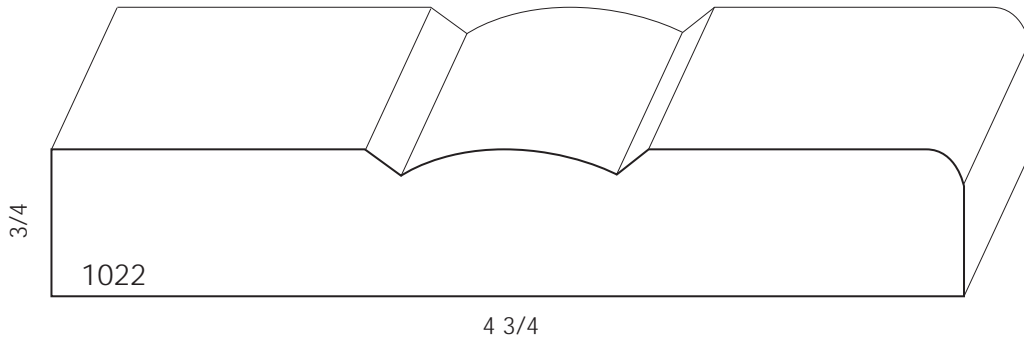

Casing

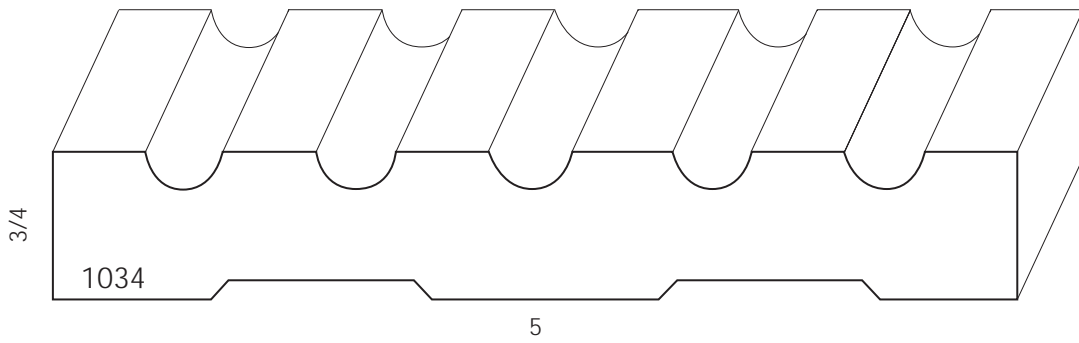
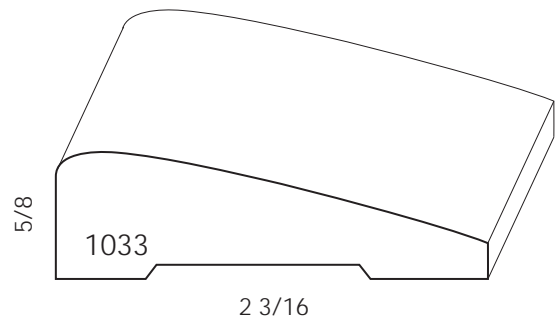
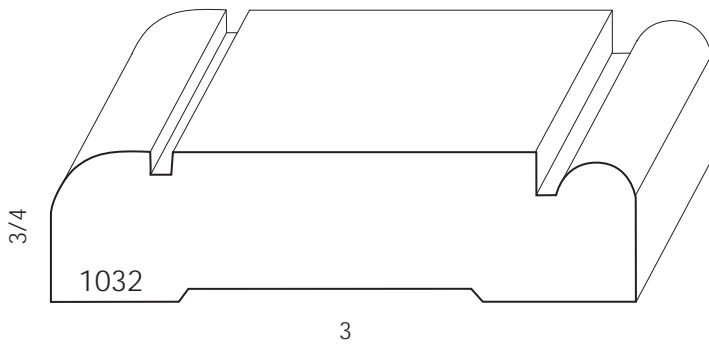
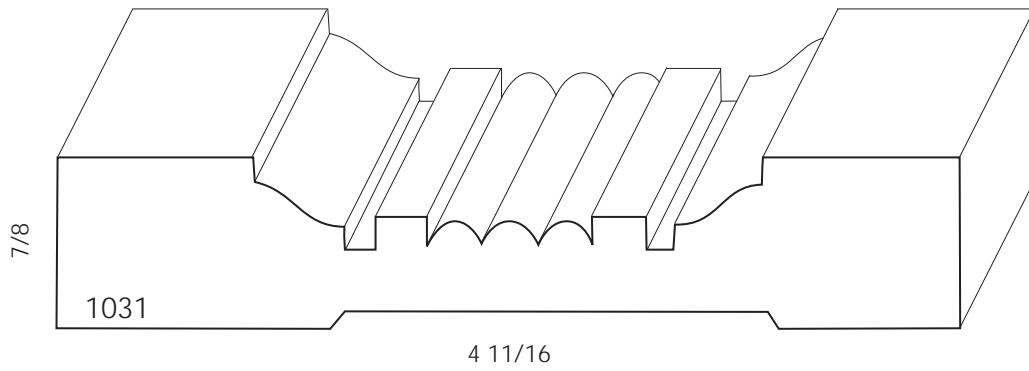
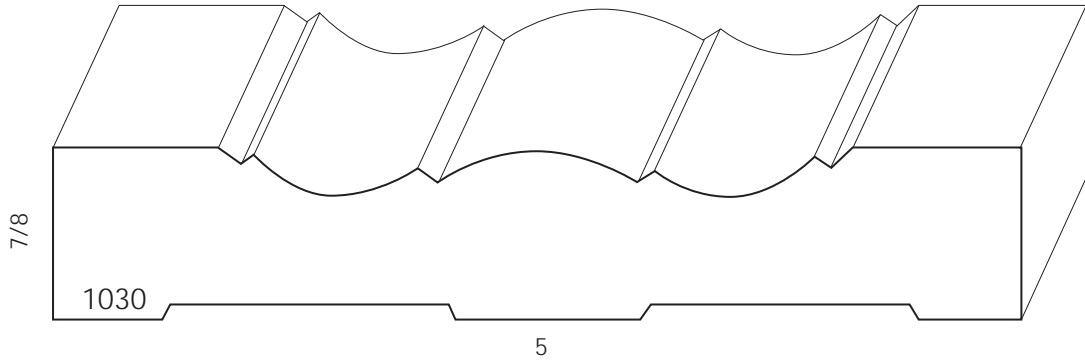
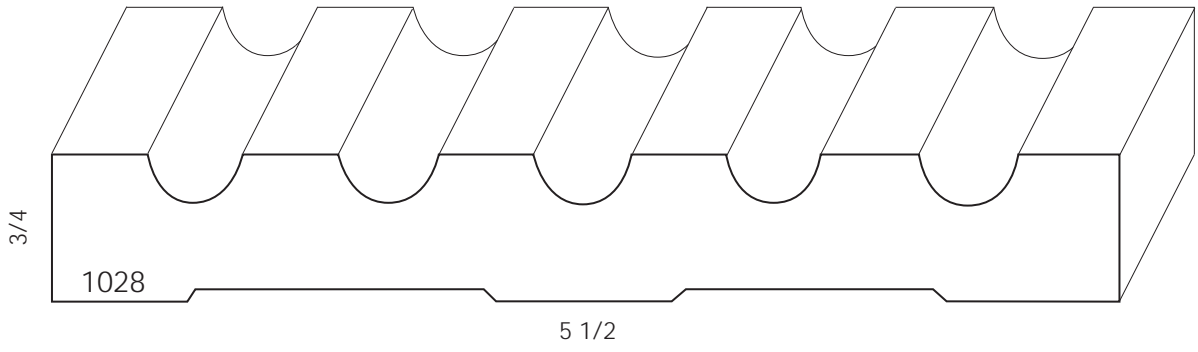

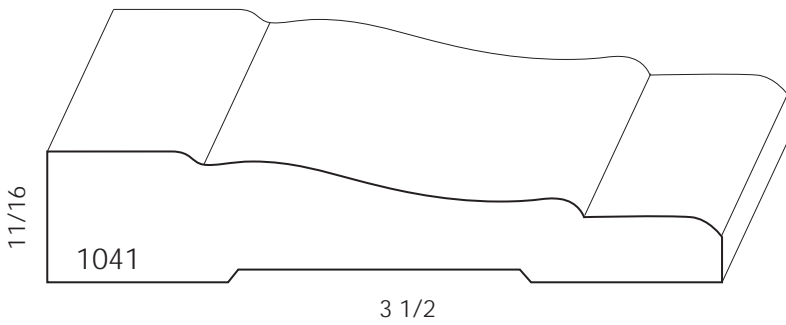
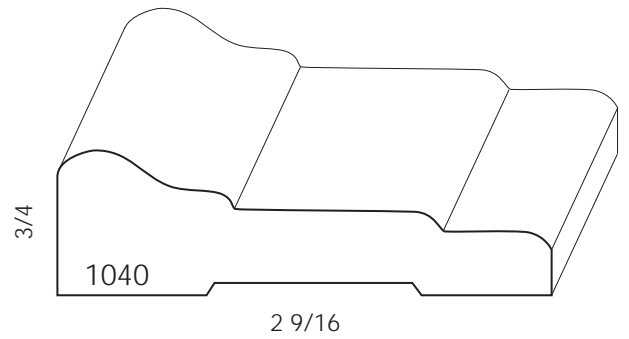
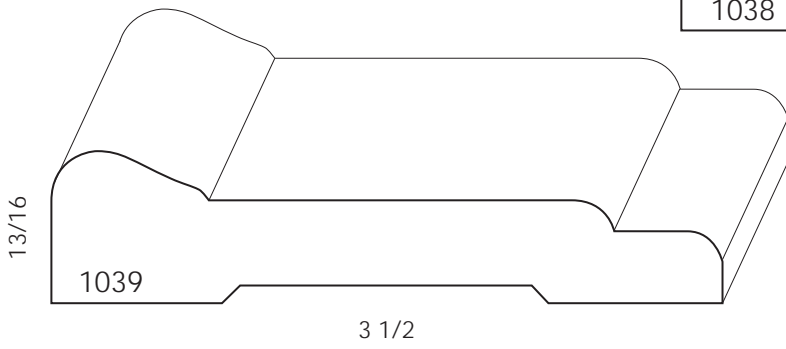
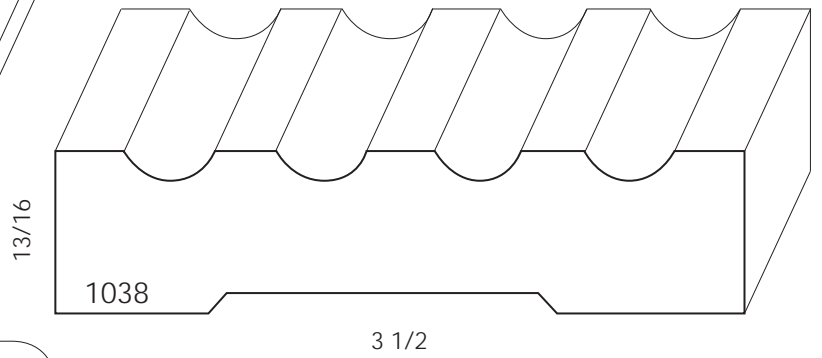
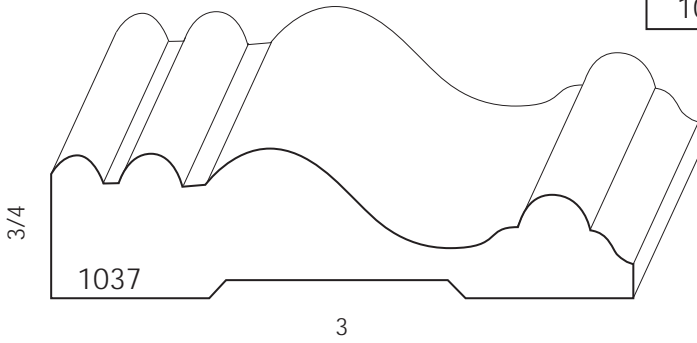
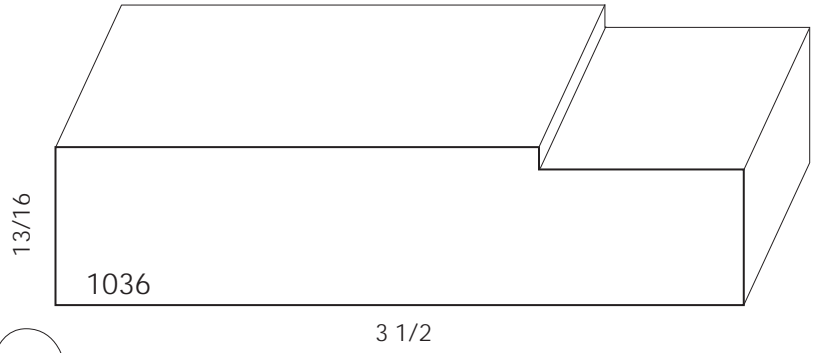
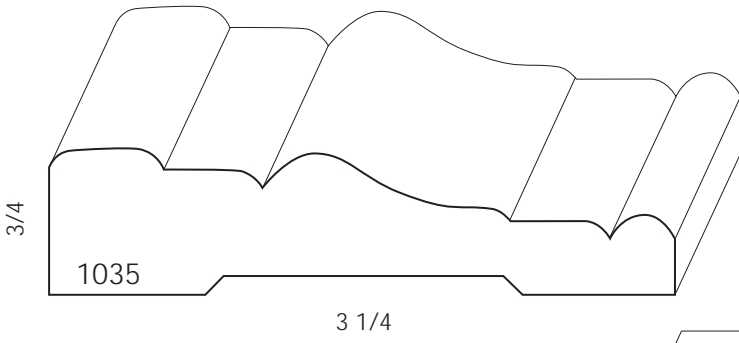

Casing

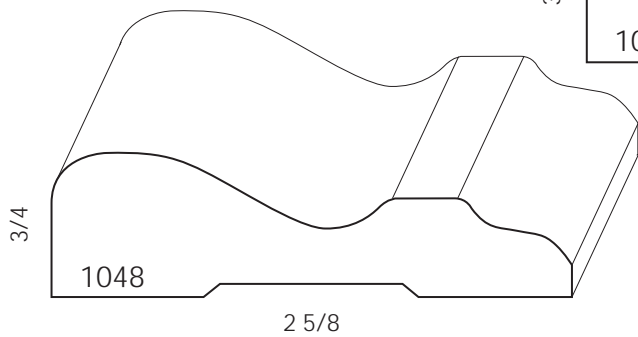
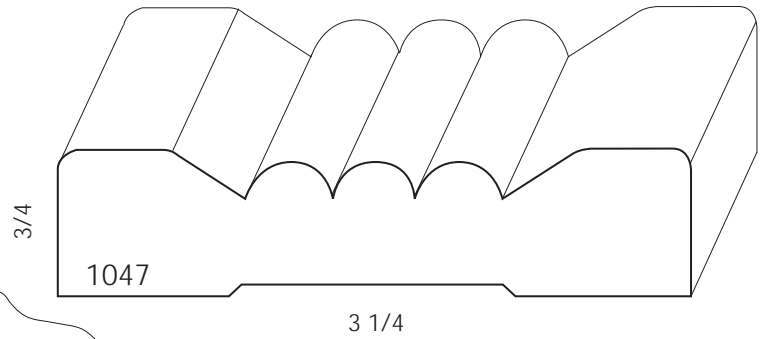
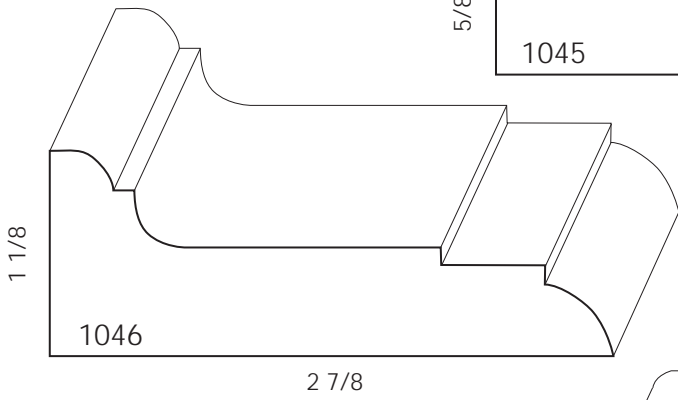
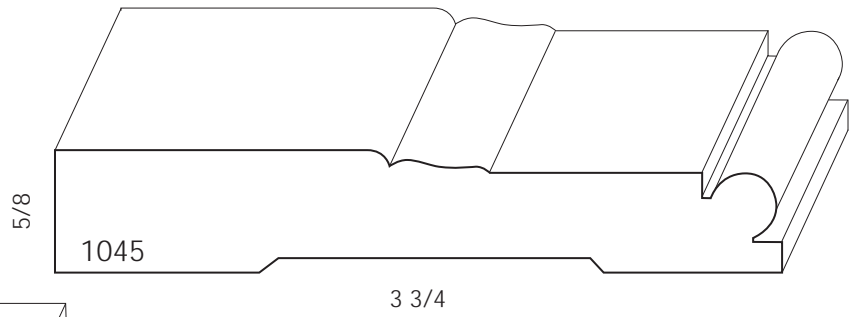
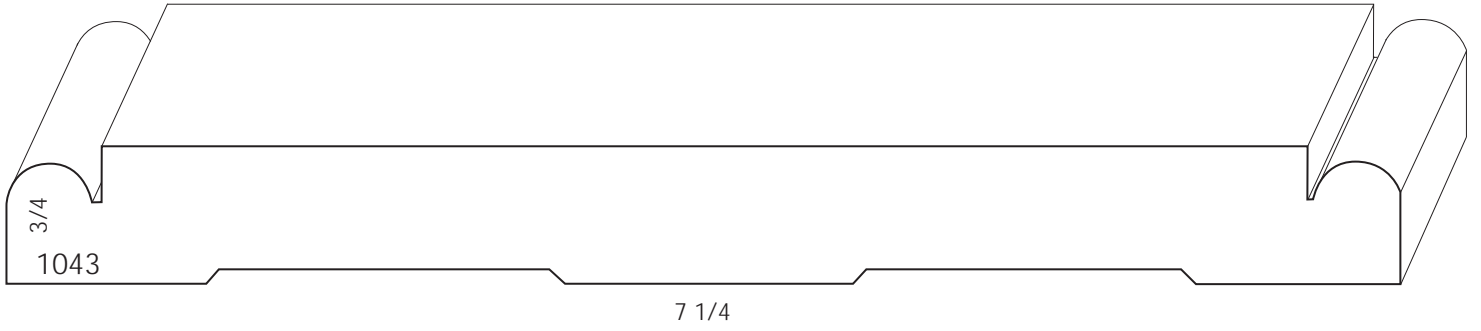
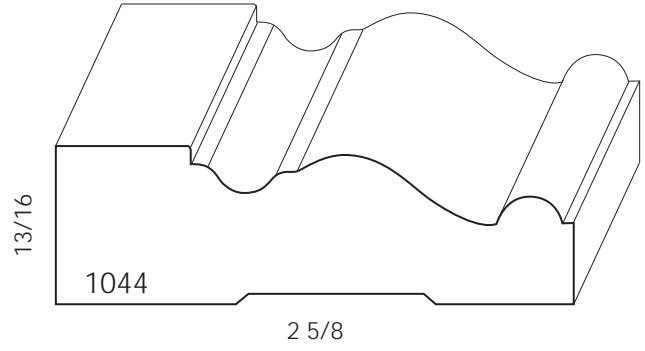
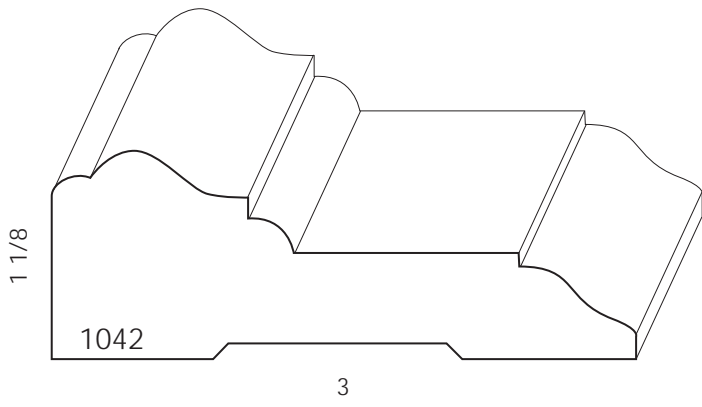

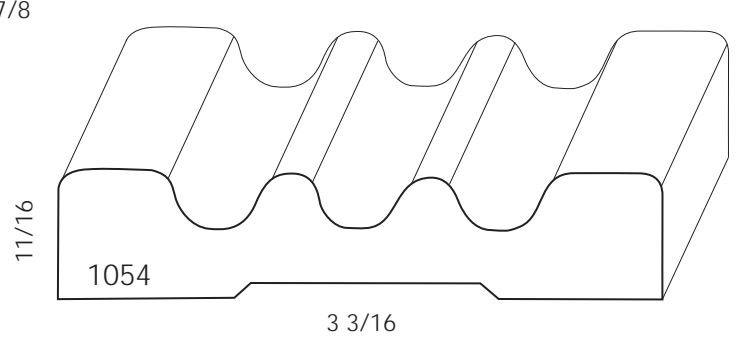
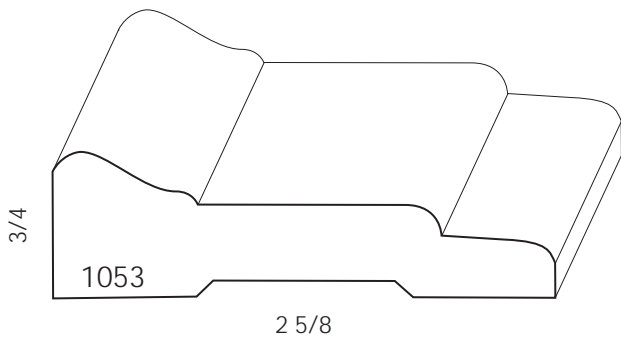
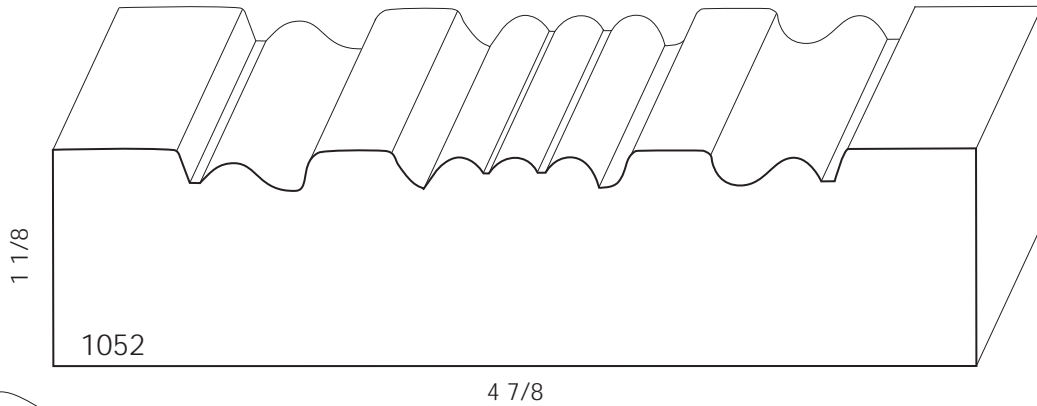
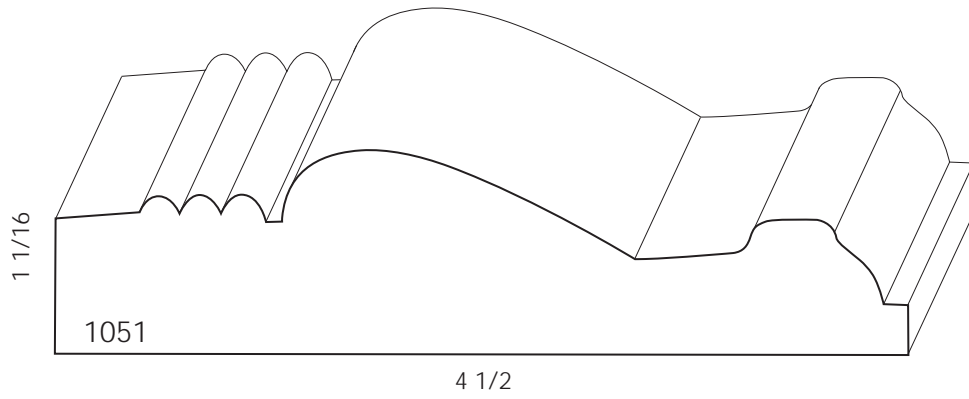
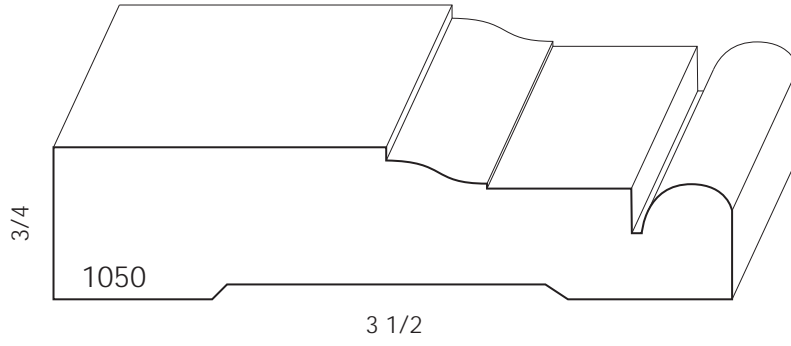
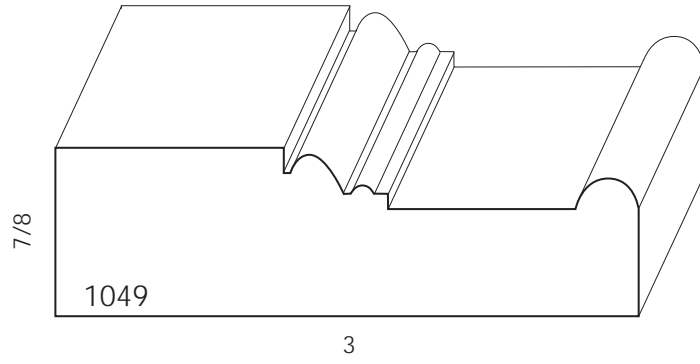

Casing

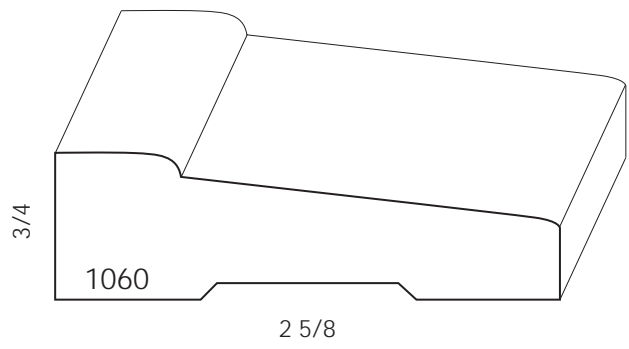
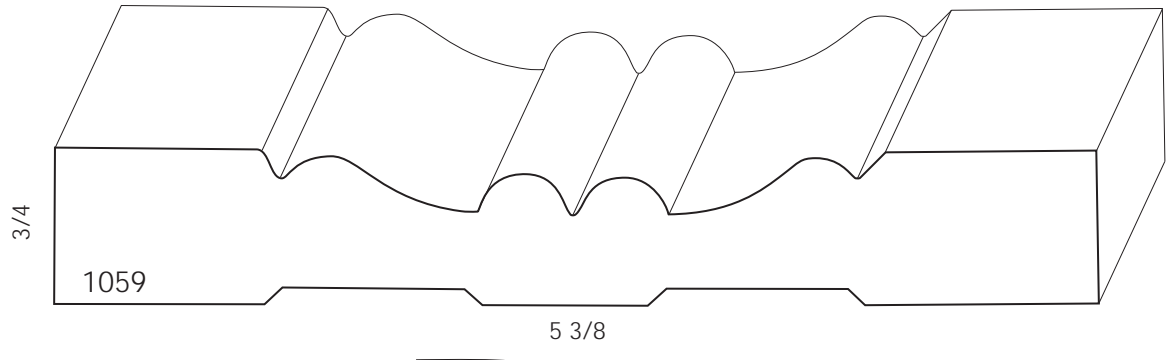
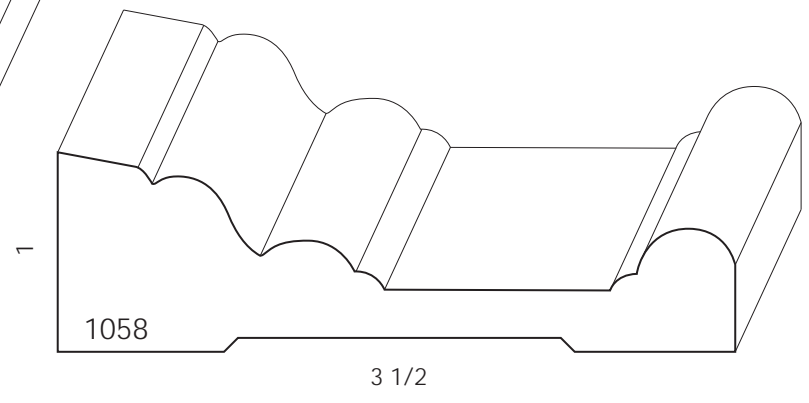
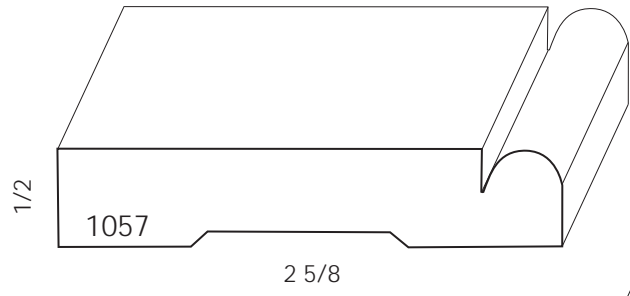
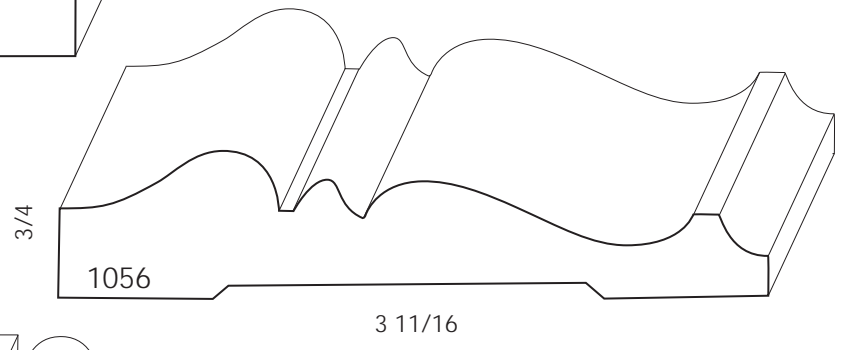
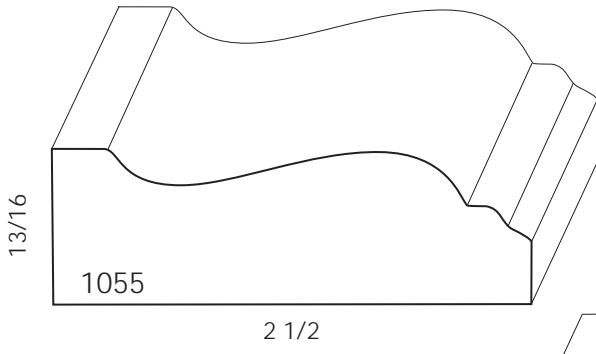

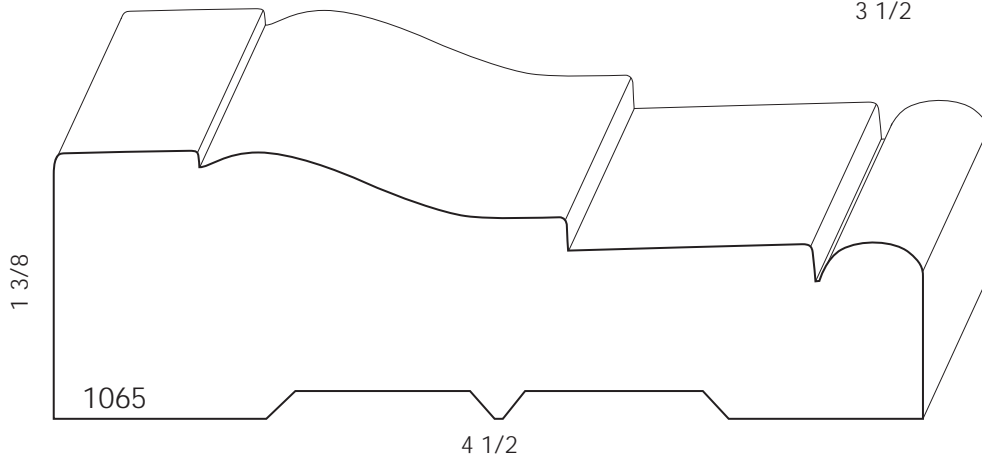
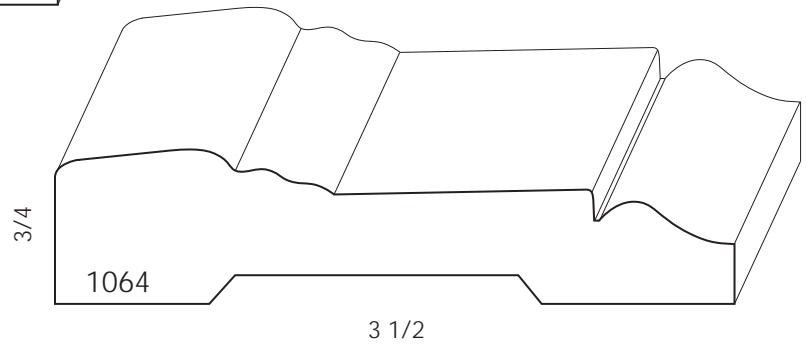
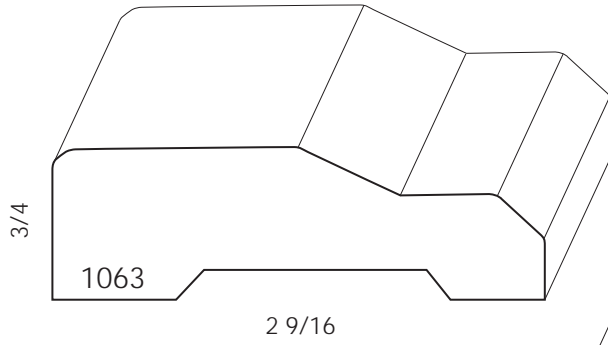
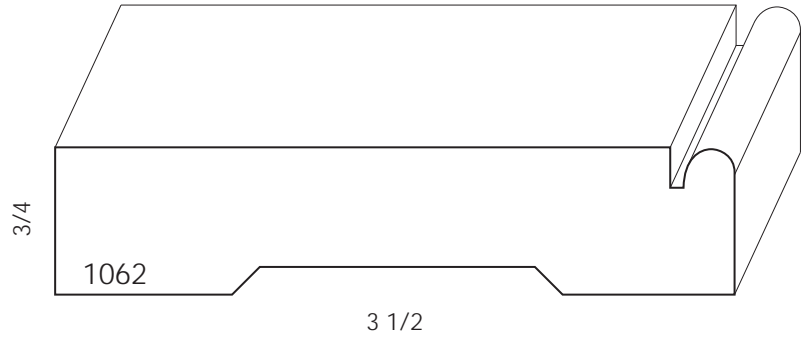
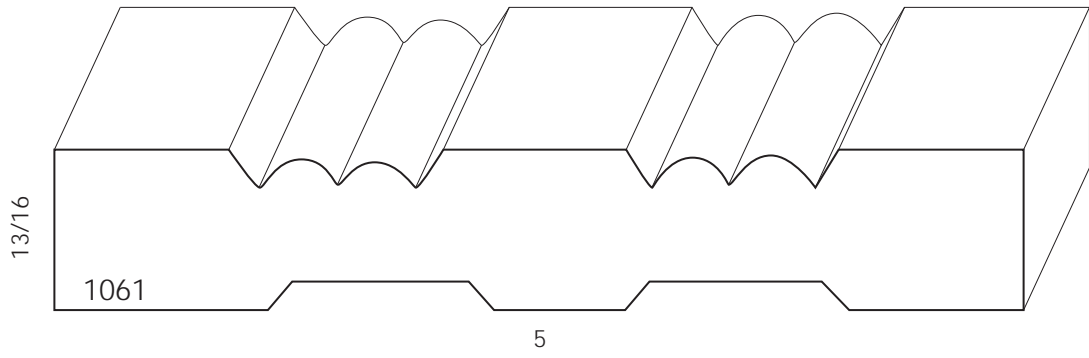

Casing

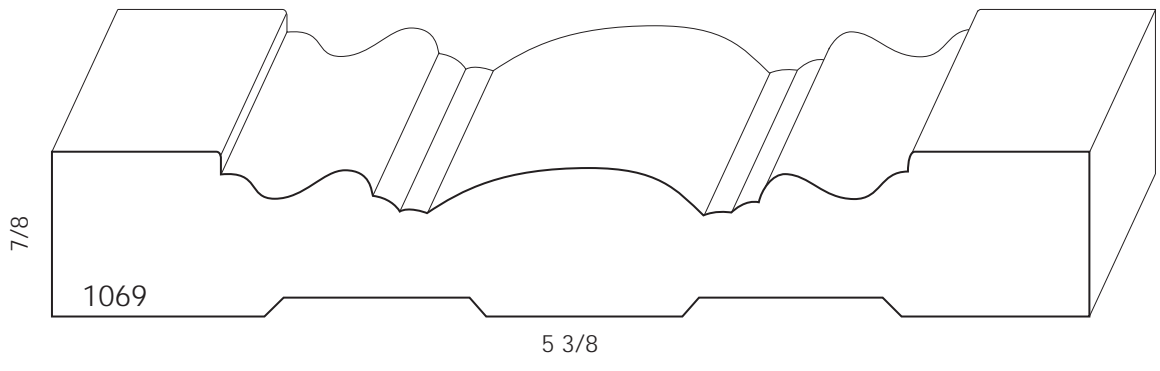
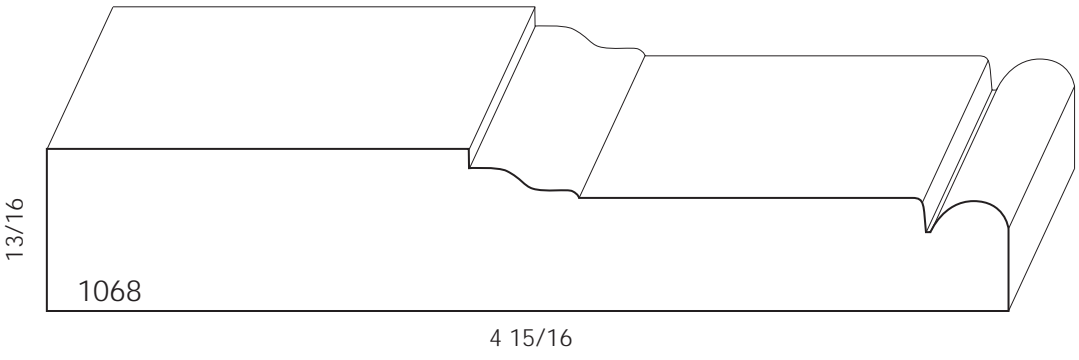
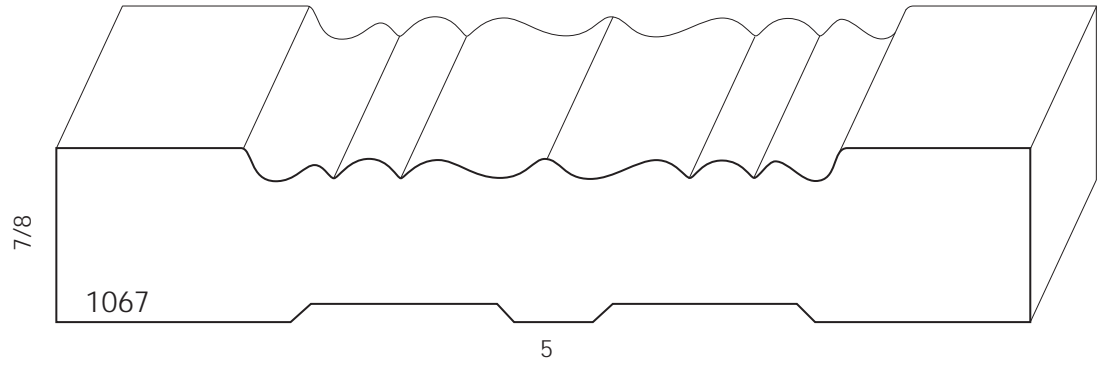
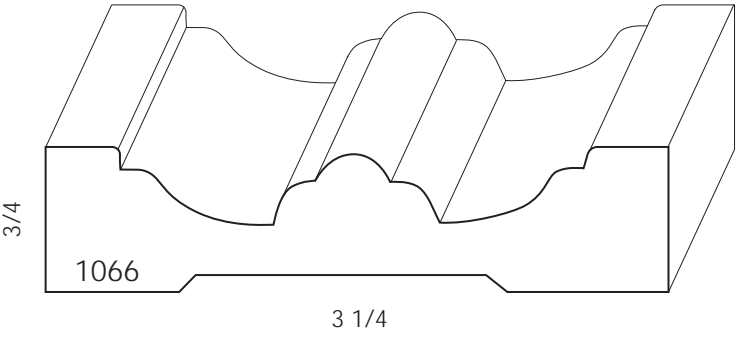

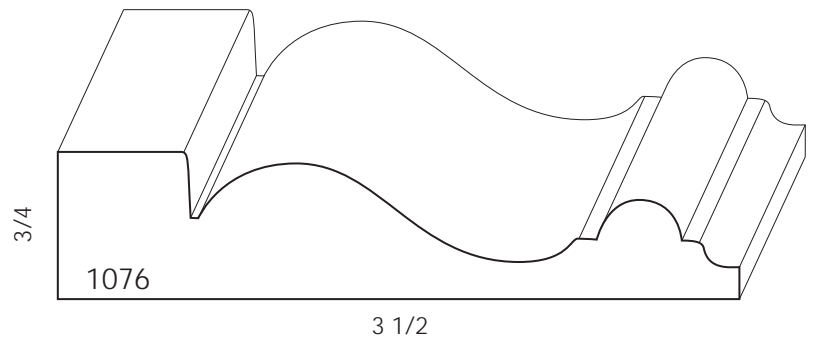
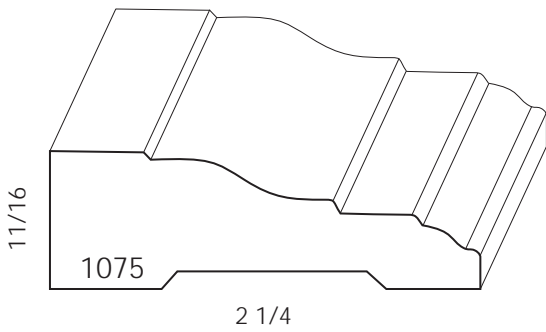
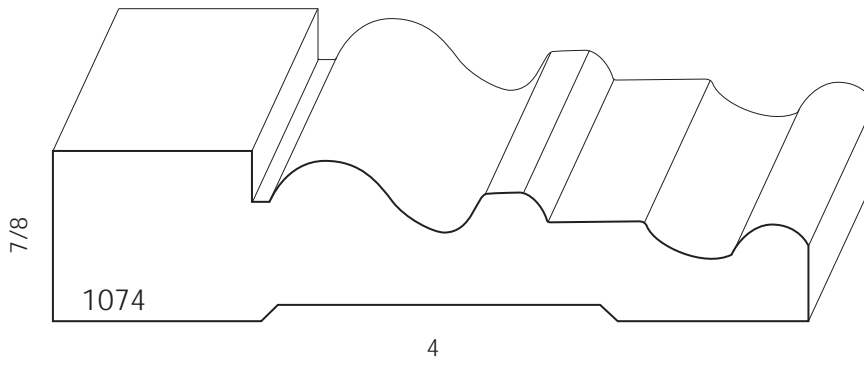
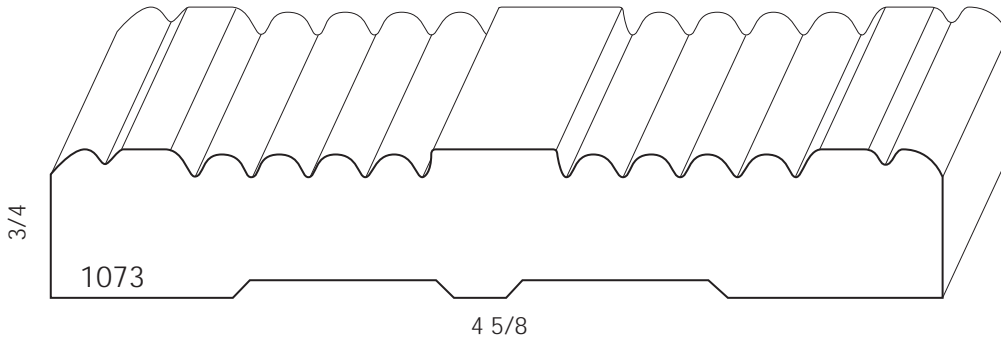
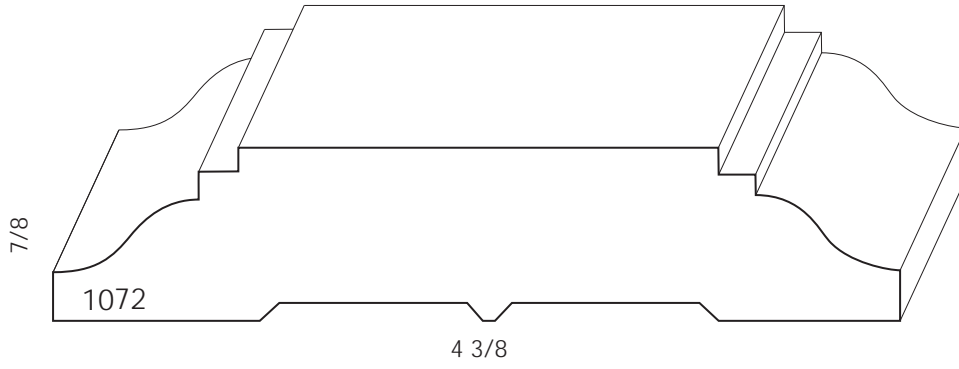
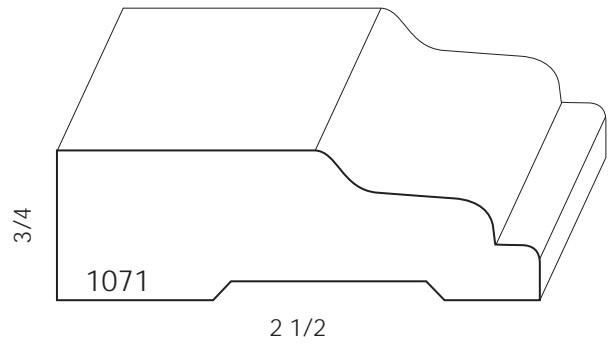
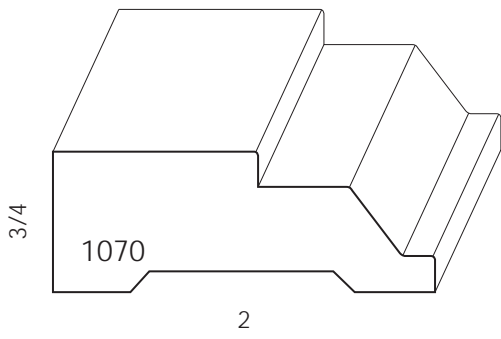

Casing

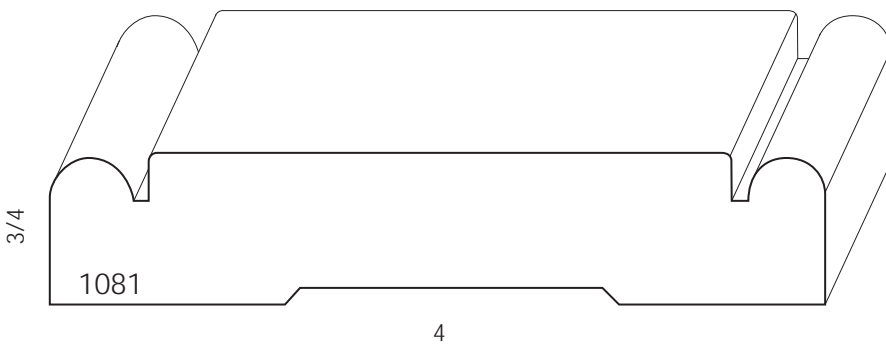
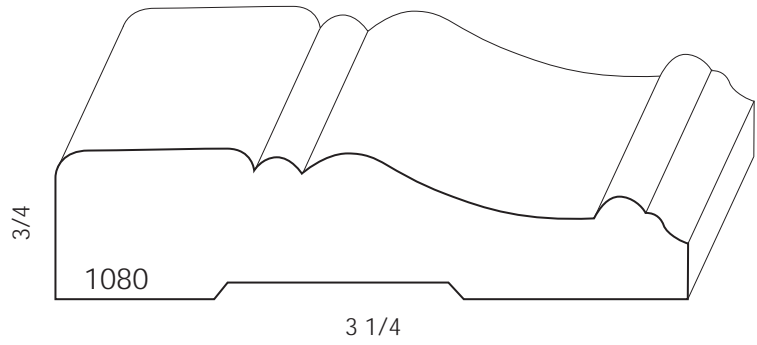
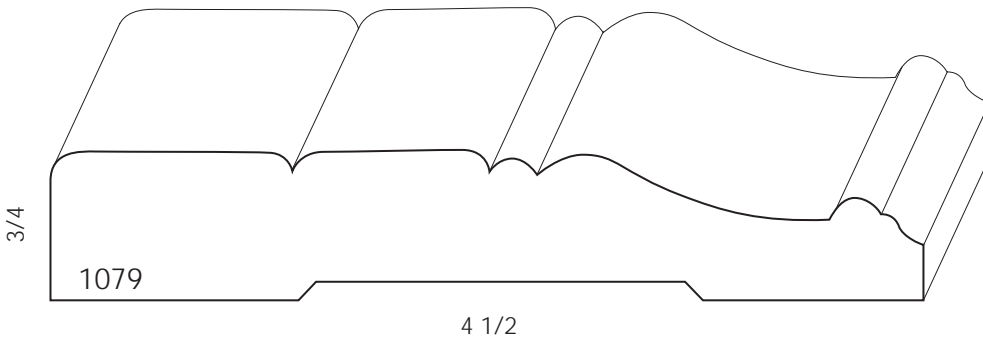
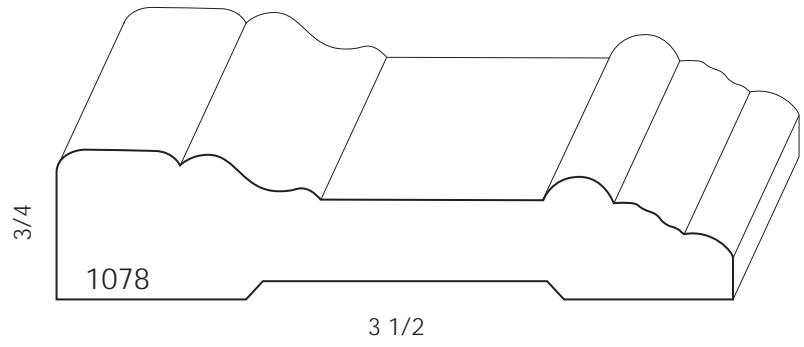
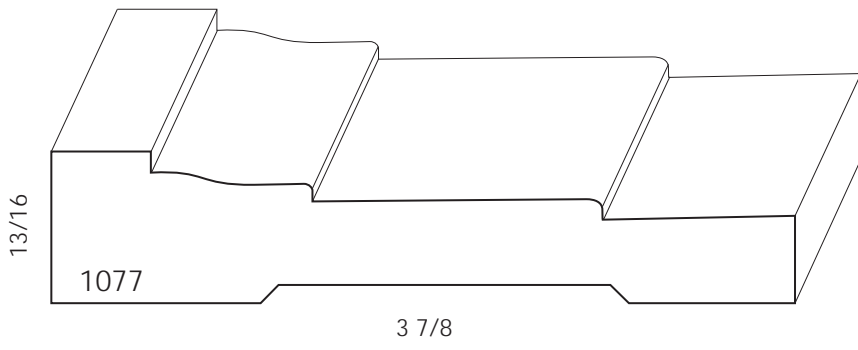

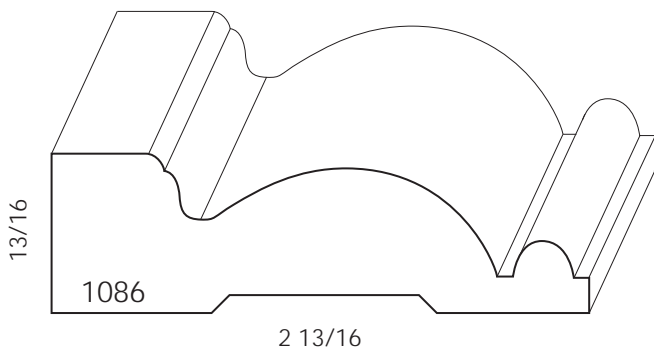
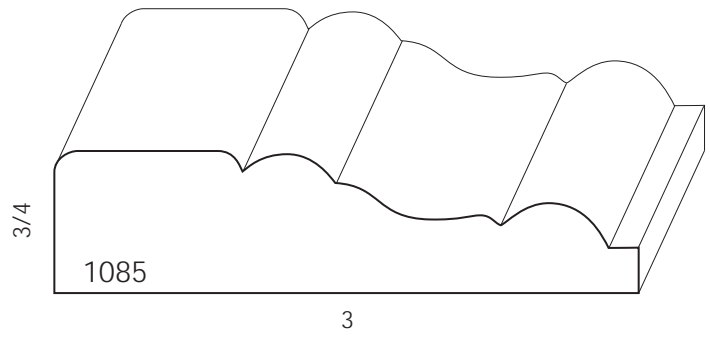
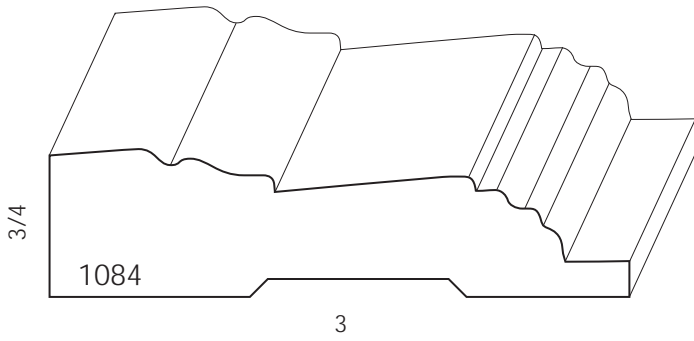
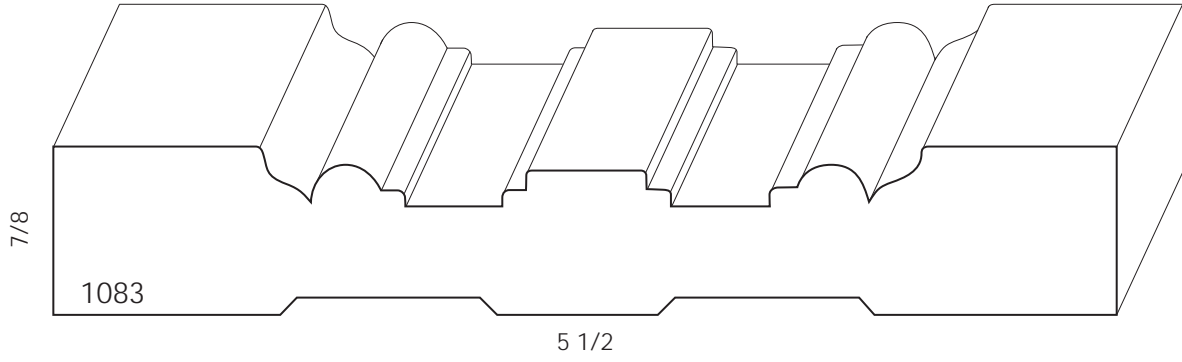
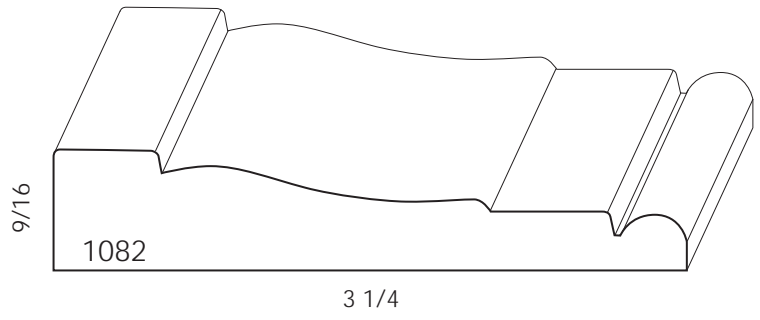

Casing

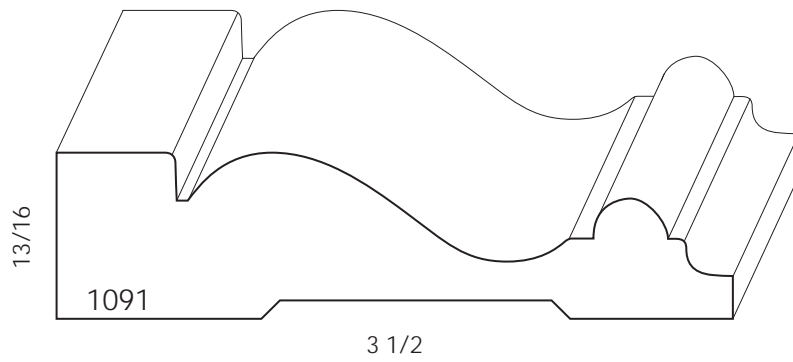
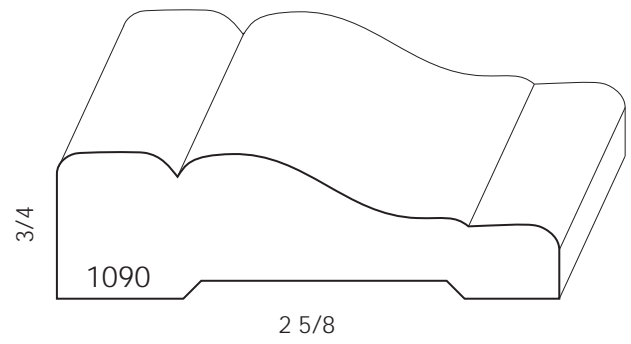
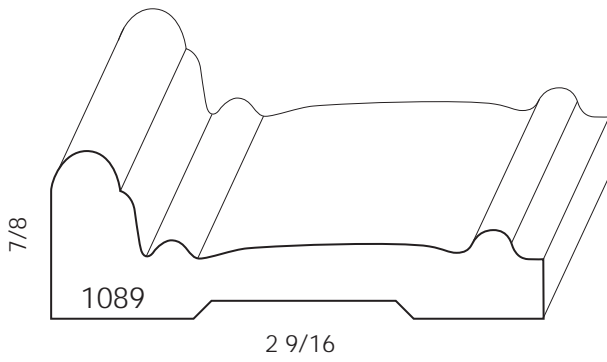
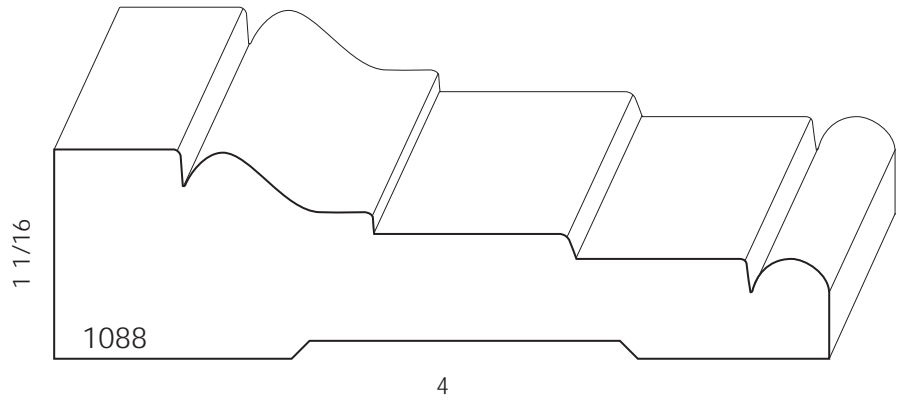
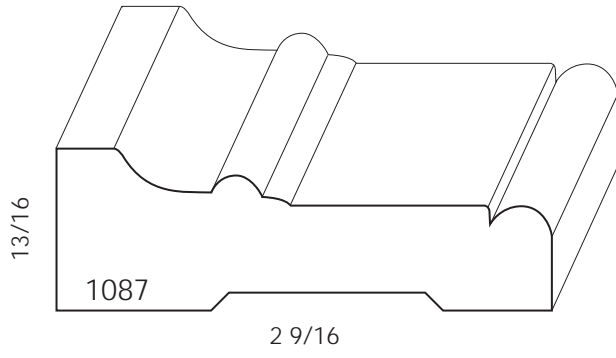

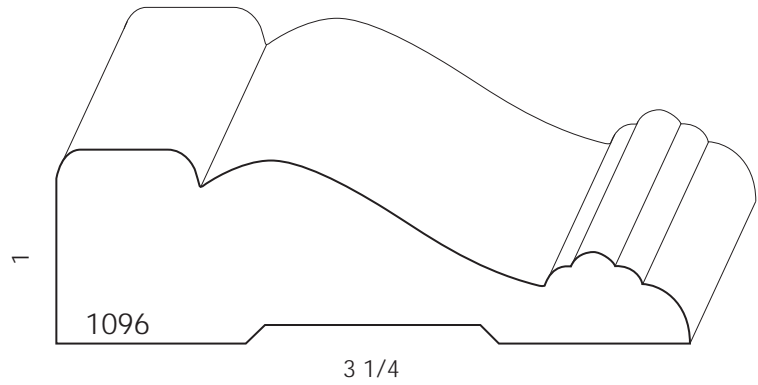
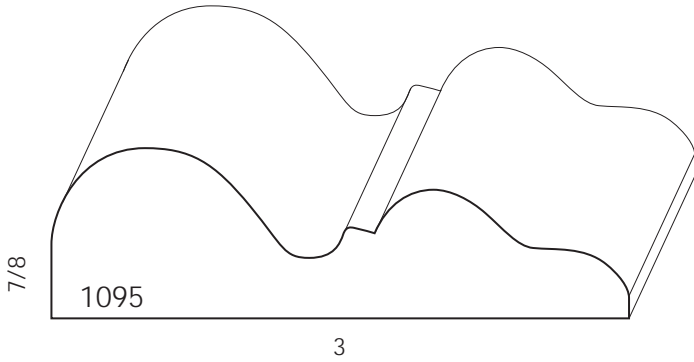
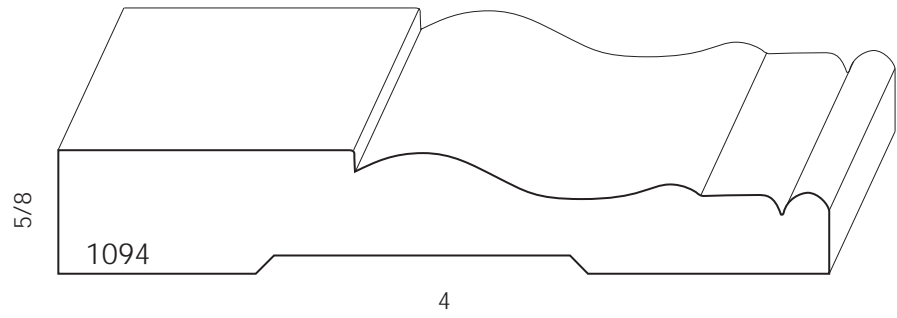
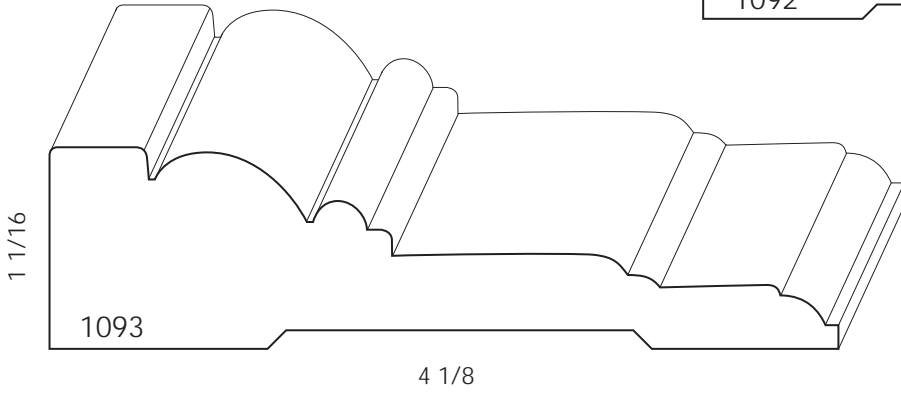
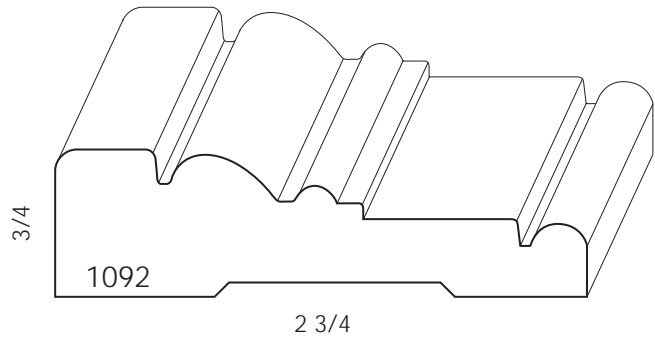

Casing

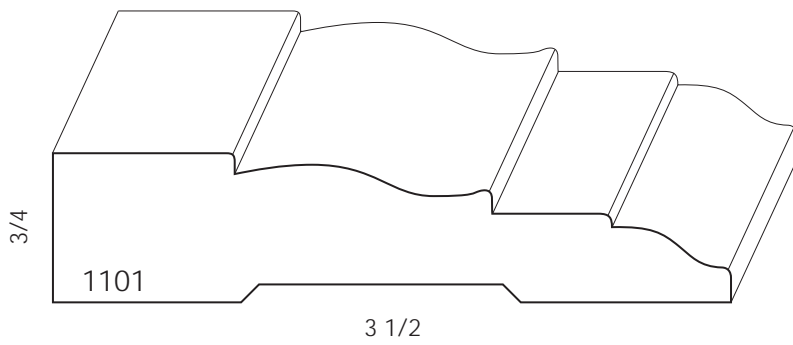
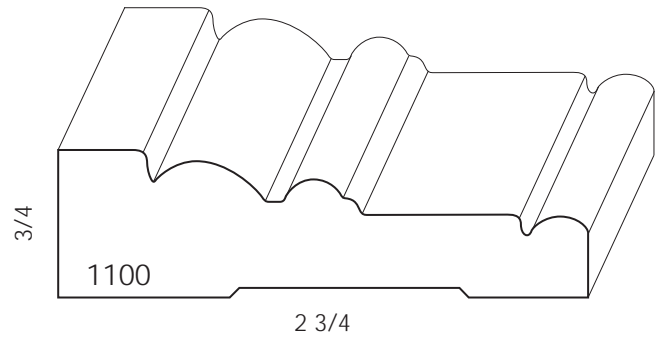
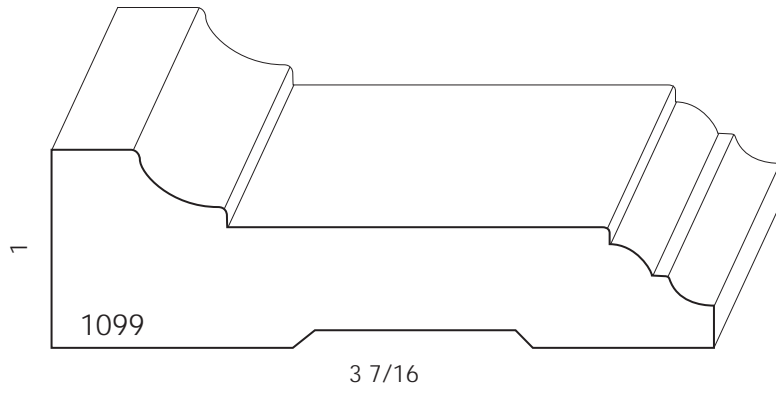
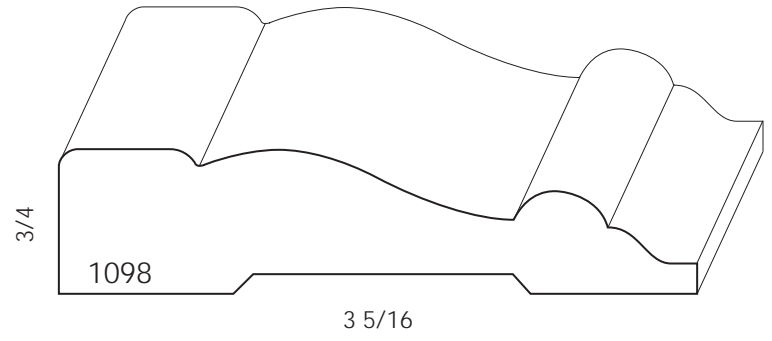
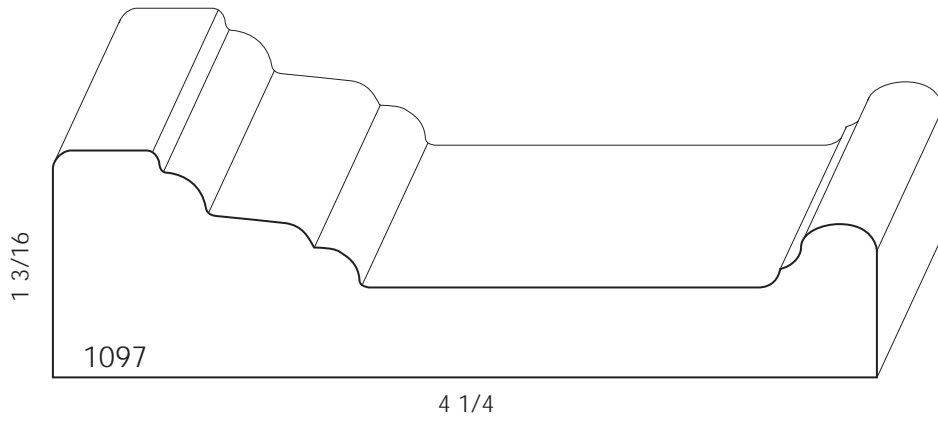

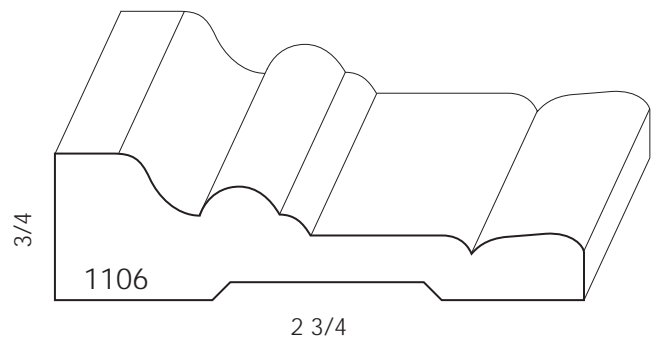
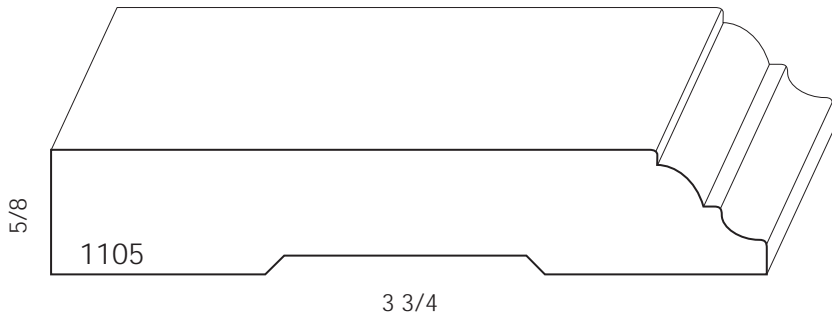
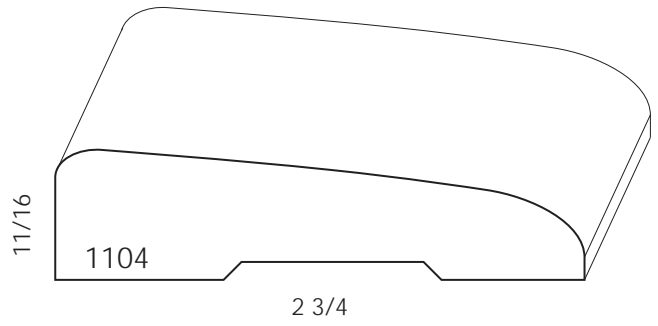
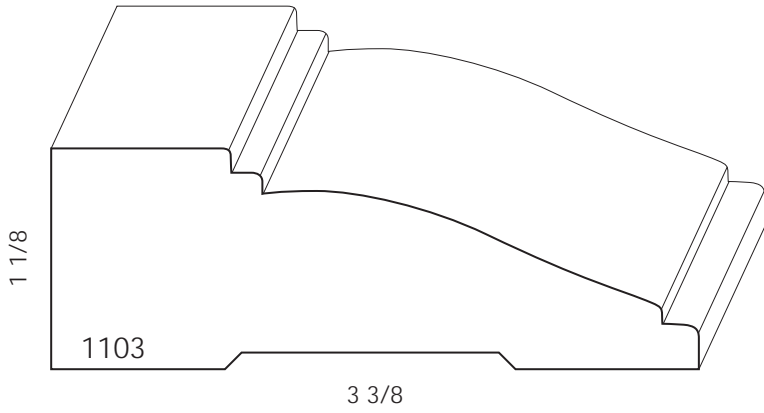
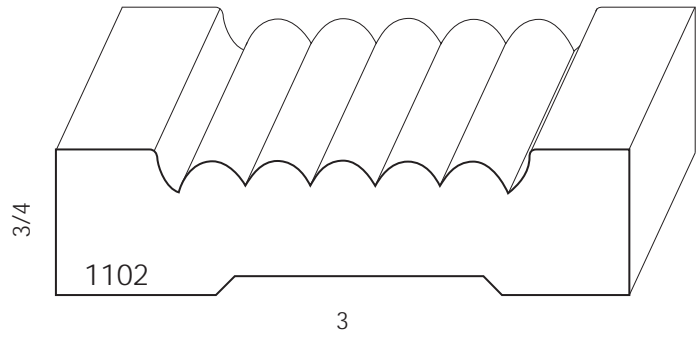

Casing

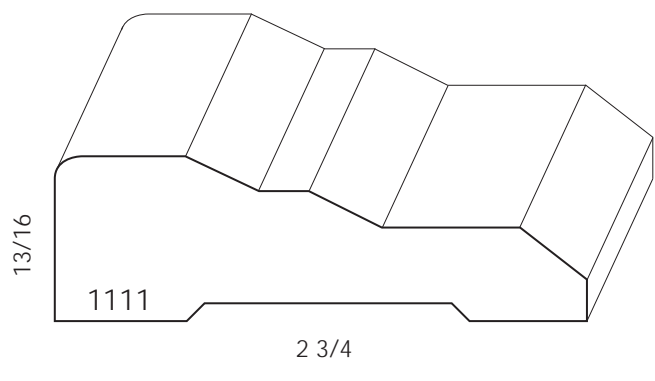
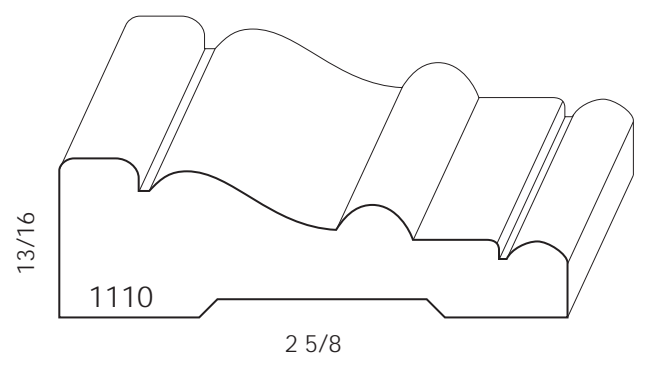
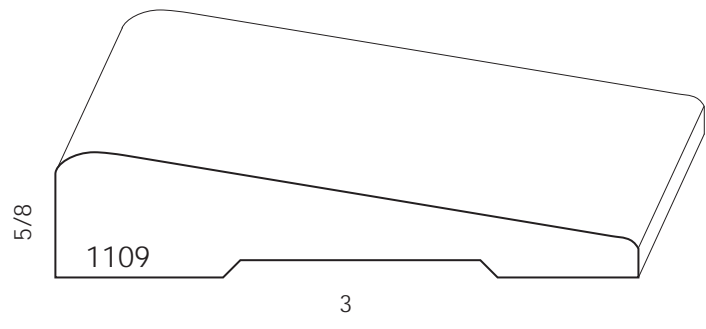
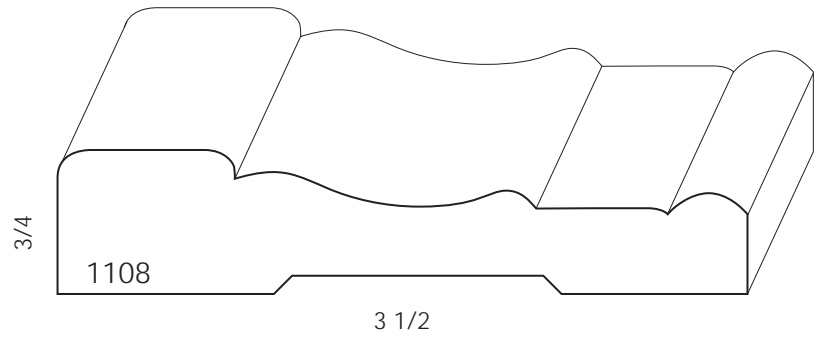
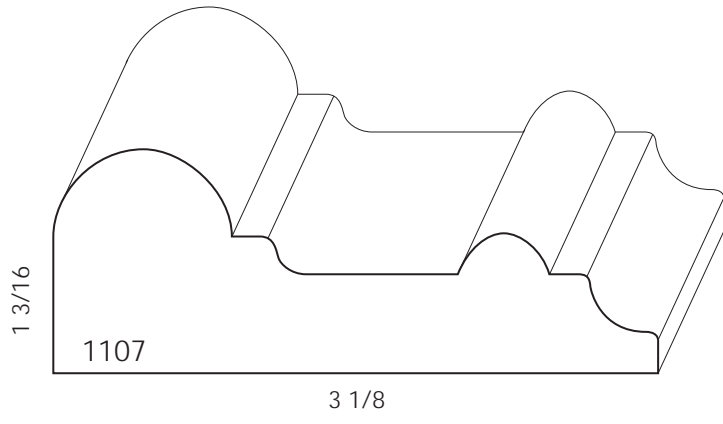

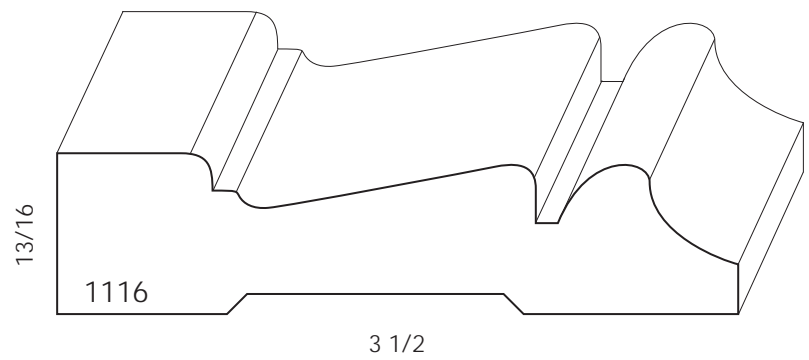
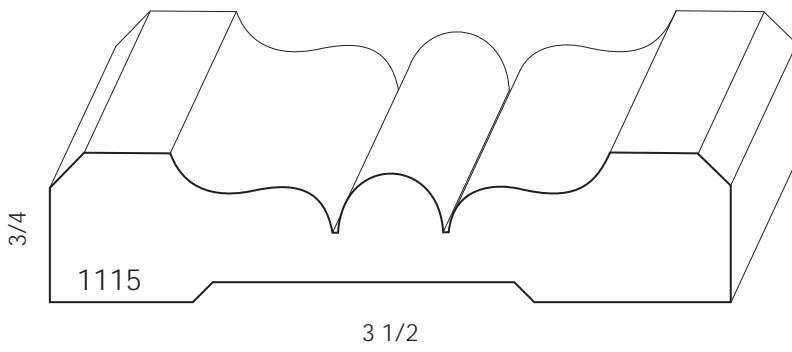
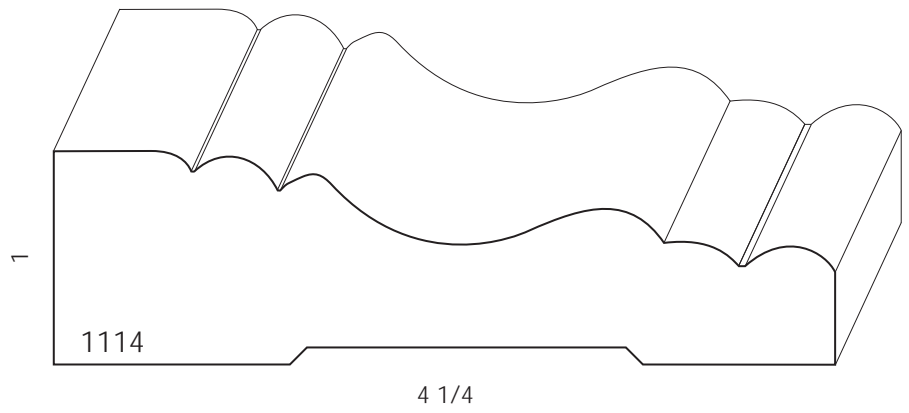
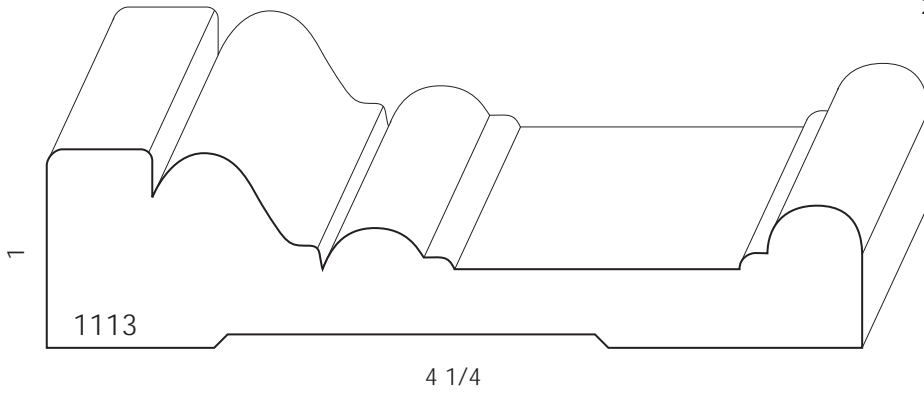
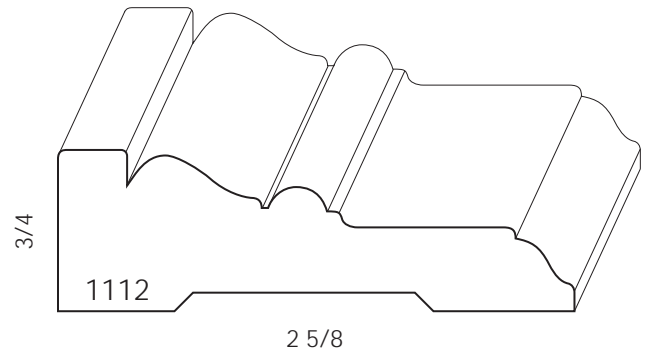

Casing

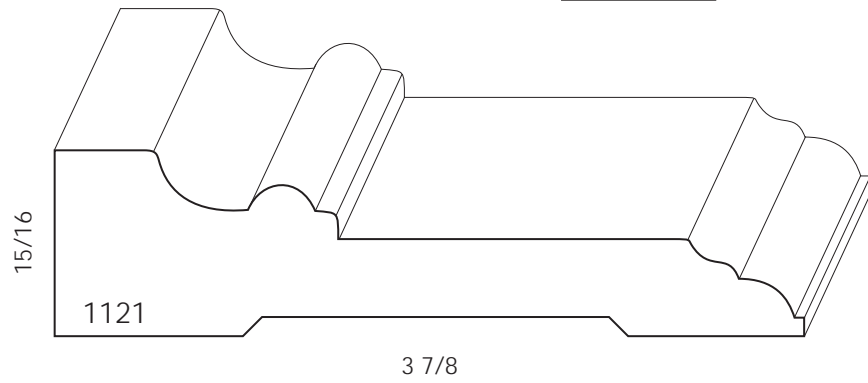
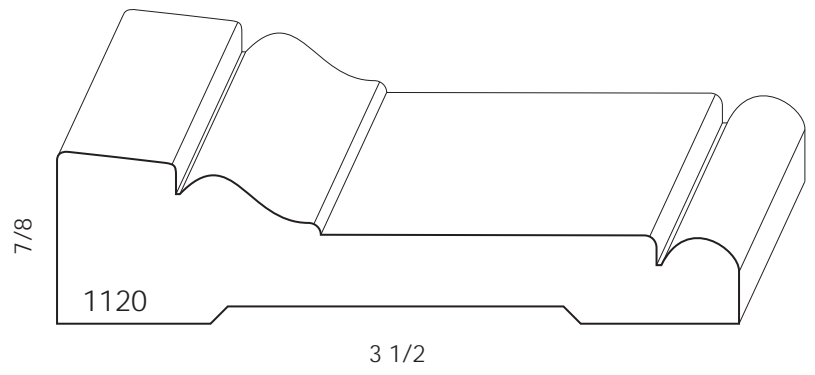
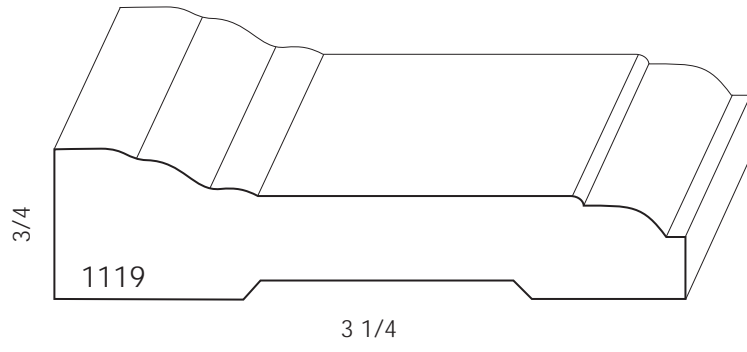
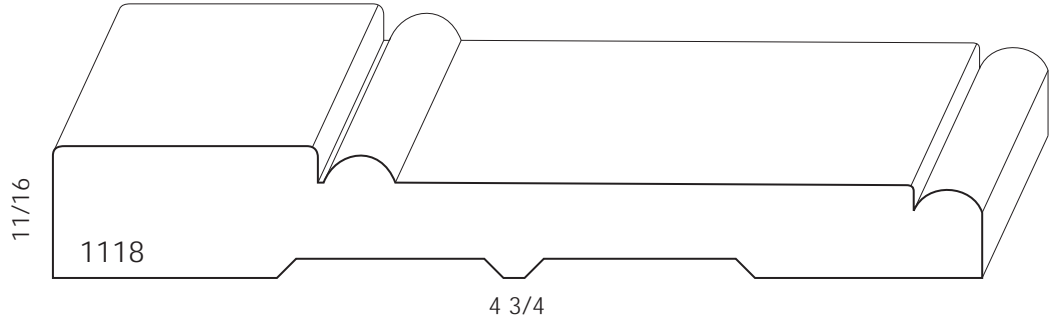
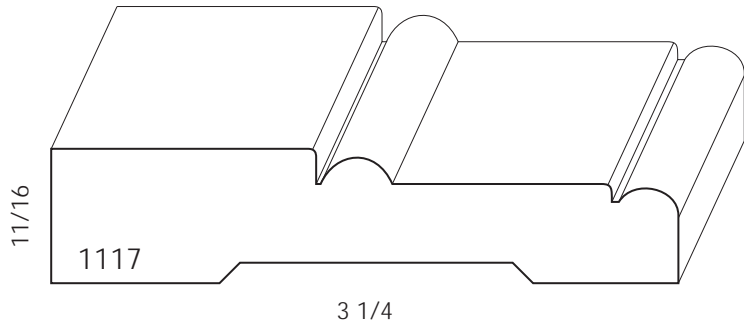

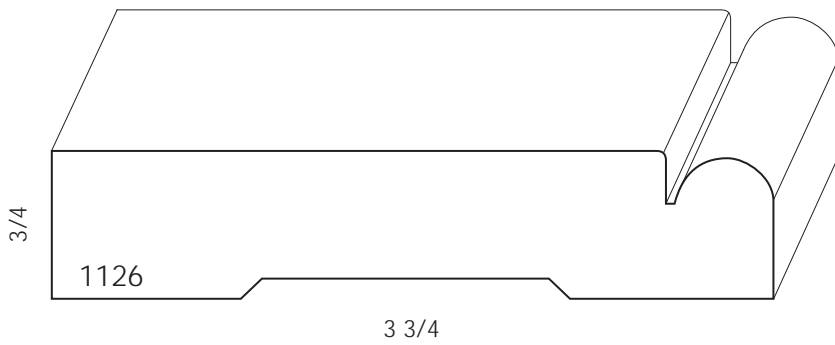
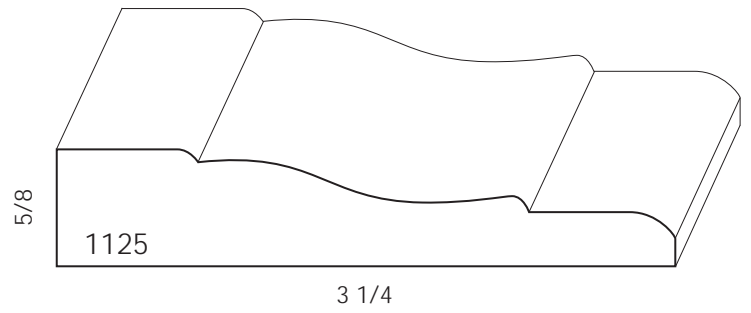
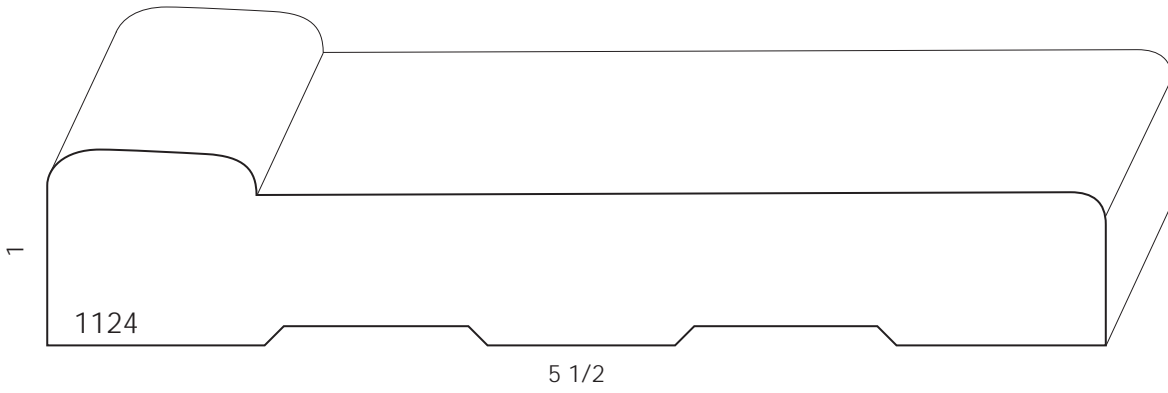
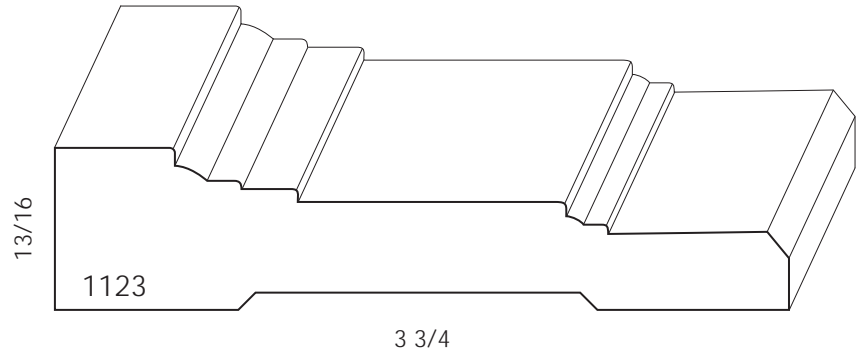
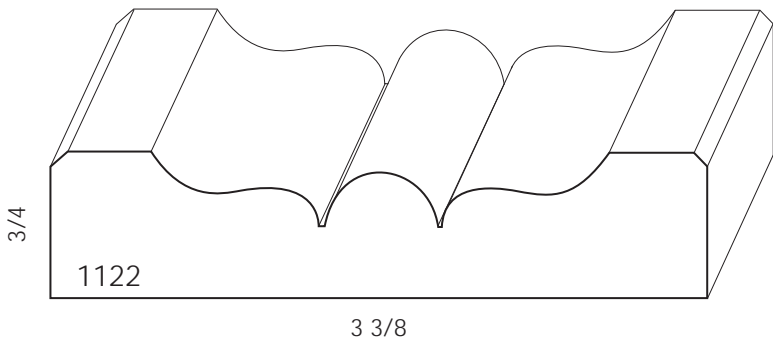

Casing

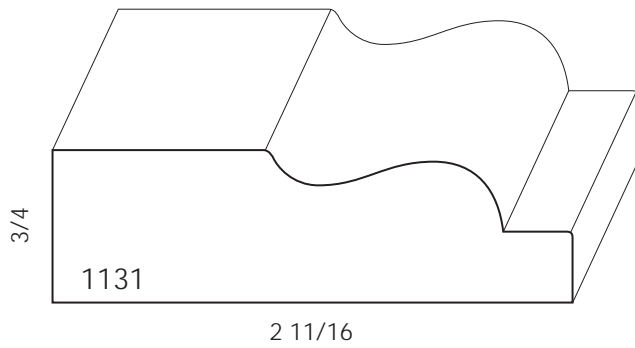
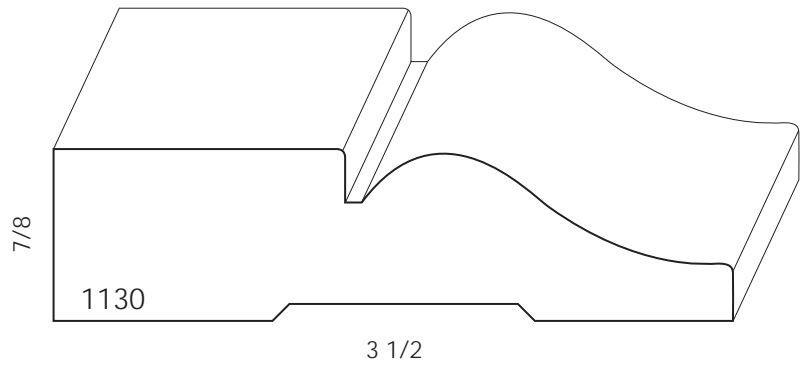
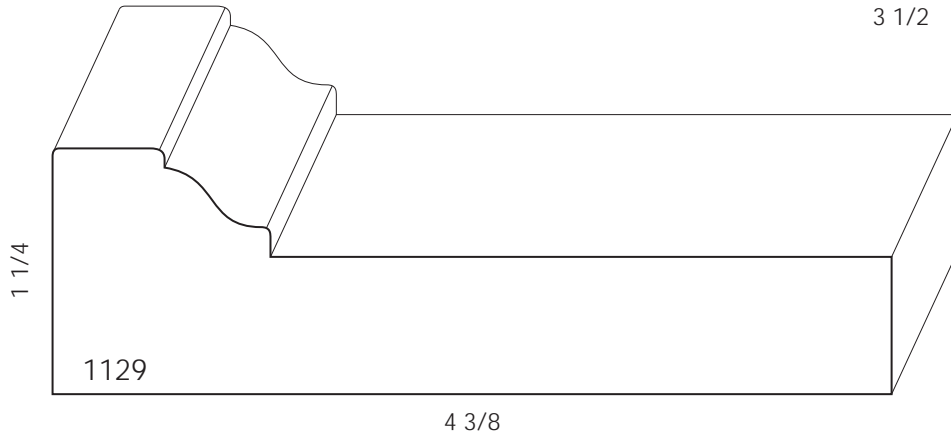
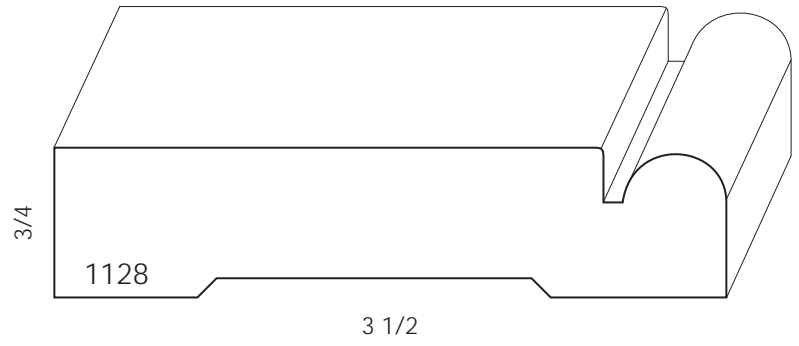
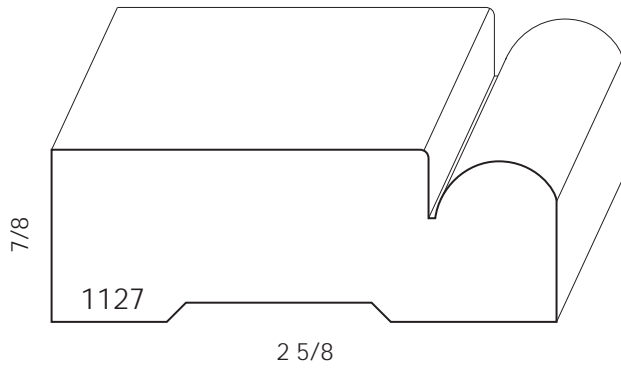

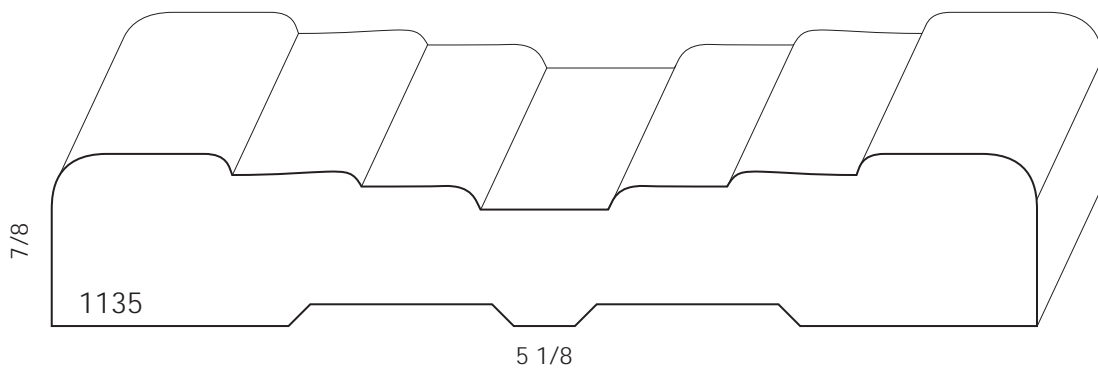
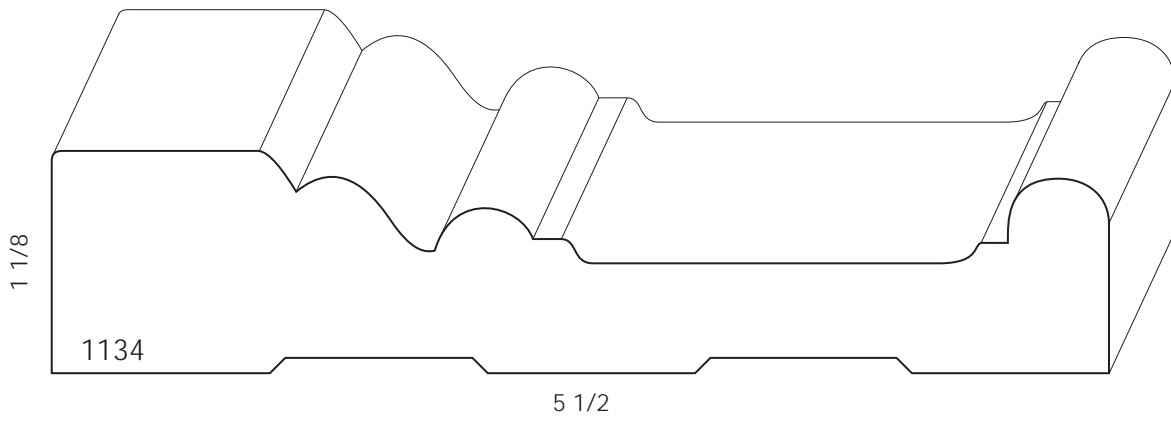
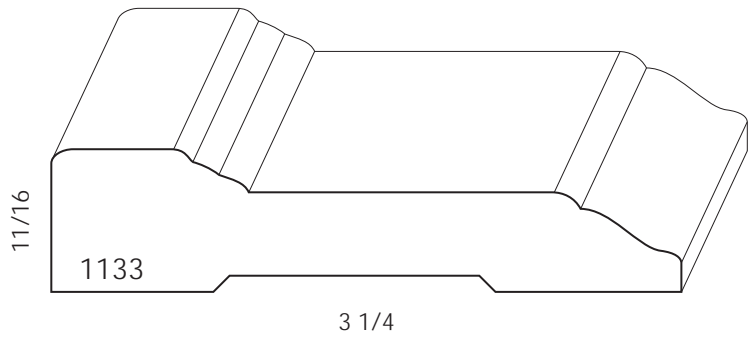
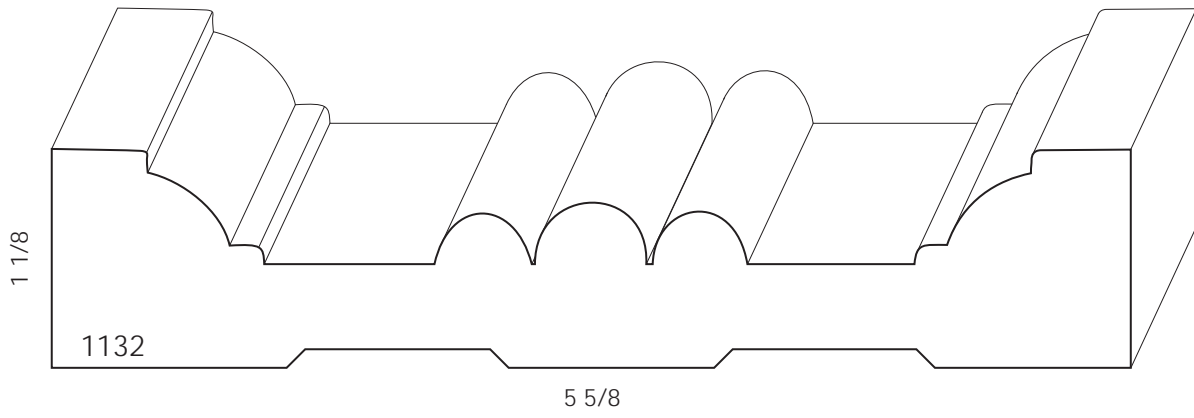

Casing

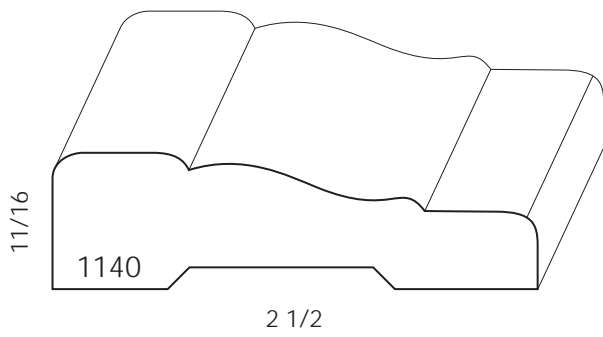
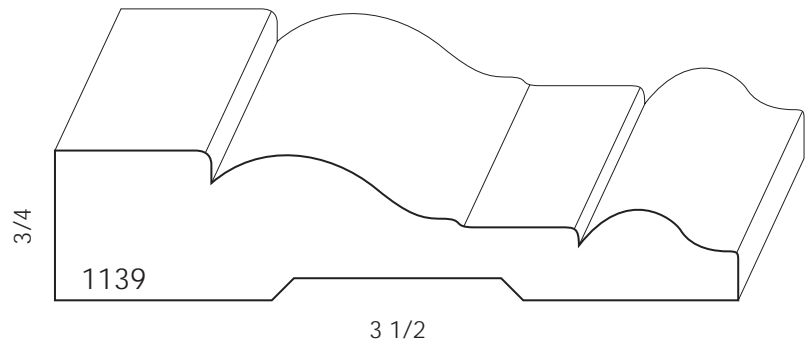
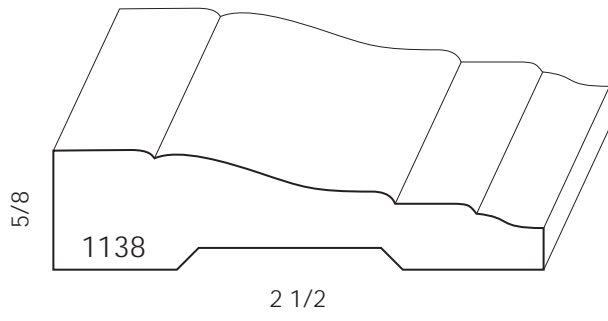
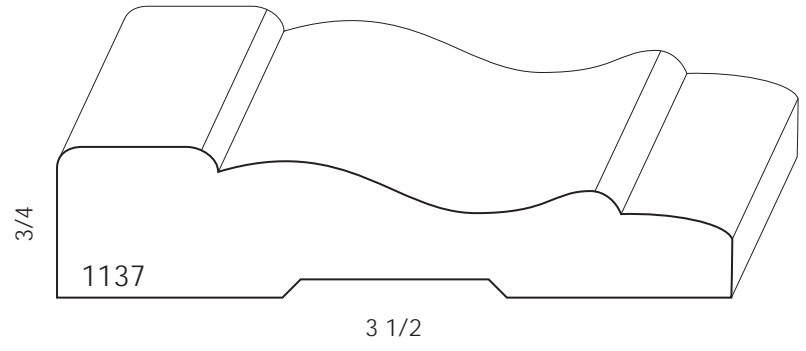
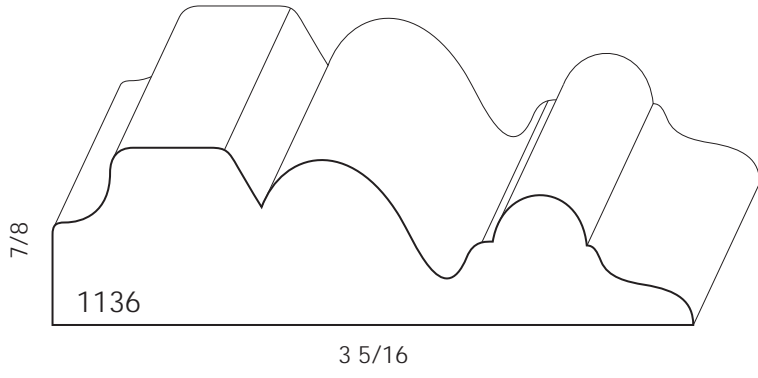

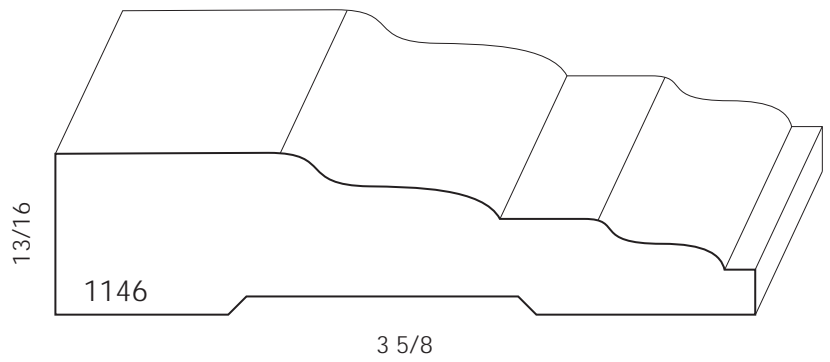
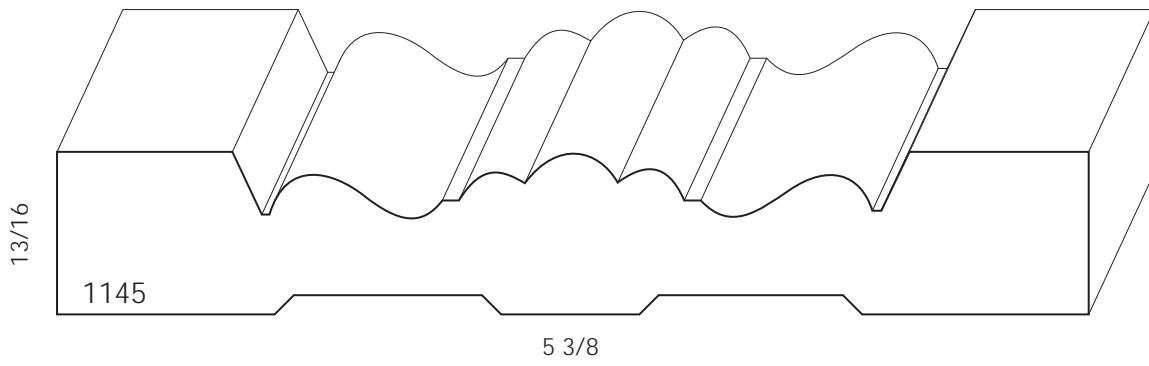
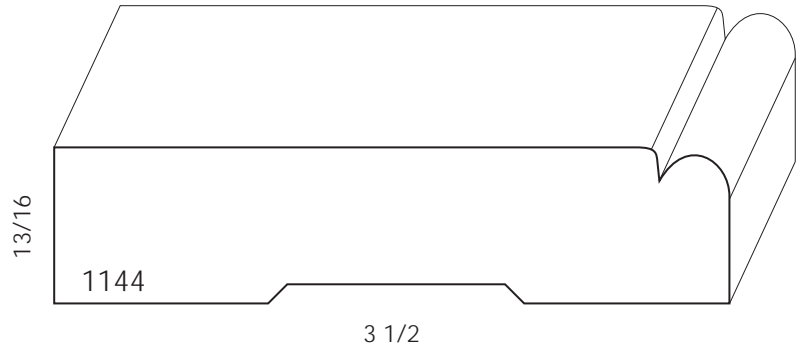
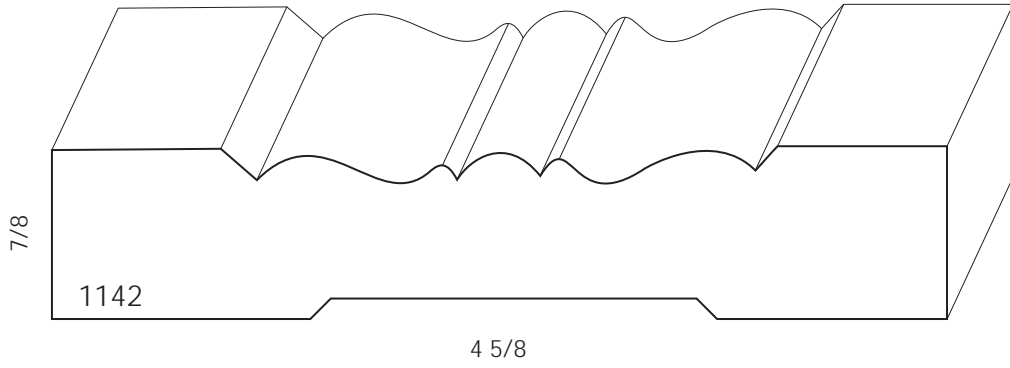
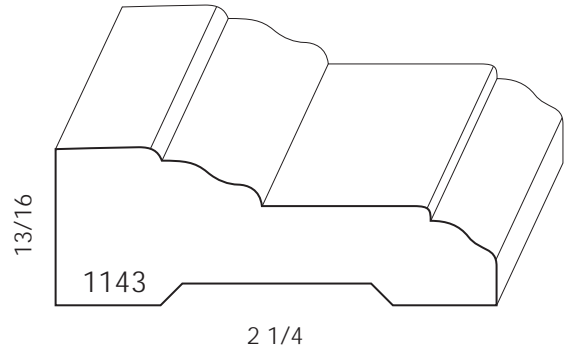
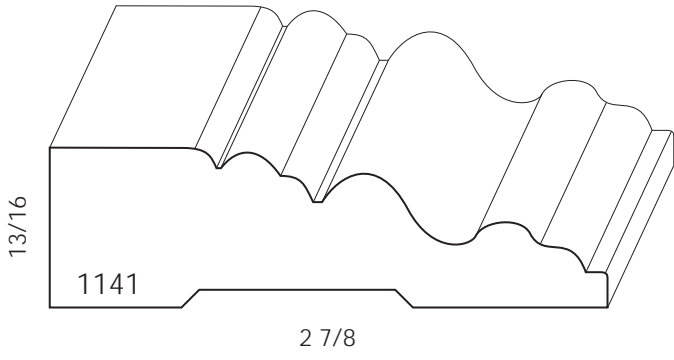

Casing

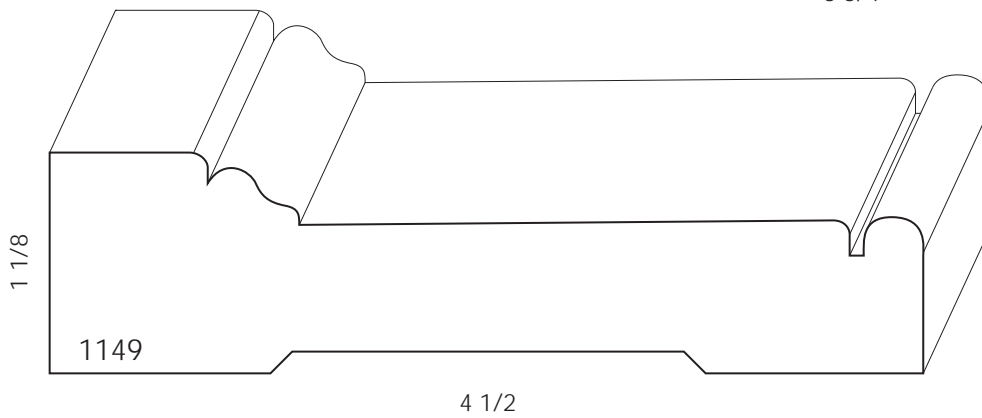
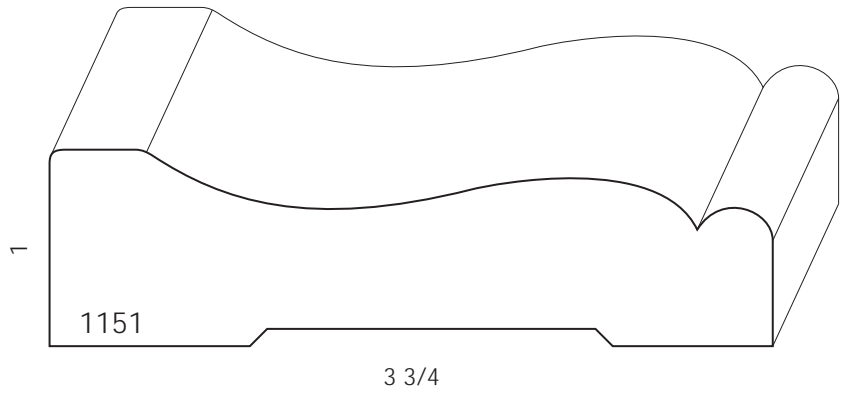
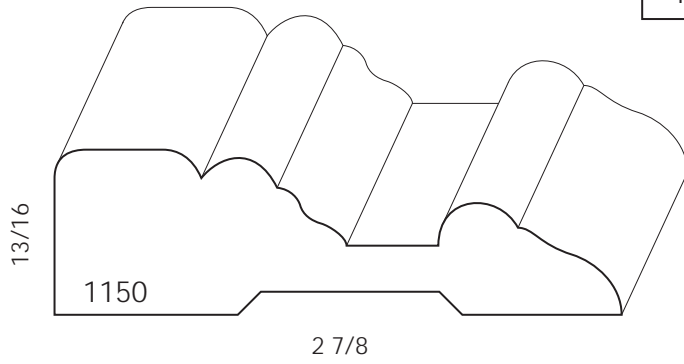
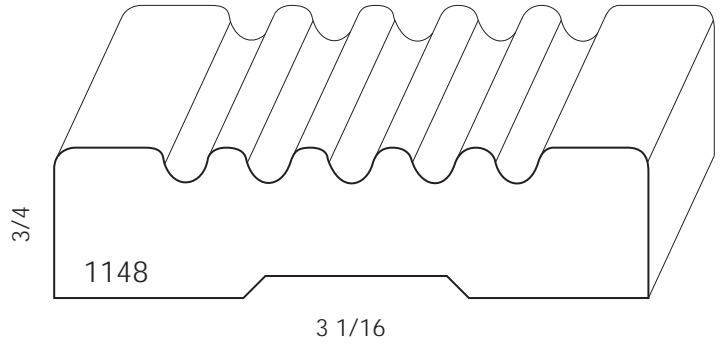
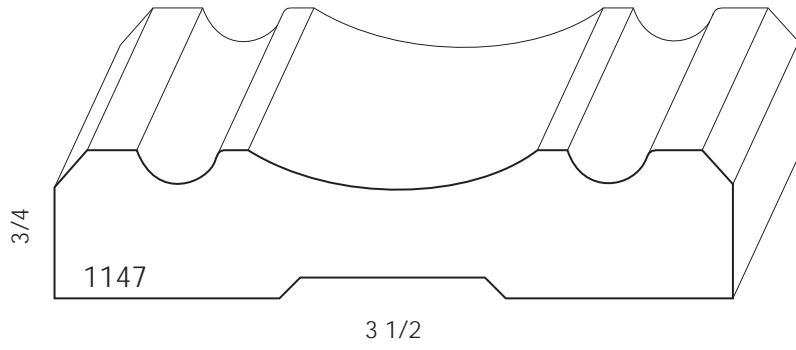

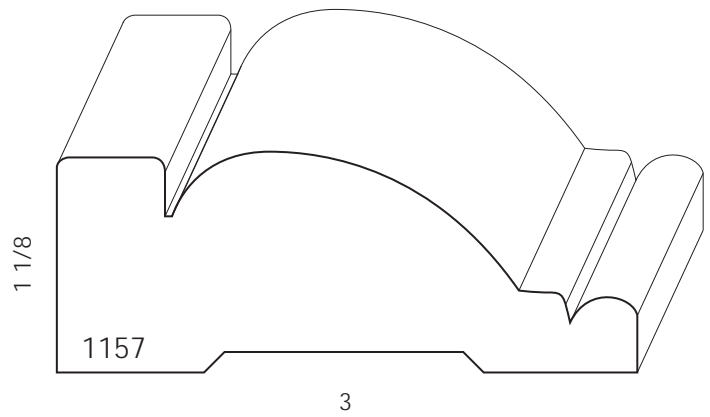
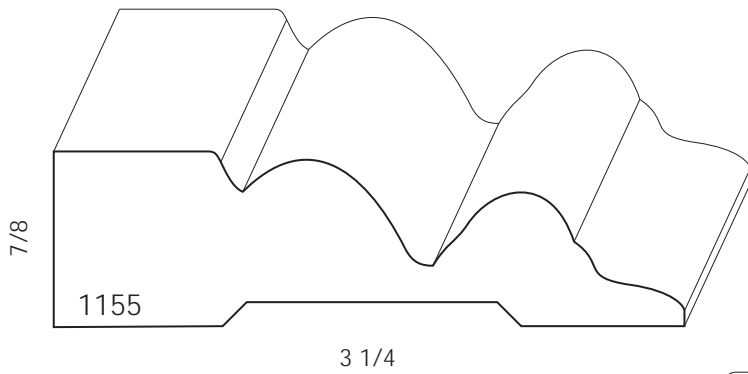
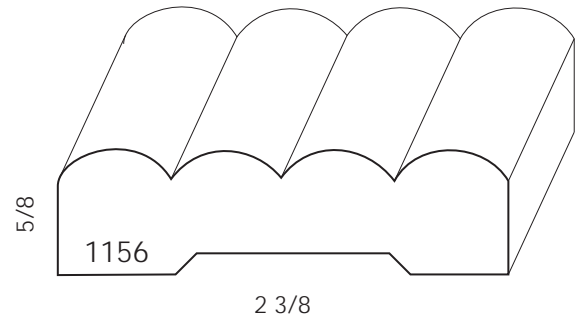
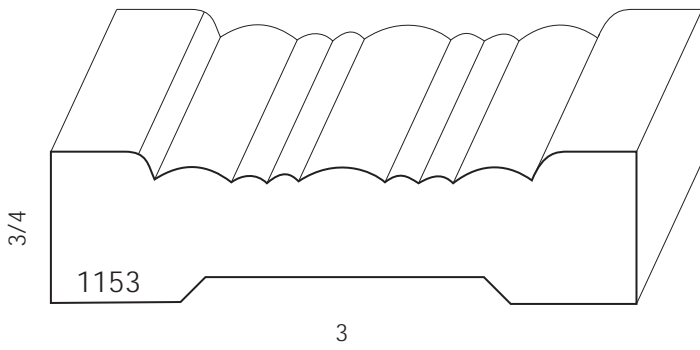
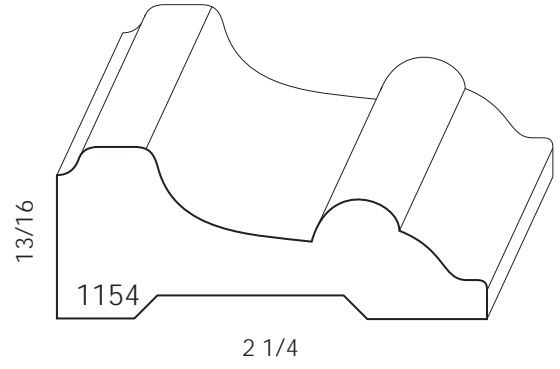
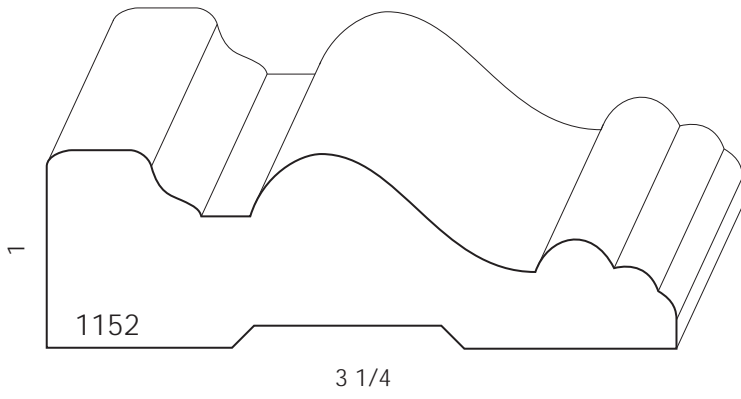

Casing

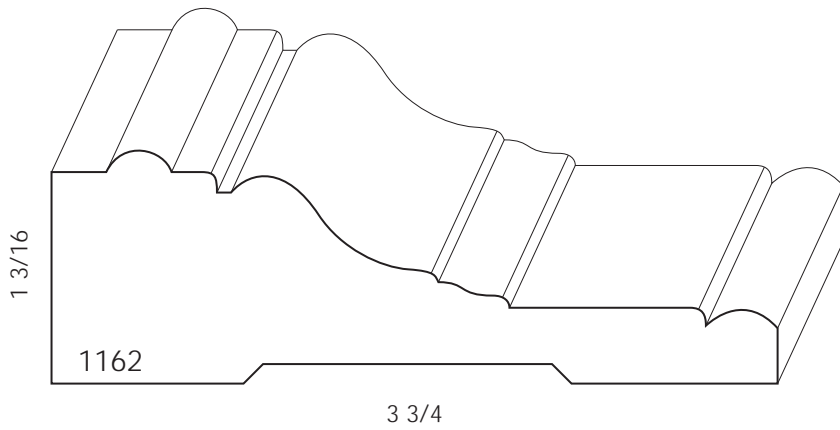
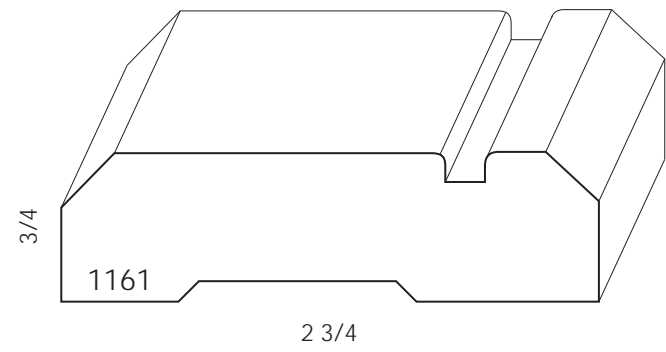
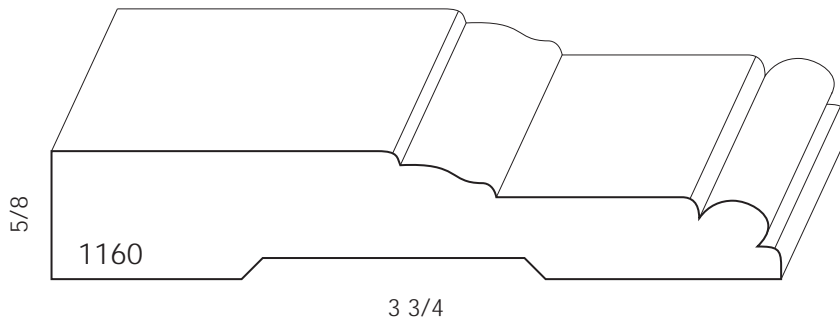
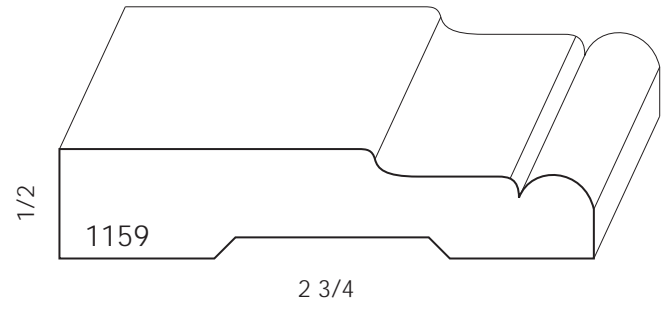
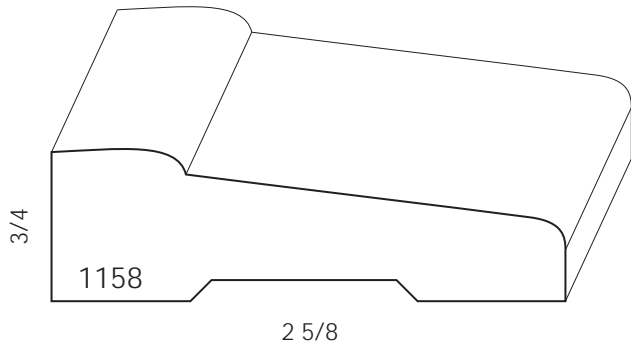

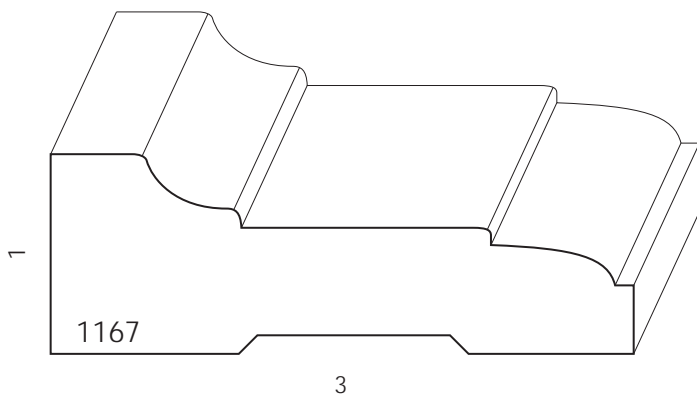
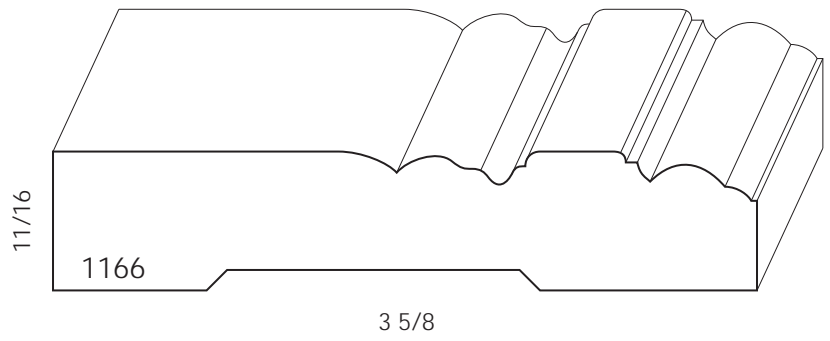
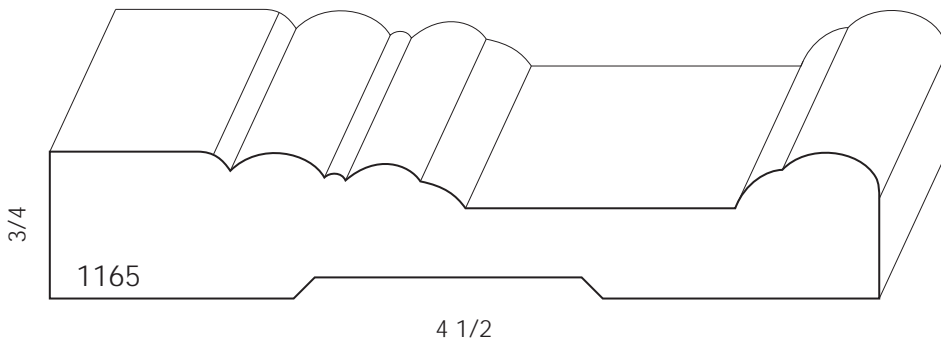
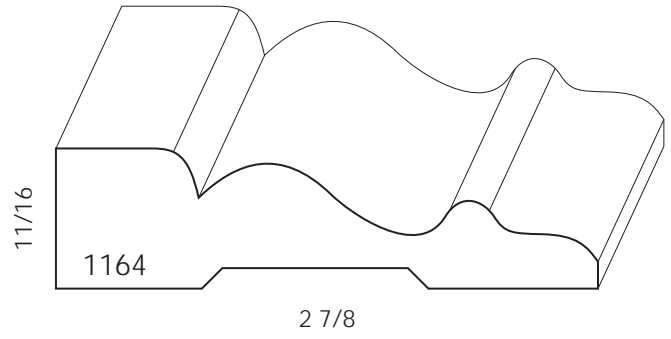
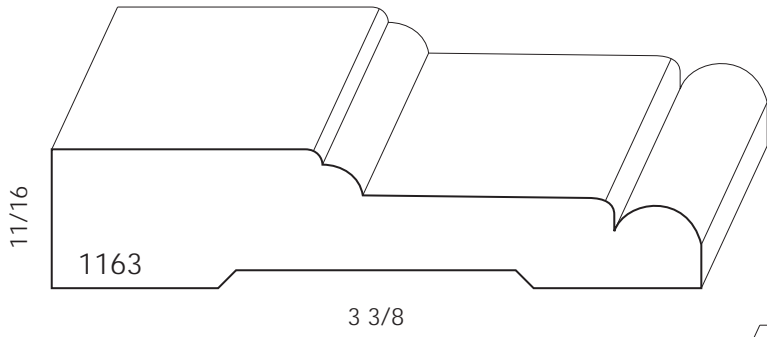

Casing

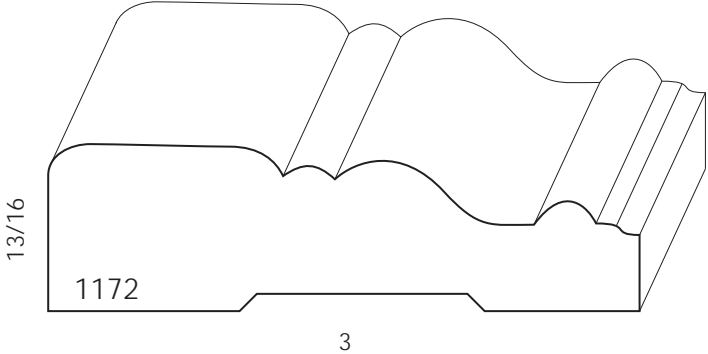
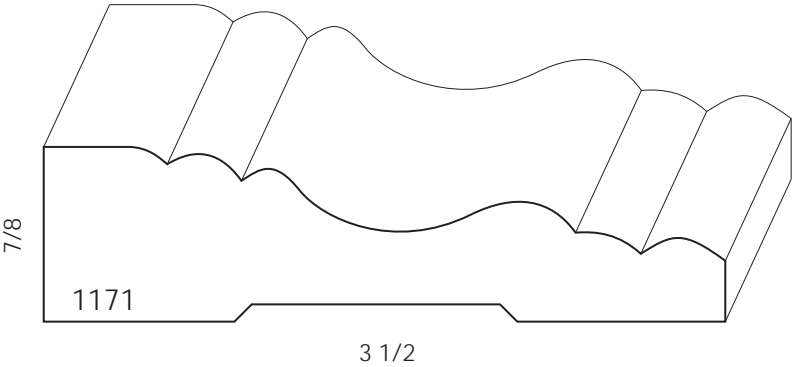
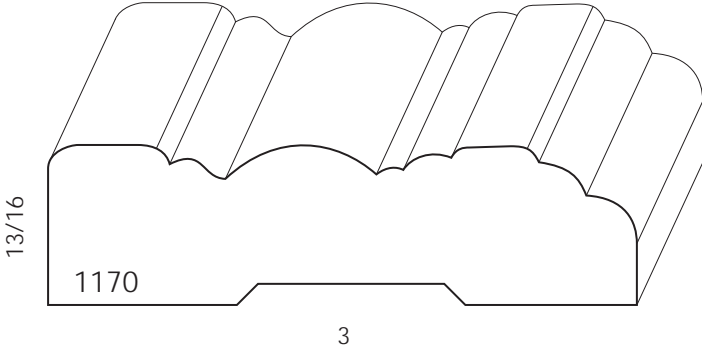
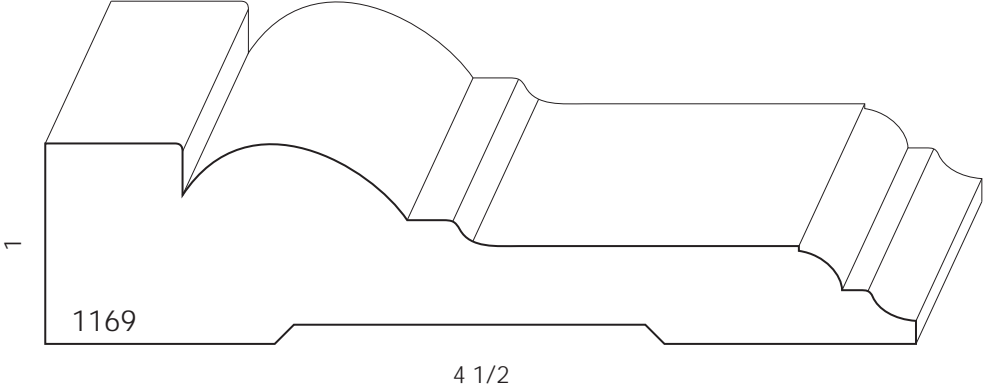
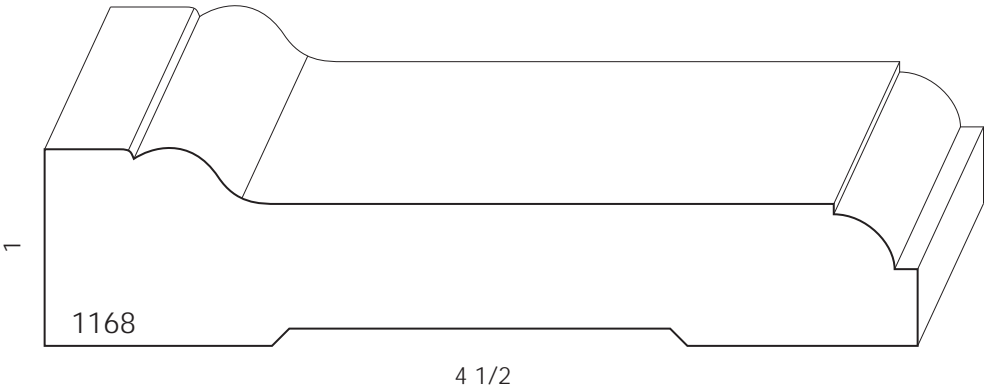

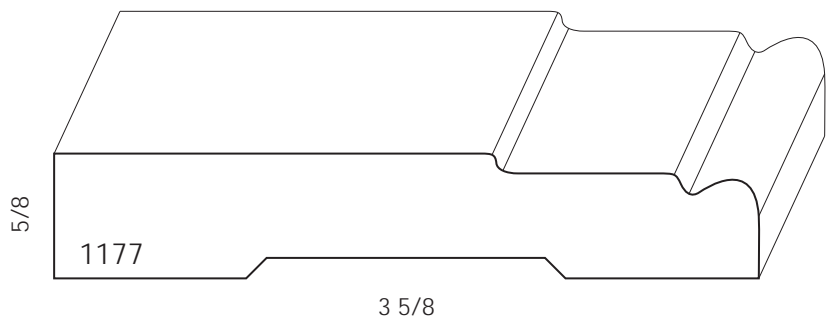
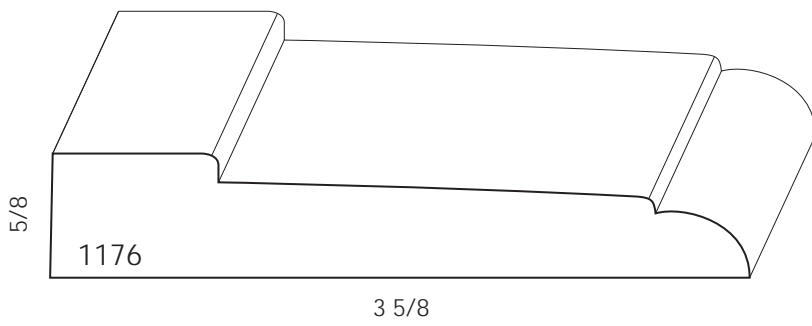
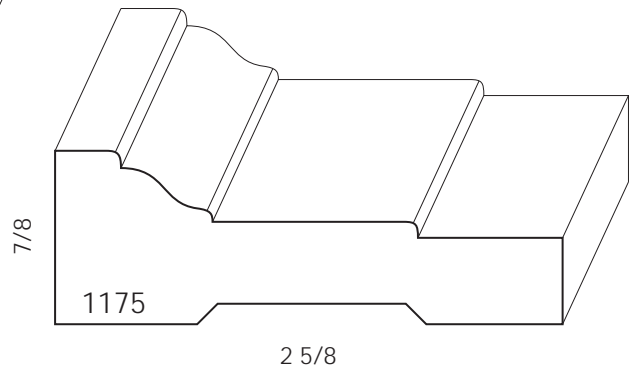
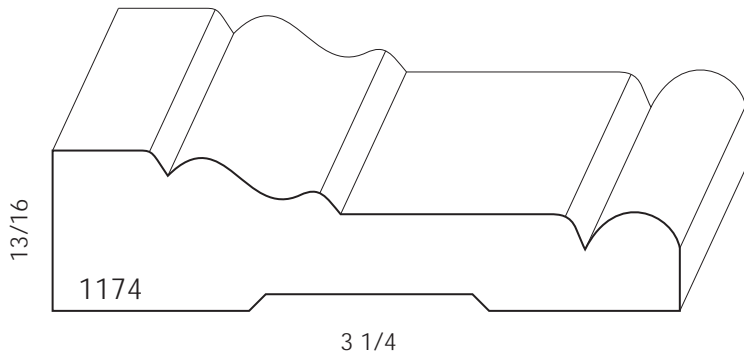
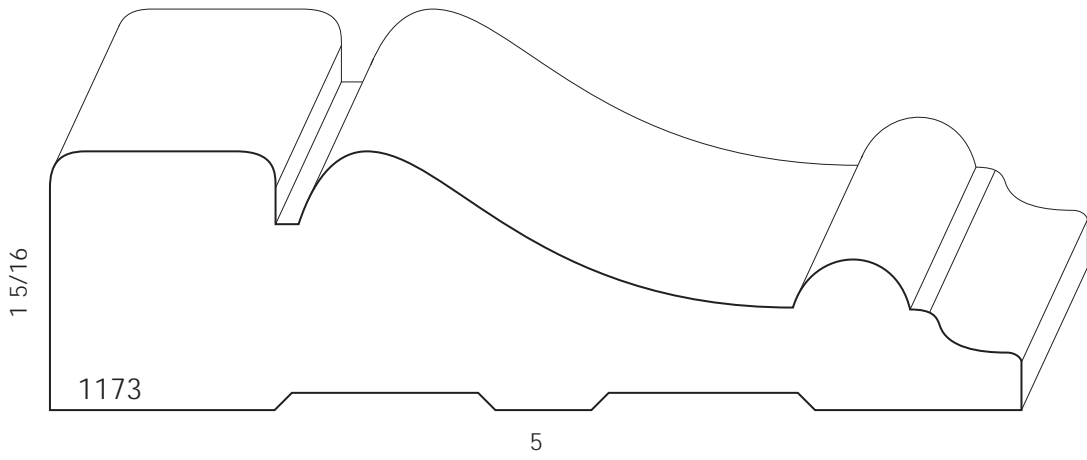

Base

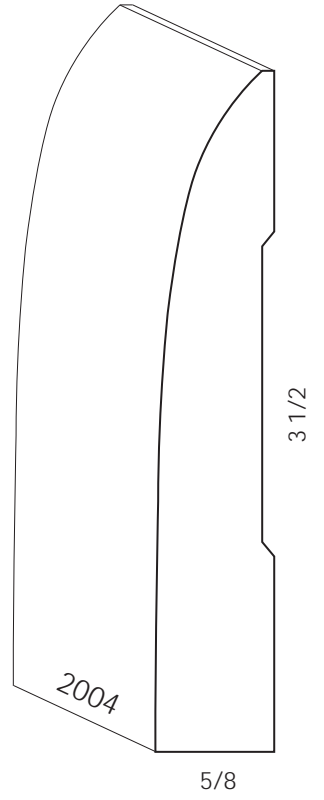
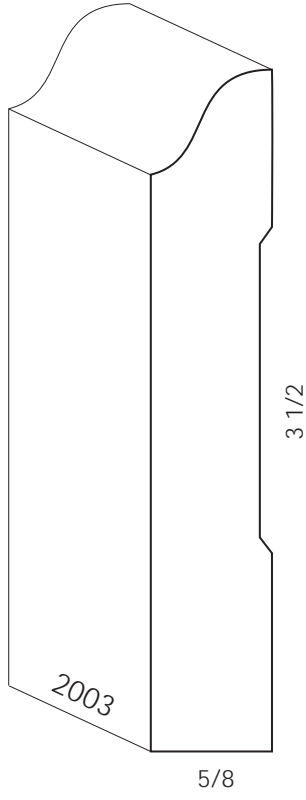
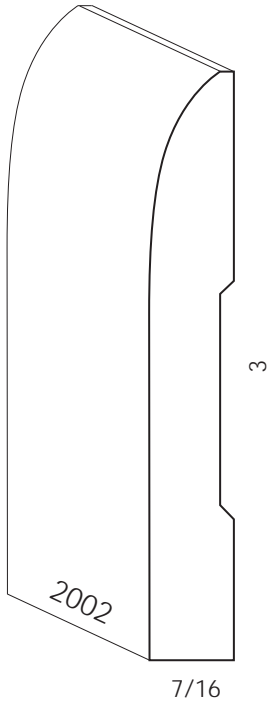
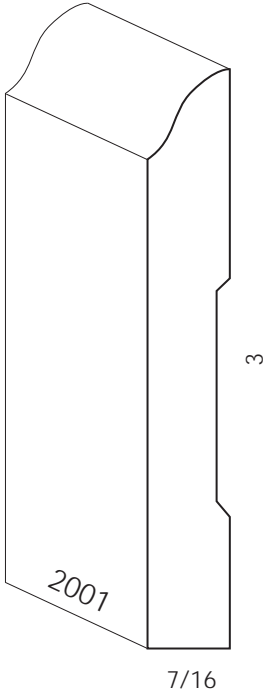

Most baseboards can be modified for height.

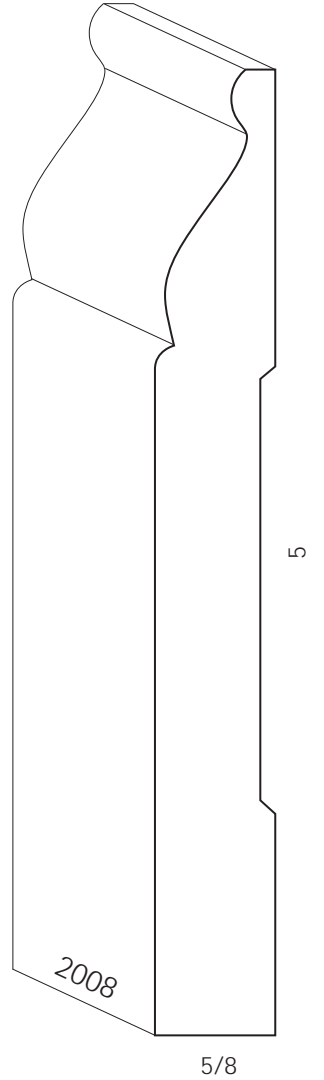
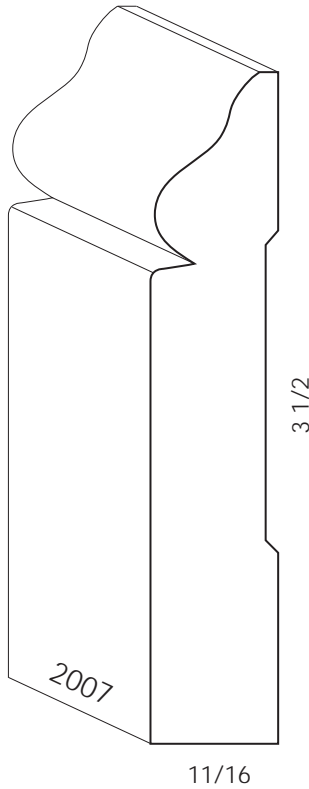
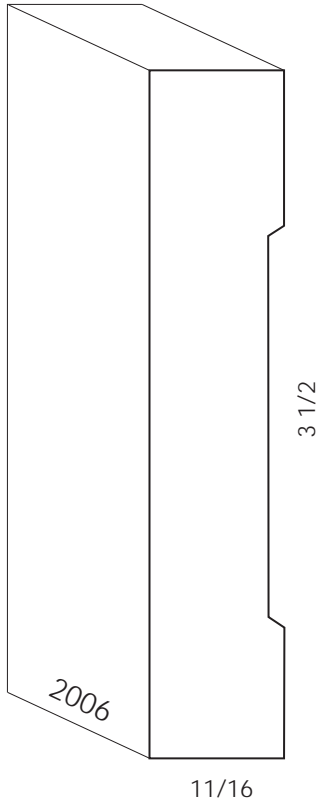
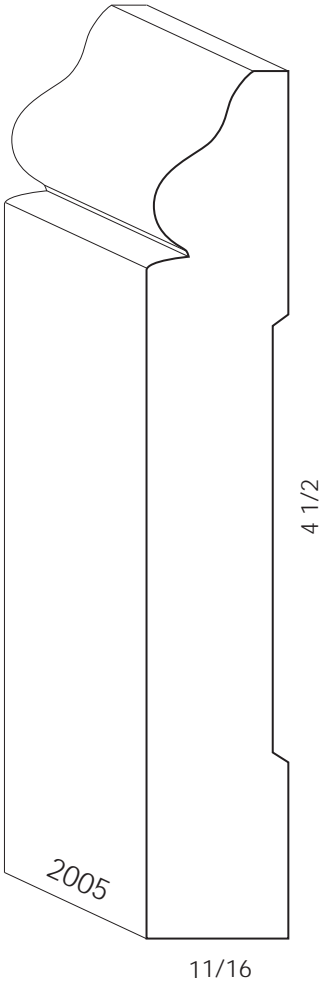

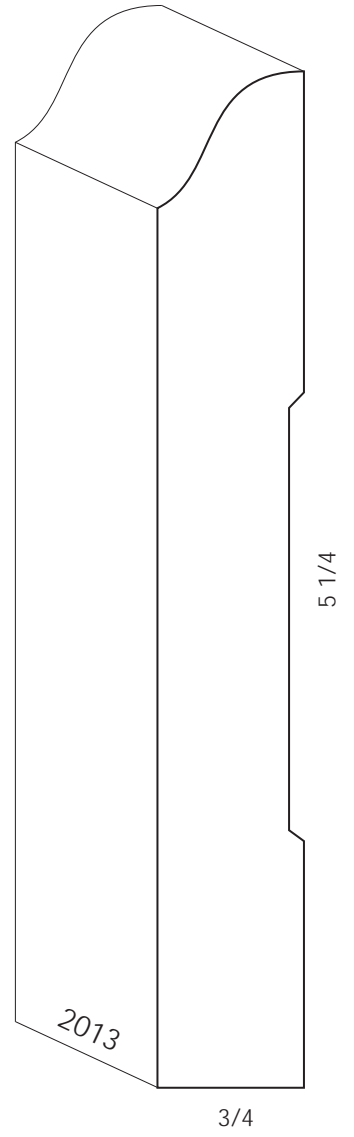
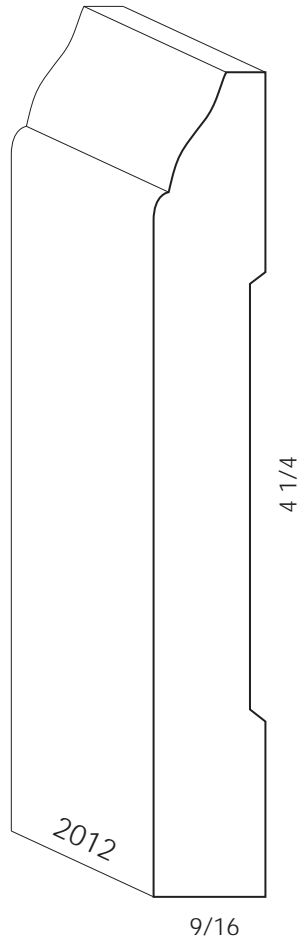
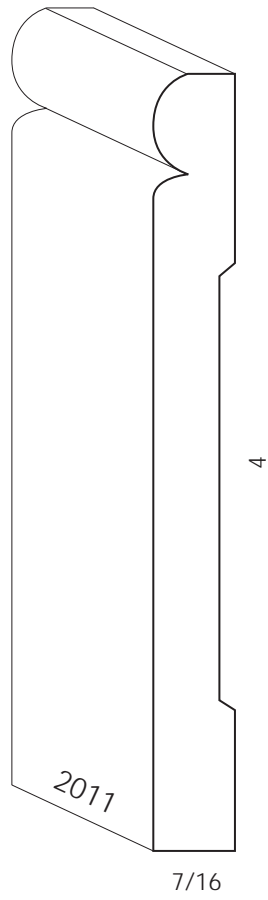
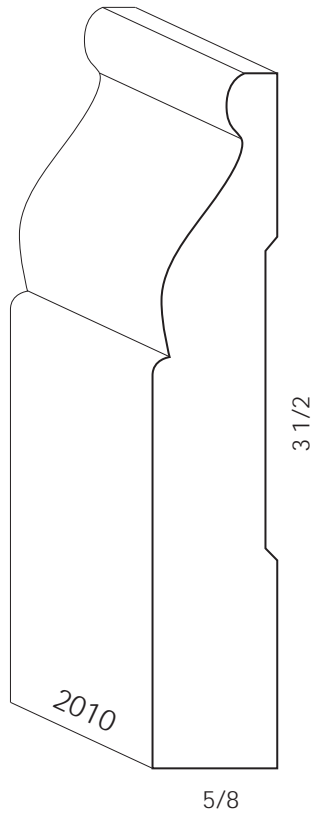
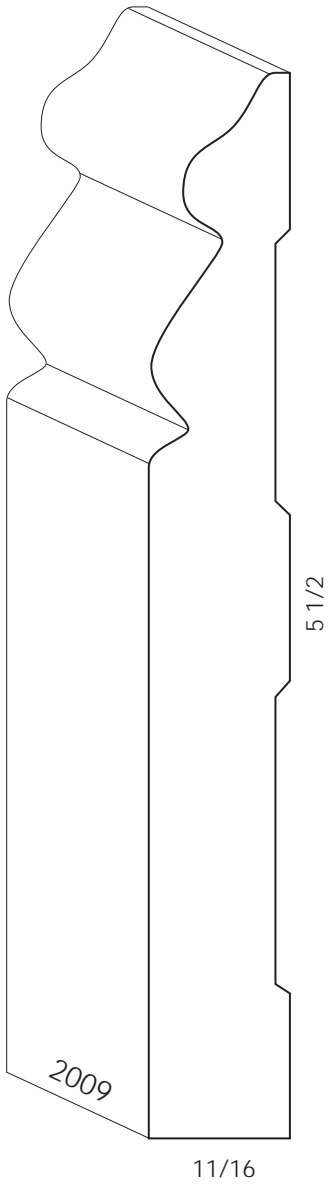

Base

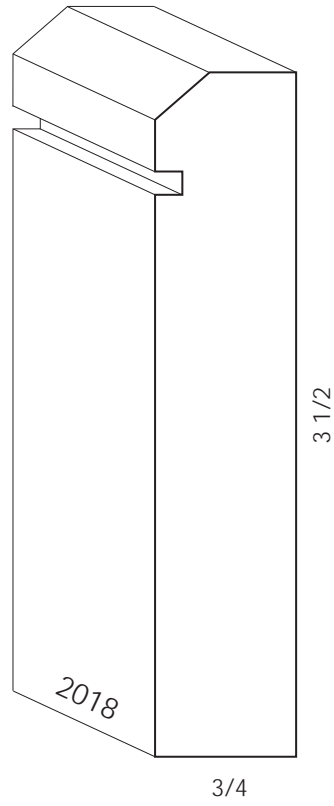
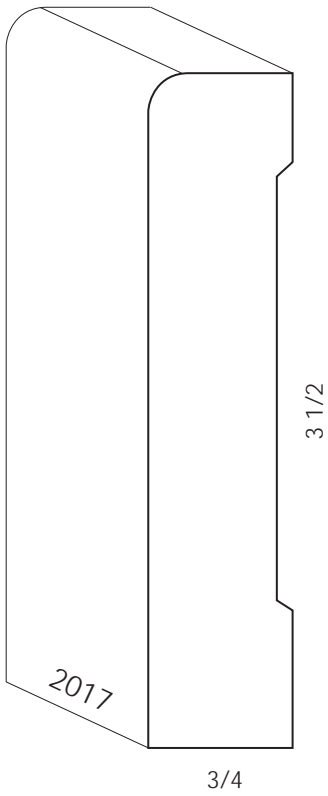
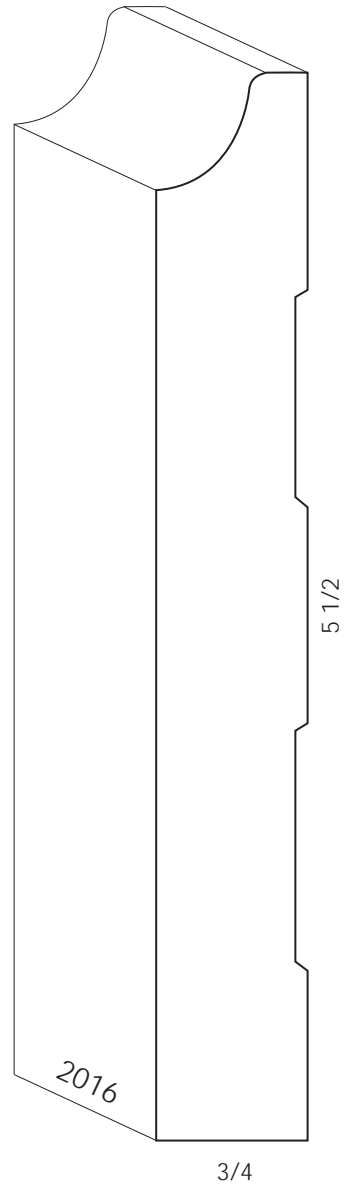
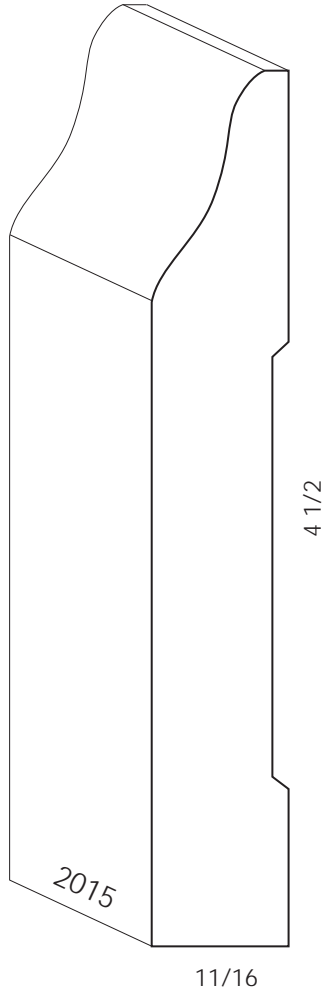
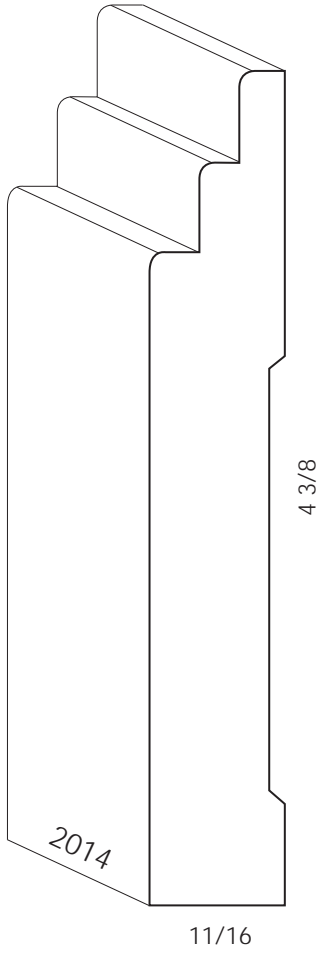

Most baseboards can be modified for height.

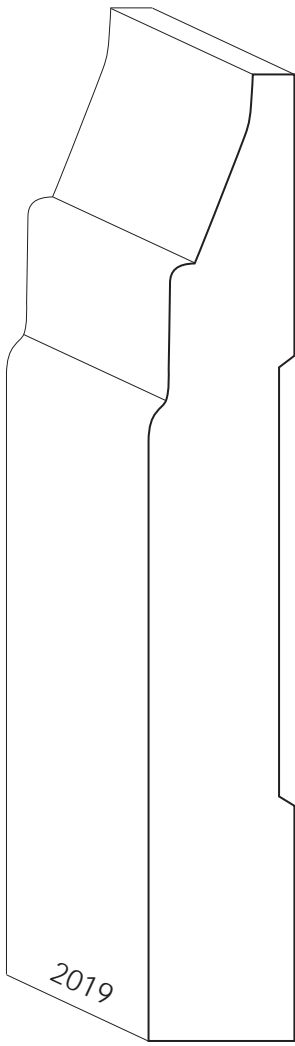

2019

3/4

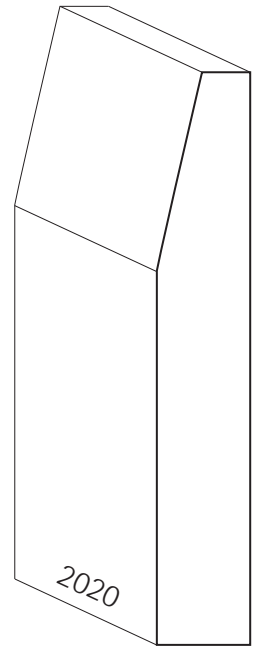

2020

1/2

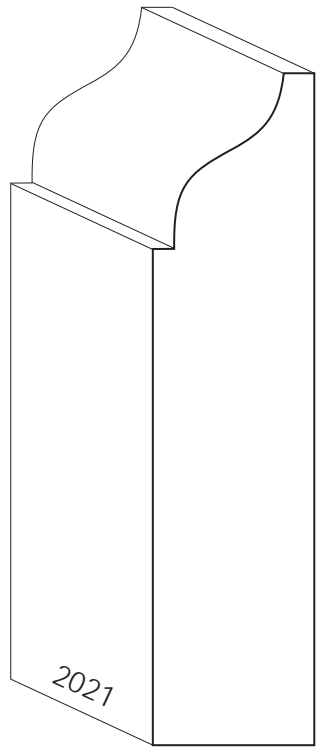

2021

7/8

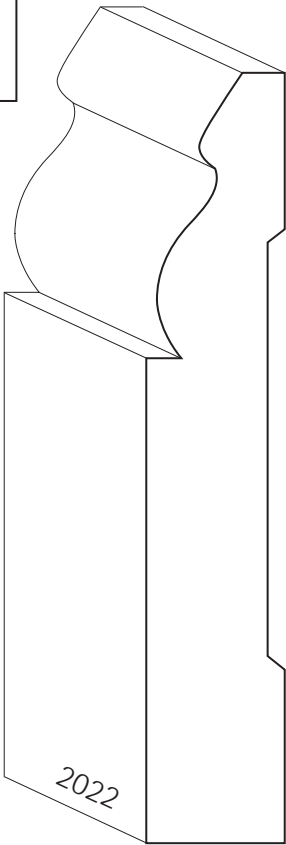

2022

11/16

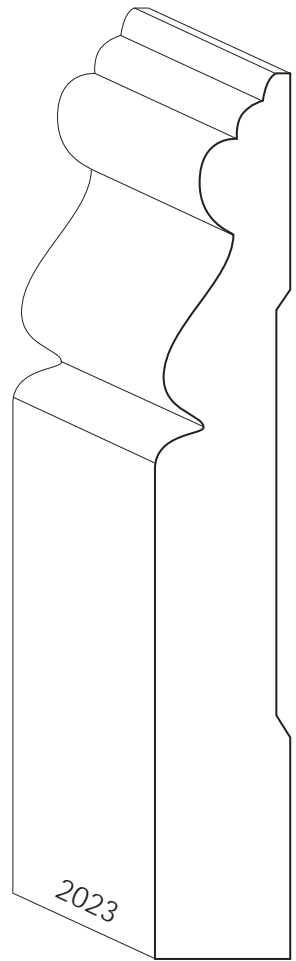

2023

11/16

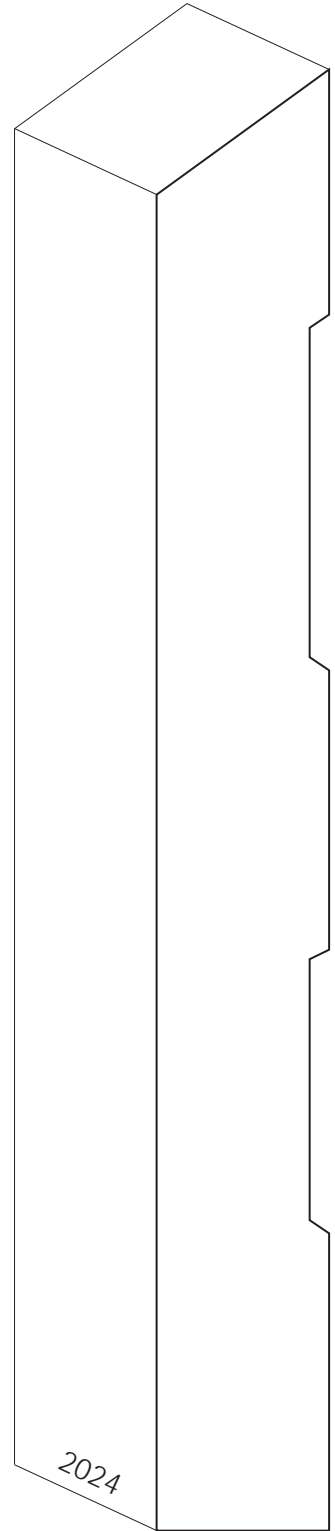

2024

7/8

Base

7 1/2

Base

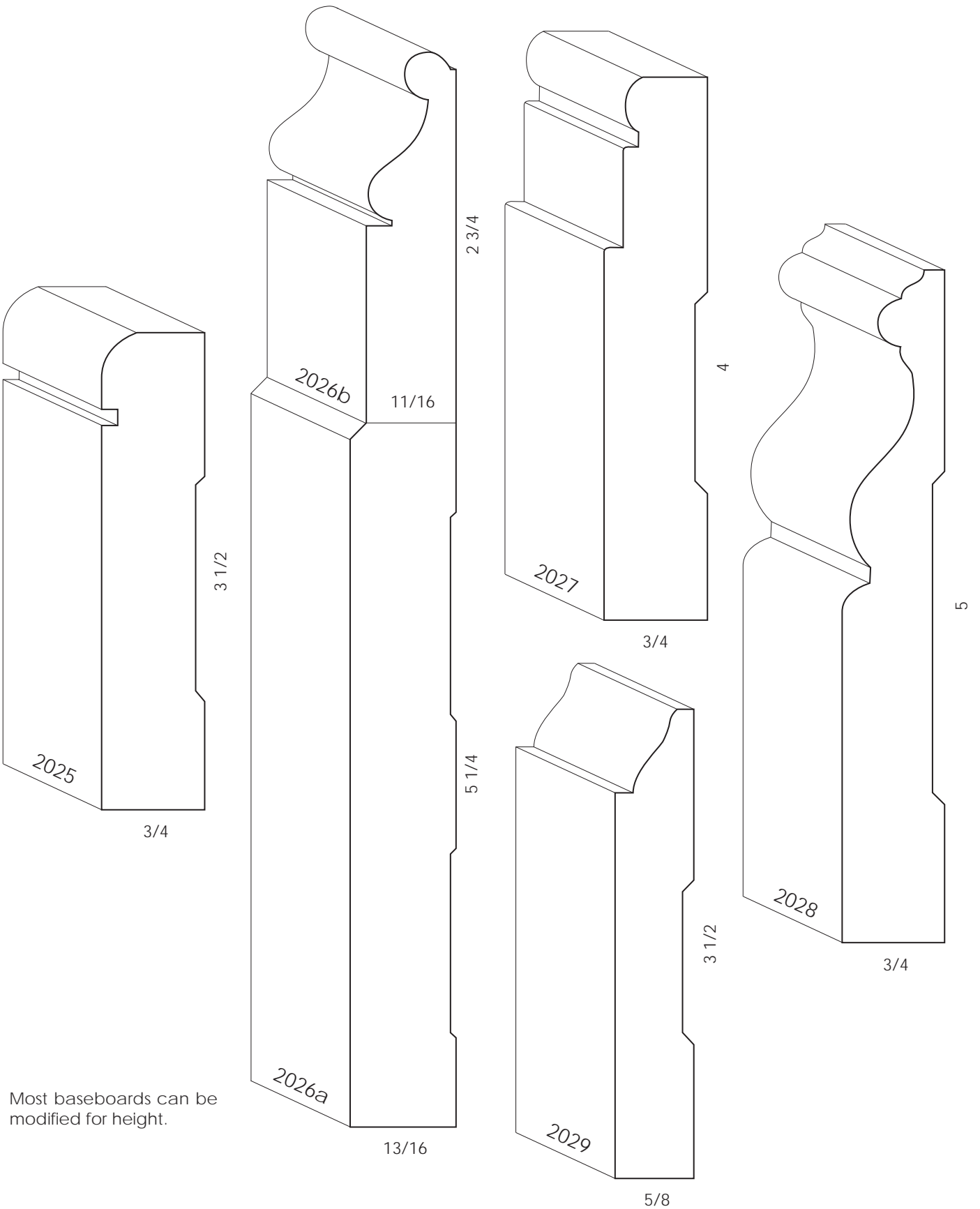

Most baseboards can be modified for height.

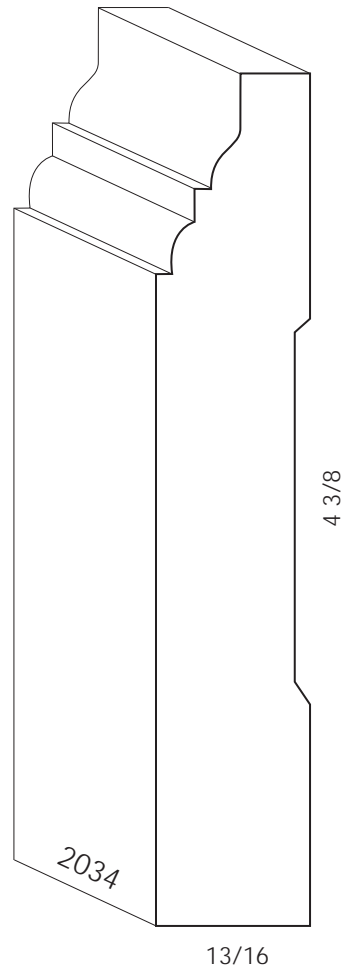
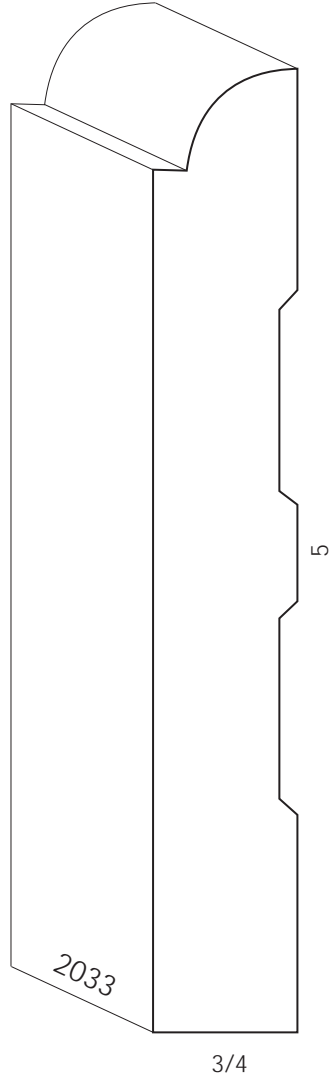
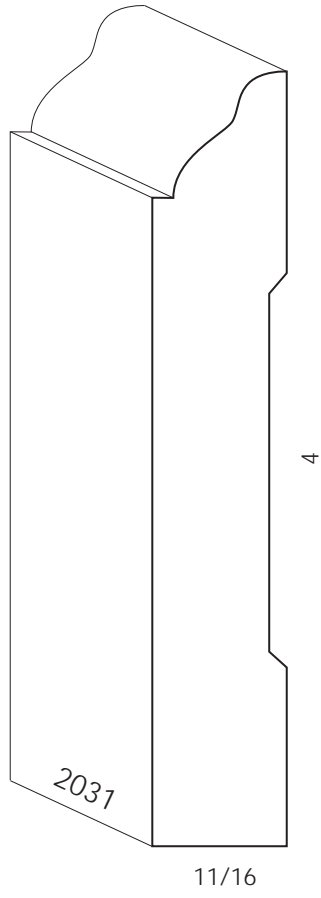
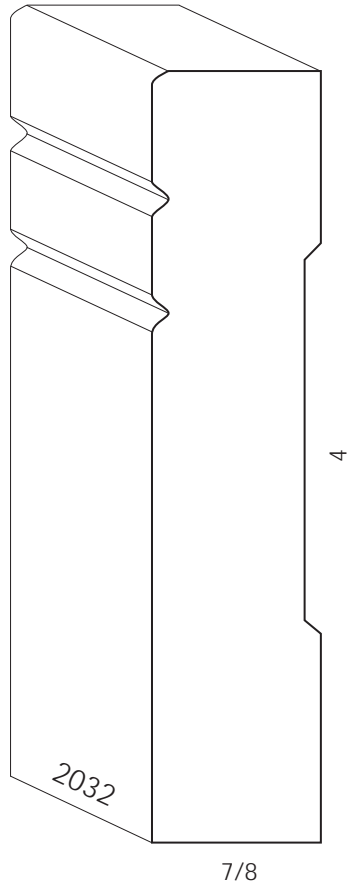
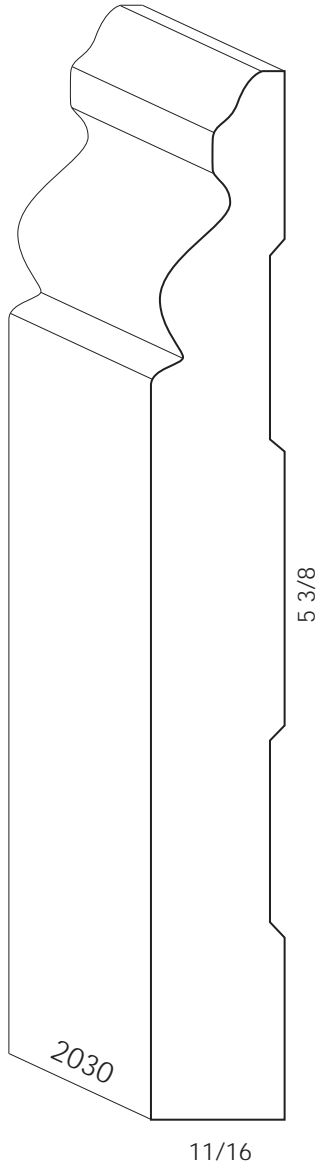

Base

Base

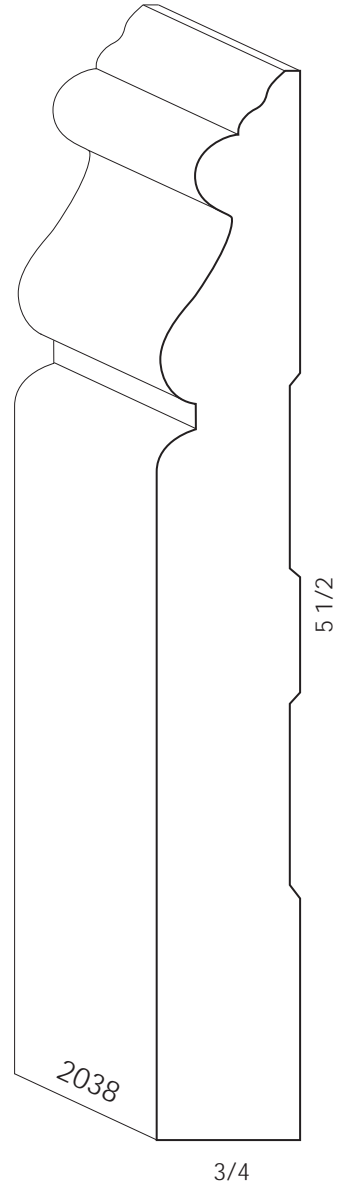
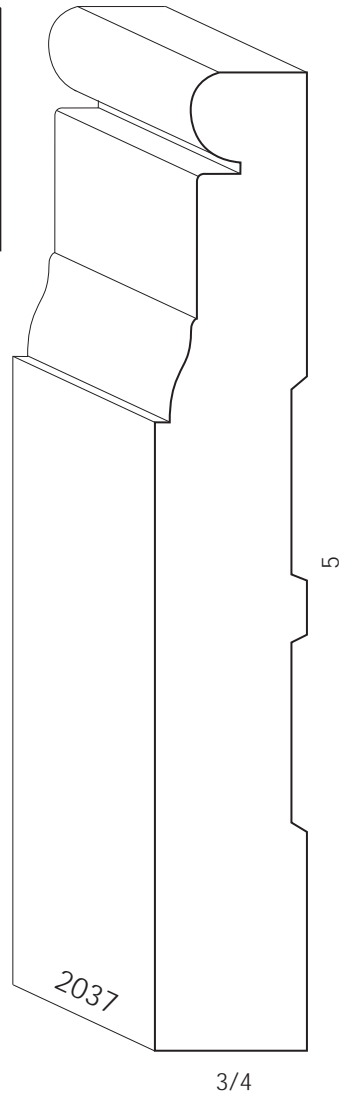
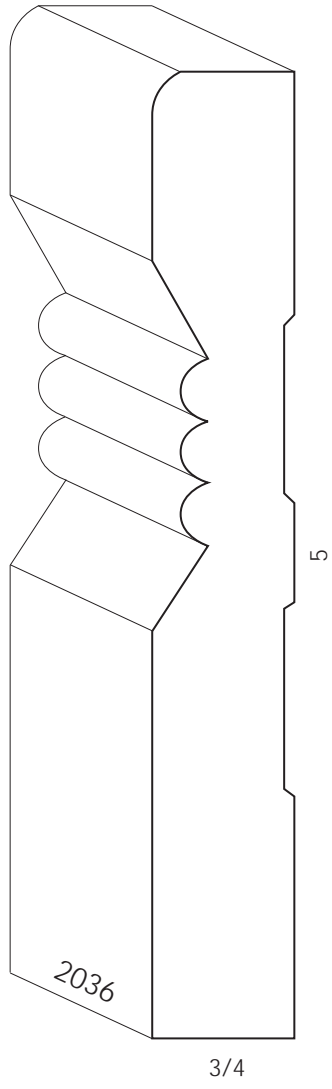
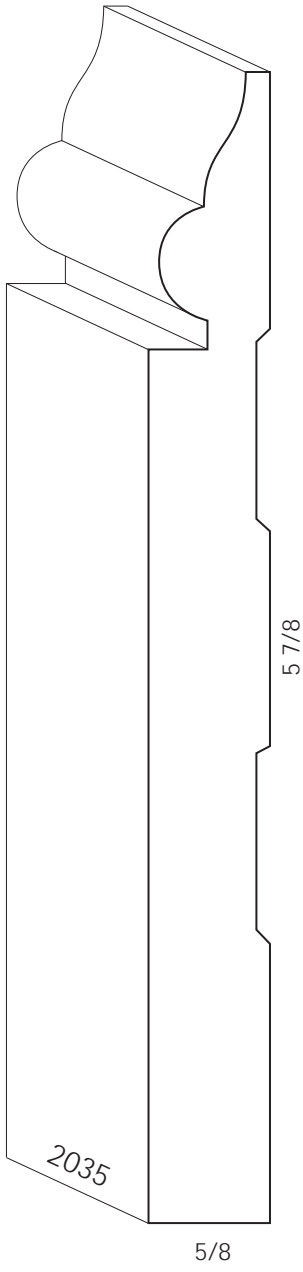

Most baseboards can be modified for height.

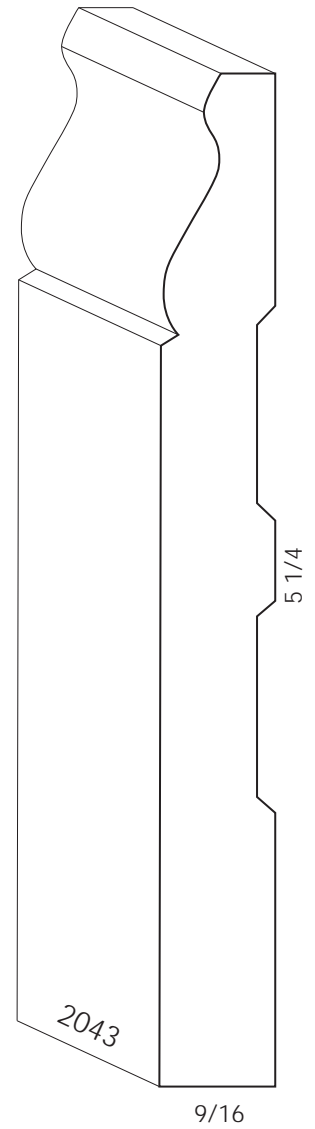
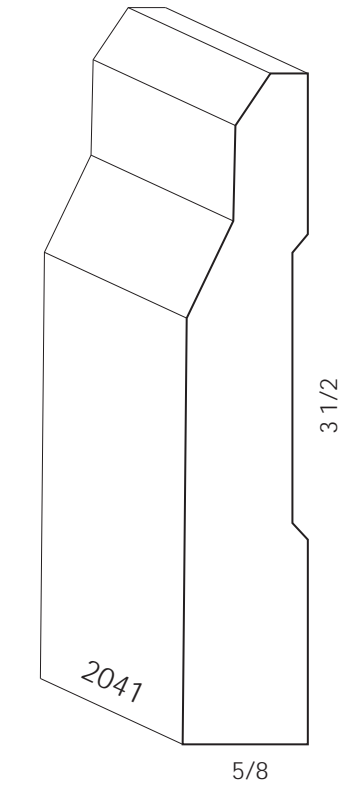
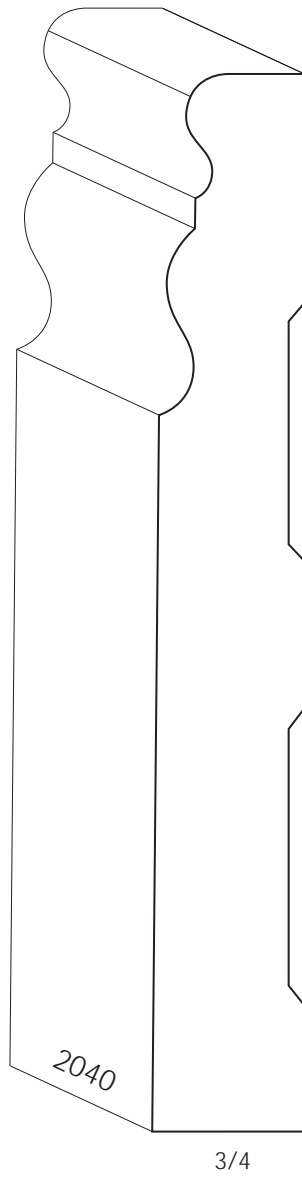
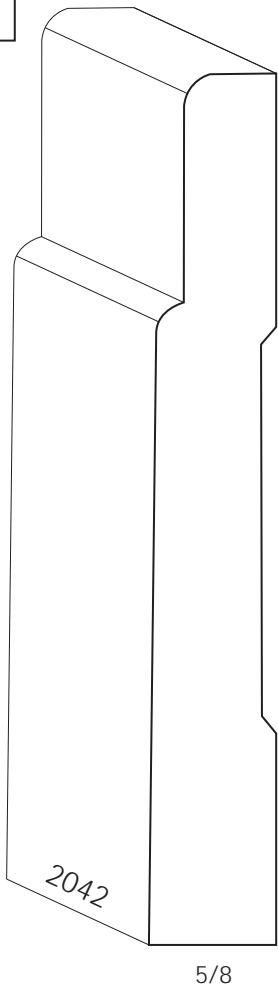
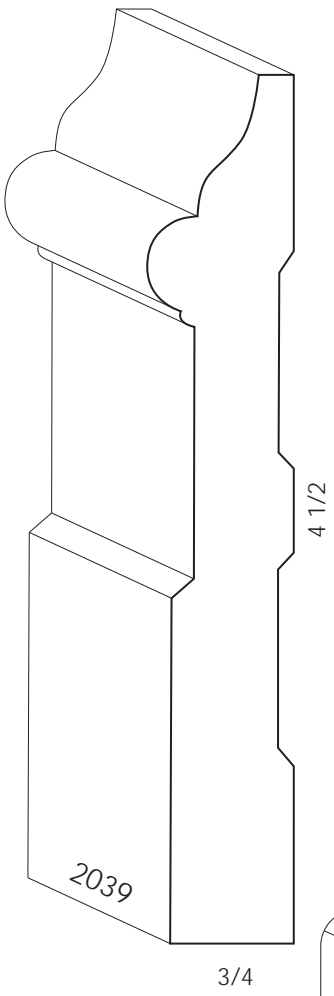

Base

Base

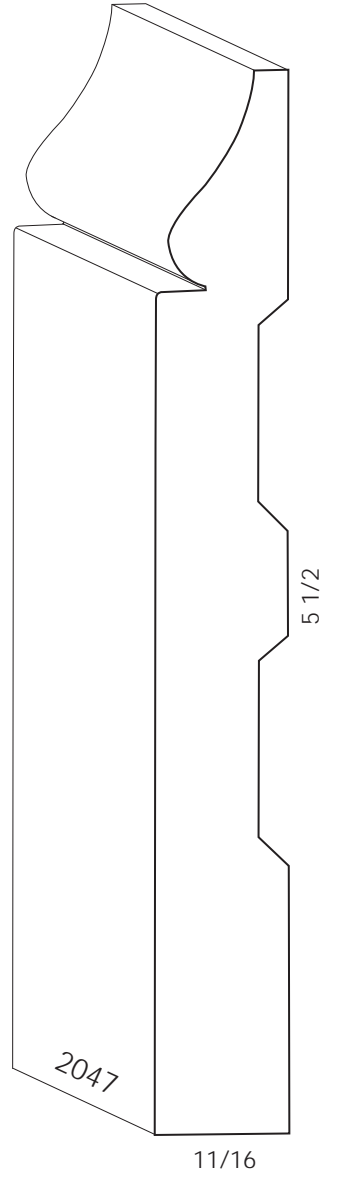
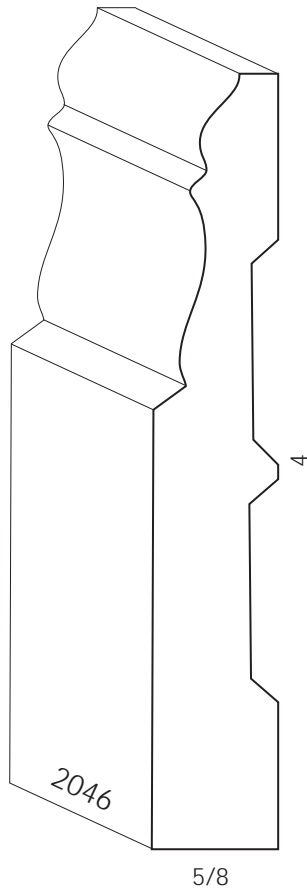
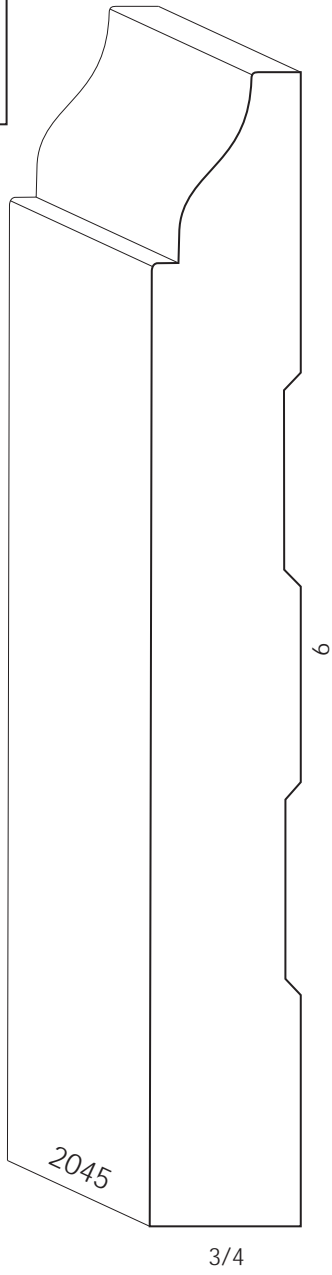
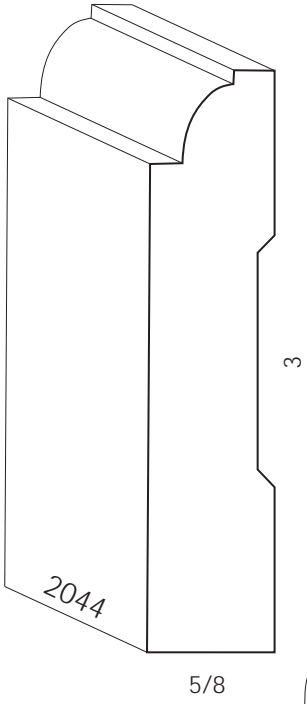

Most baseboards can be modified for height.

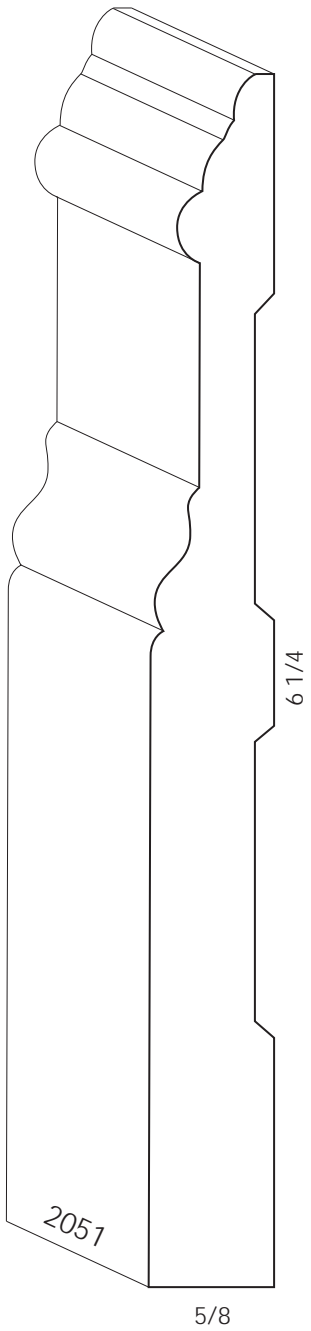
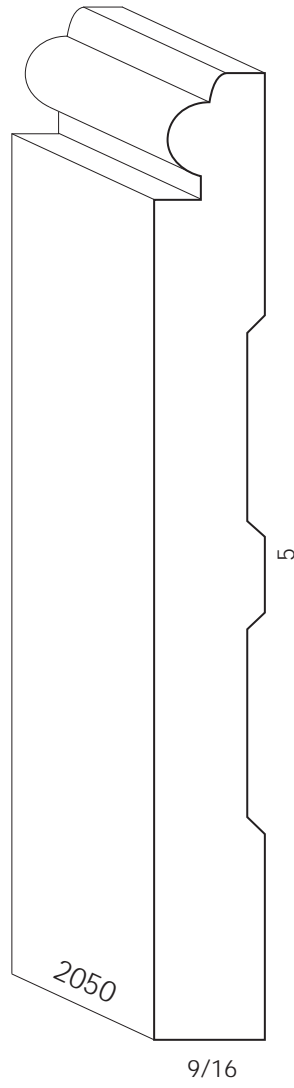
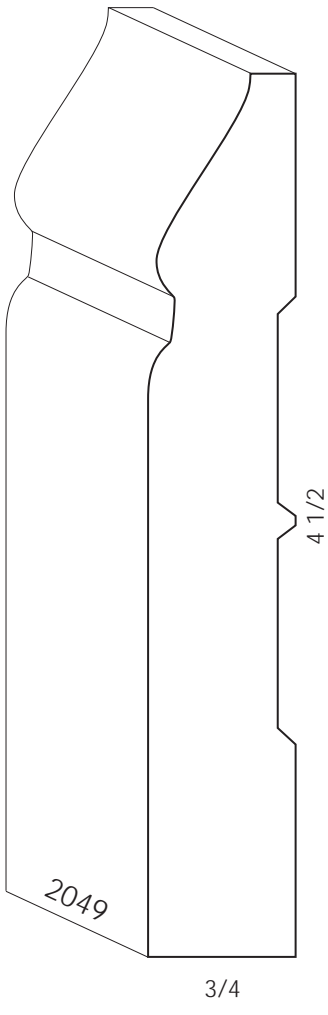
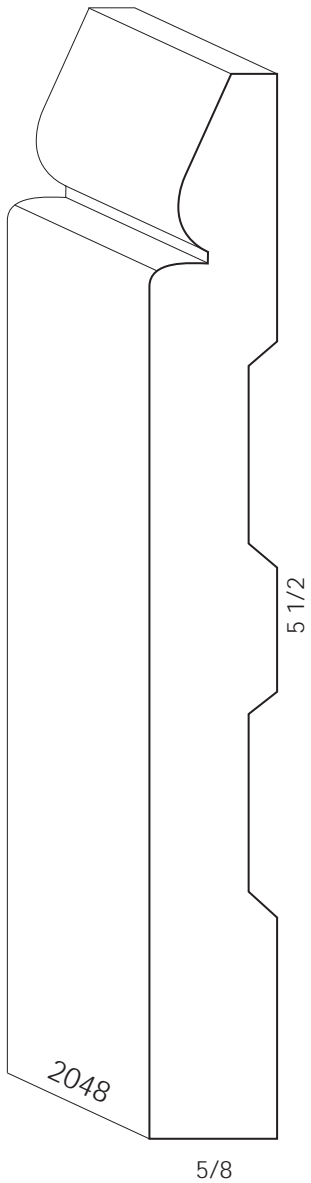

Base

Base

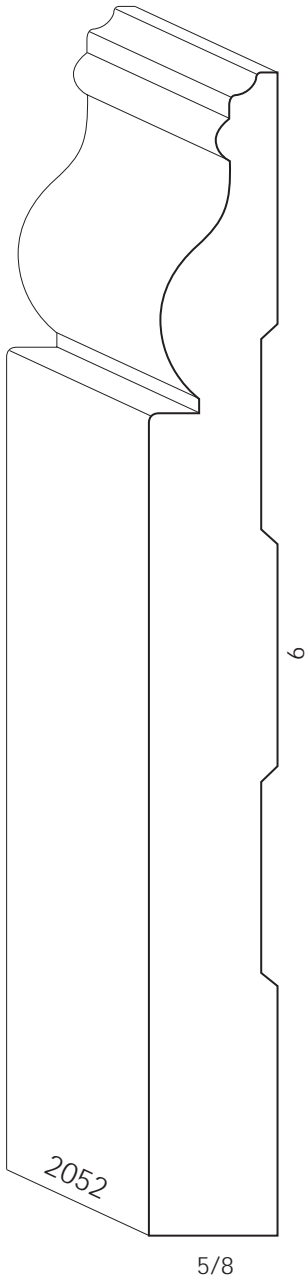

2052

5/8

6

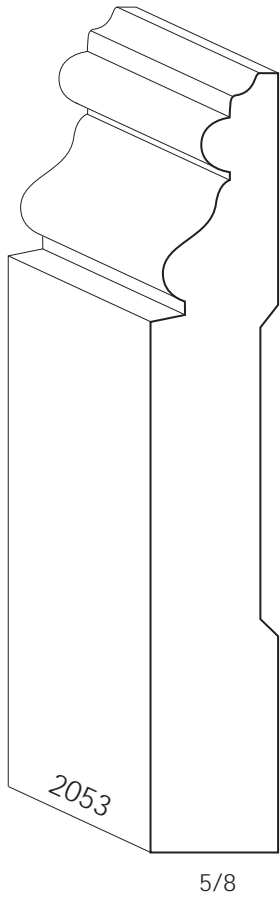

2053

5/8

4

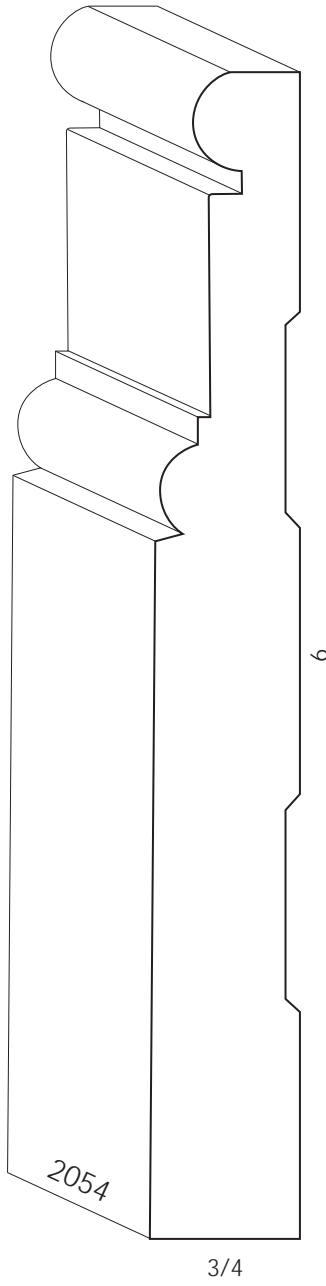

2054

3/4

6

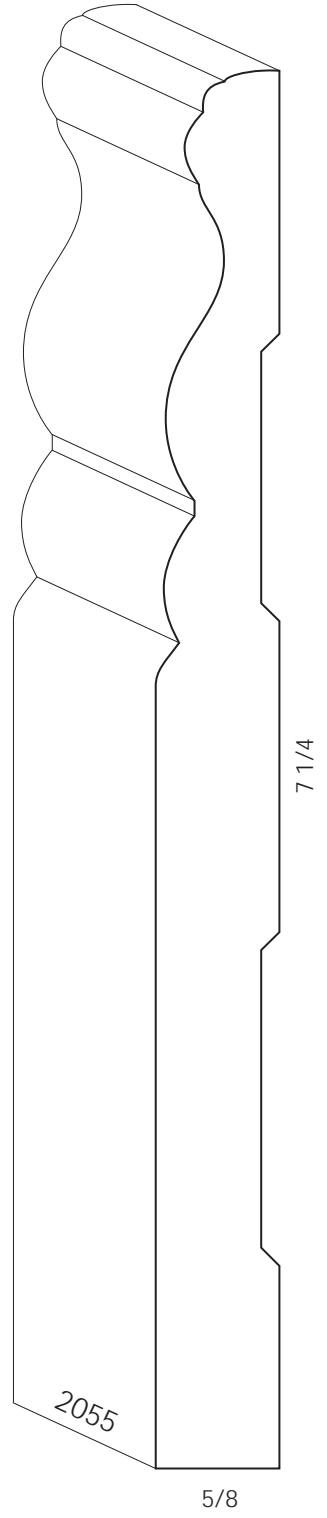

2055

5/8

7 1/4

Most baseboards can be modified for height.

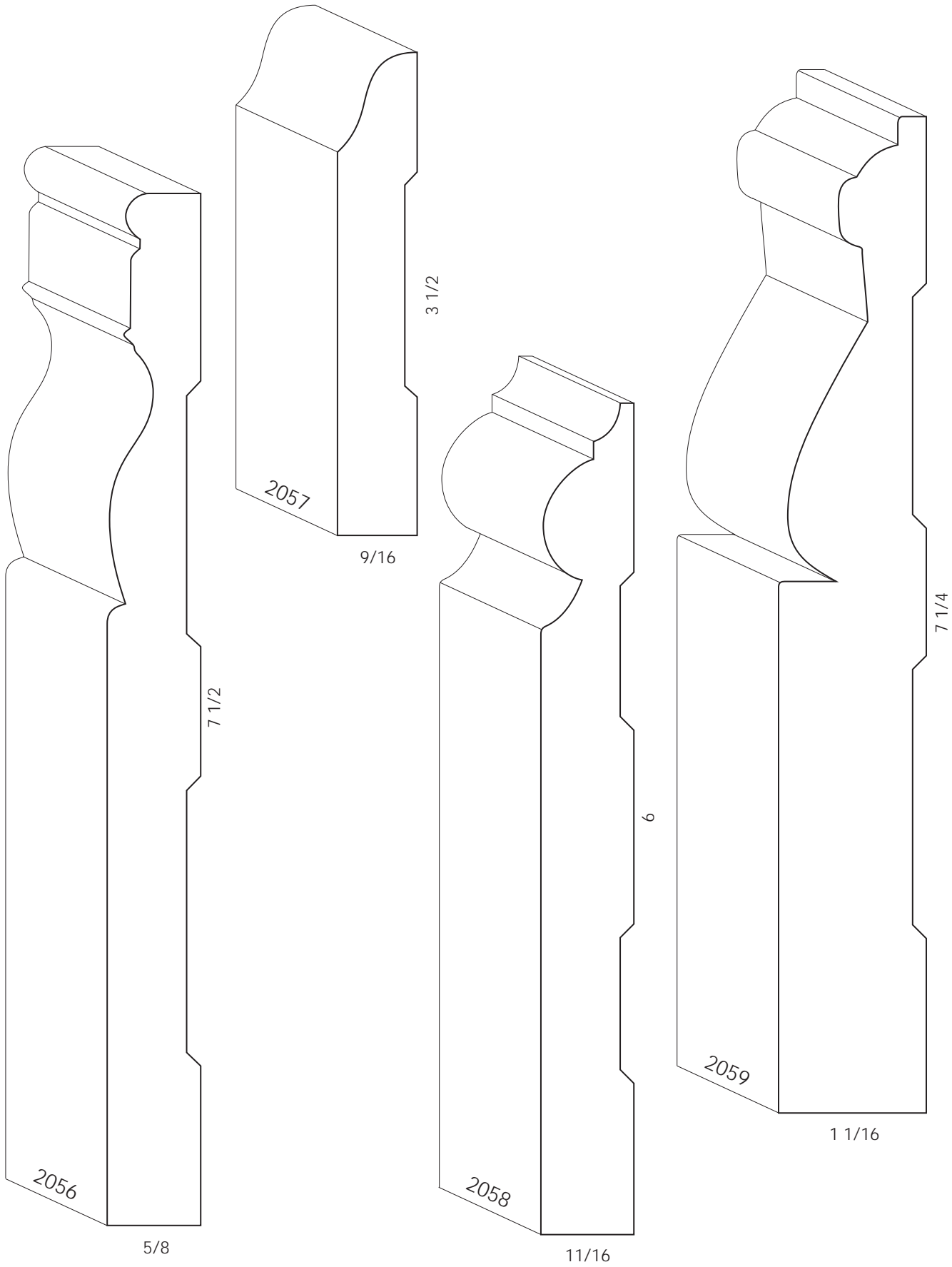

Base

Base

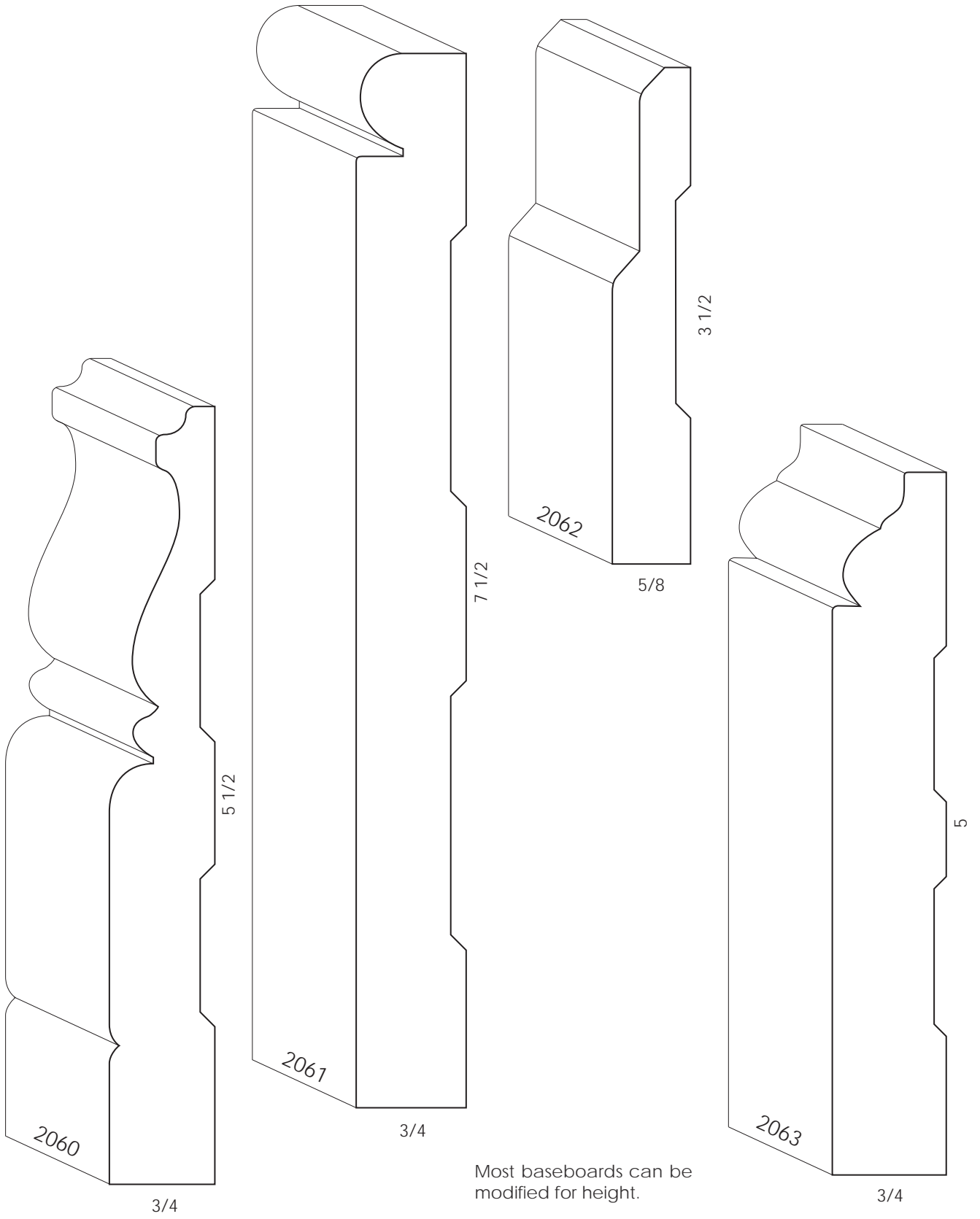

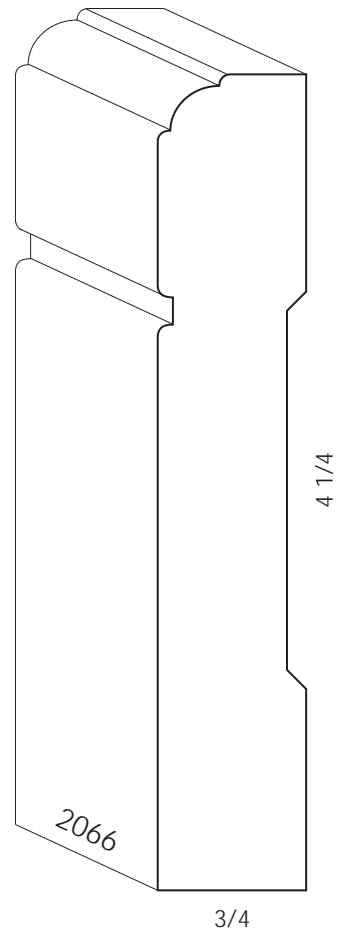
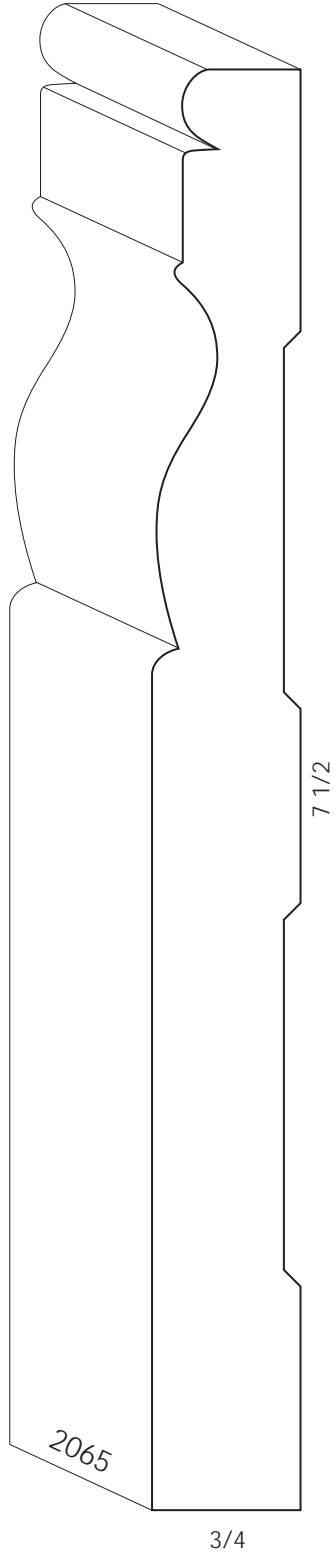
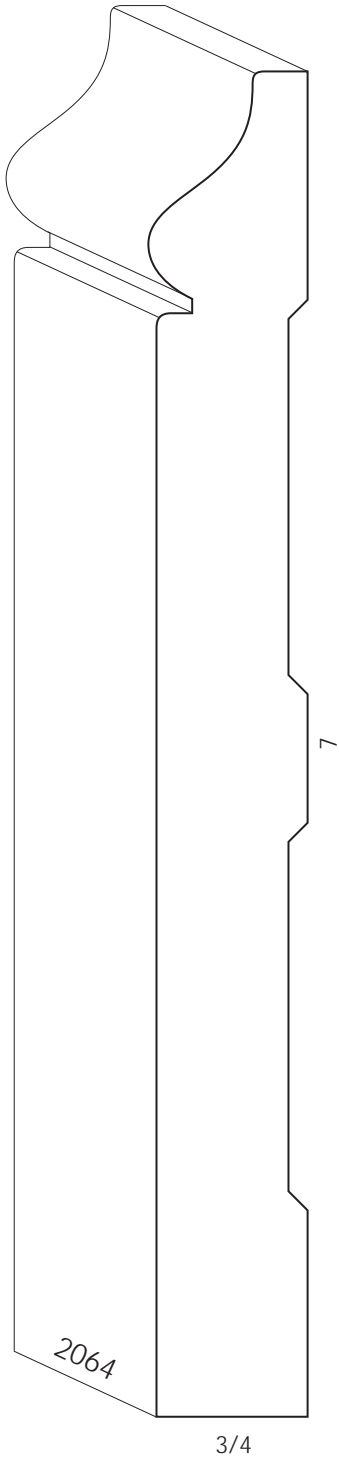

Base

Most baseboards can be modified for height.

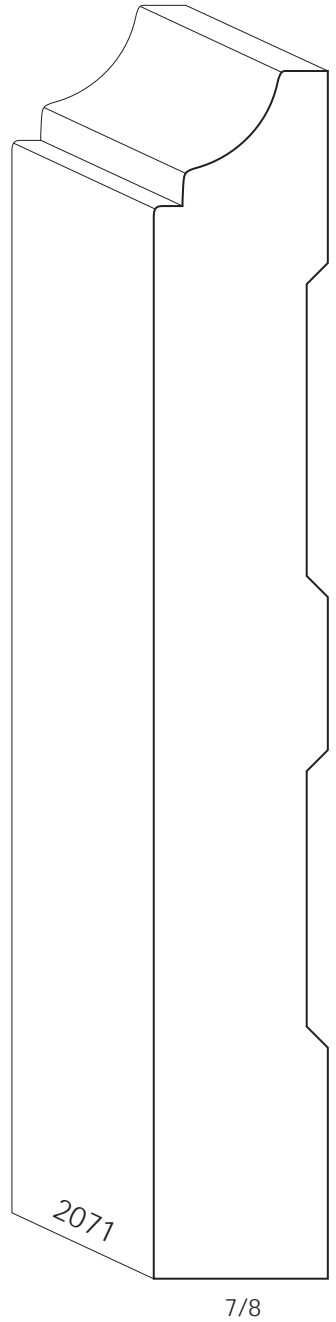
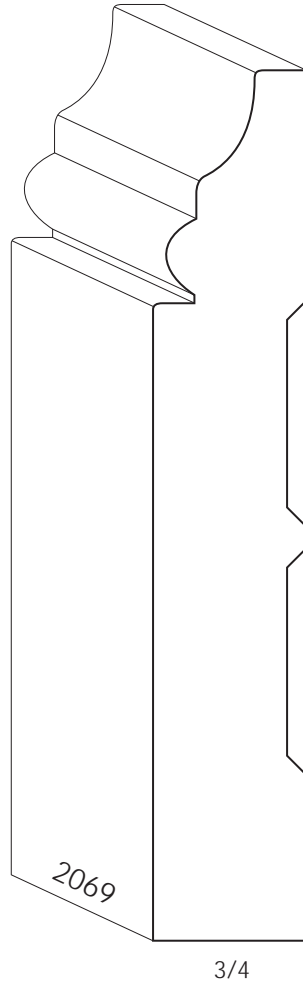
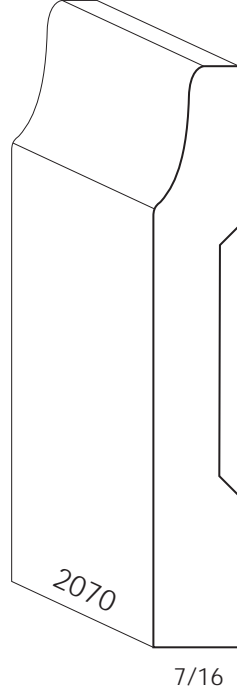
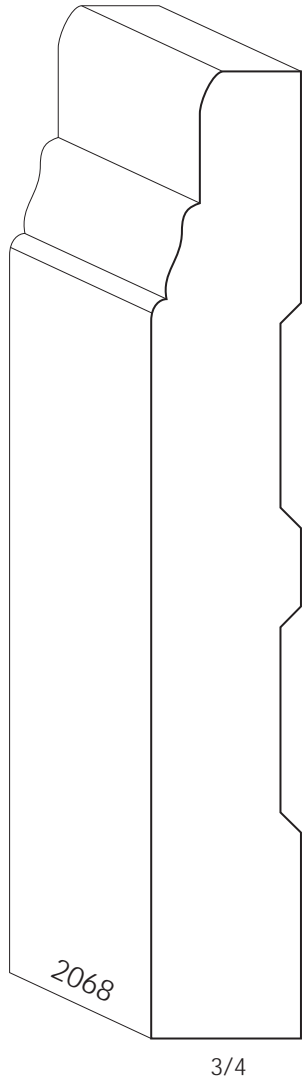
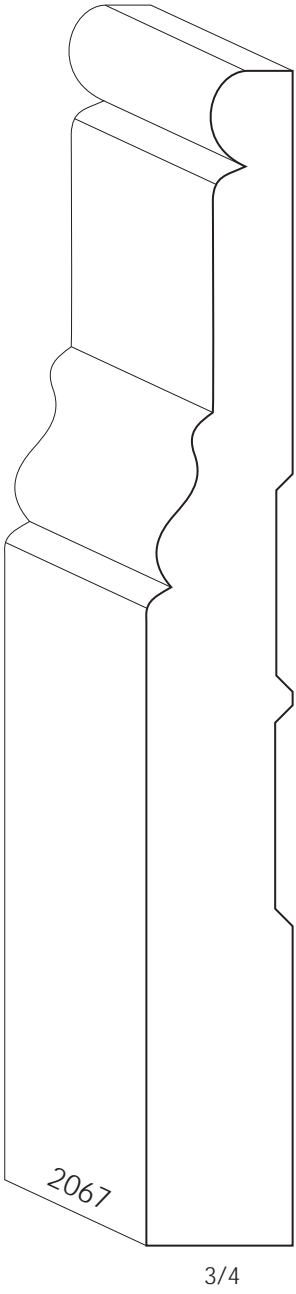

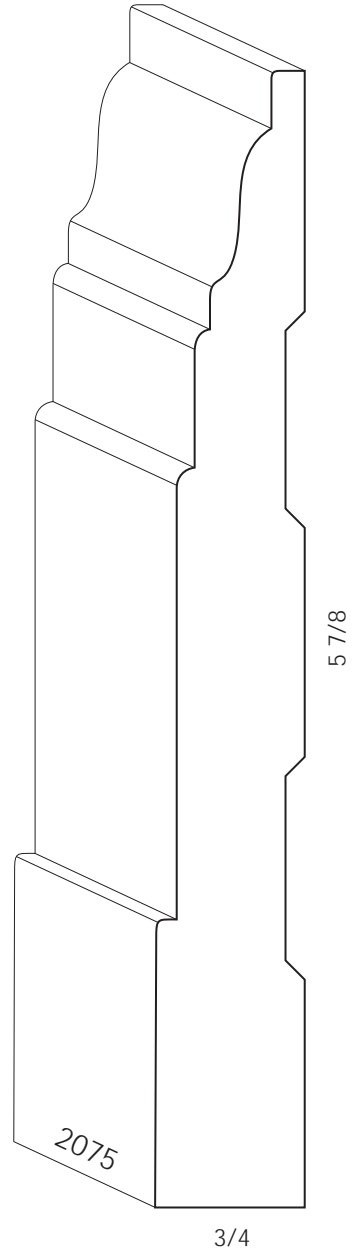
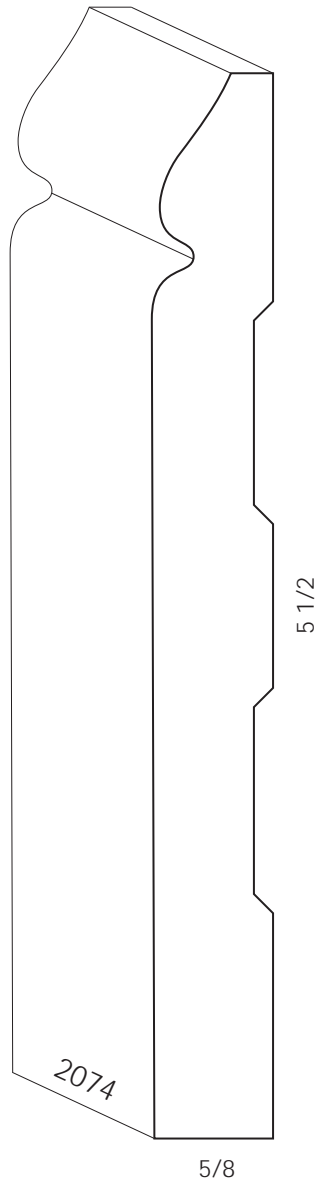
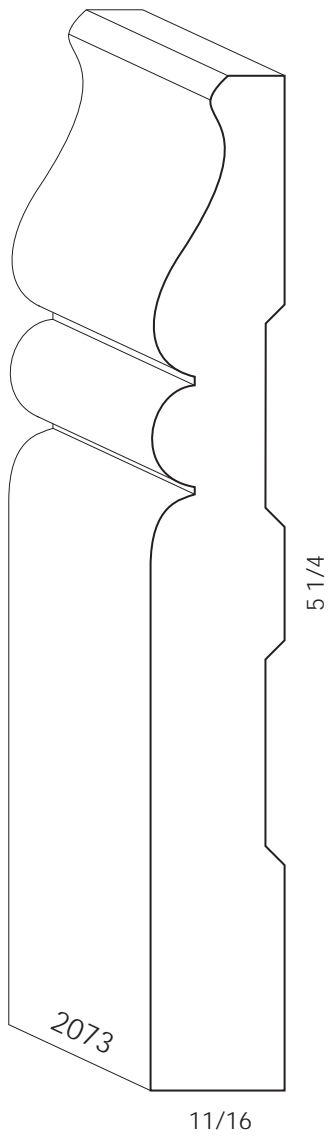
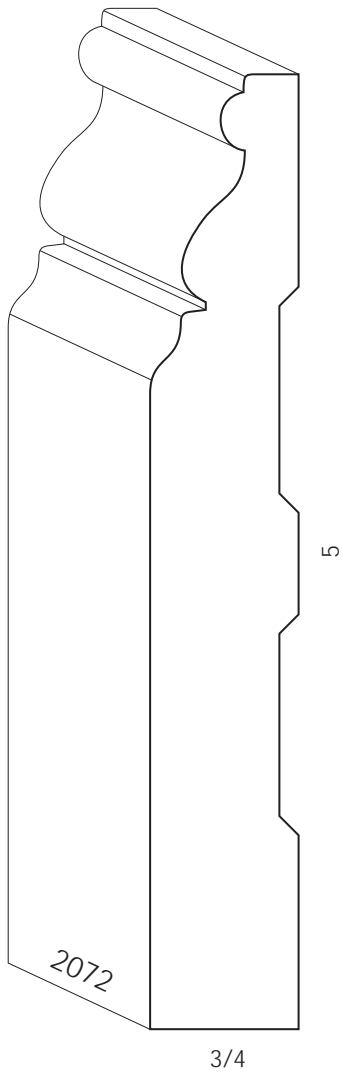

Base

Base

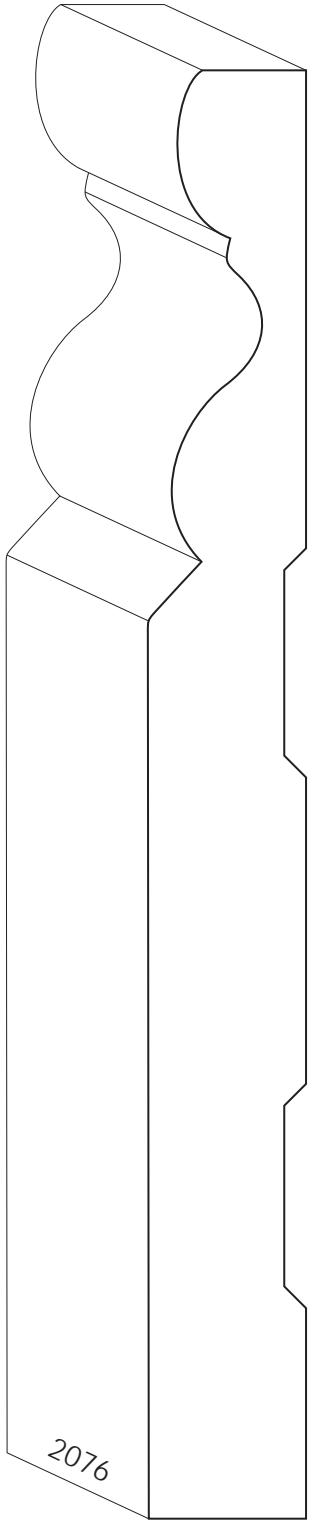

2076

13/16

7 1/2

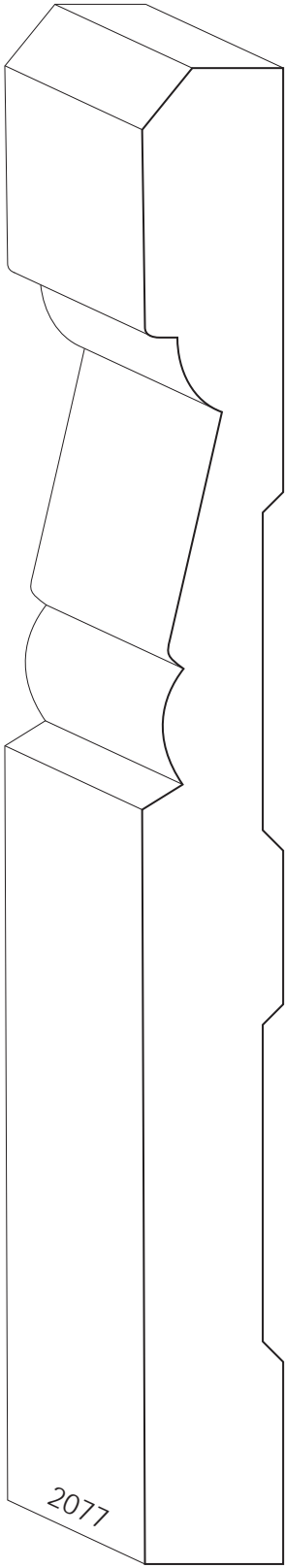

2077

3/4

8

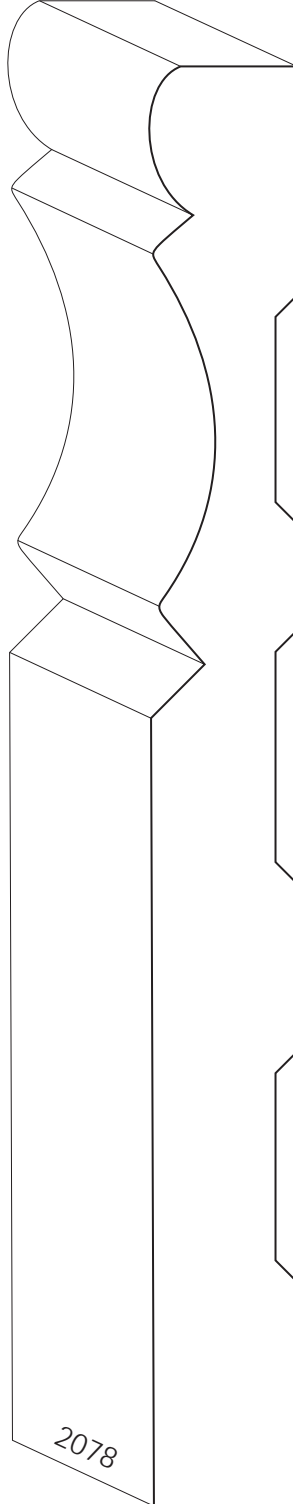

2078

3/4

7 1/2

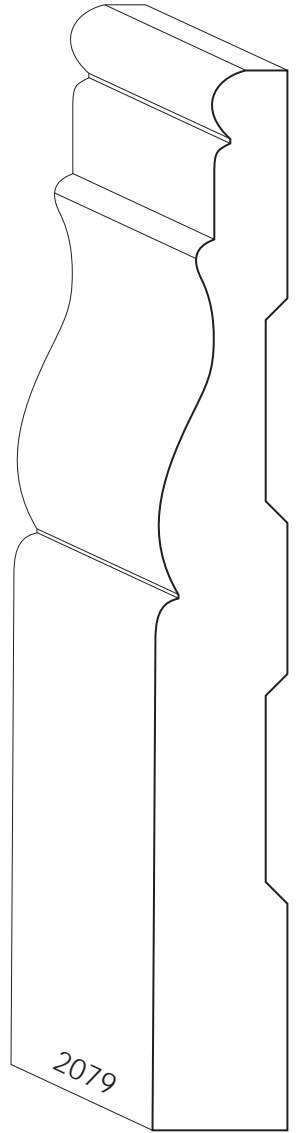

2079

11/16

5 1/2

Most baseboards can be modified for height.

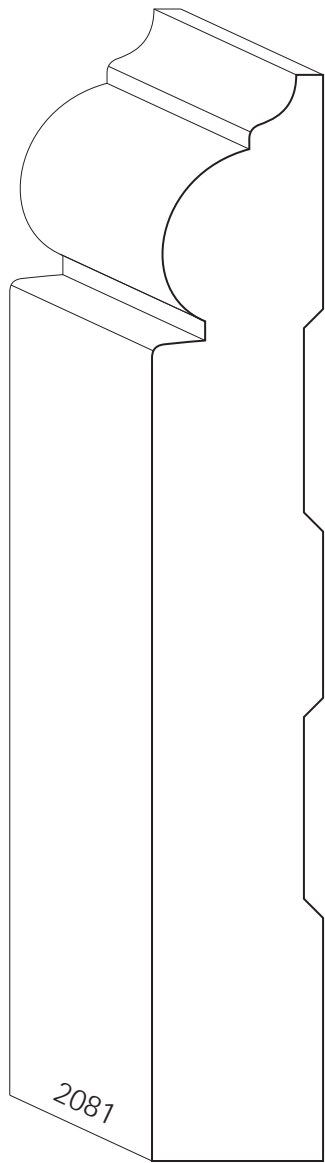

2081

7/8

5 3/4

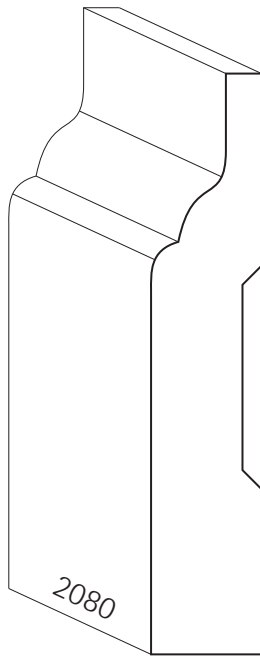

2080

7/16

3

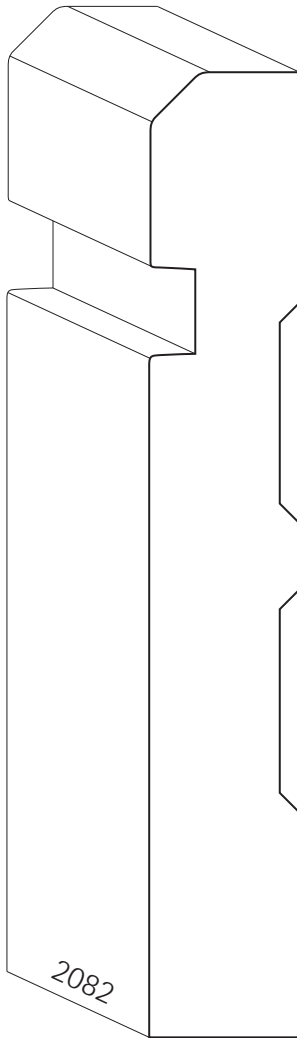

2082

3/4

5

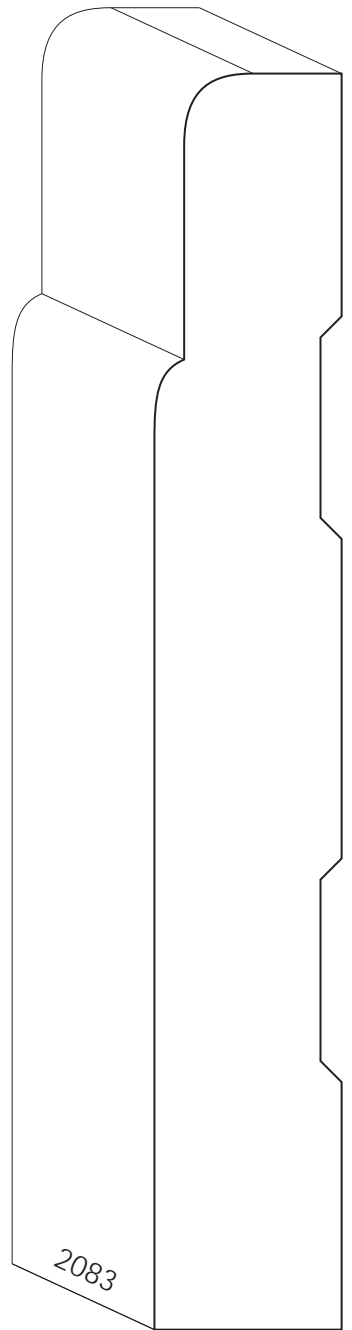

2083

15/16

6 1/2

Base

Base

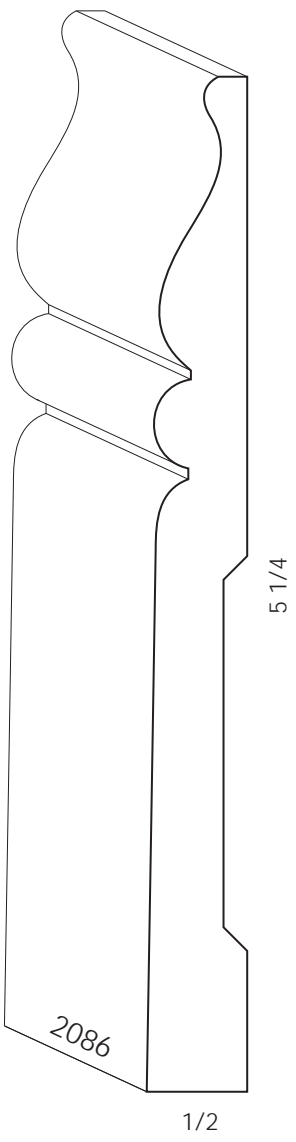
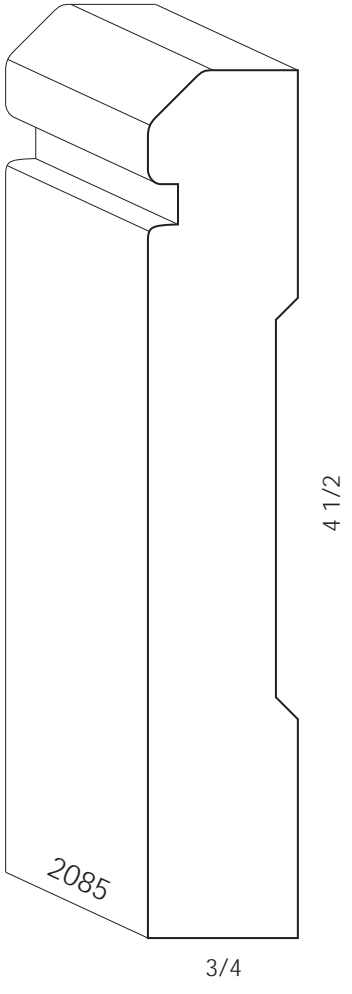
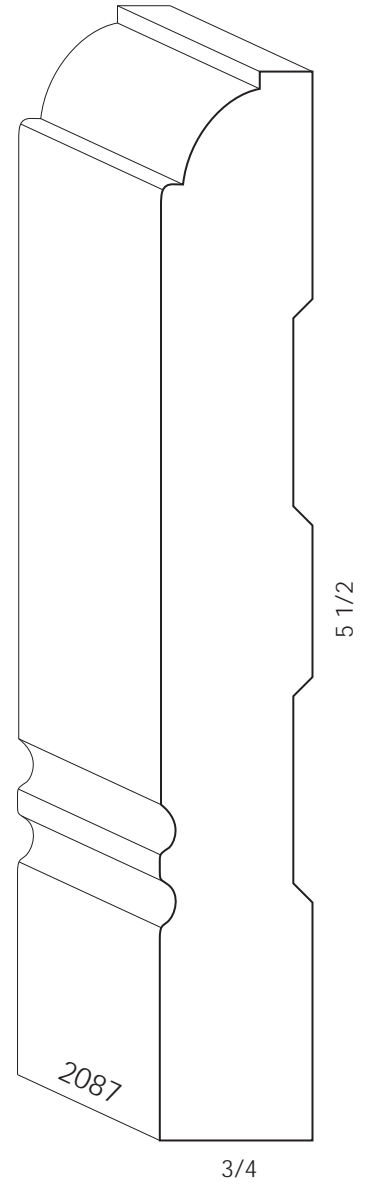
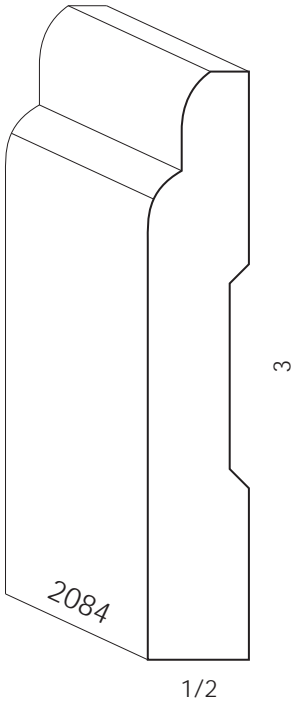

Most baseboards can be modified for height.

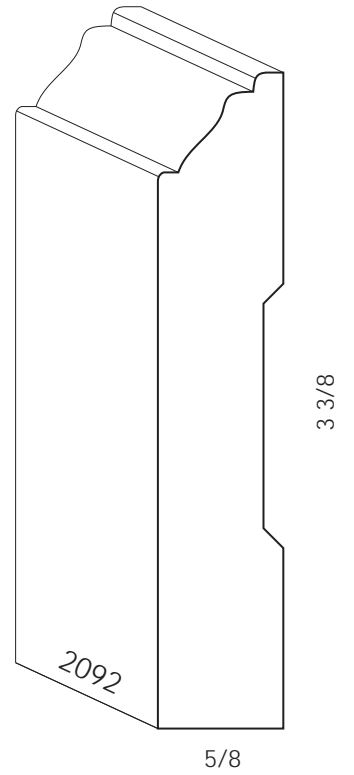
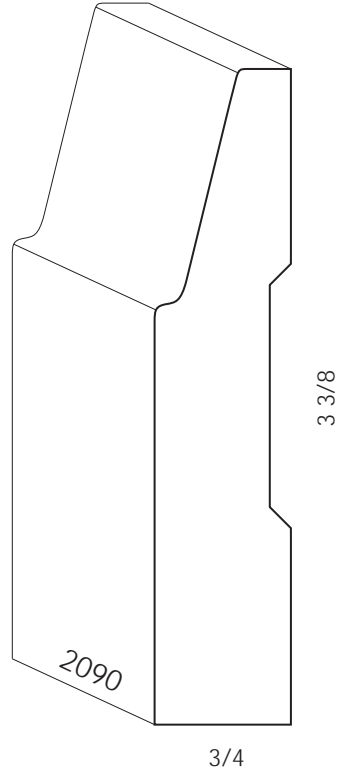
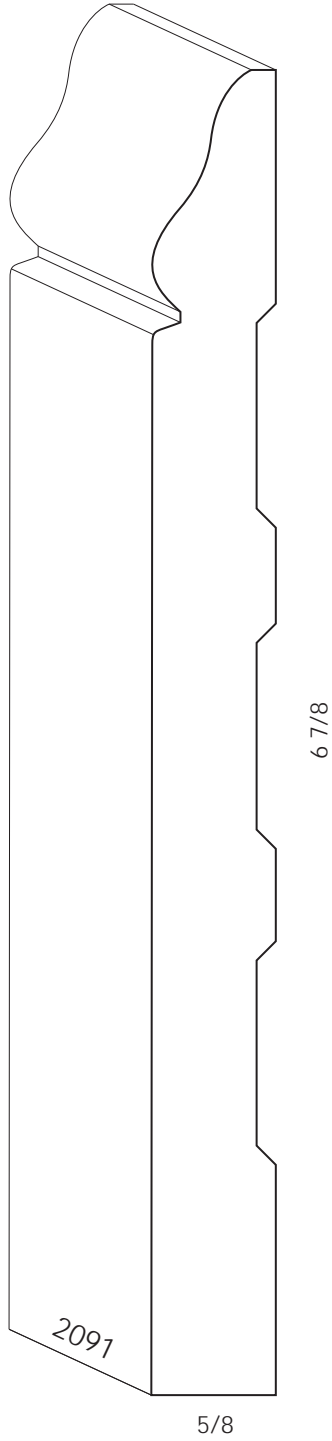
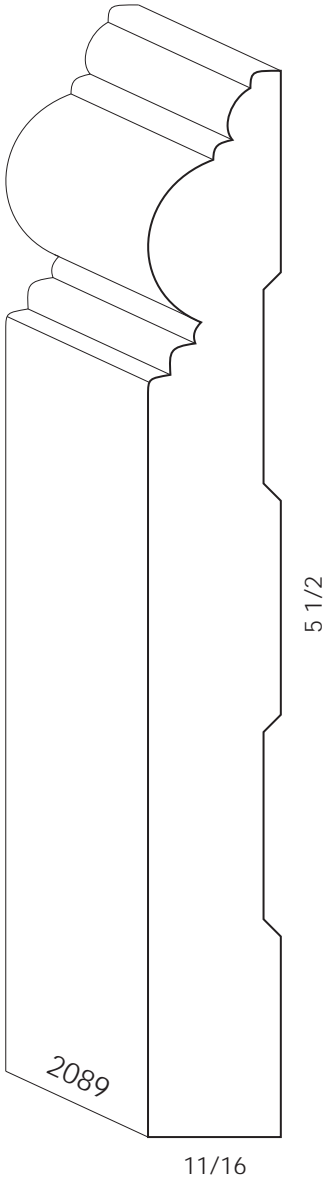
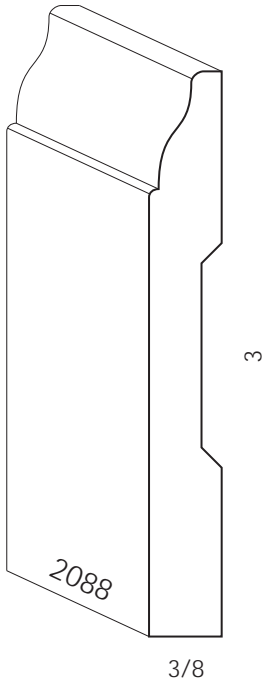

Base

Crown

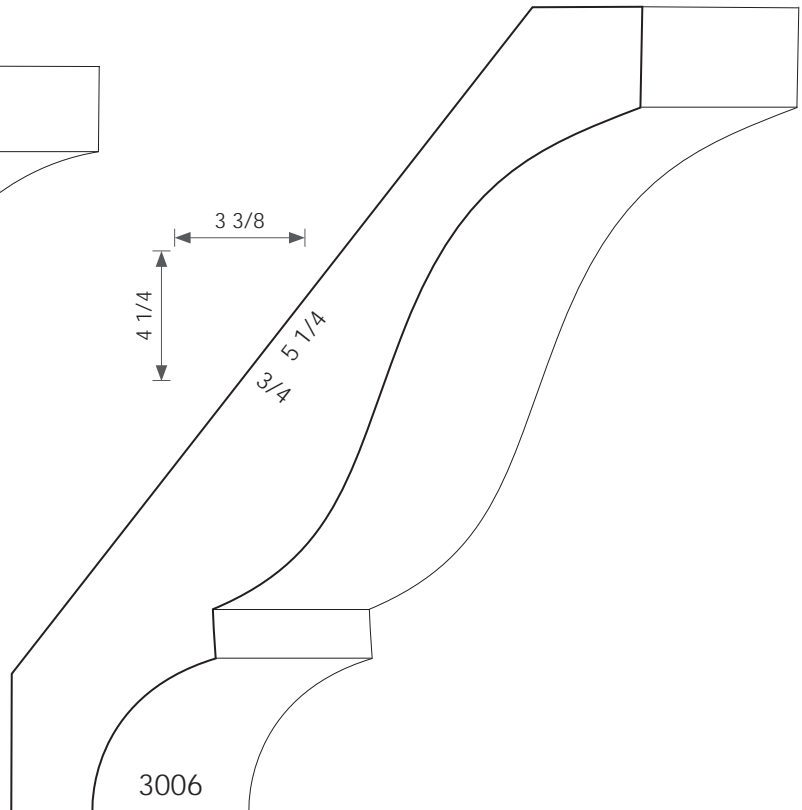
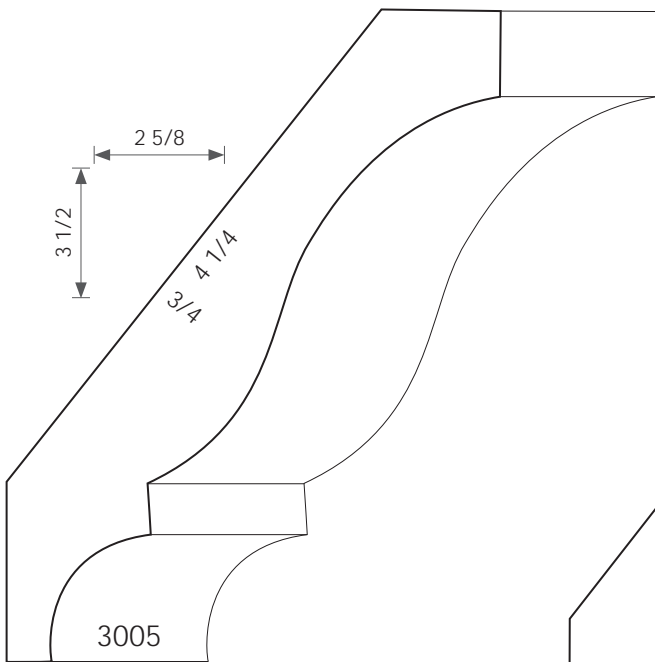
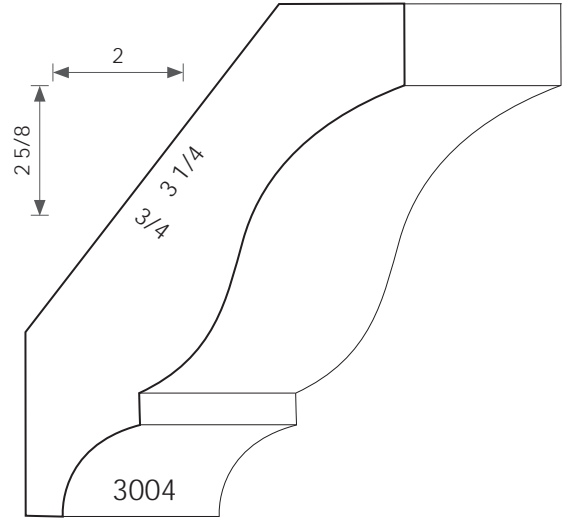
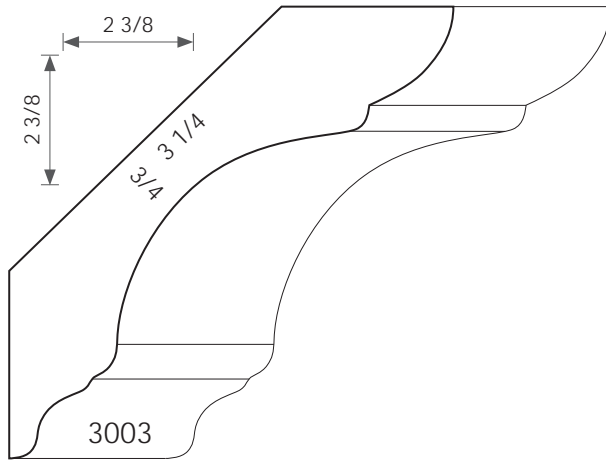
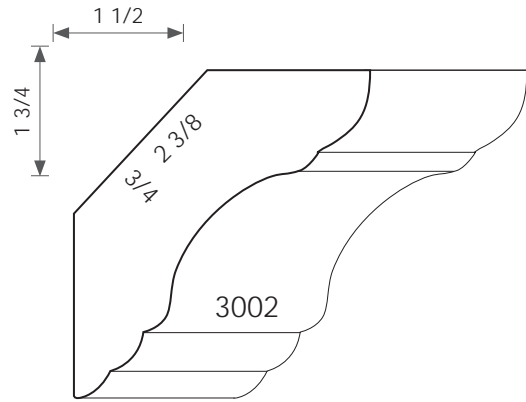
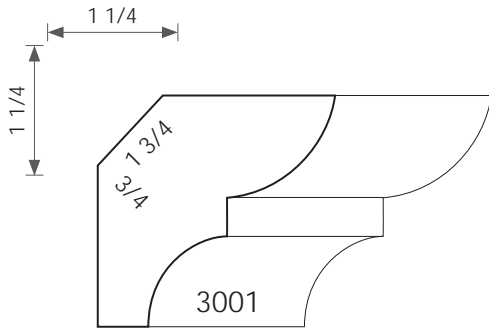

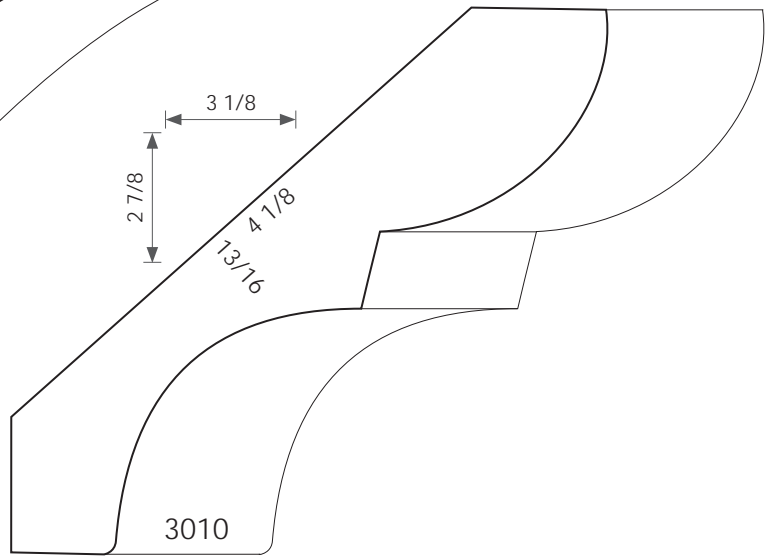
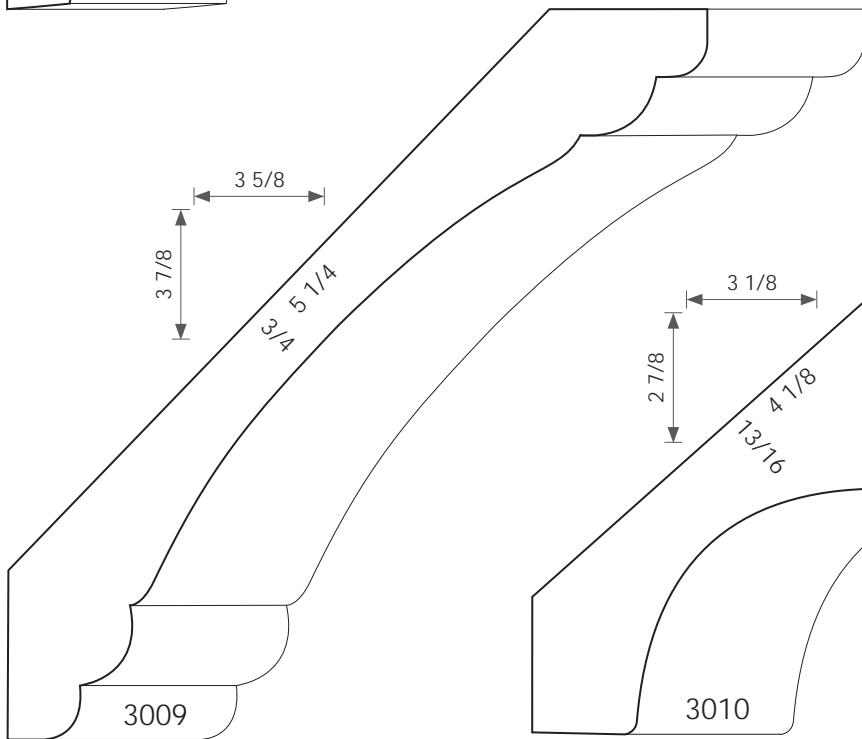
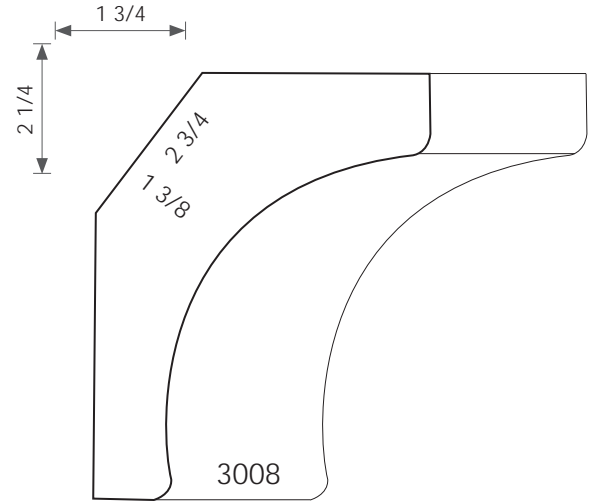
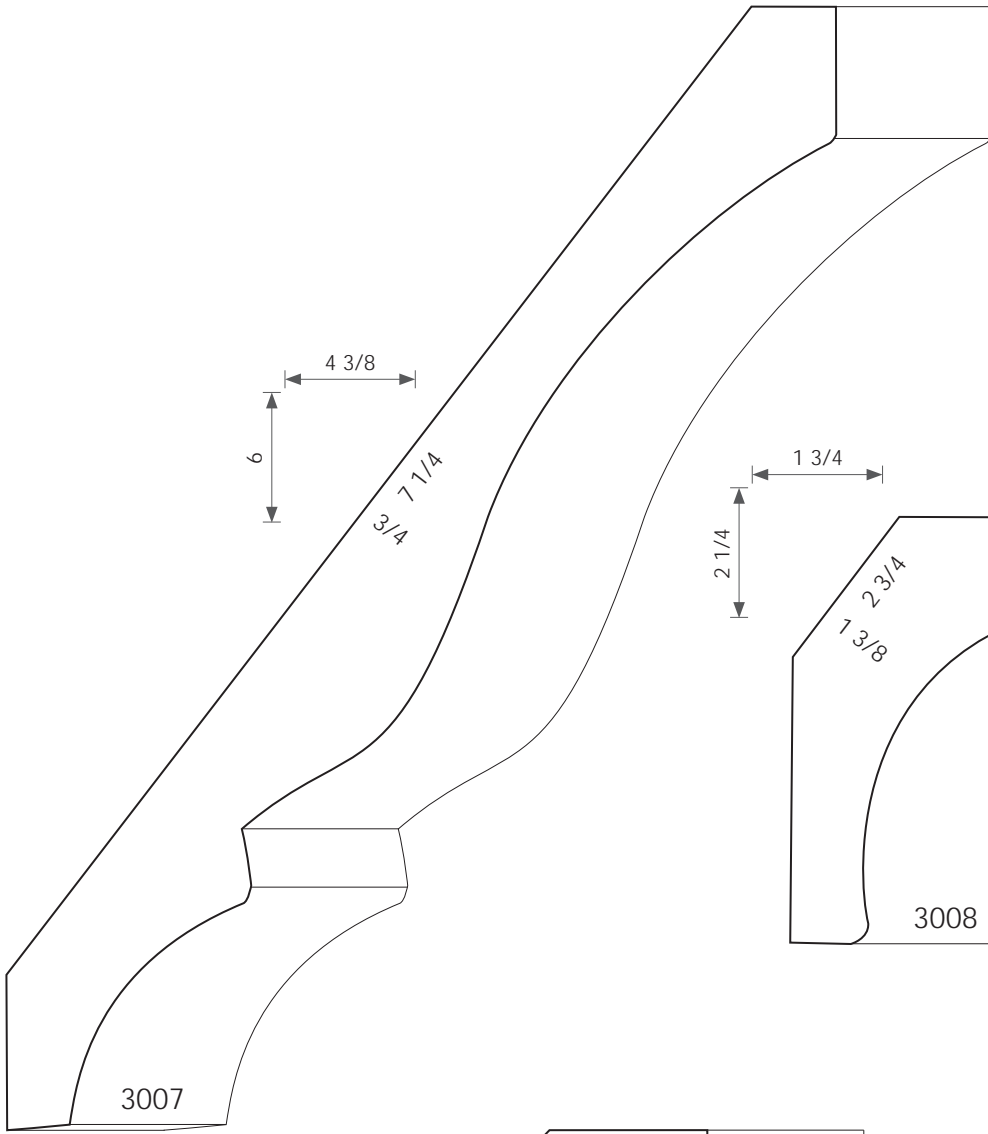

Crown

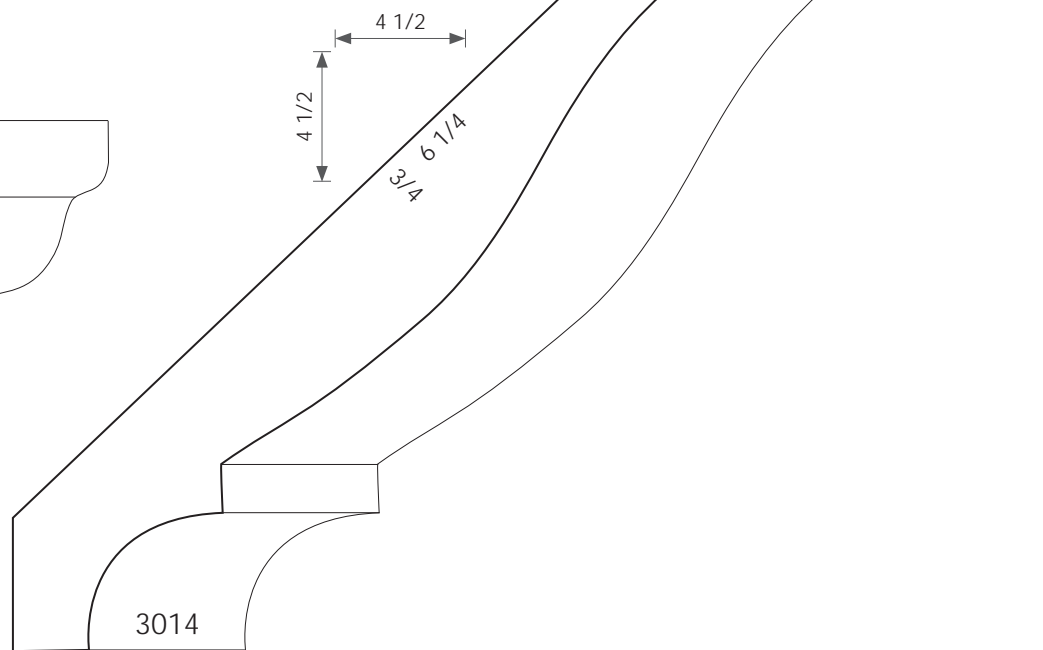
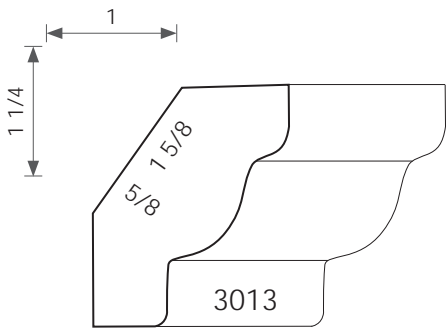
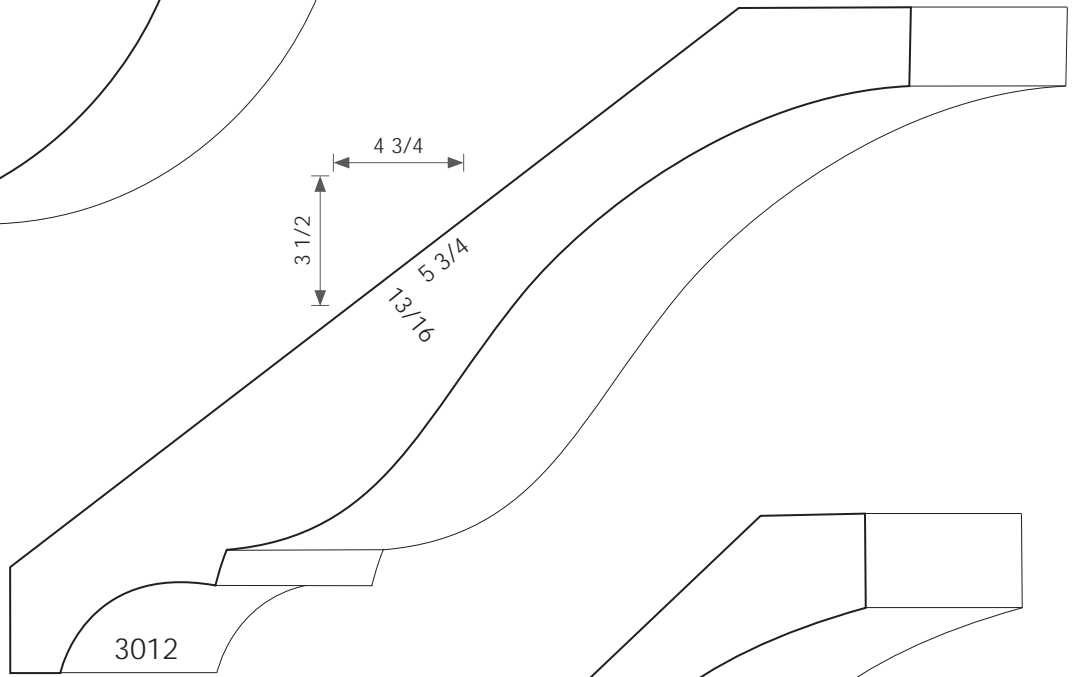
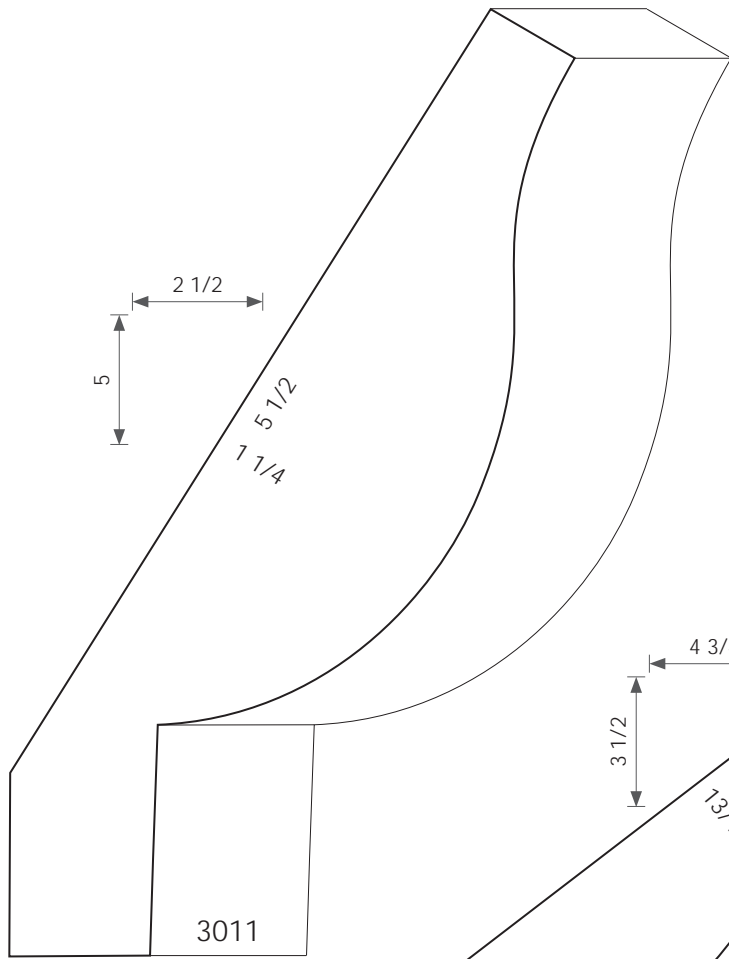

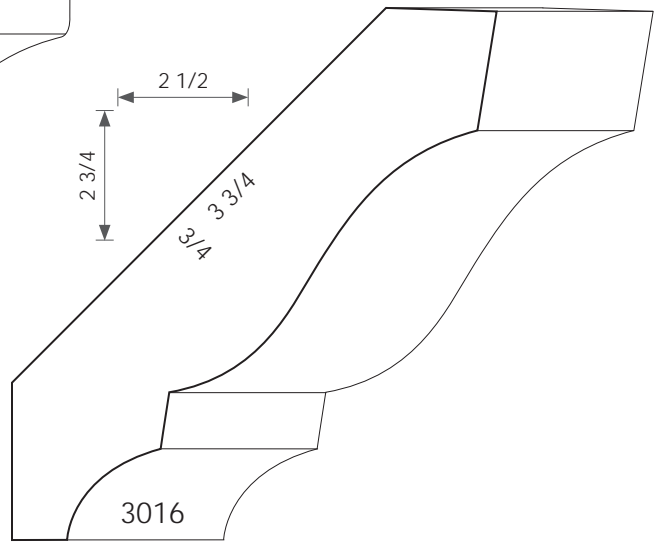
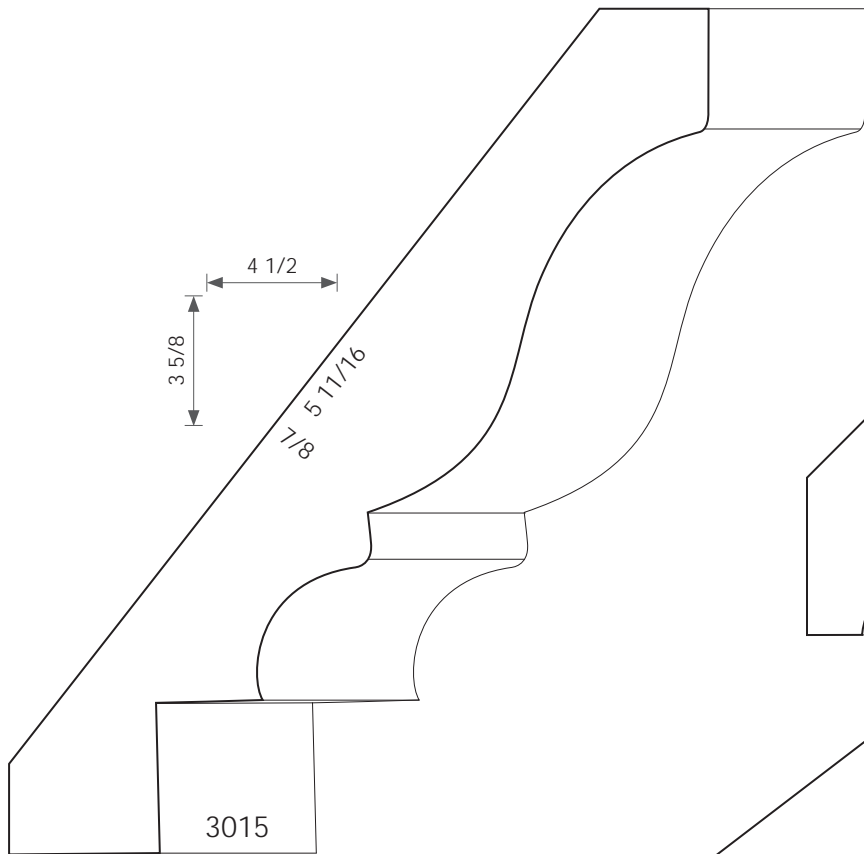

Crown

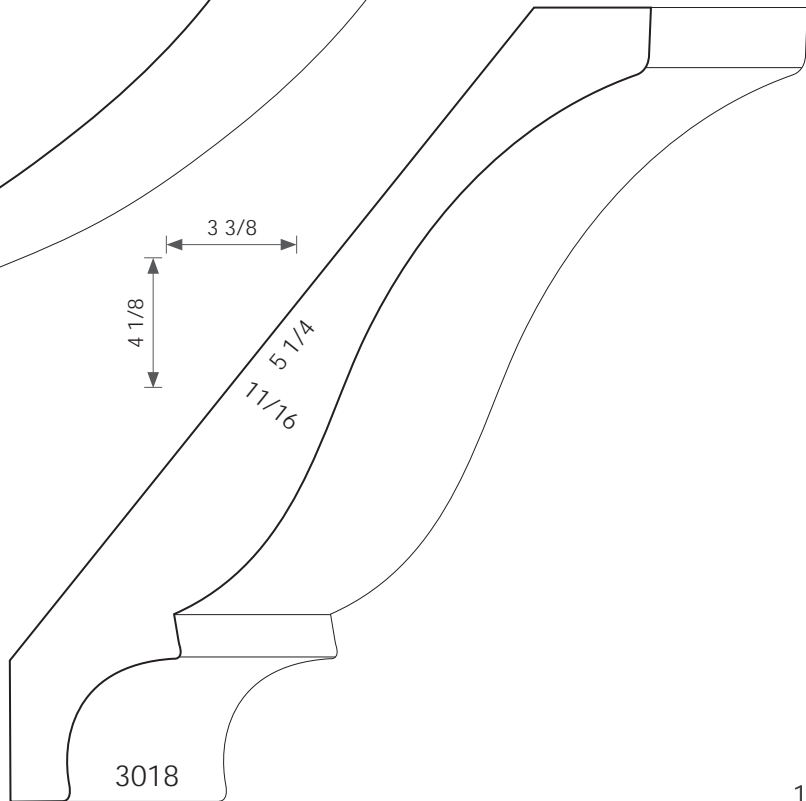
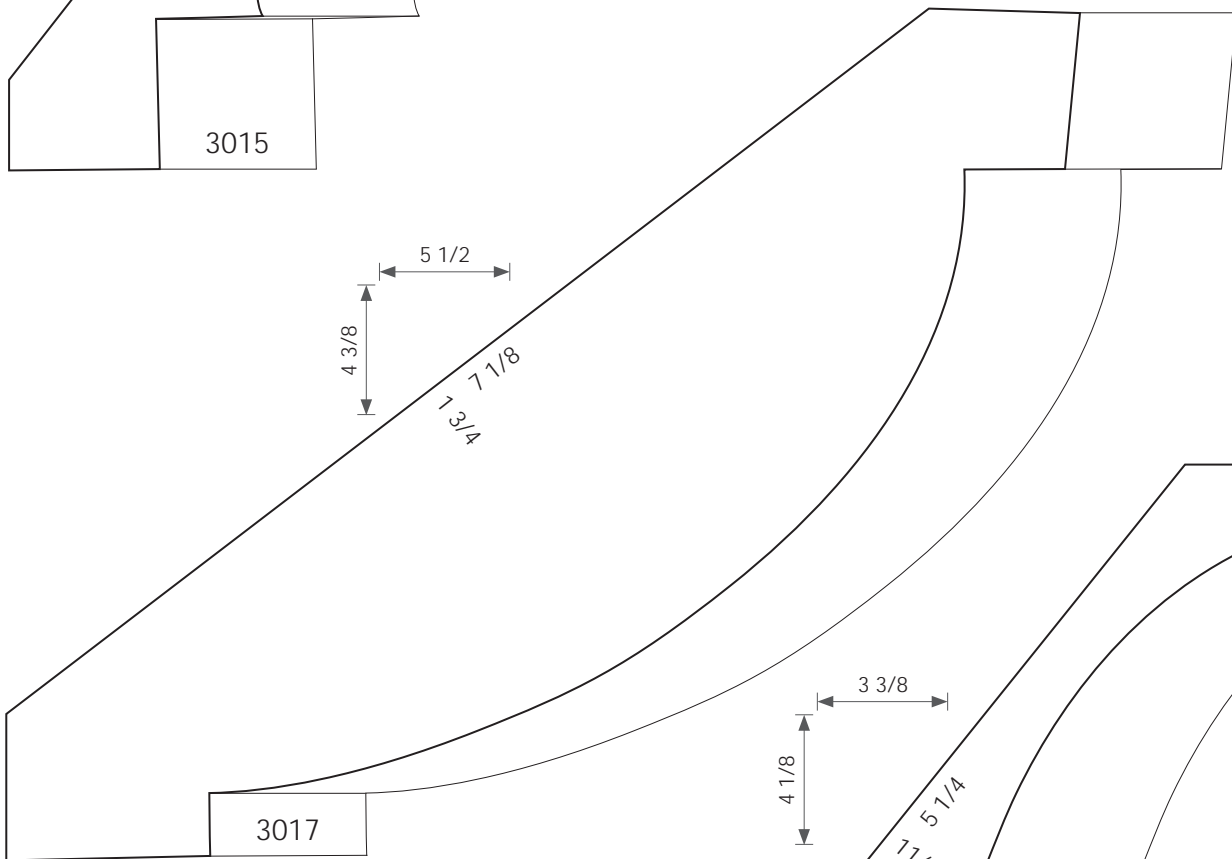

Crown

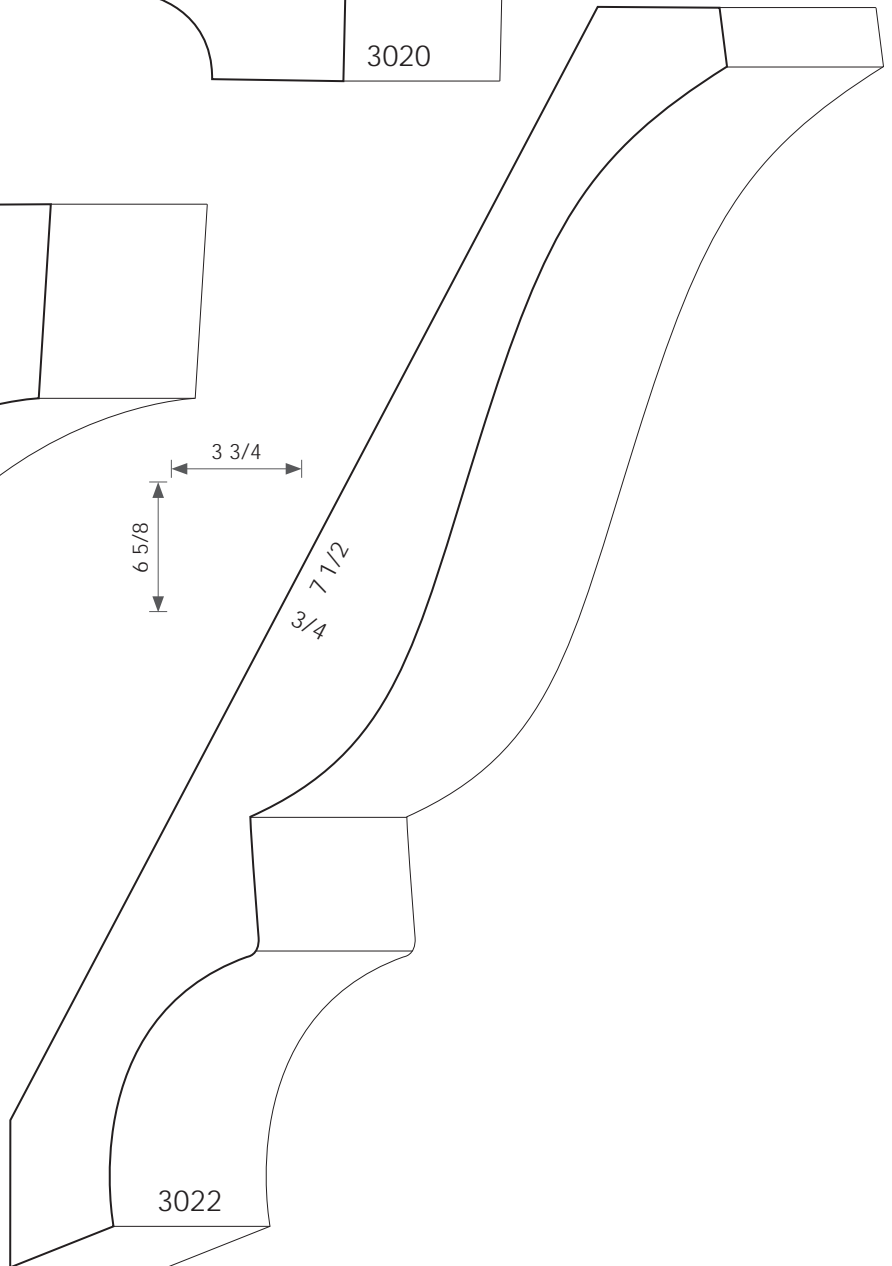
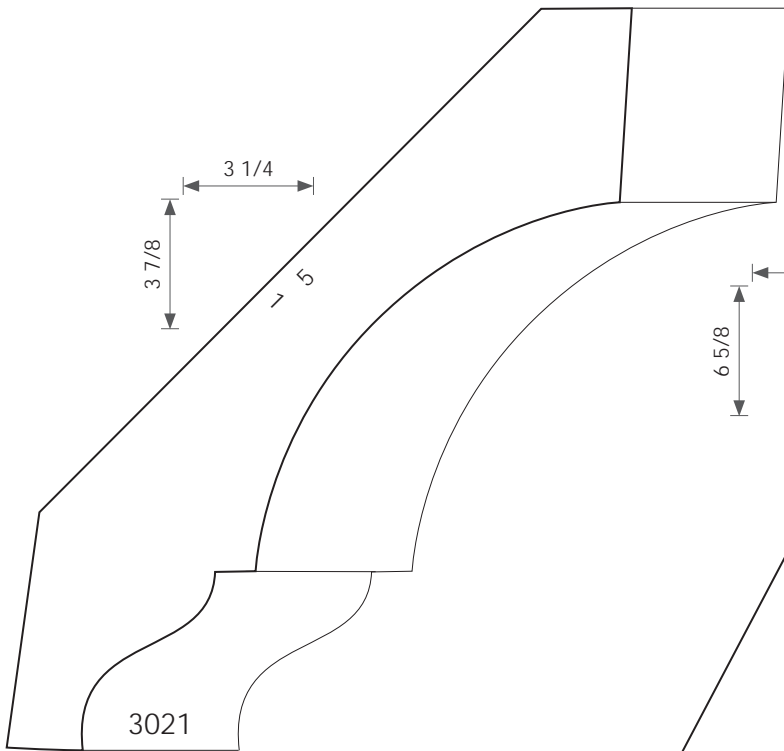
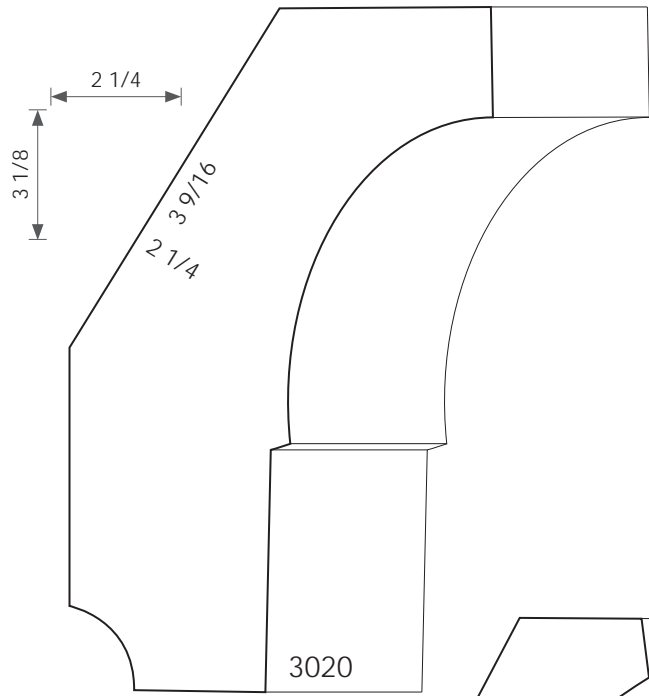
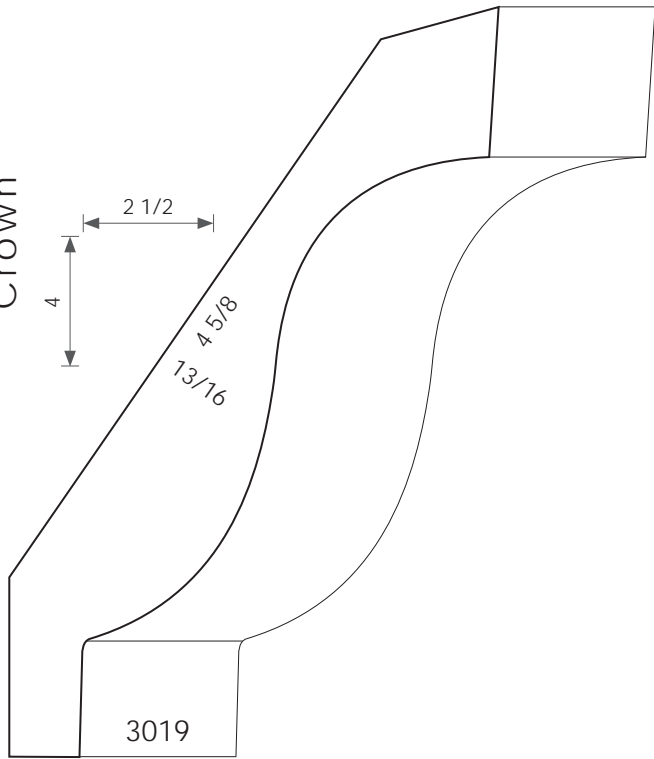

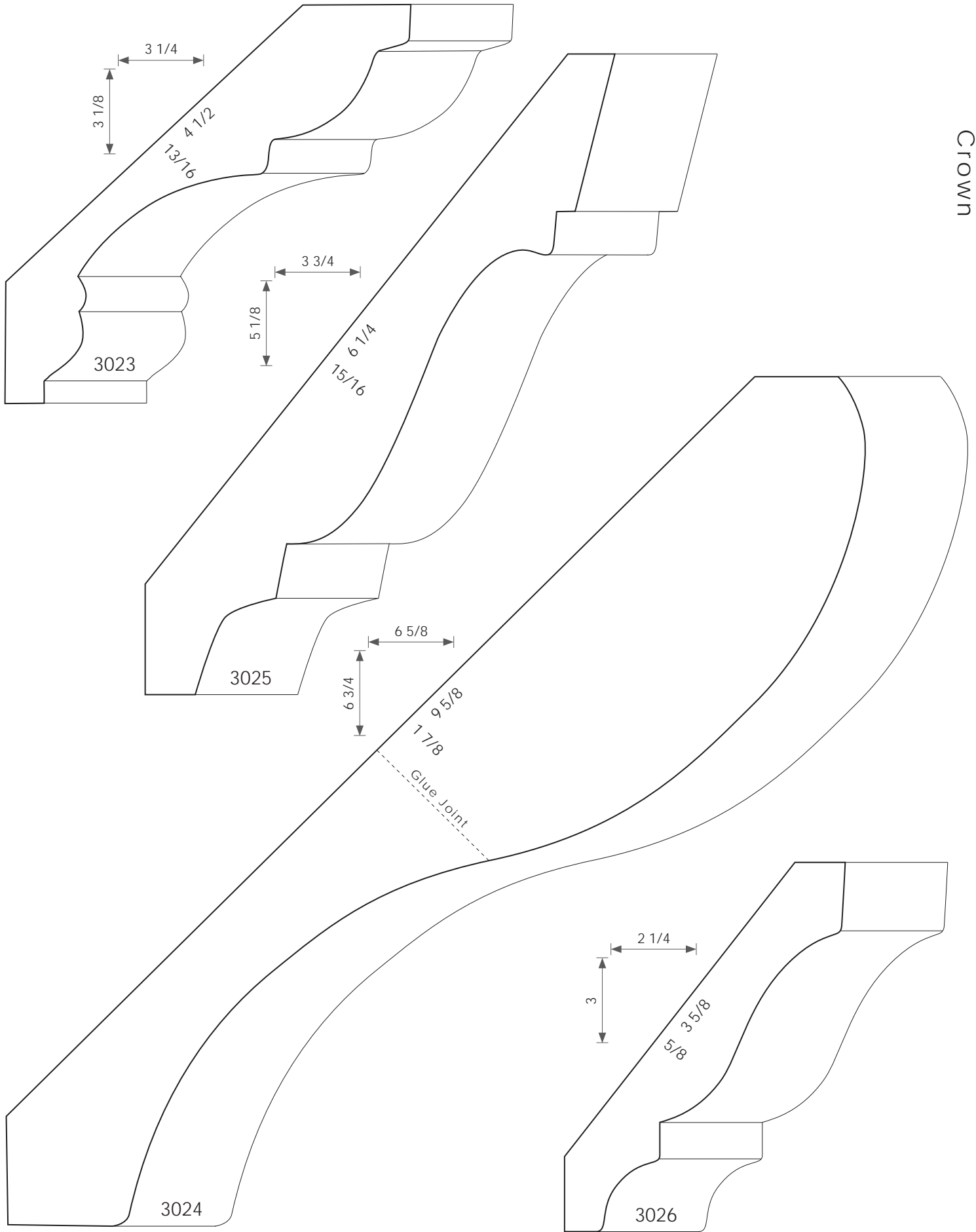

Crown

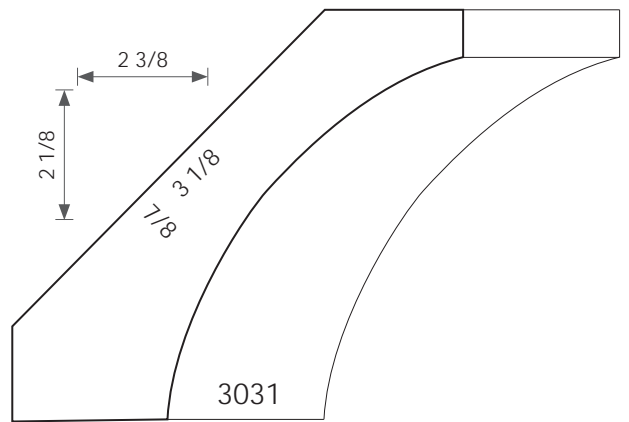
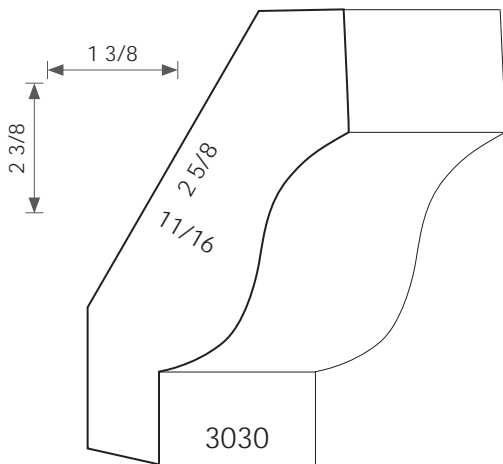
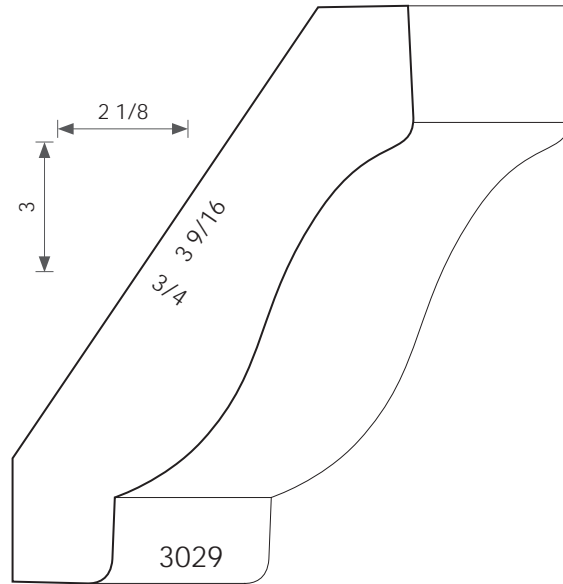
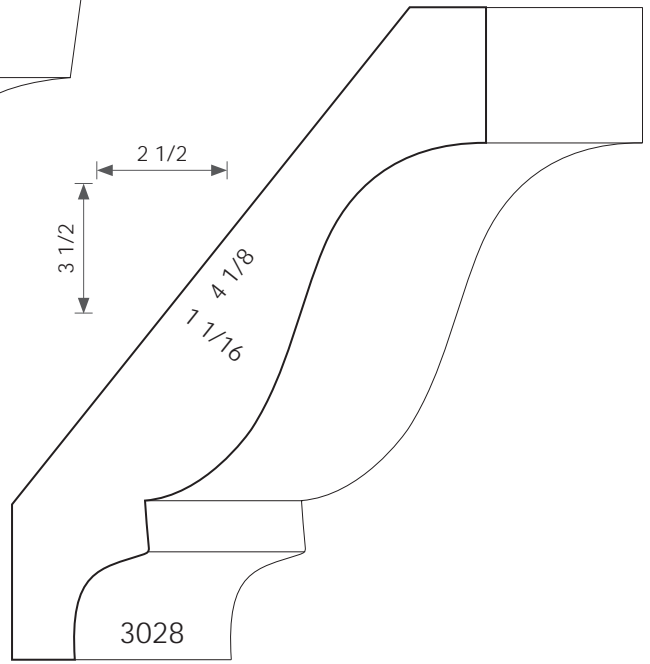
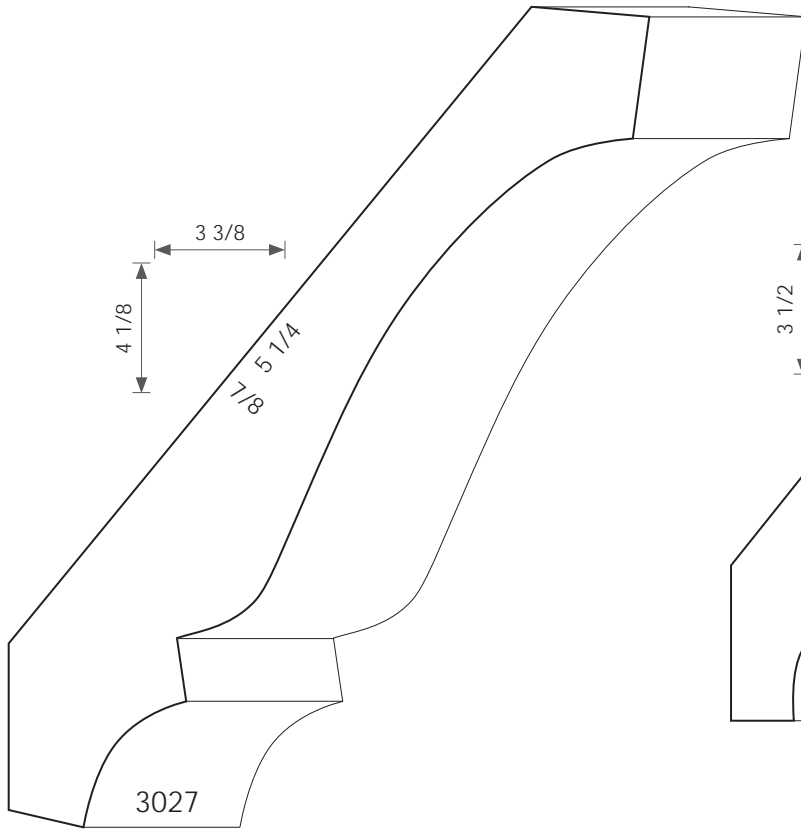

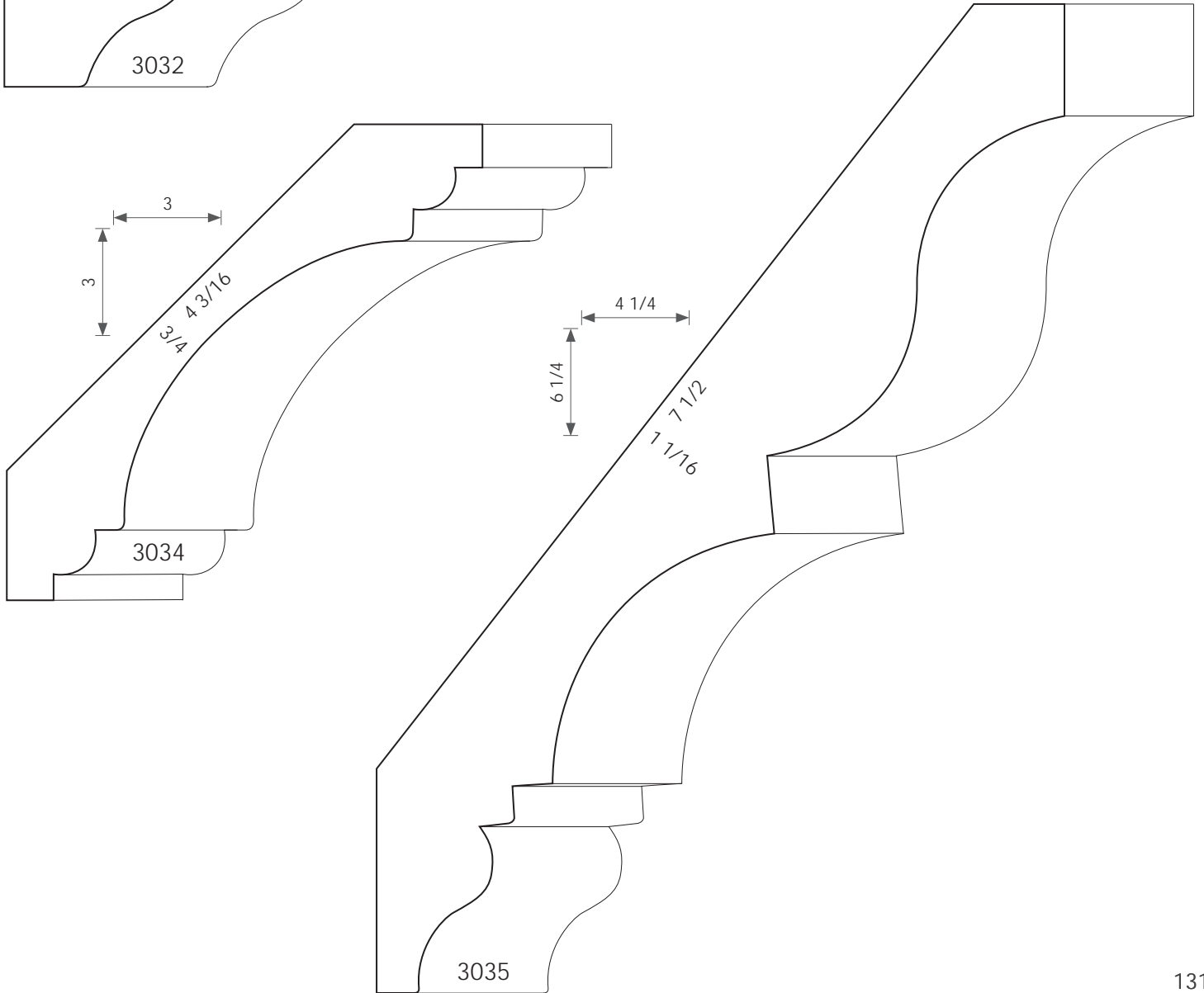
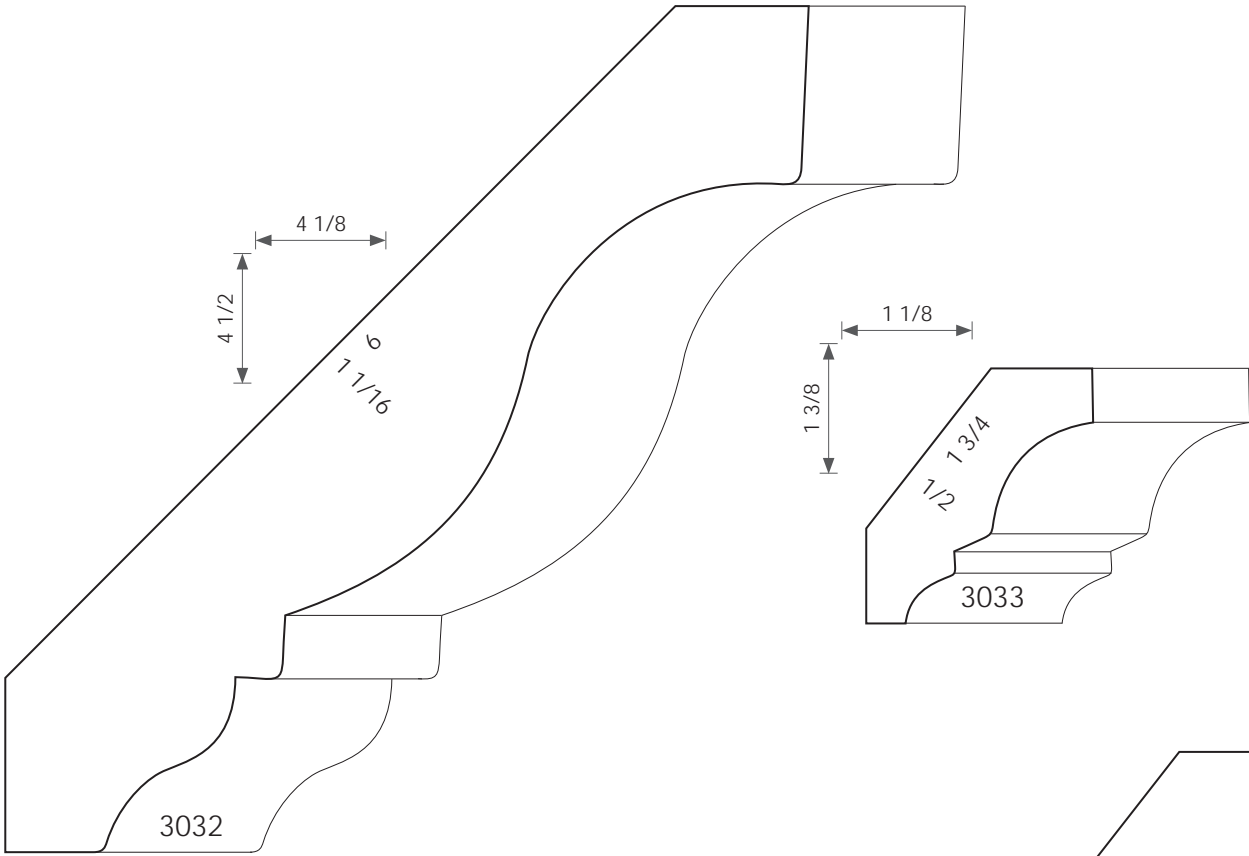

Crown

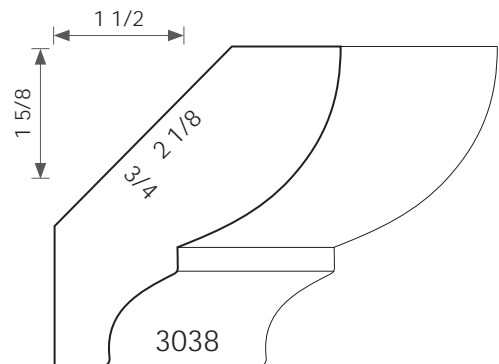
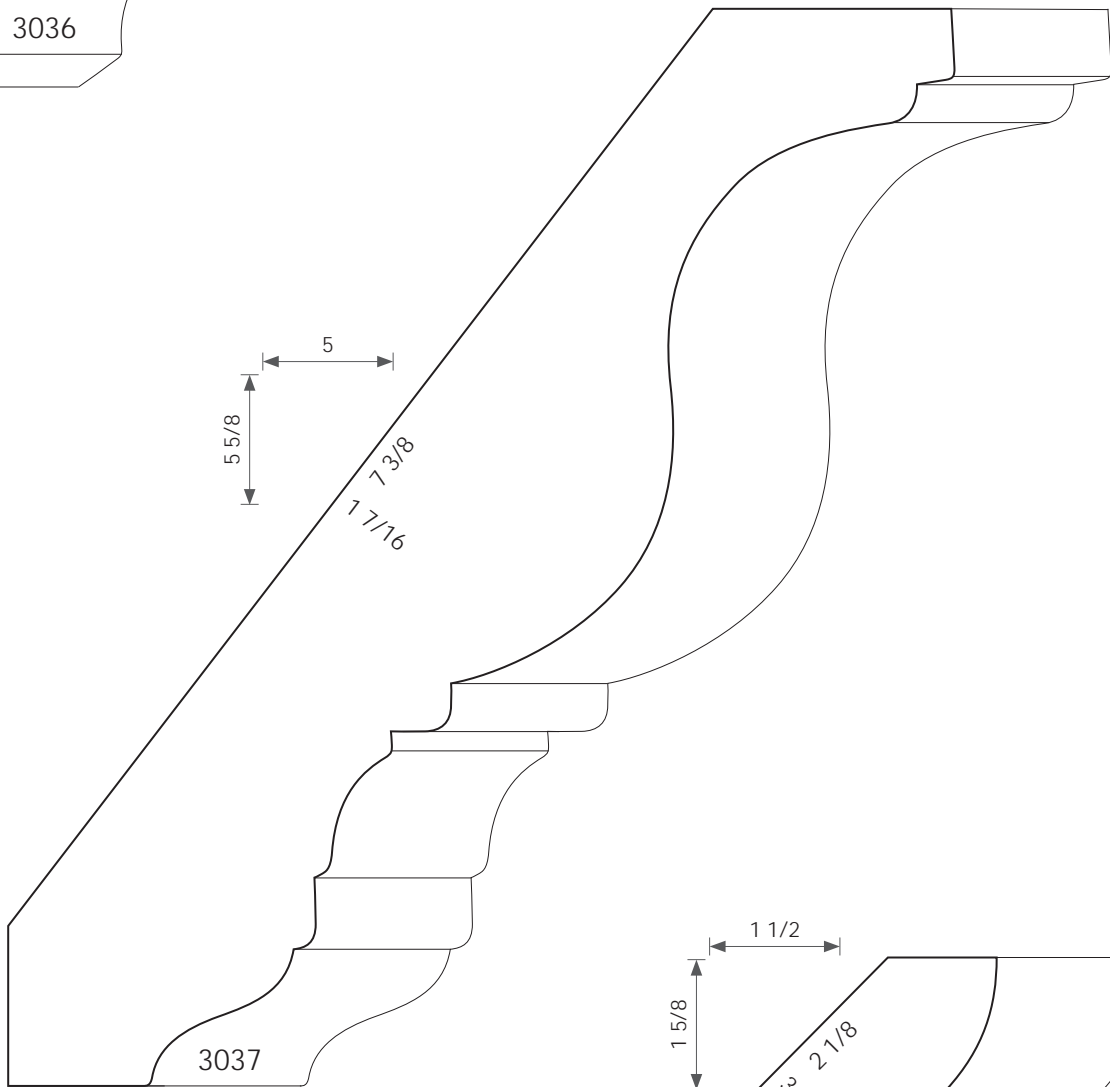
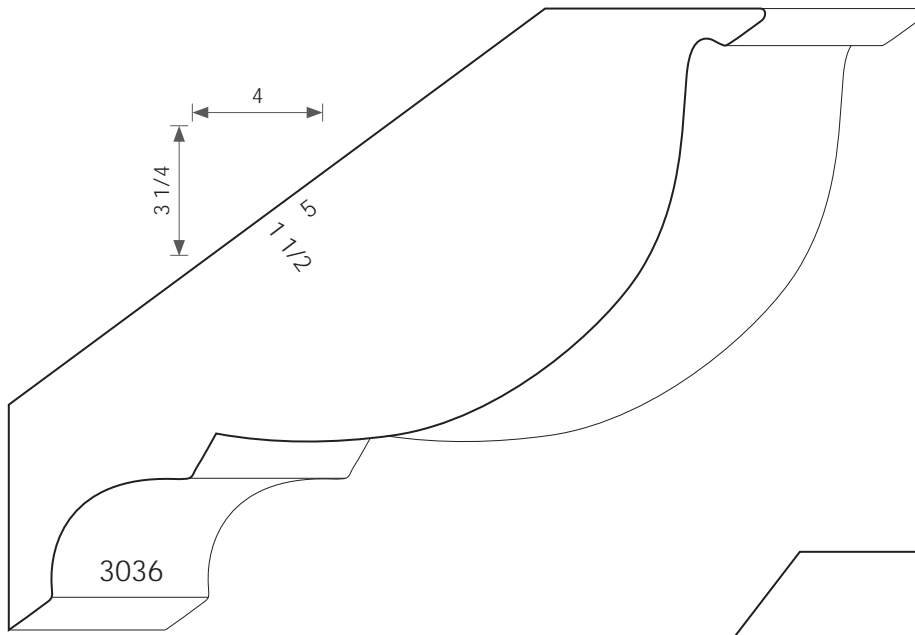

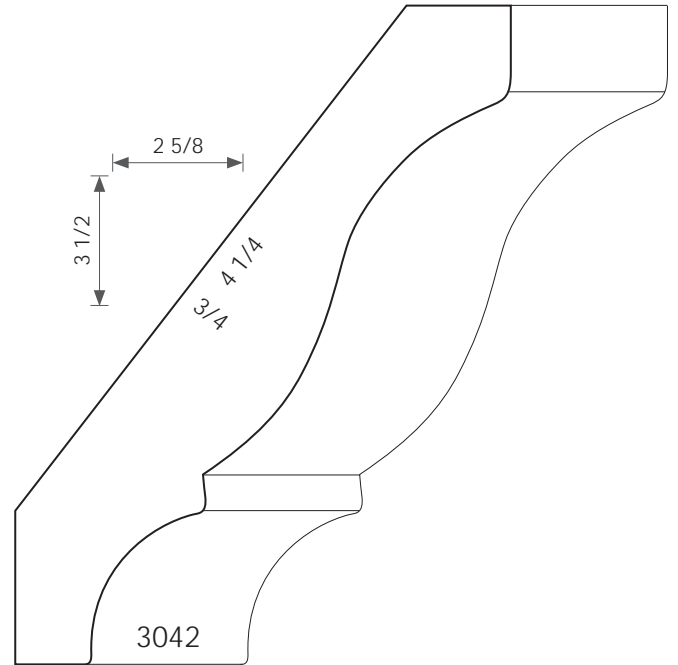
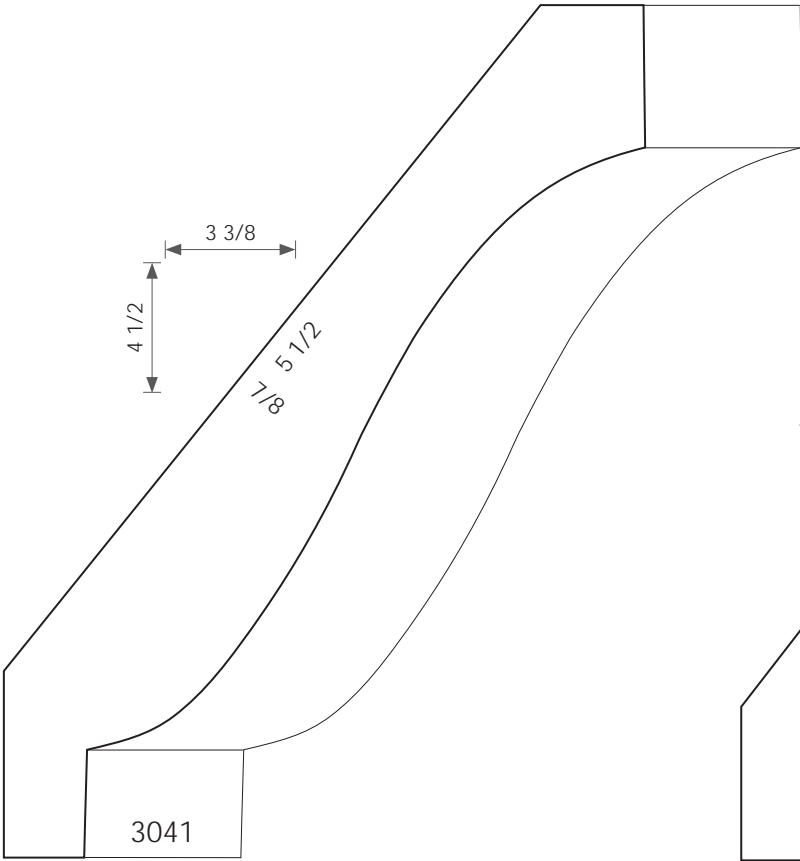
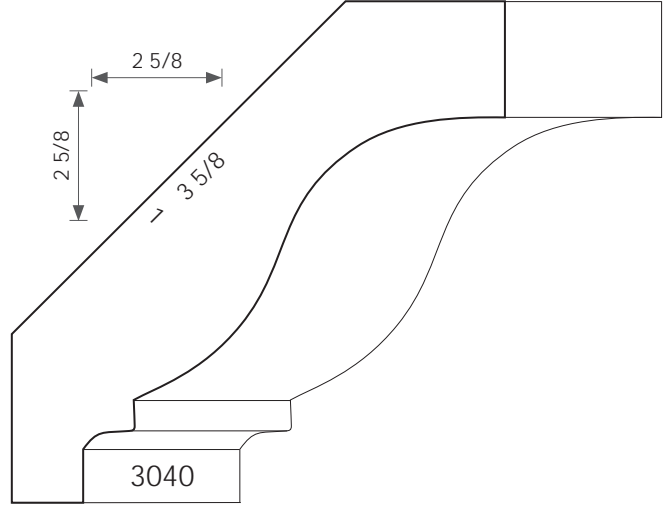
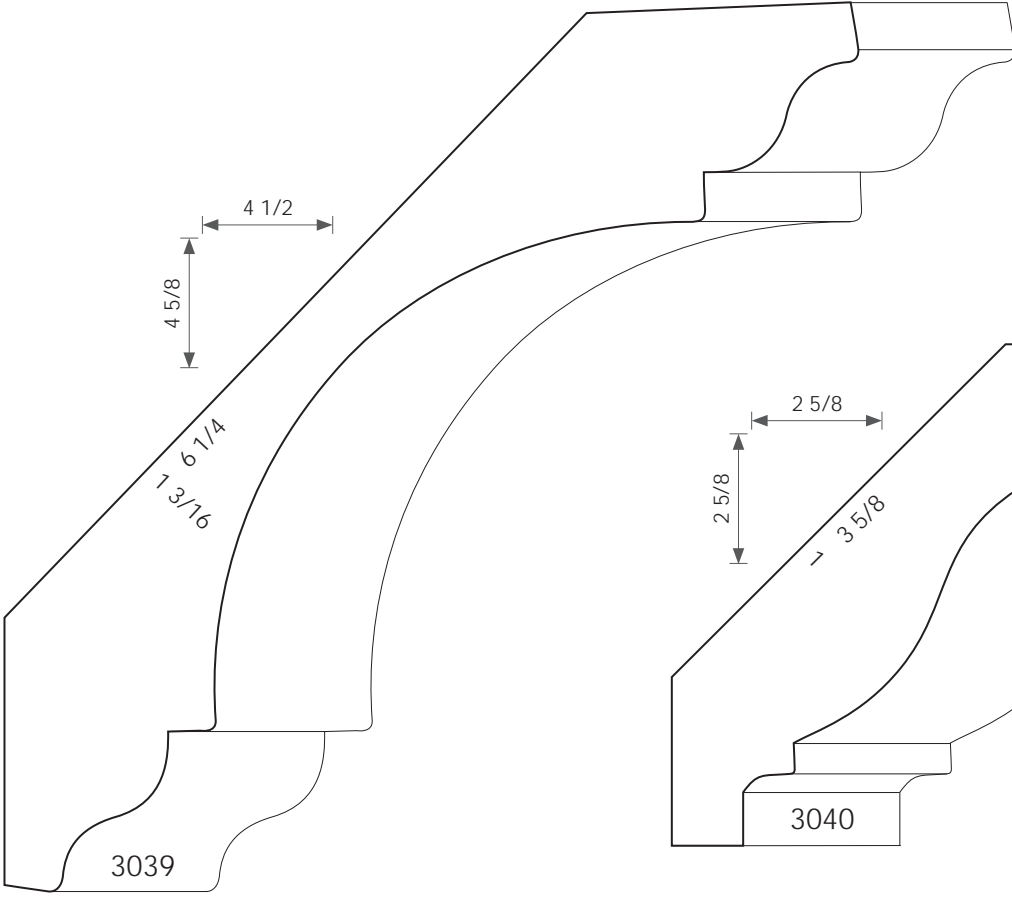

Crown

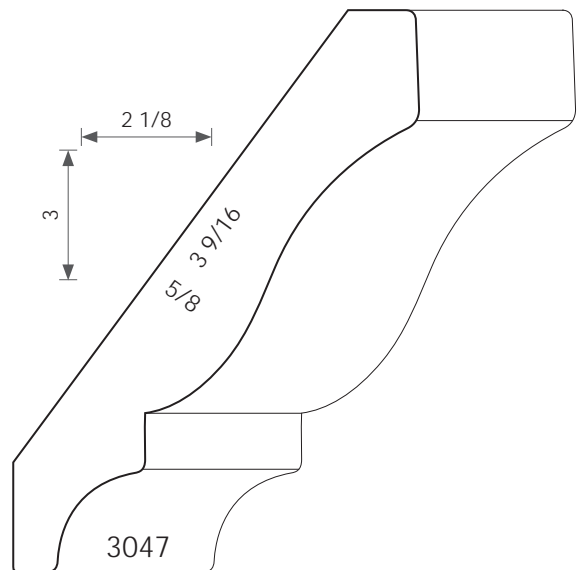
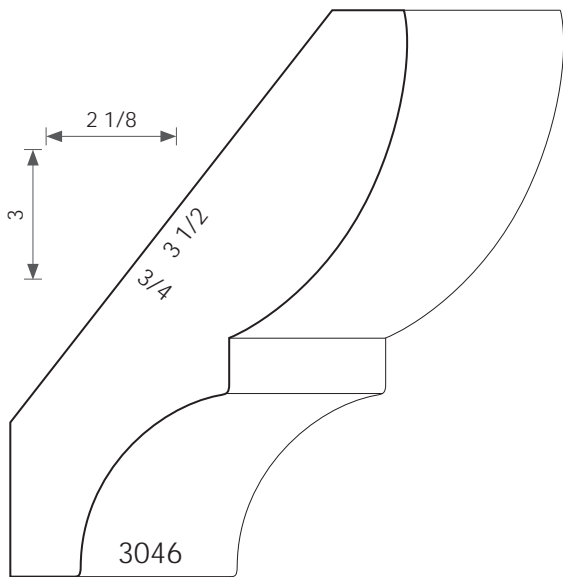
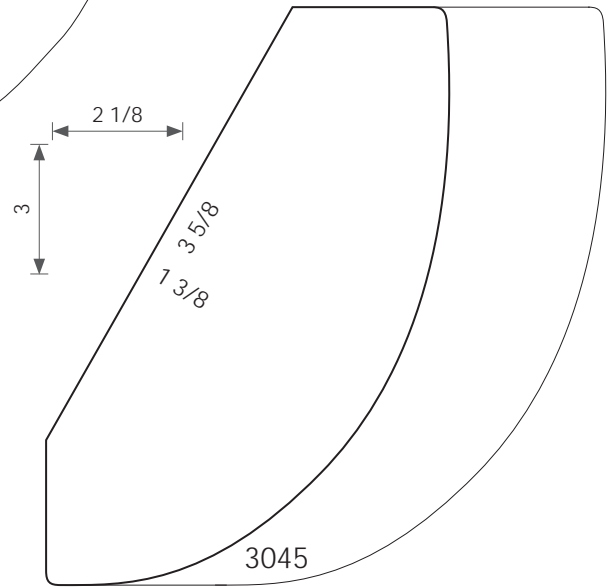
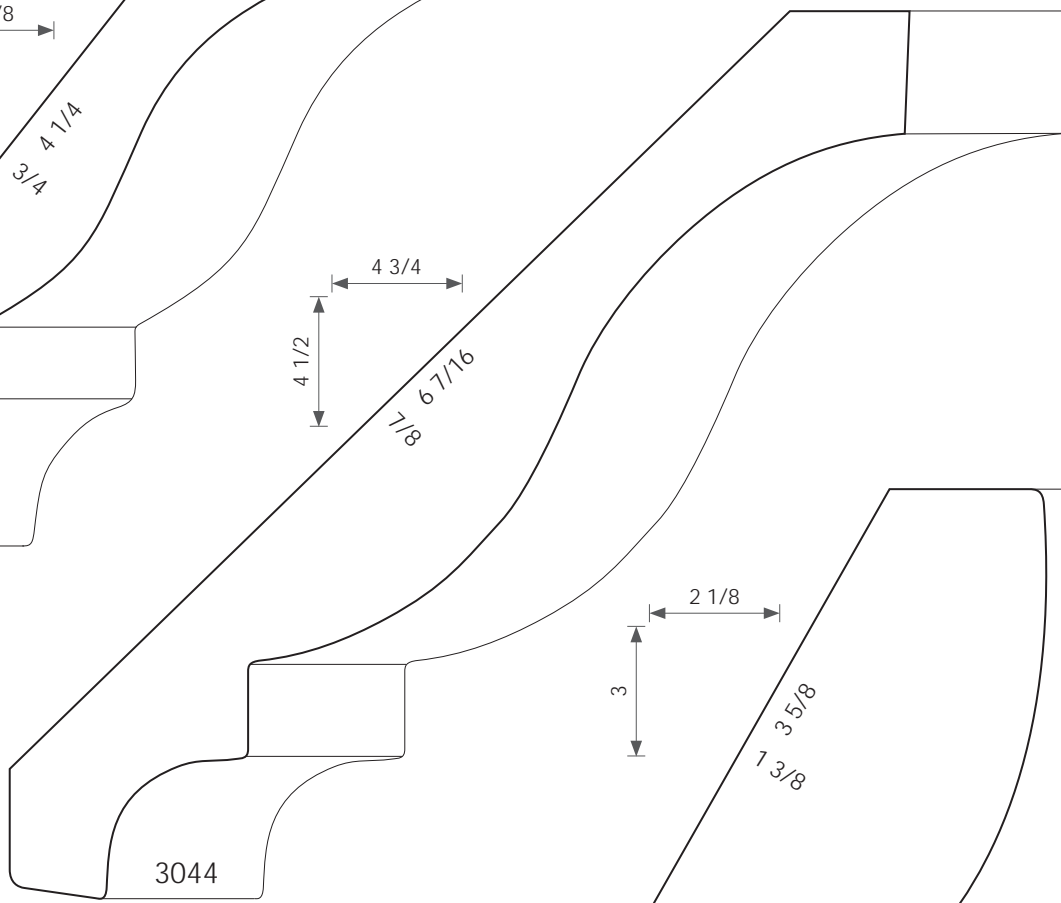
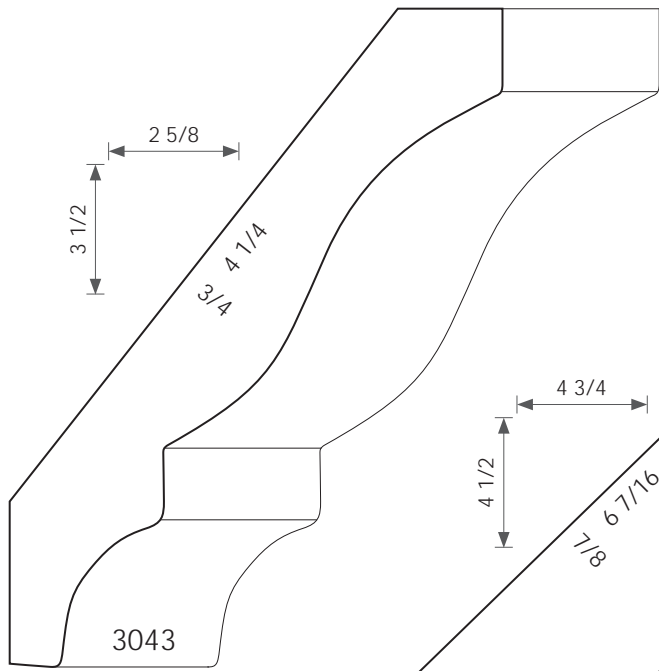

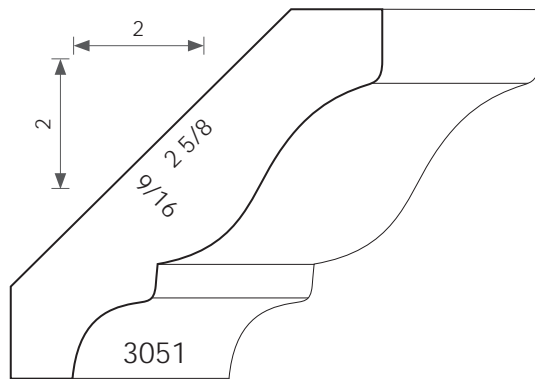
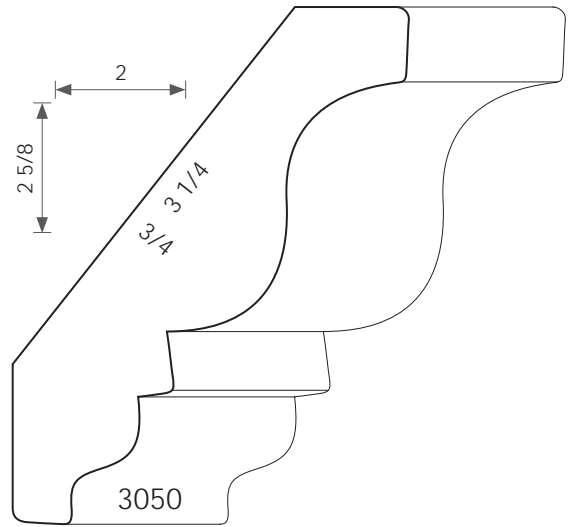
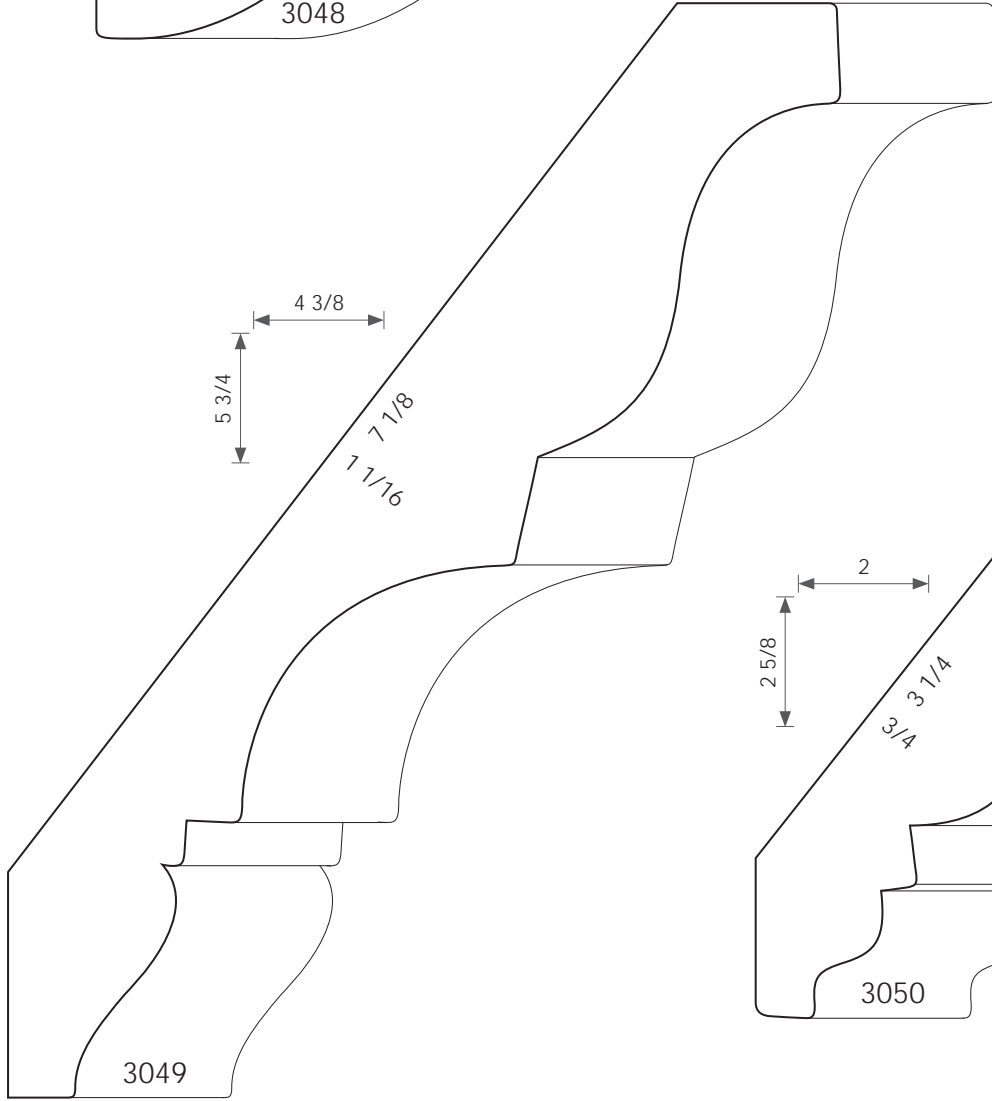
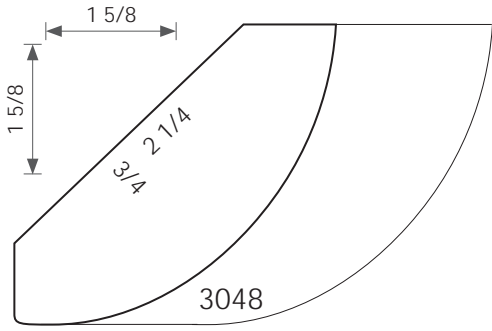

Crown

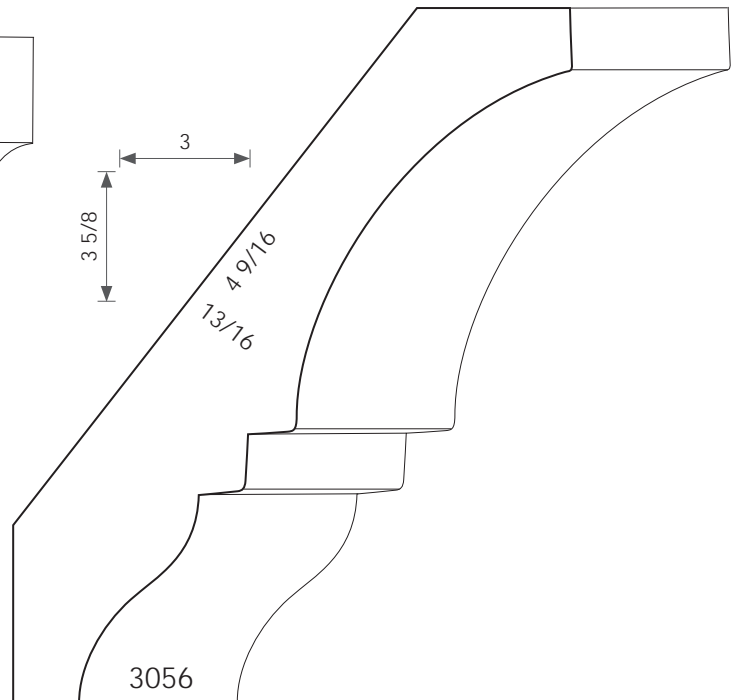
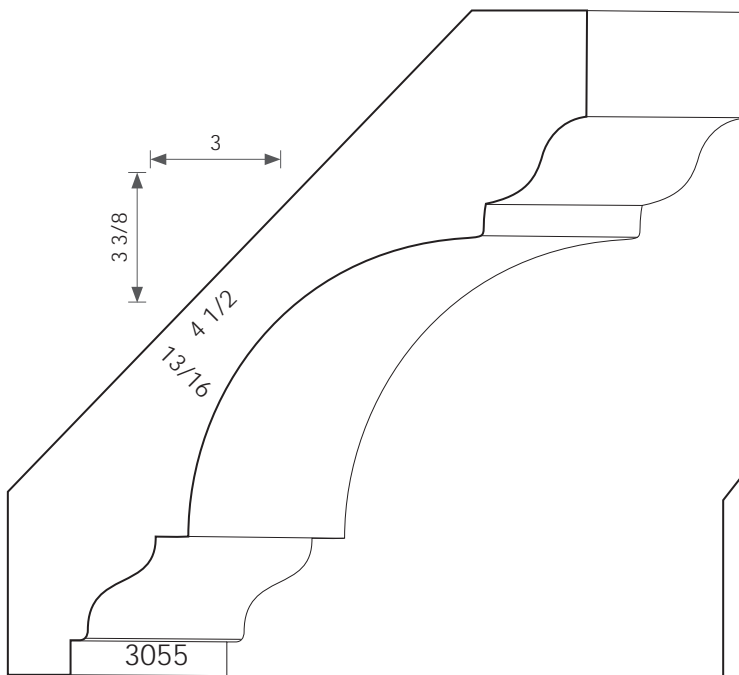
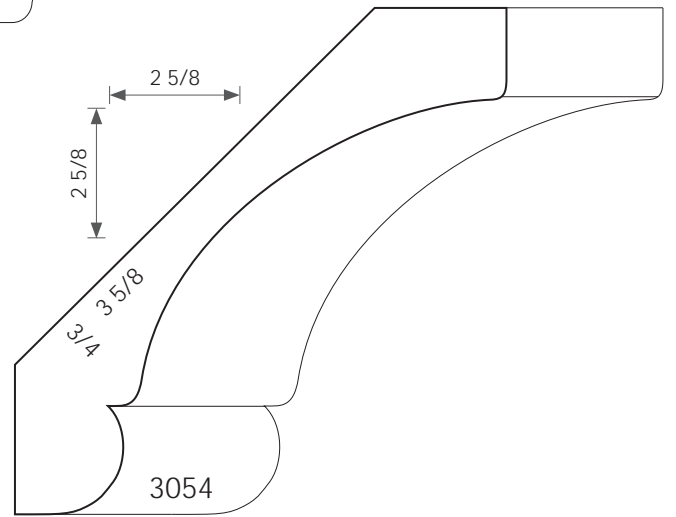
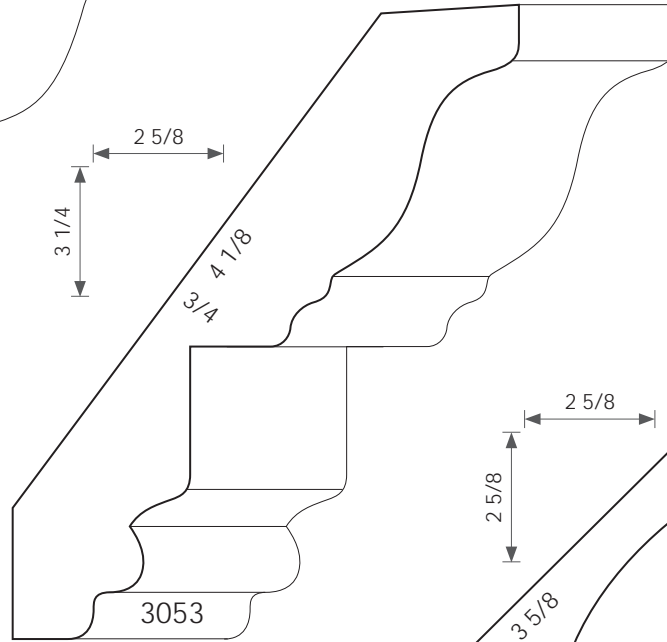
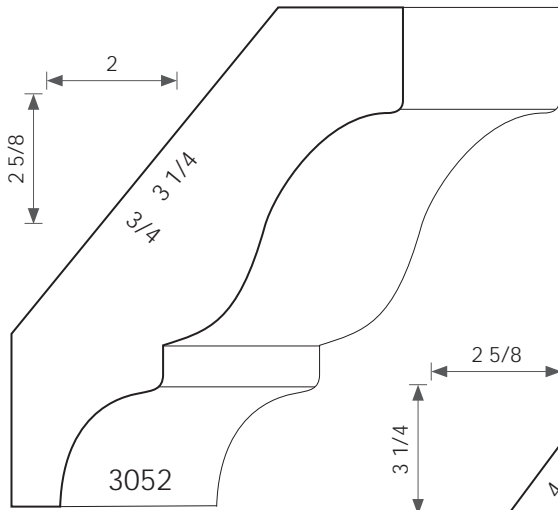

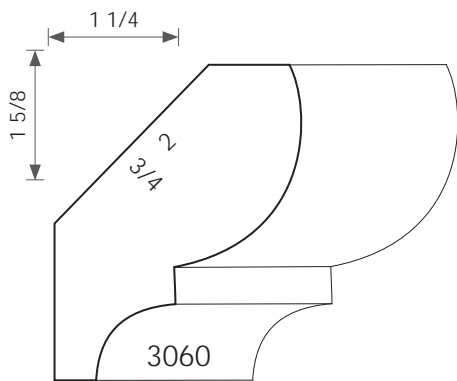
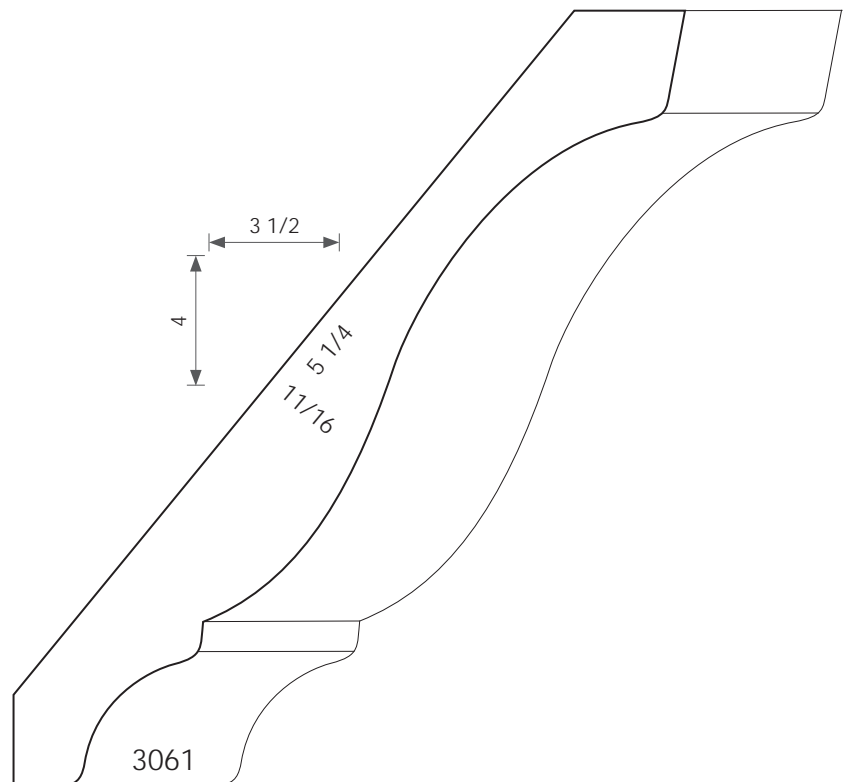
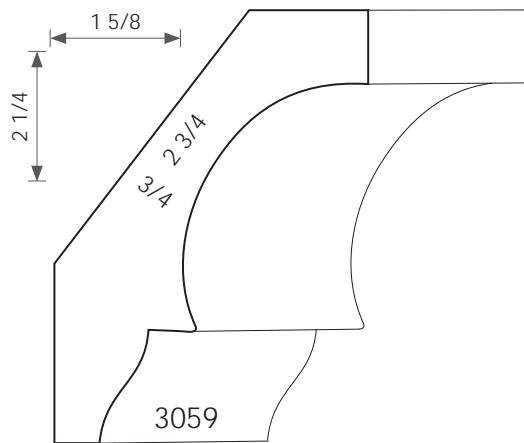
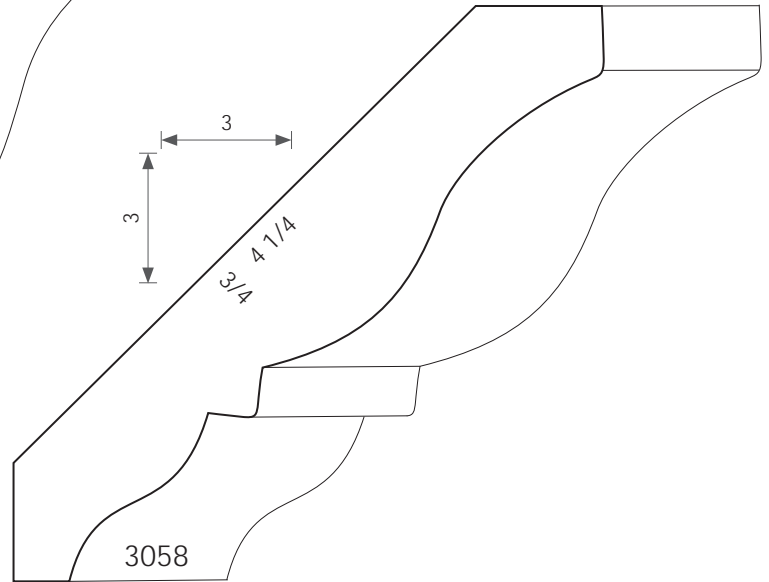
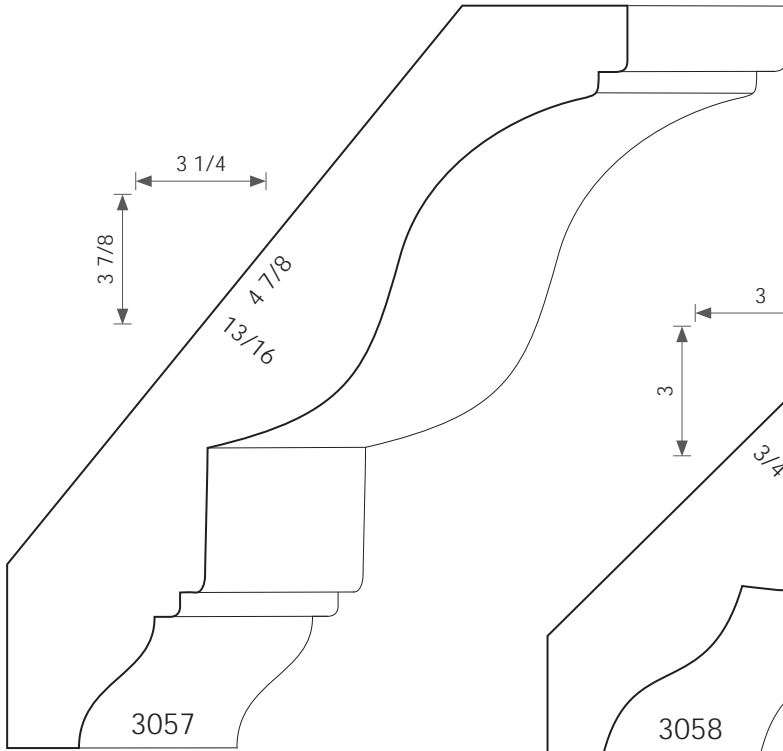

Crown

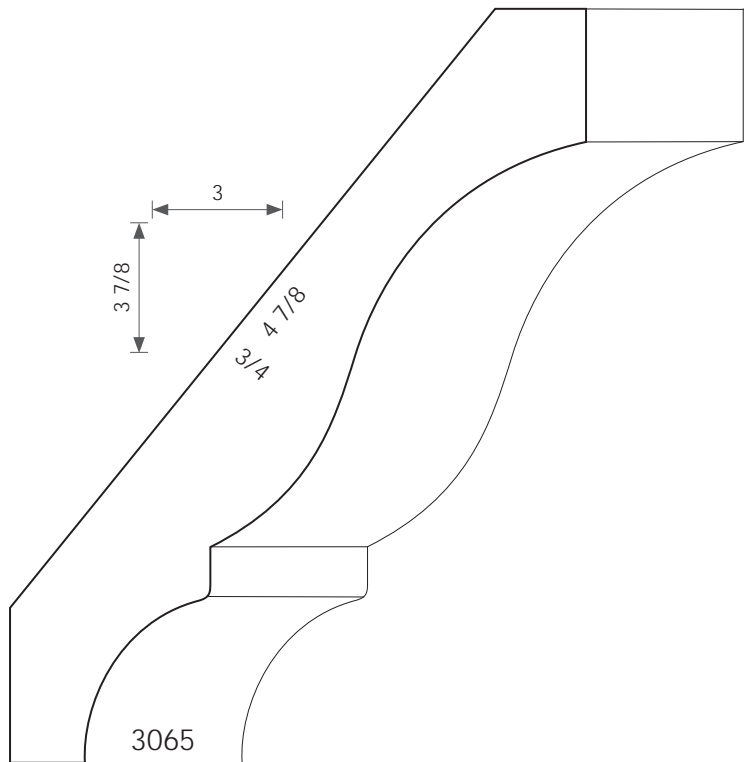
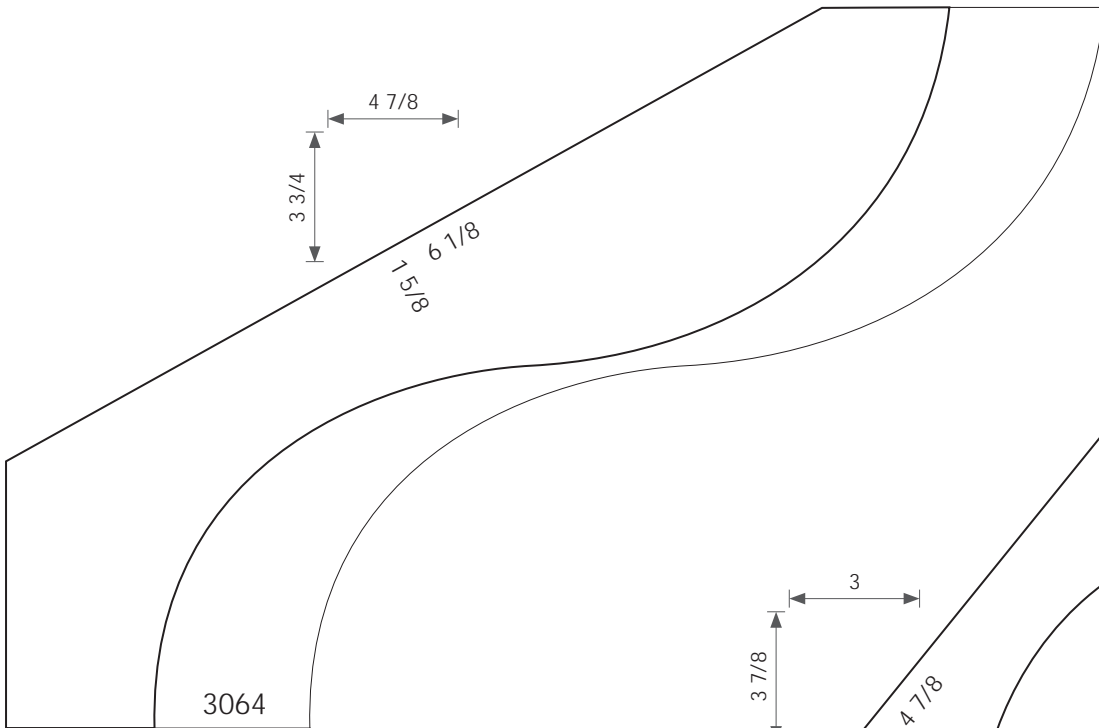
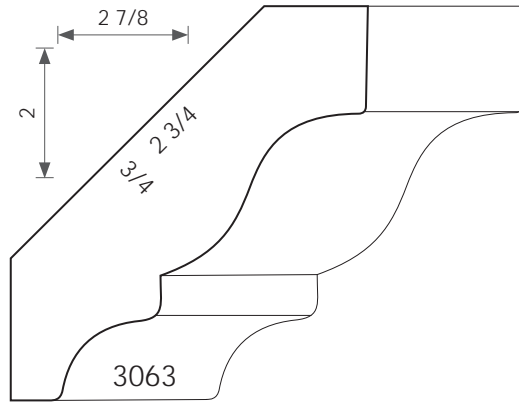
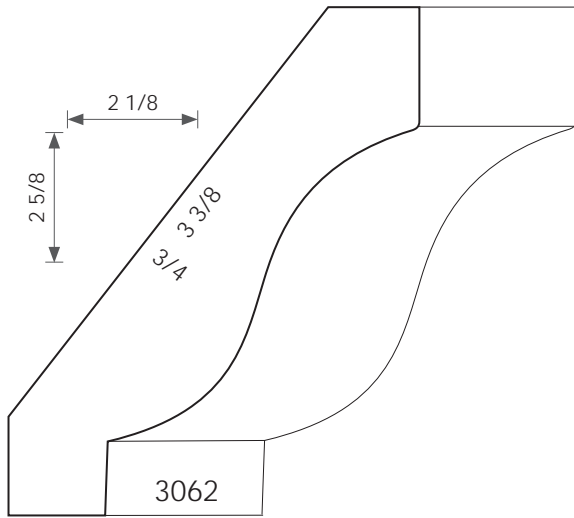

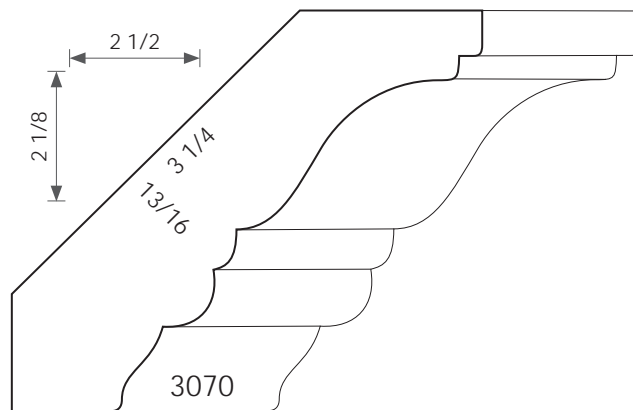
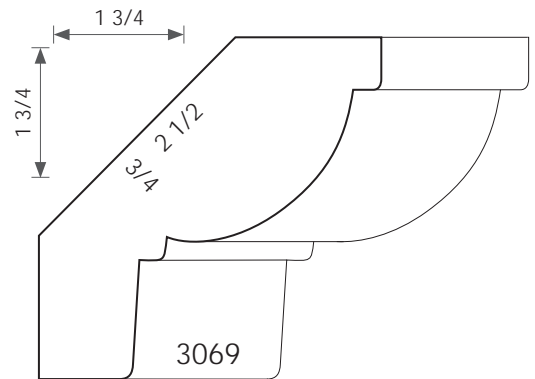
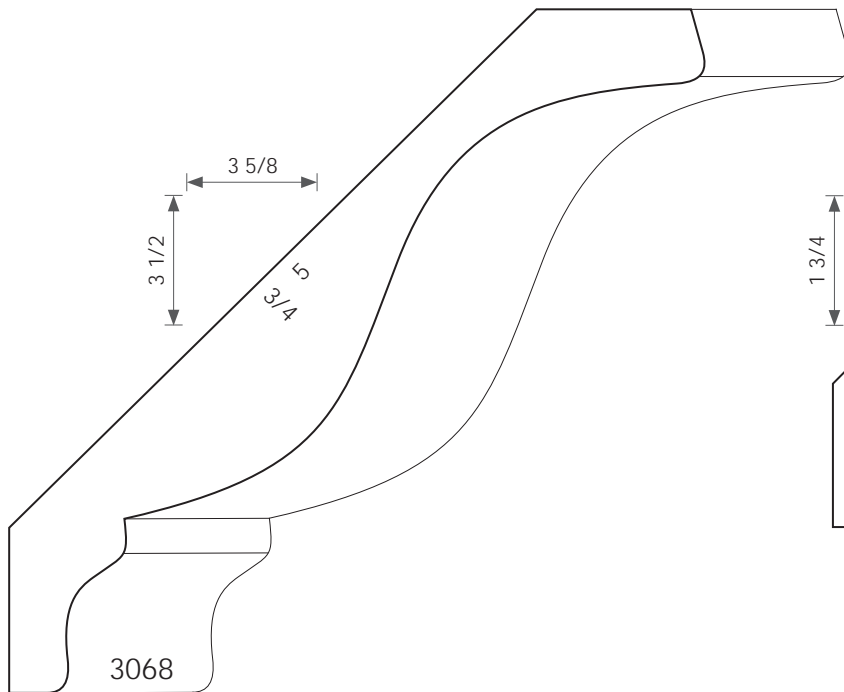
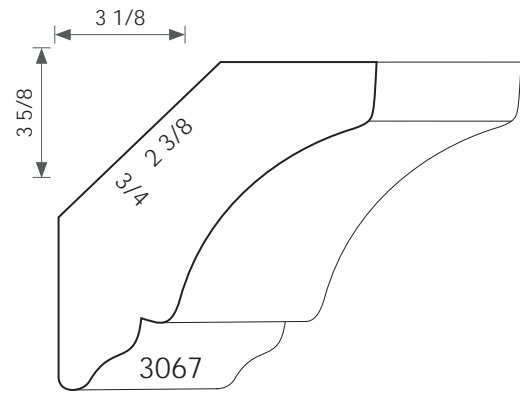
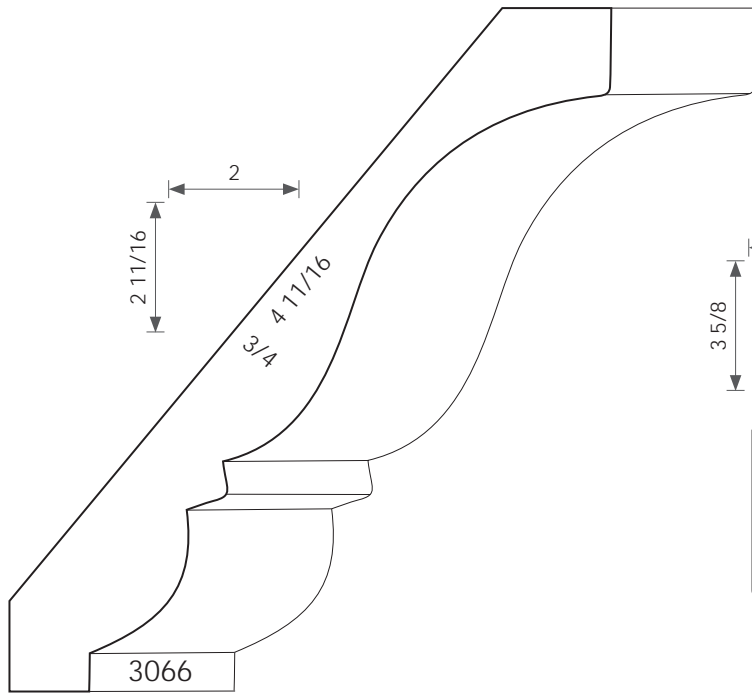

Crown

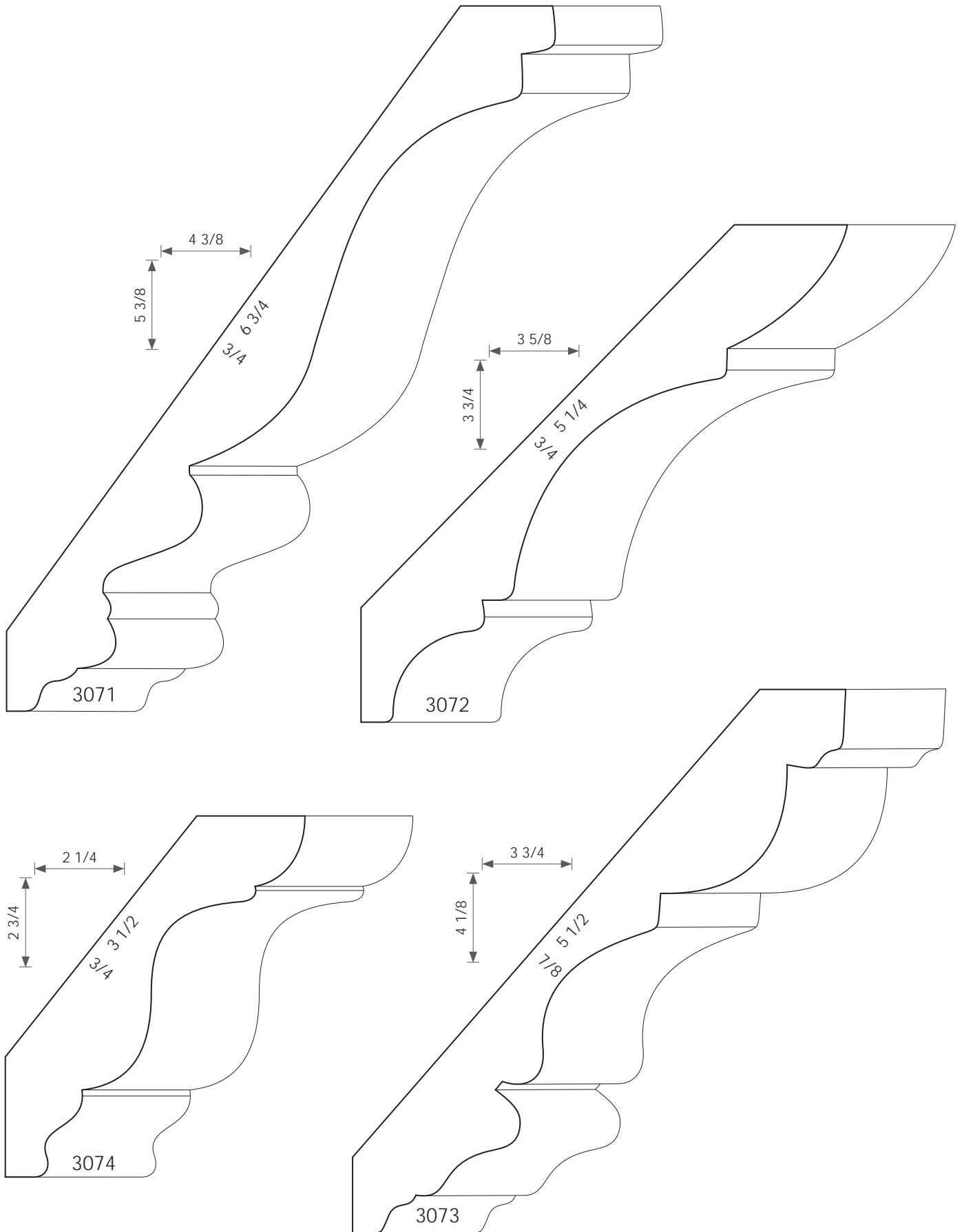

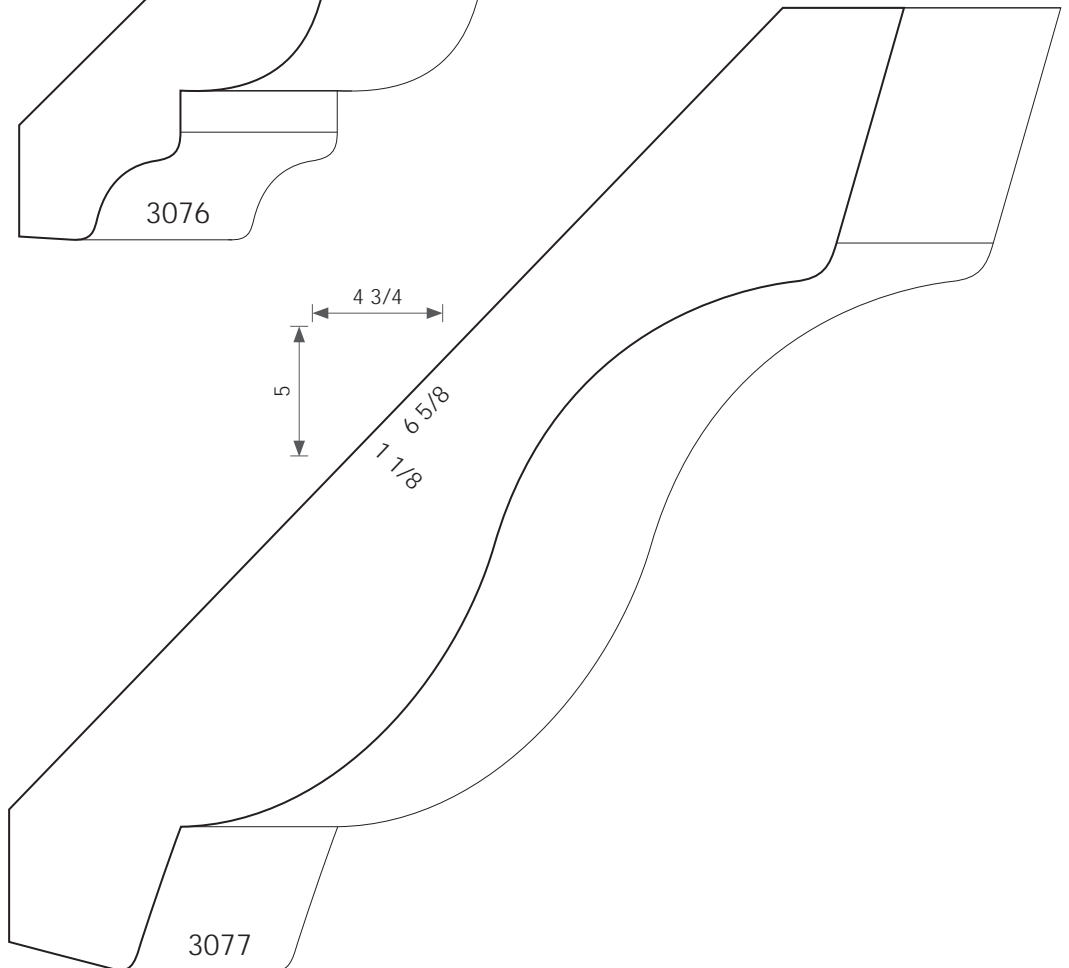
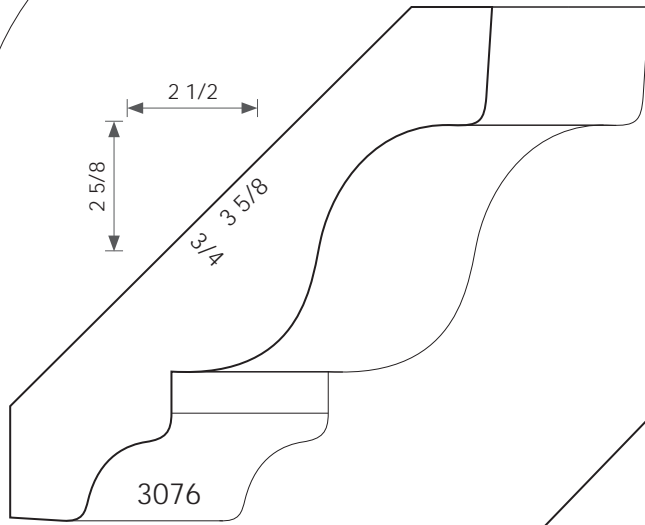
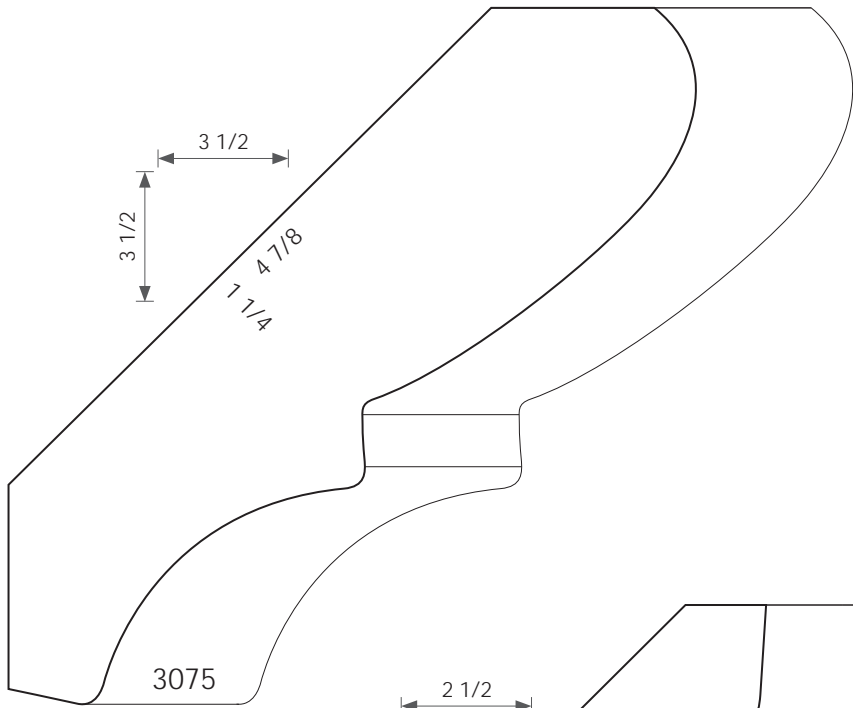

Crown

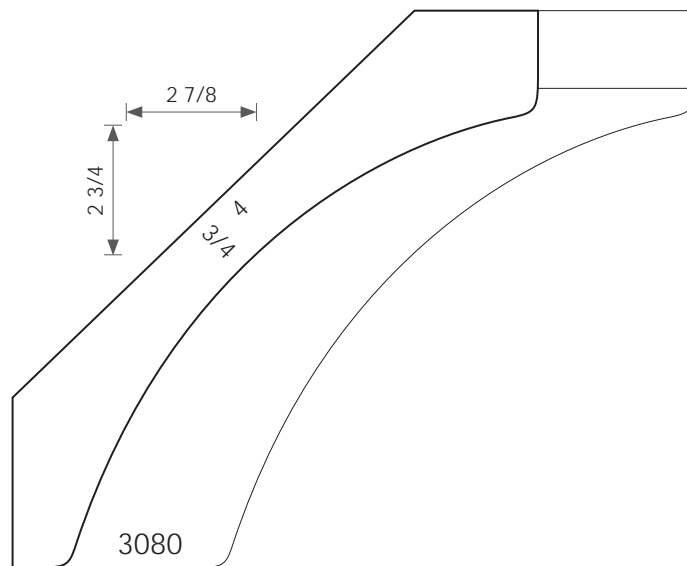
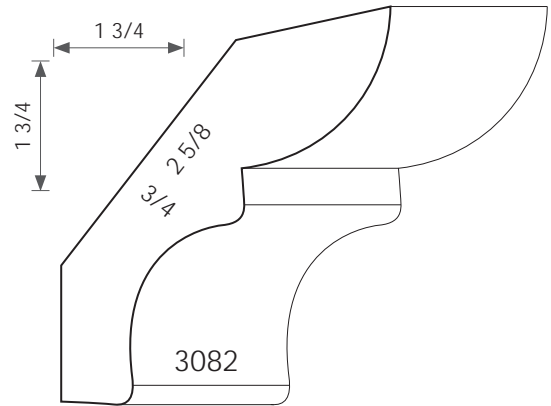
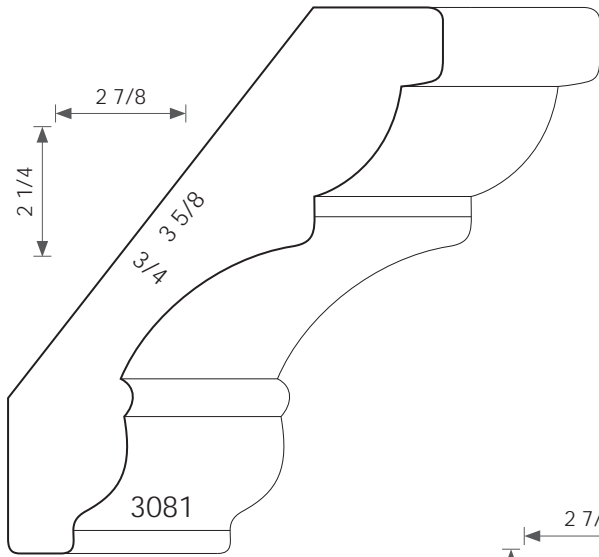
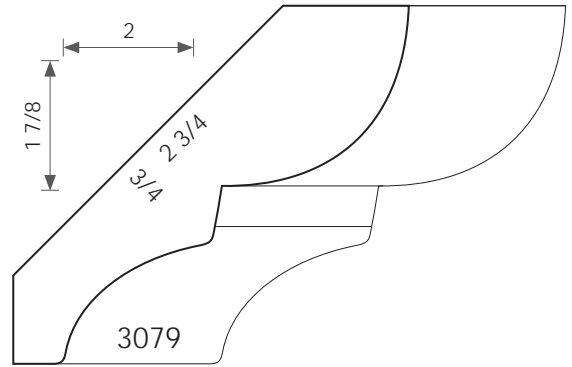
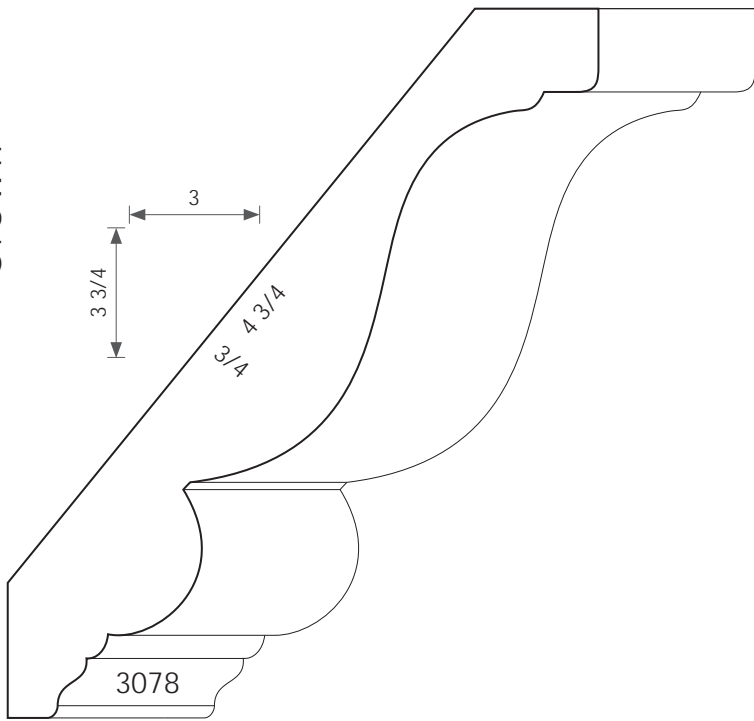

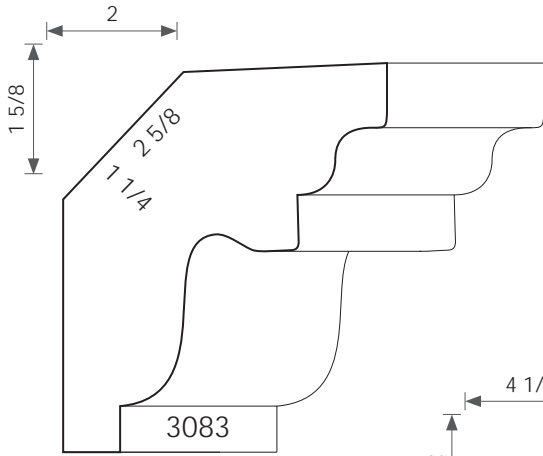
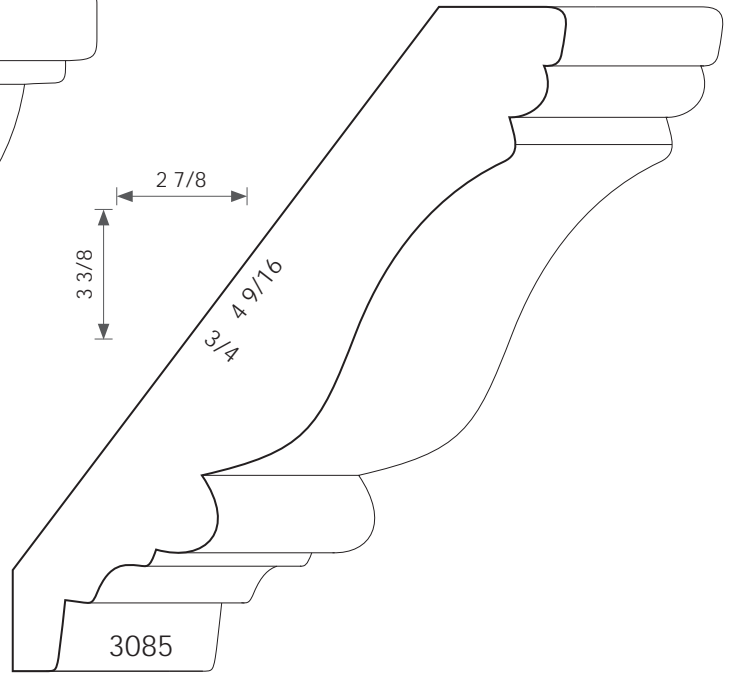
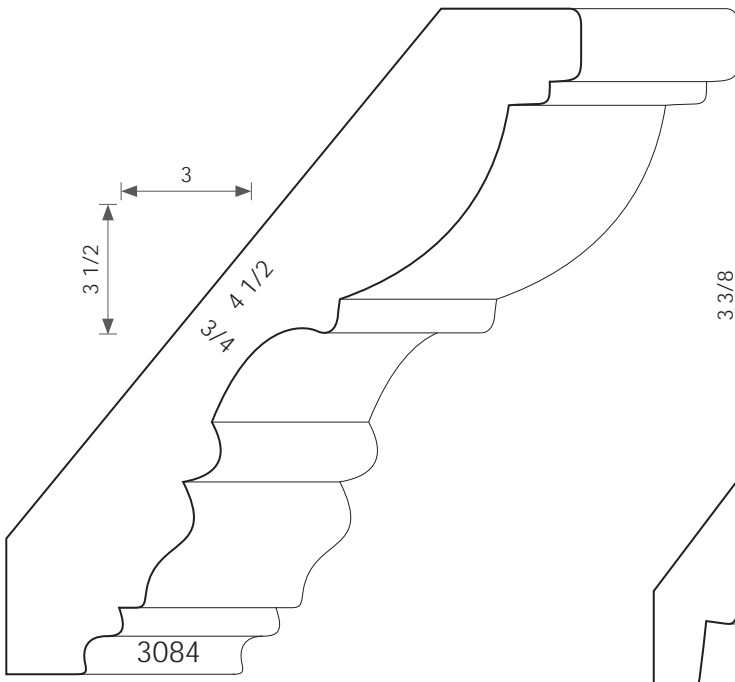

Crown

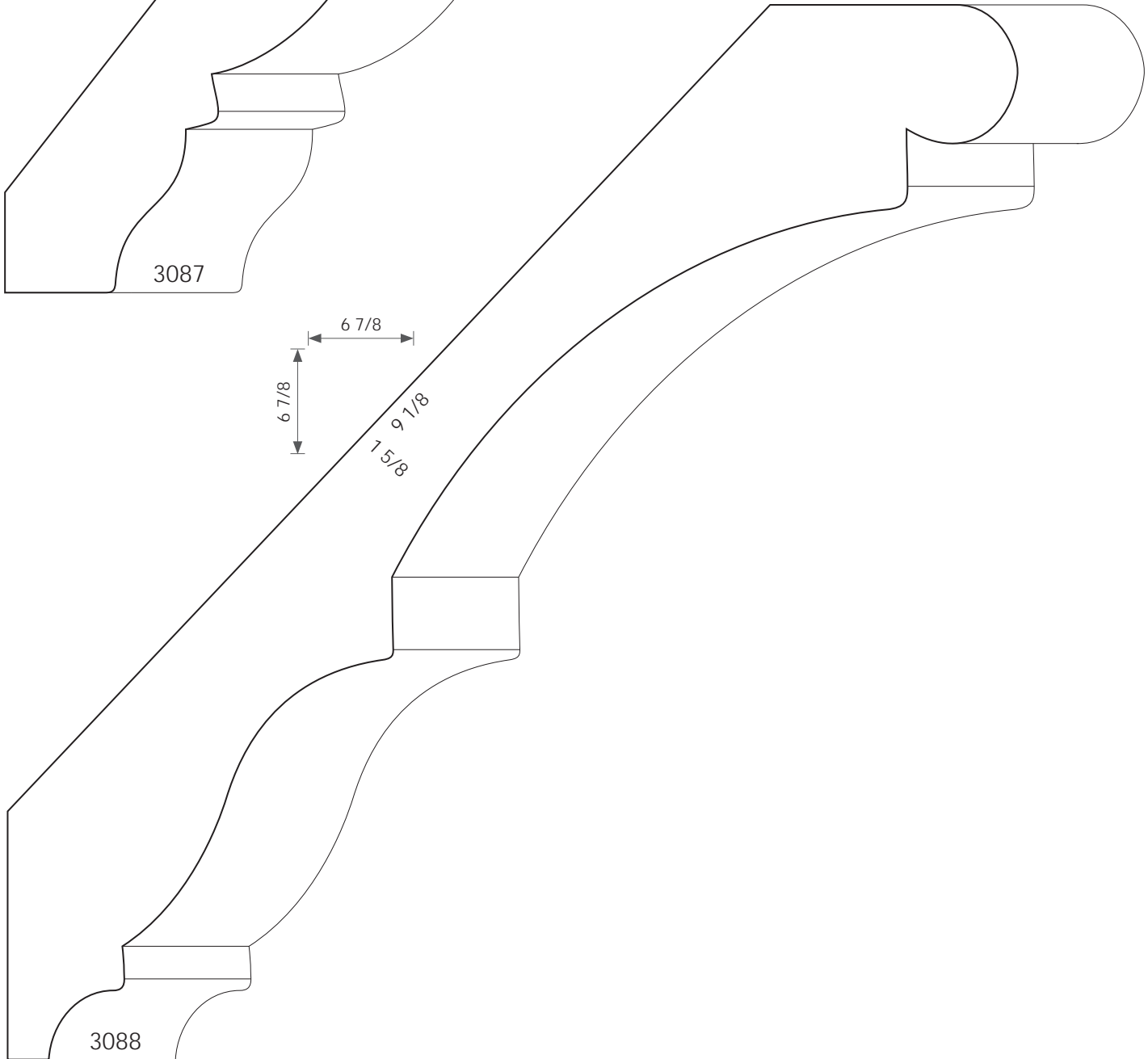
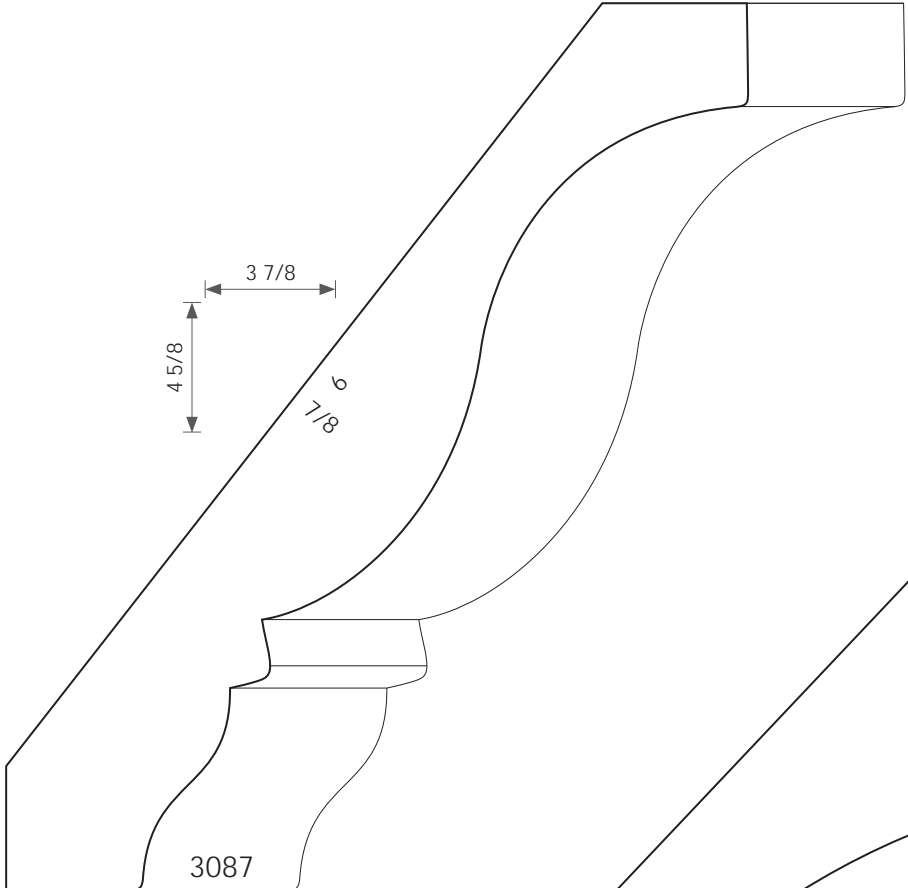

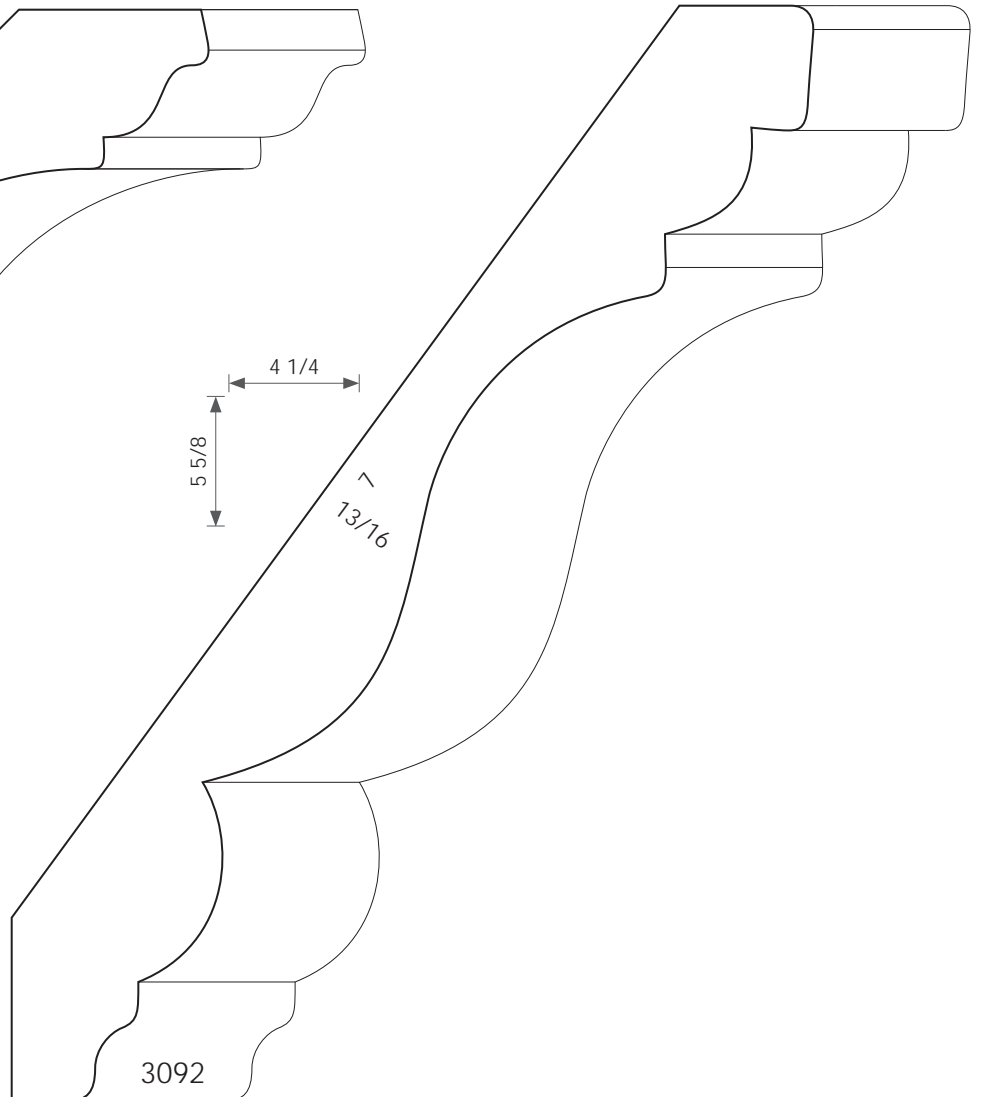
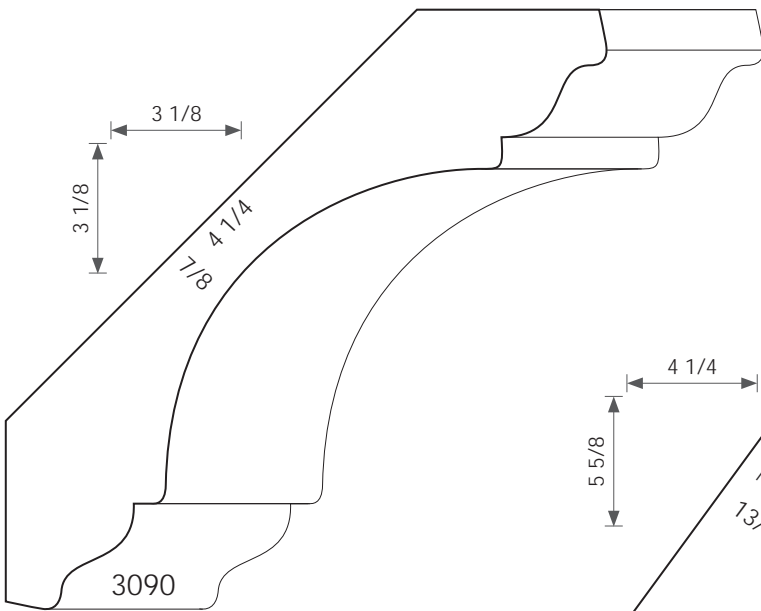
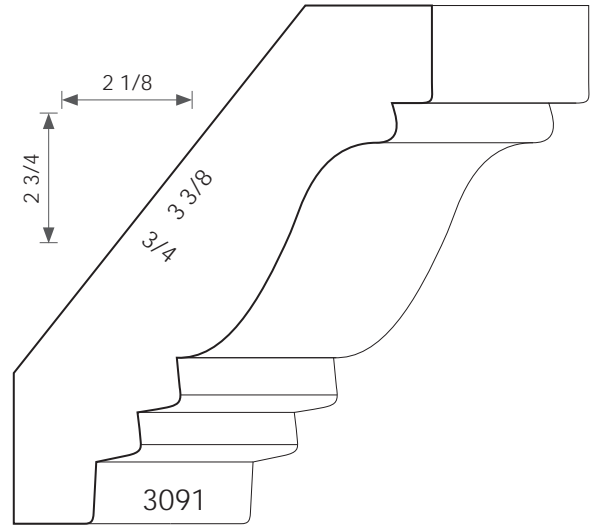
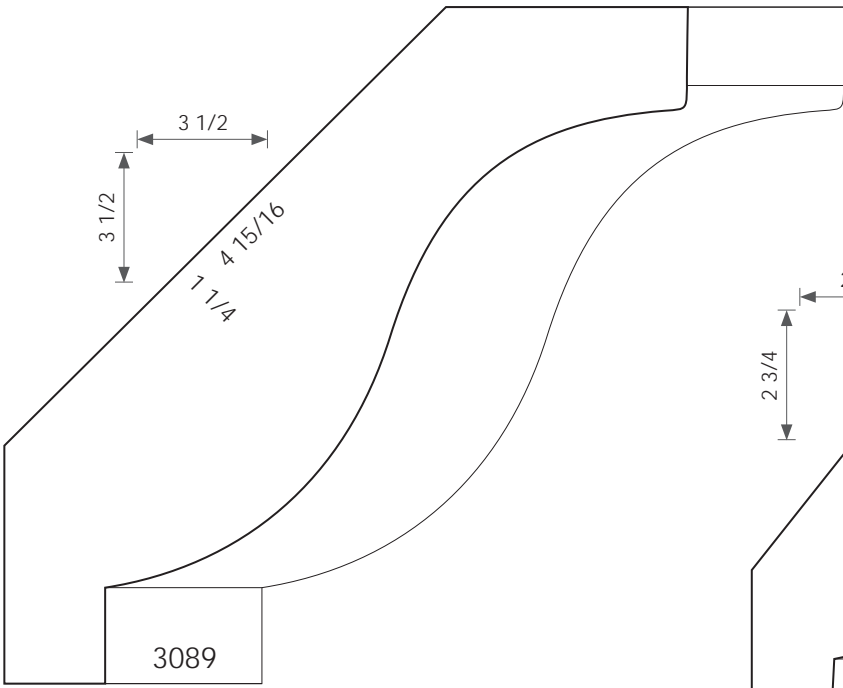

Crown

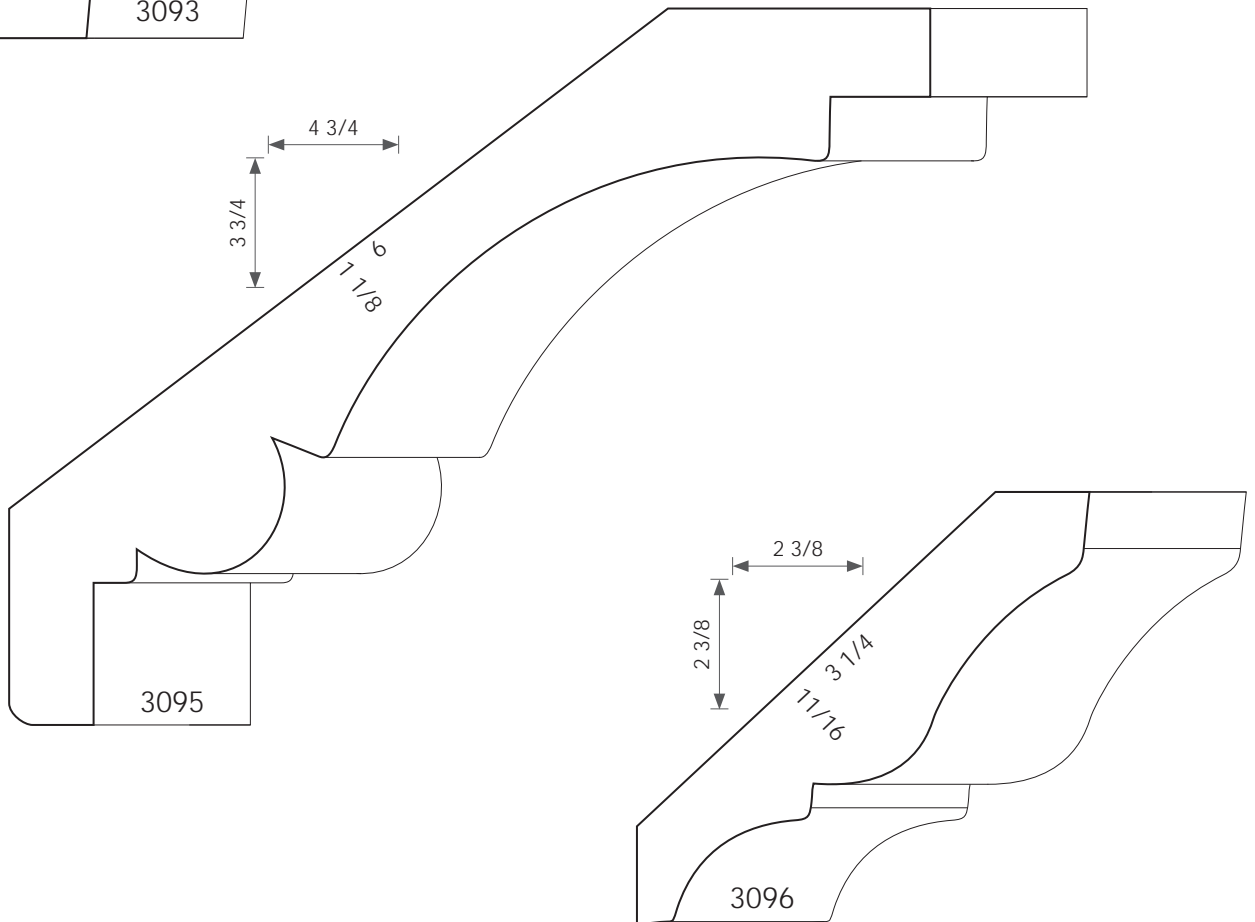
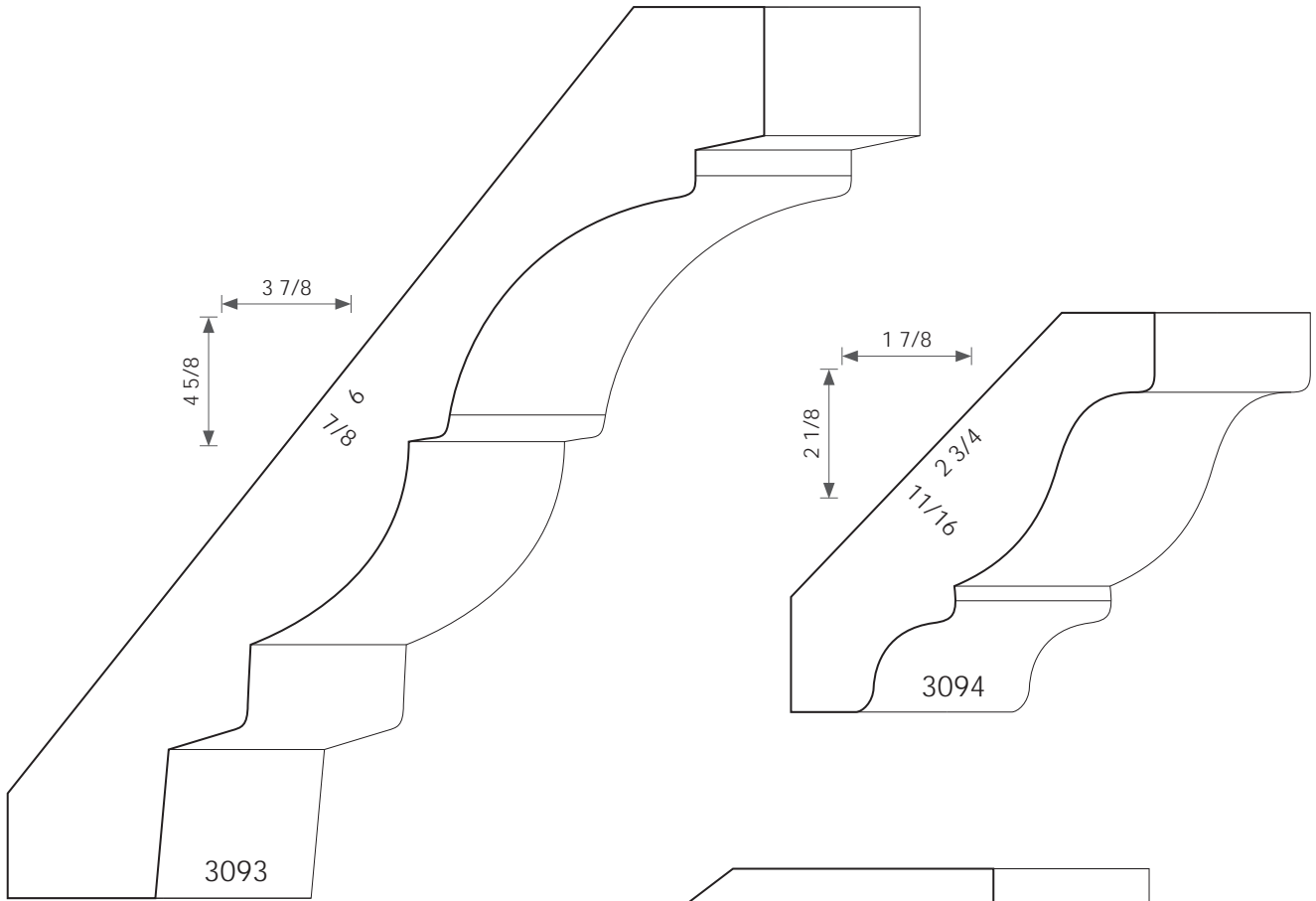

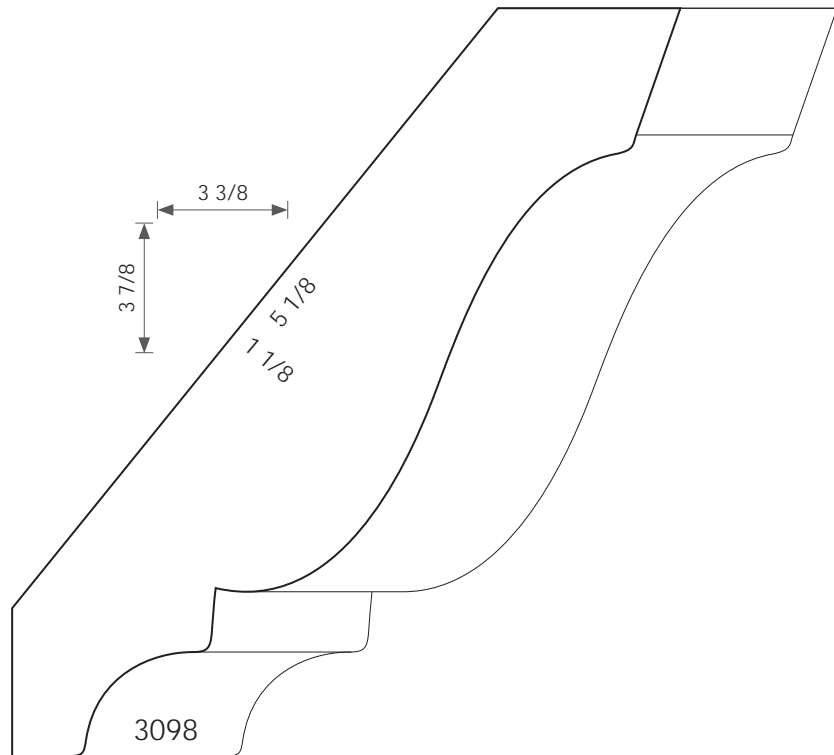
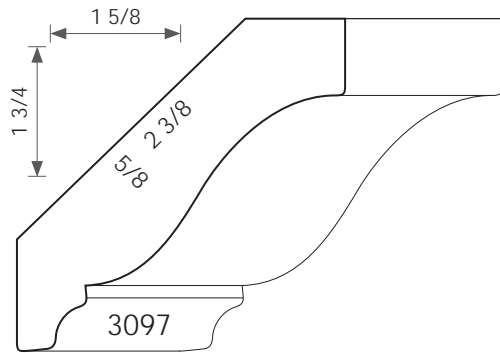

Cove

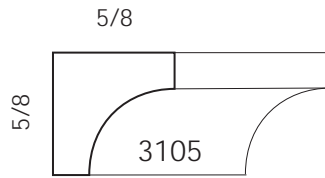
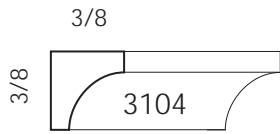
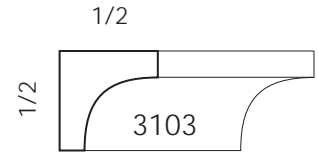
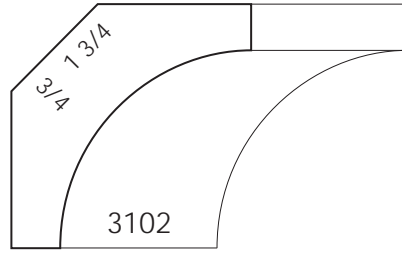
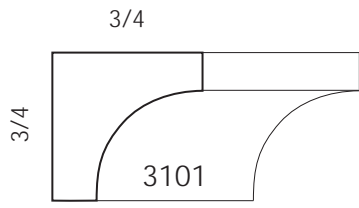

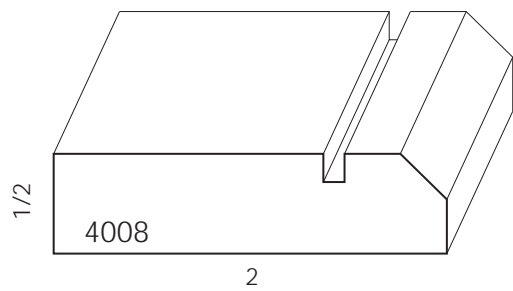
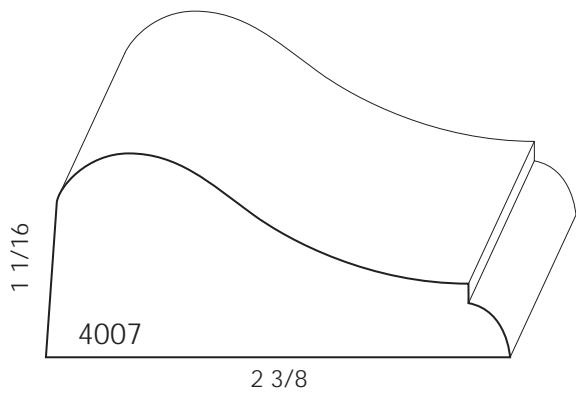
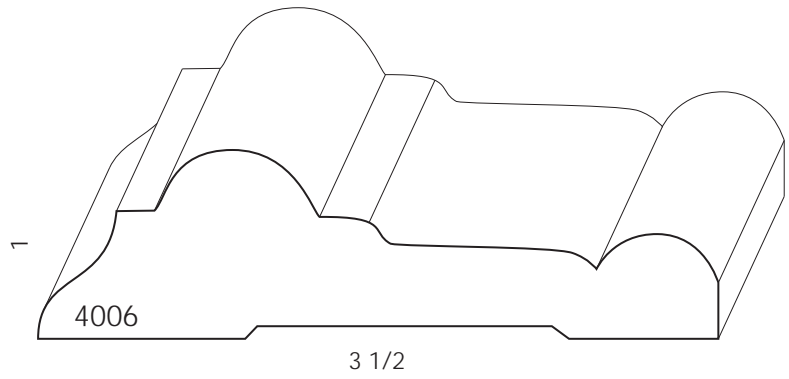
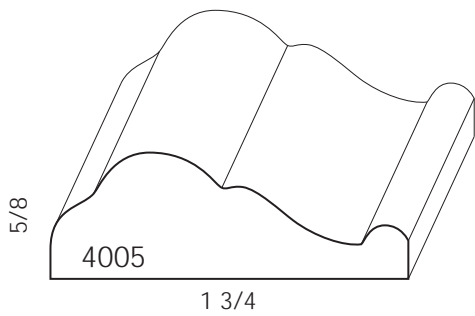
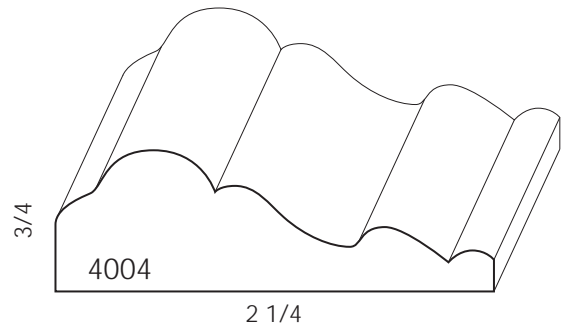
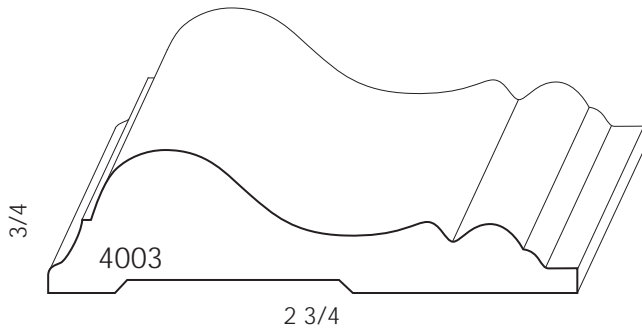
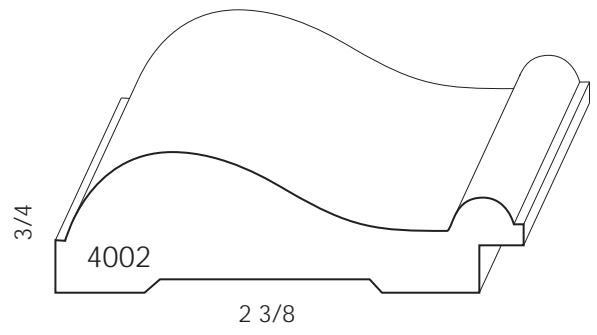
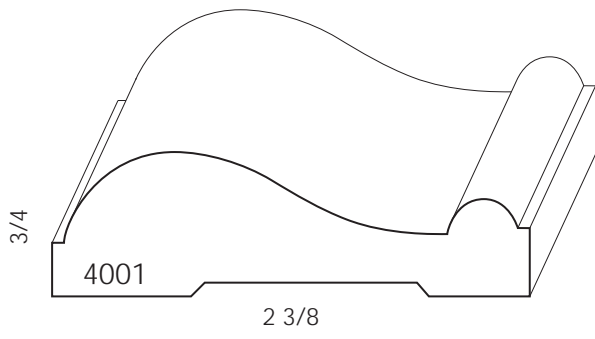

Chair Rail

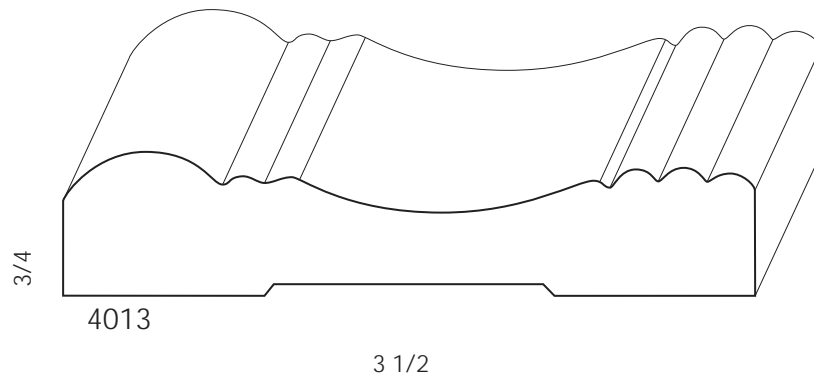
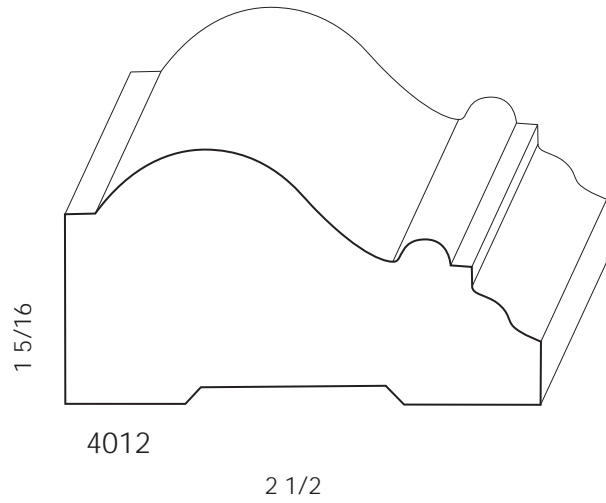
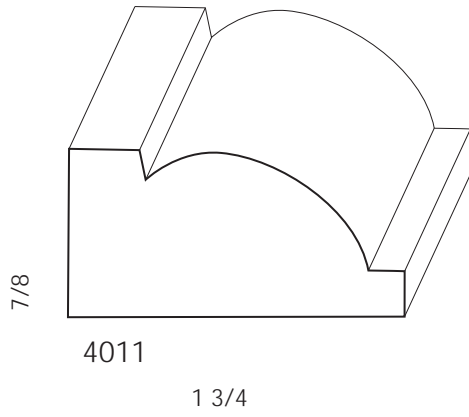
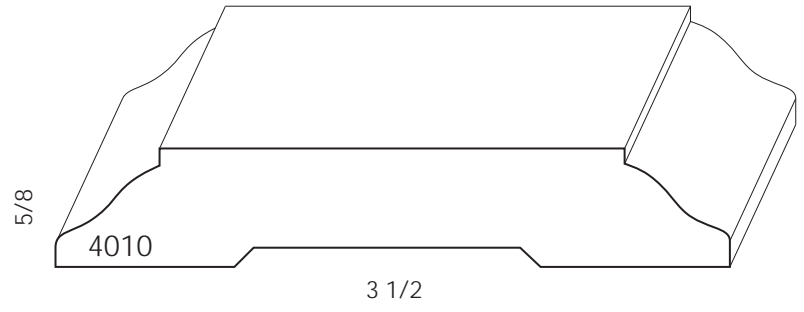
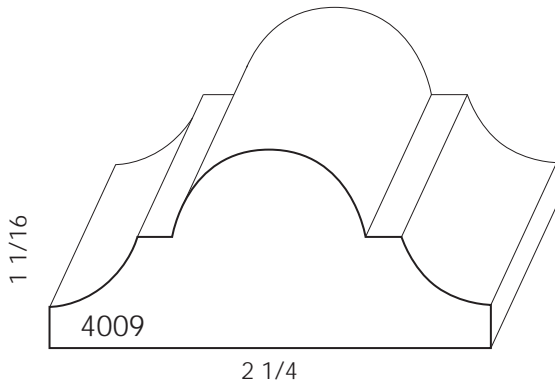

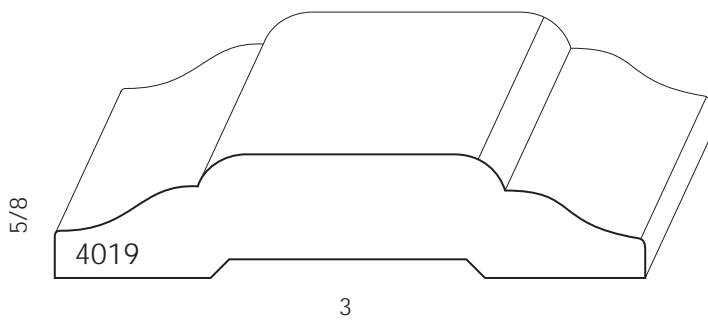
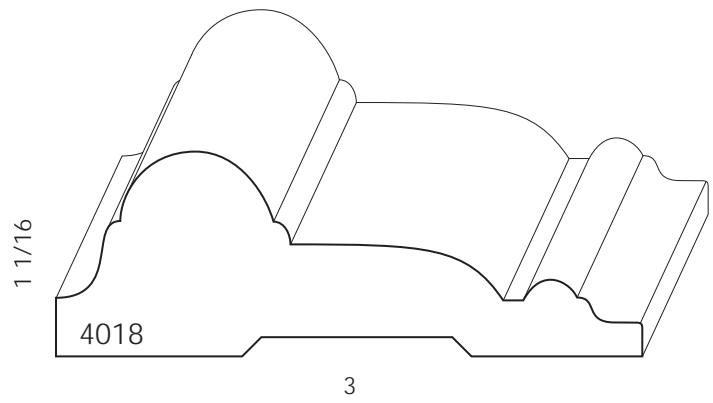
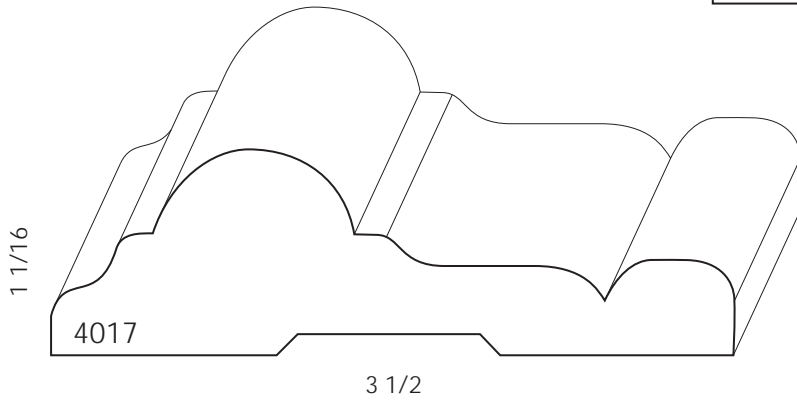
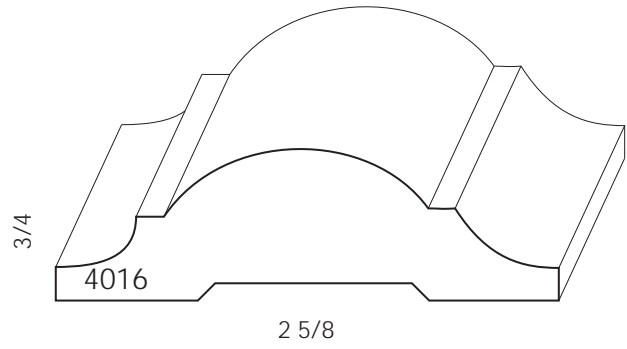
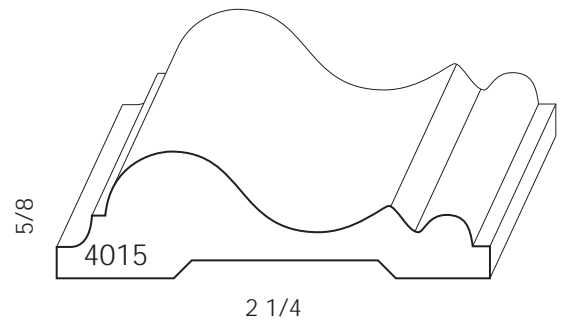
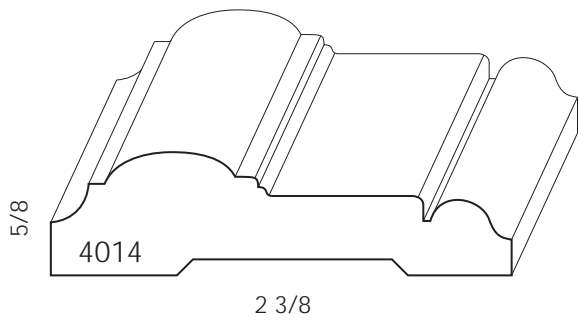

Chair Rail

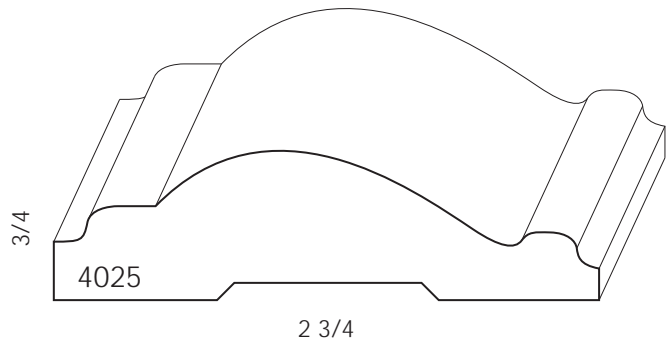
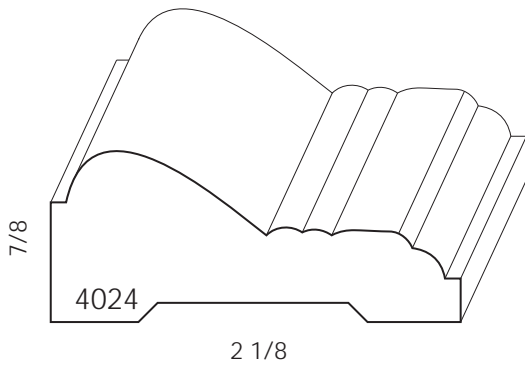
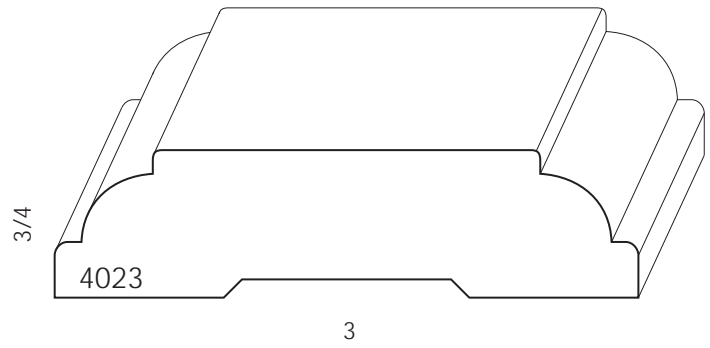
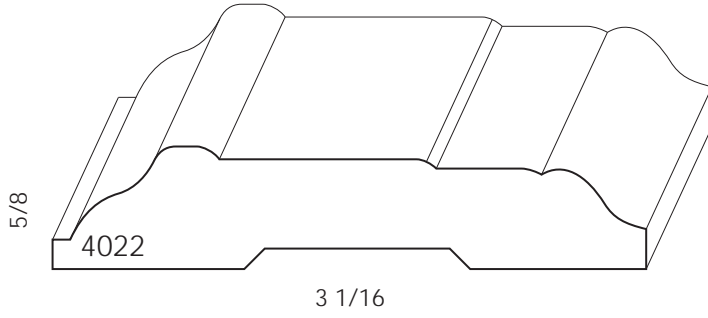
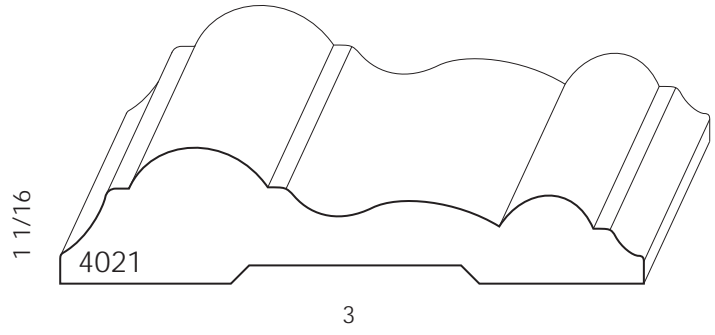
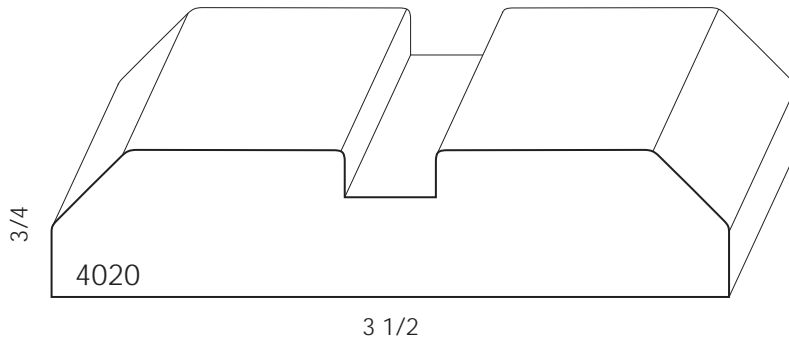

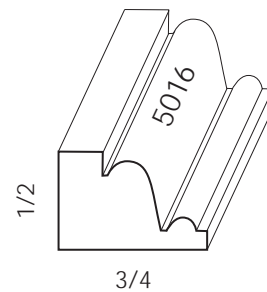
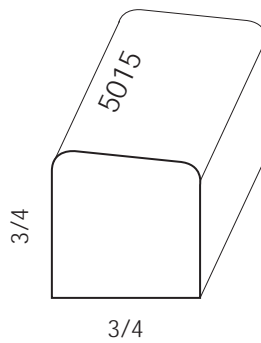
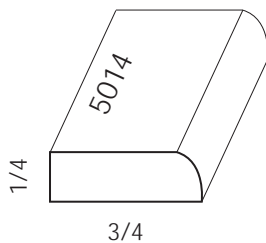
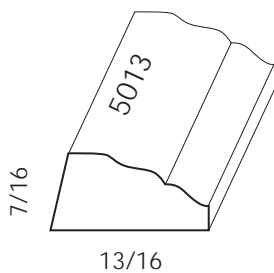
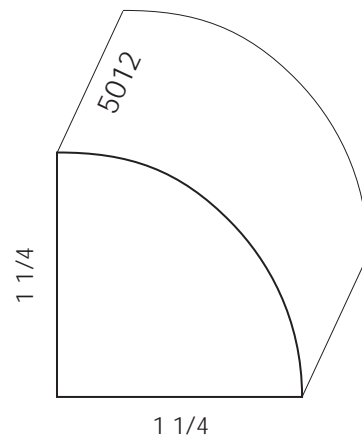
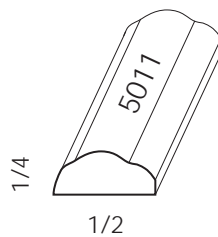
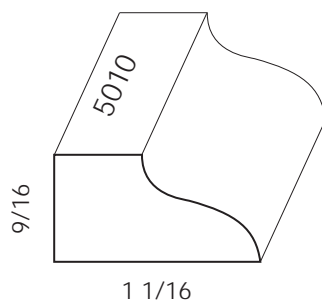
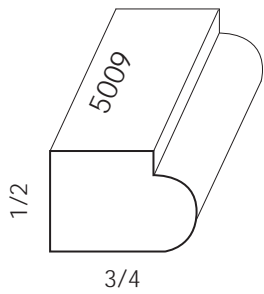
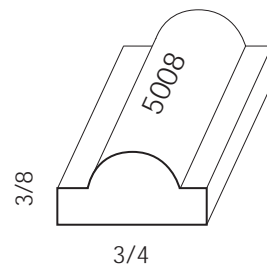
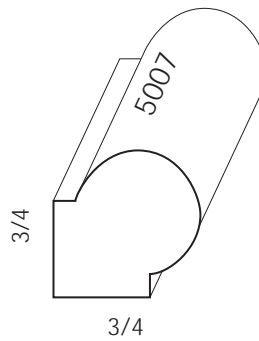
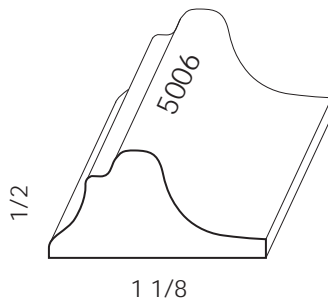
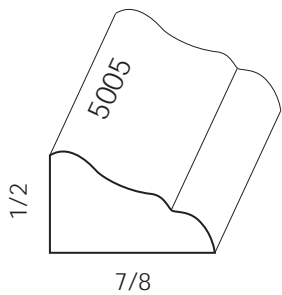
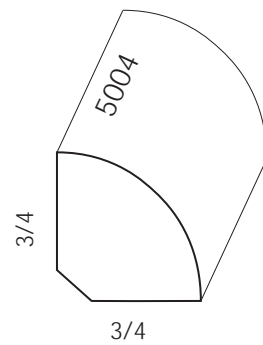
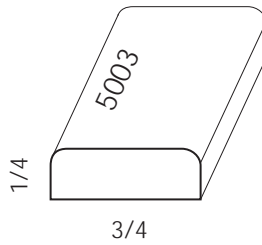
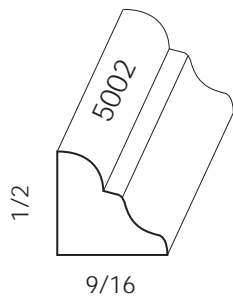
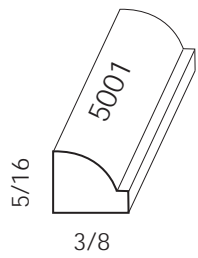

Small Mold

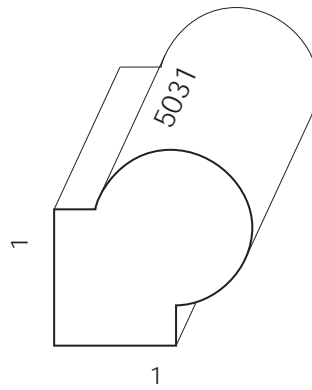
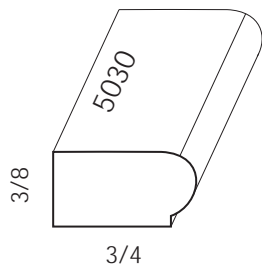
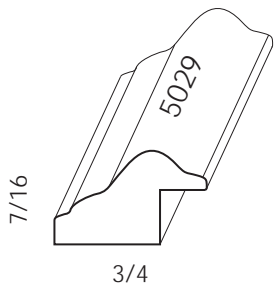
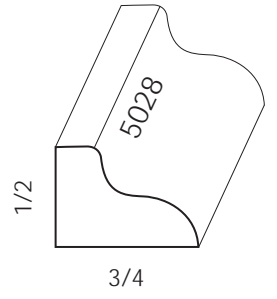
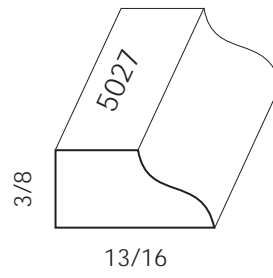
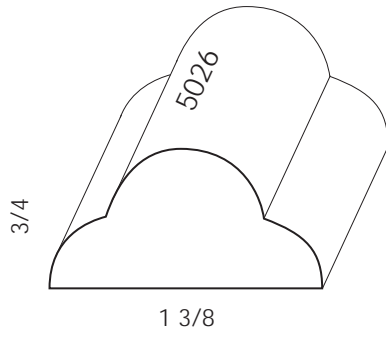
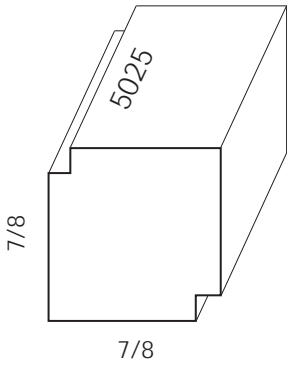
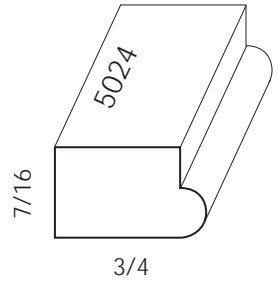
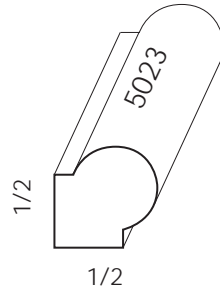
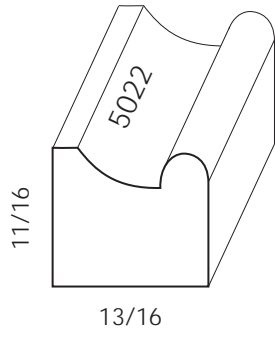
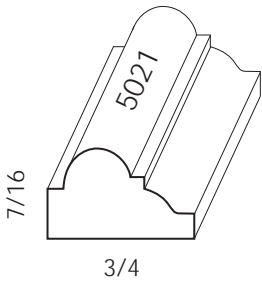
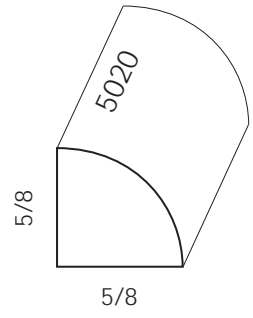
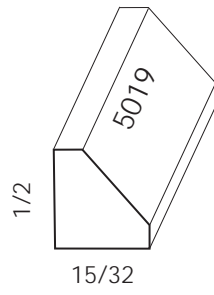
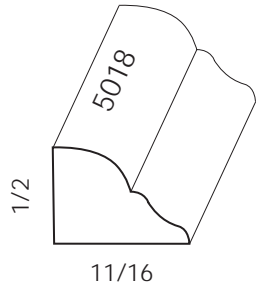
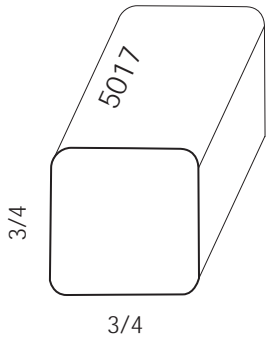

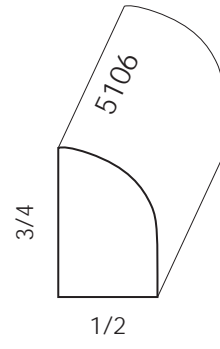
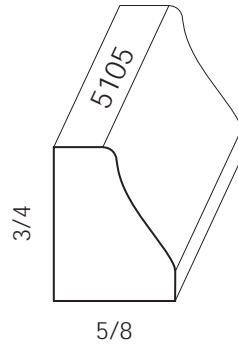
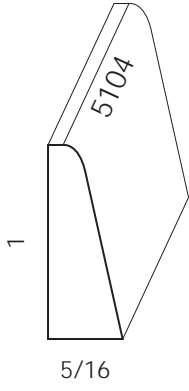
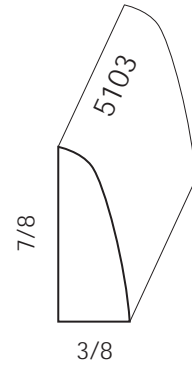
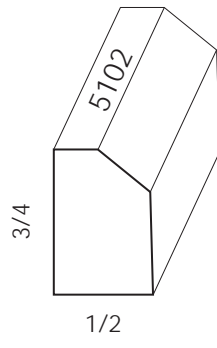
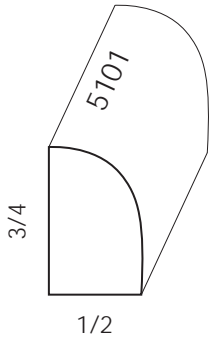

shoes

Panel Mold

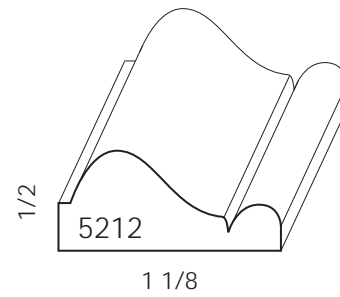
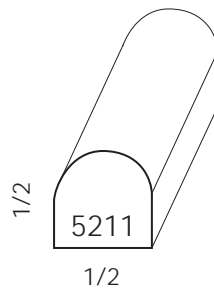
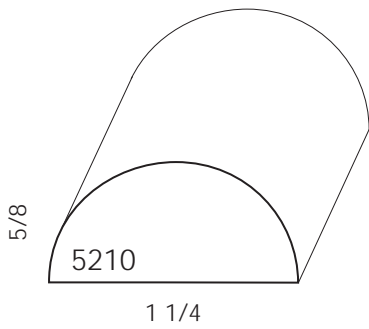
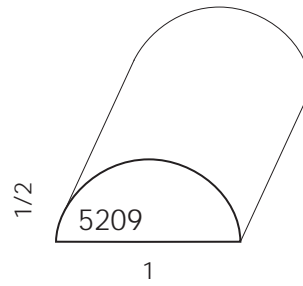
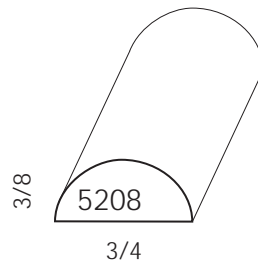
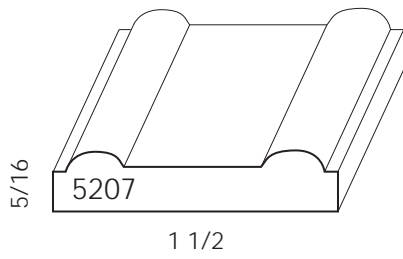
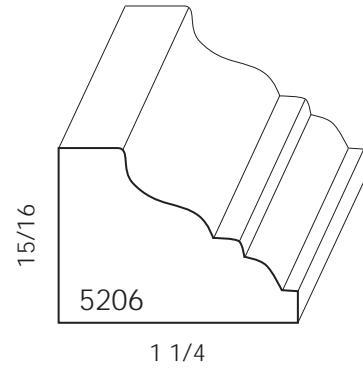
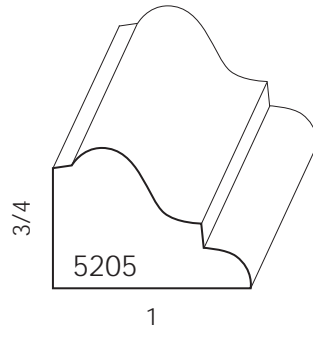
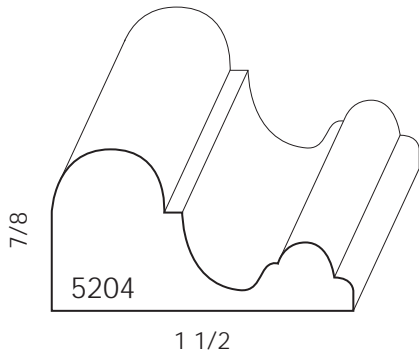
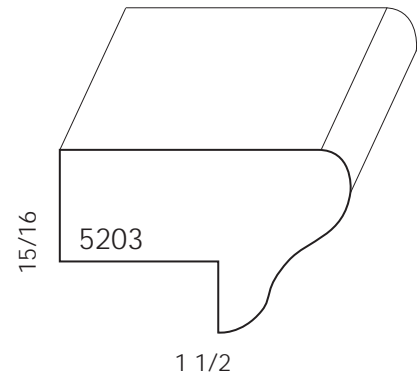
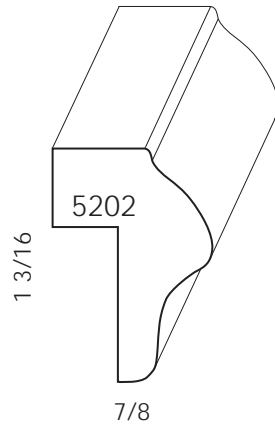
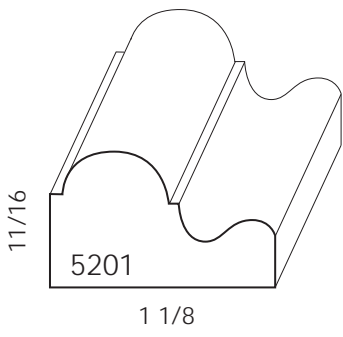

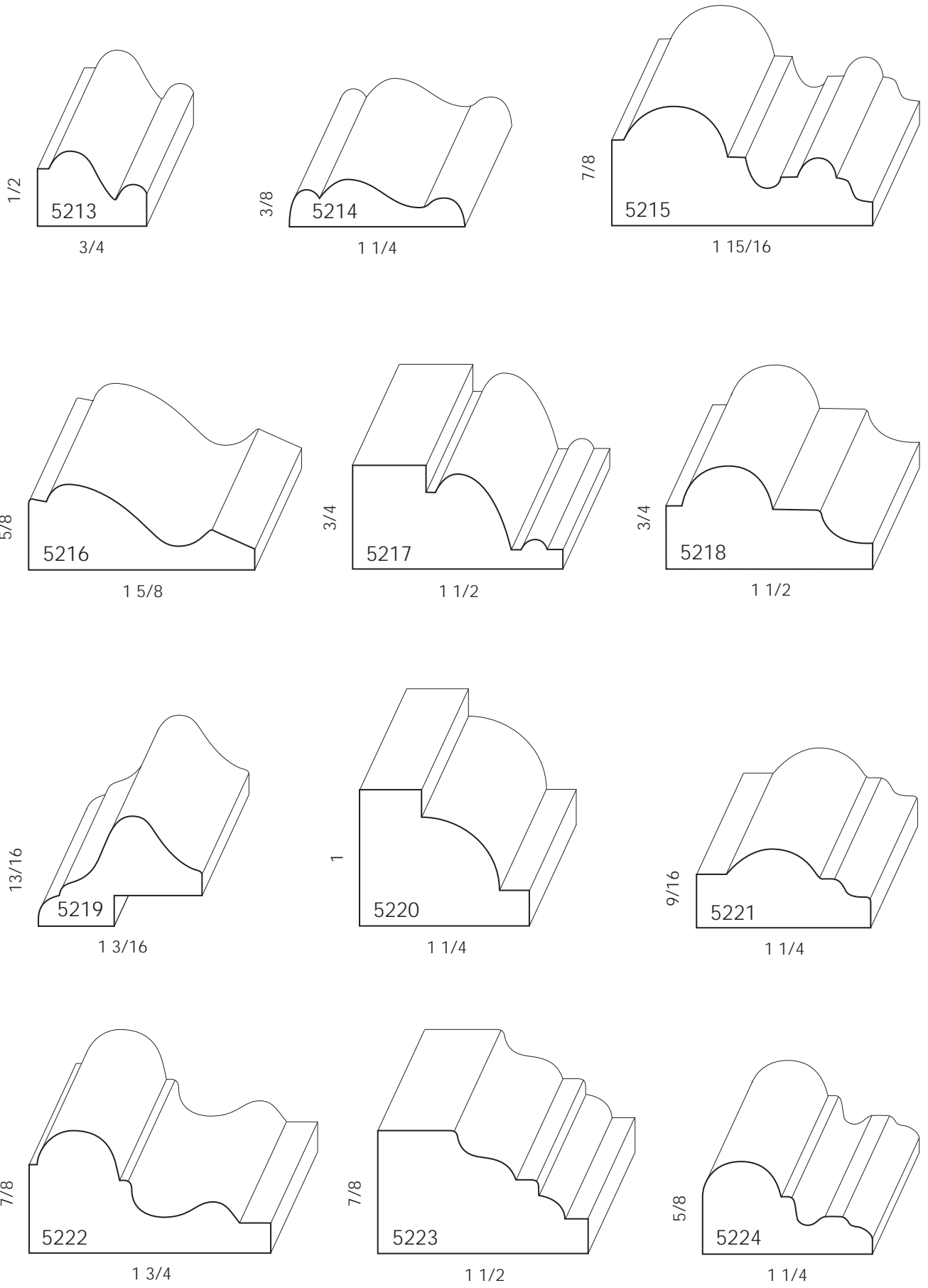

Panel Mold

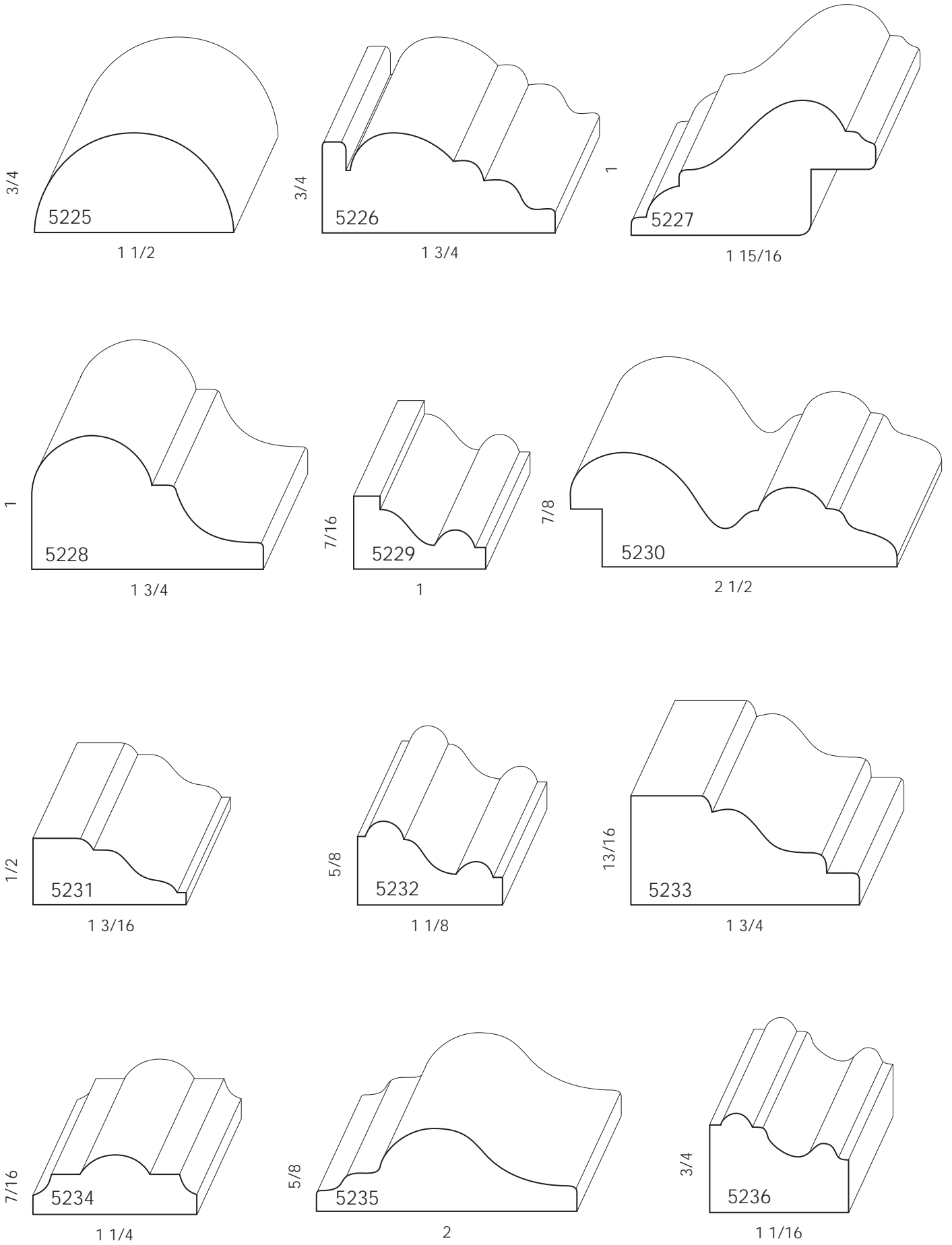

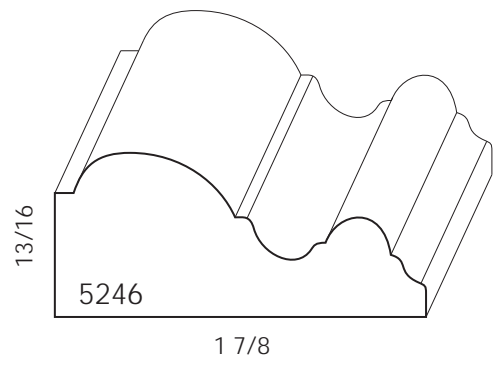
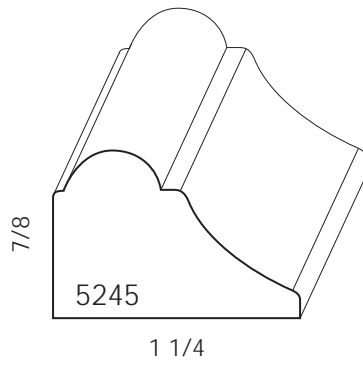
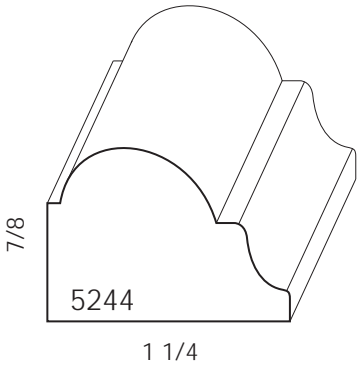
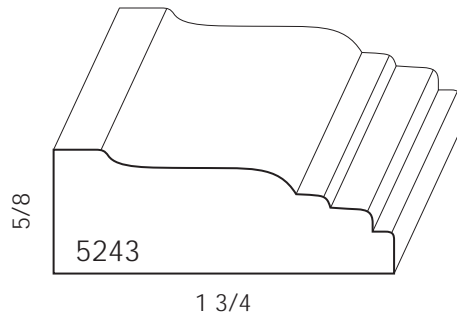
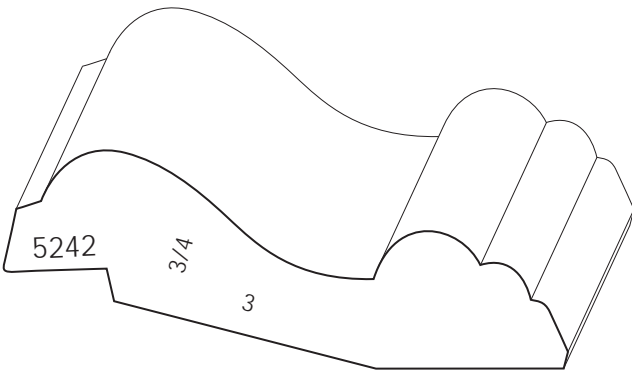
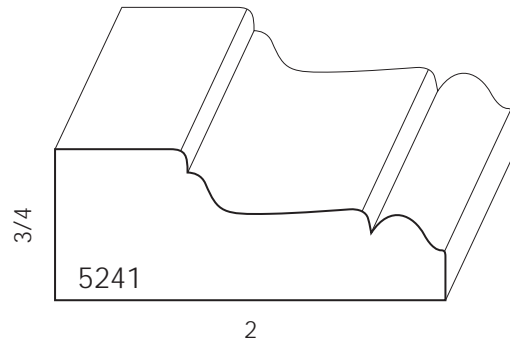
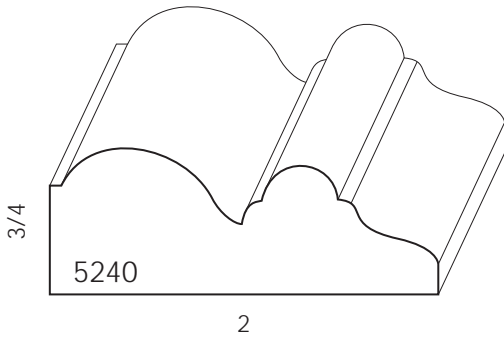
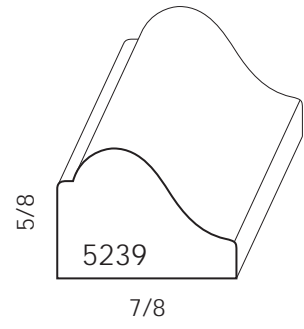
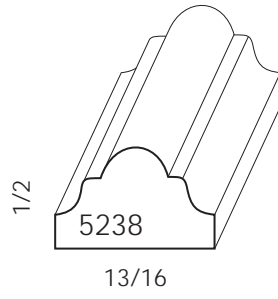
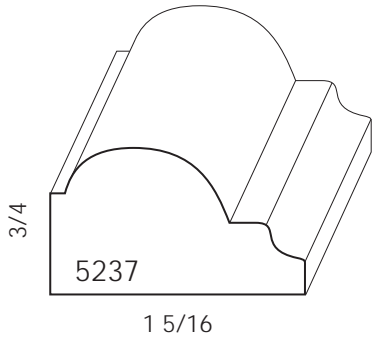

Panel Mold

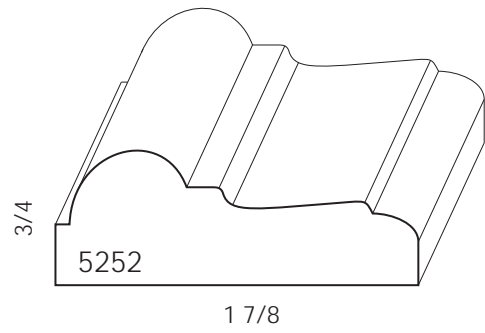
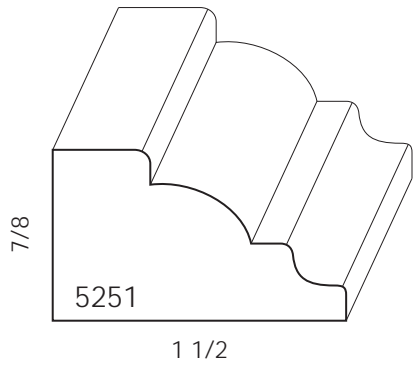
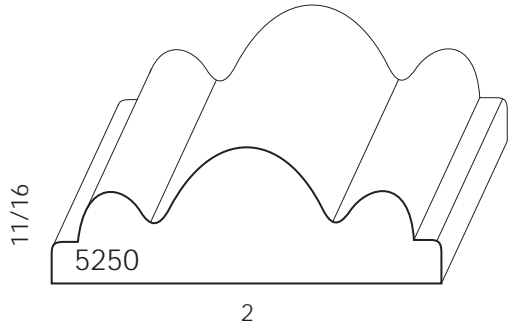
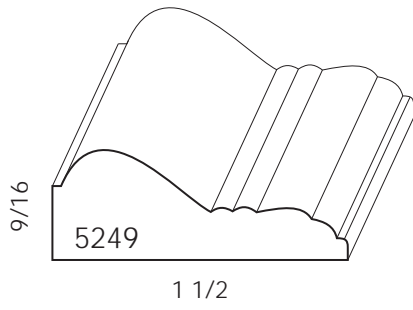
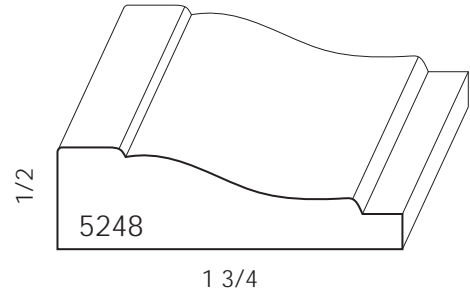
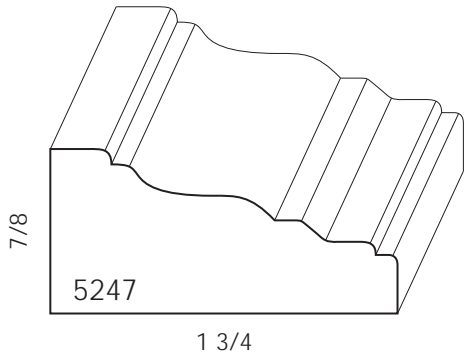

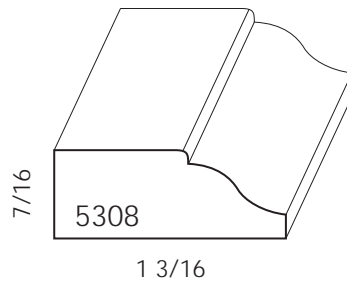
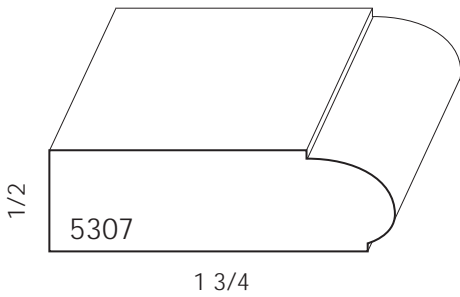
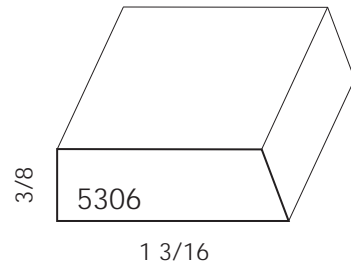
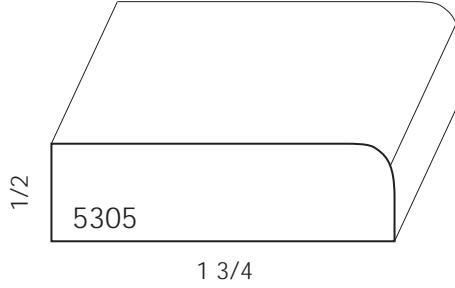
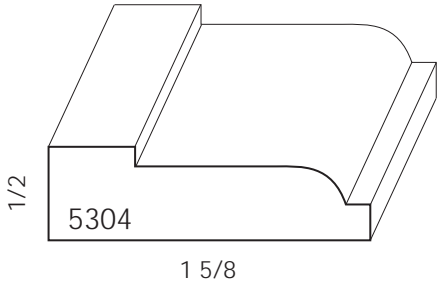
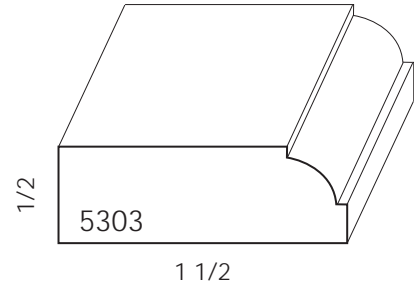
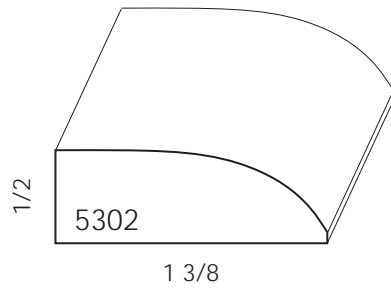
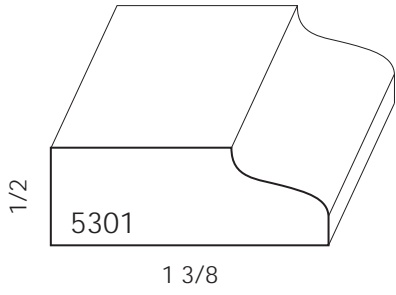

Base Cap

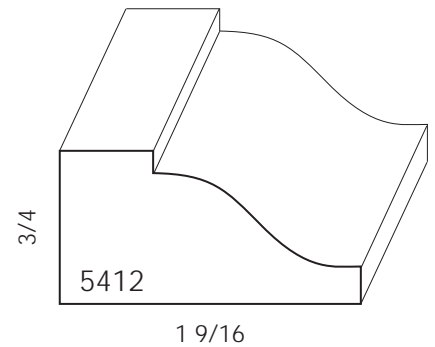
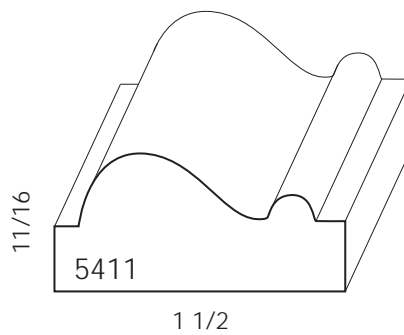
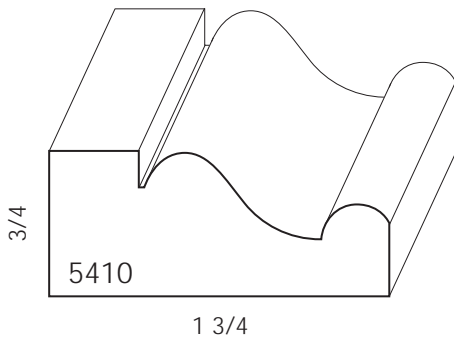
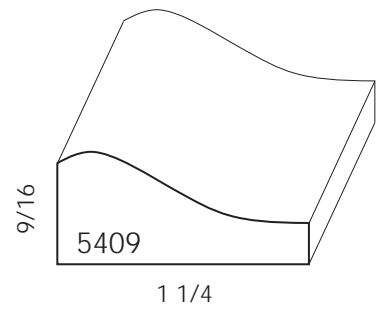
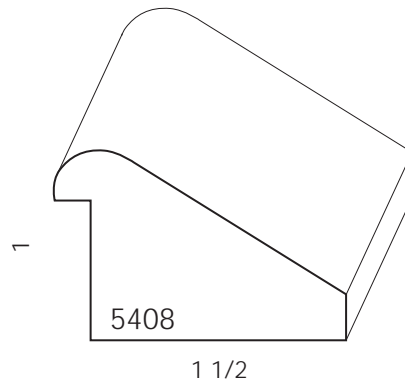
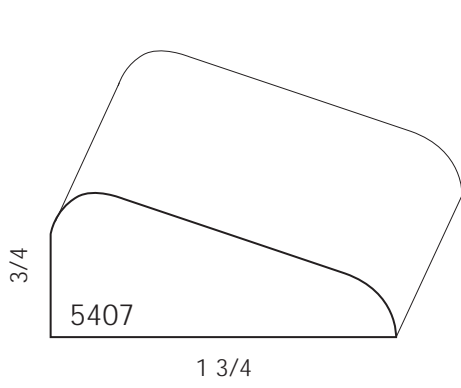
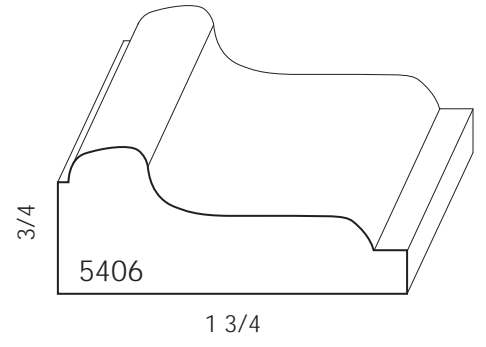
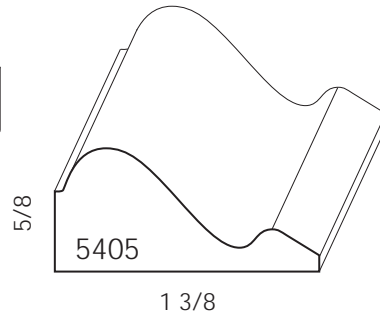
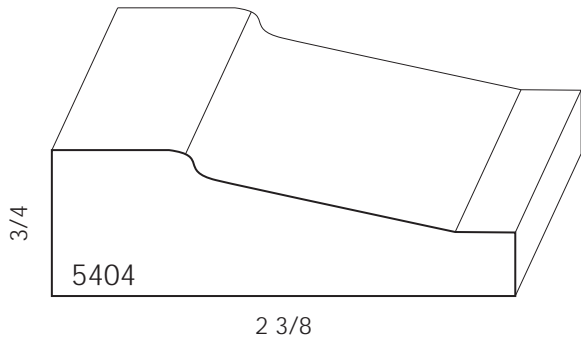
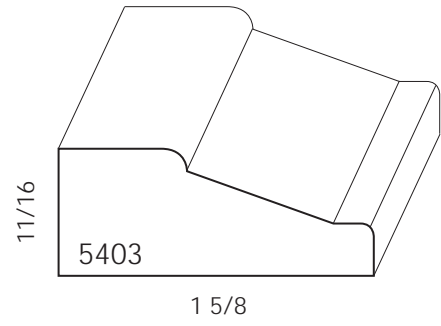
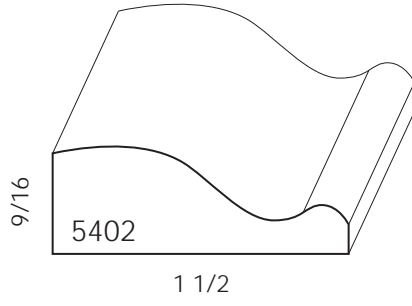
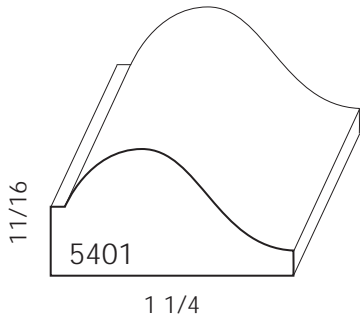

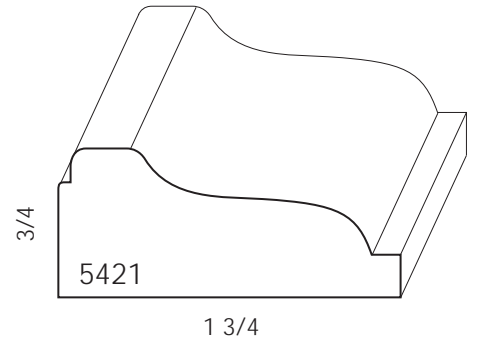
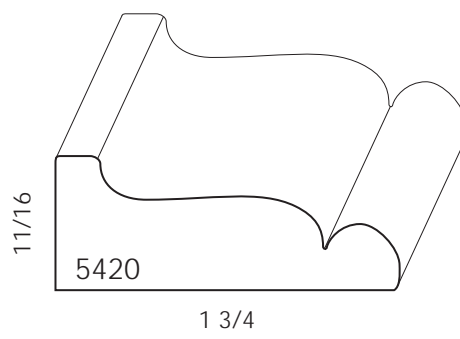
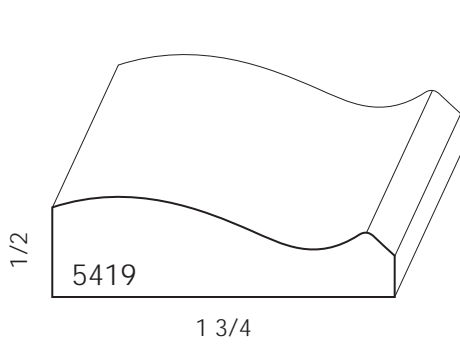
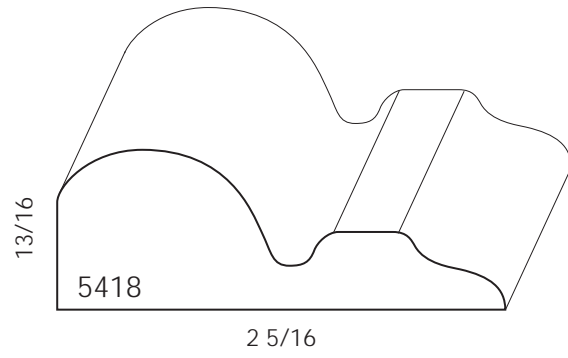
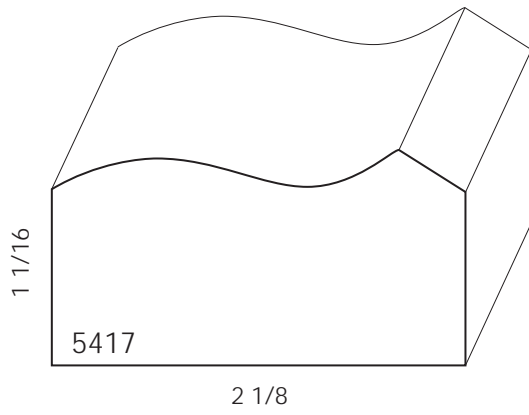
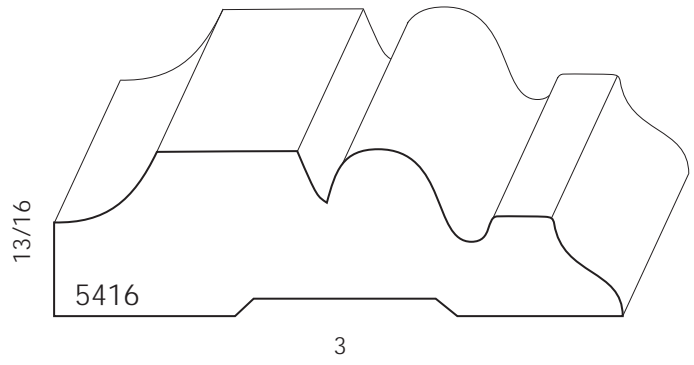
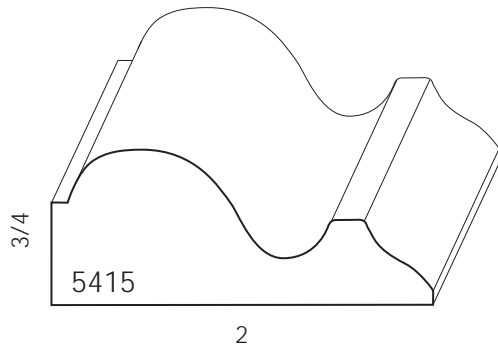
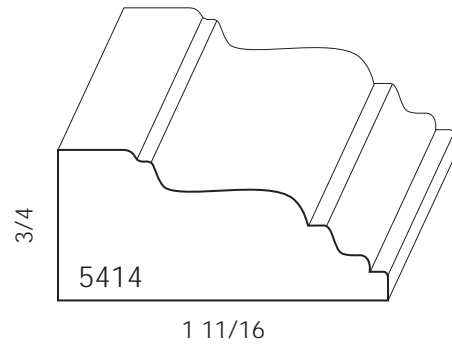
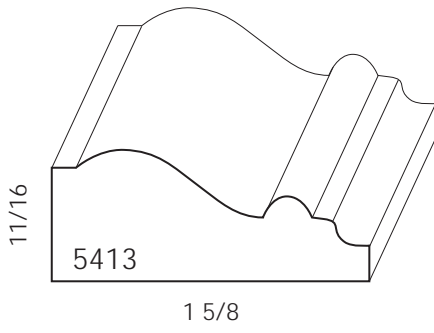

Base Cap

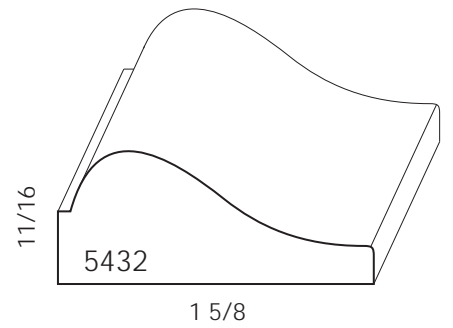
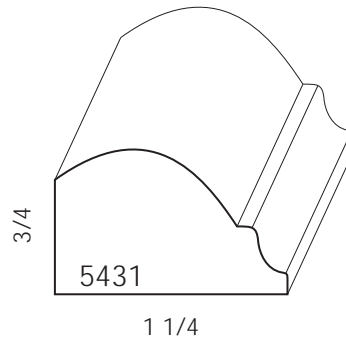
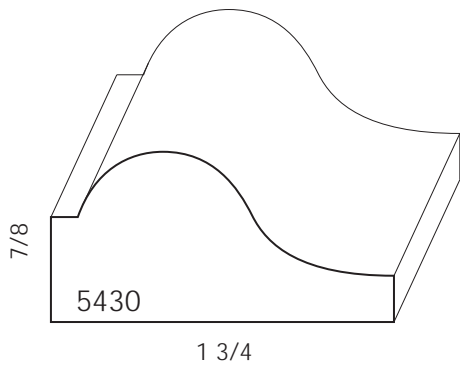
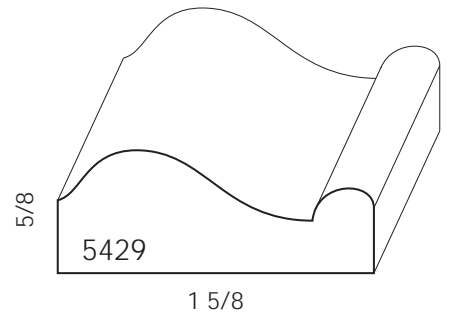
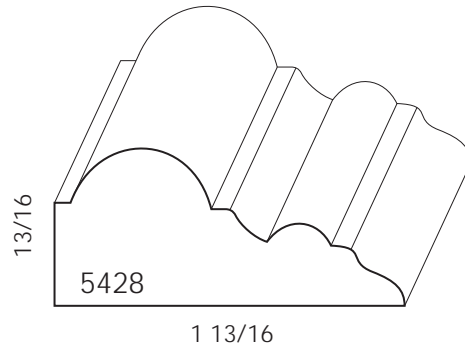
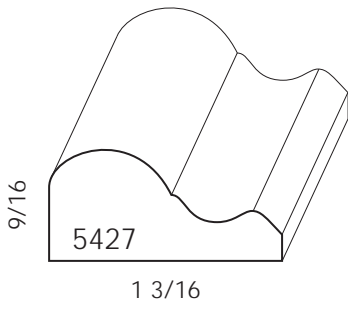
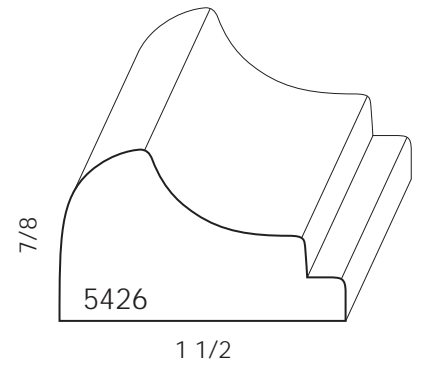
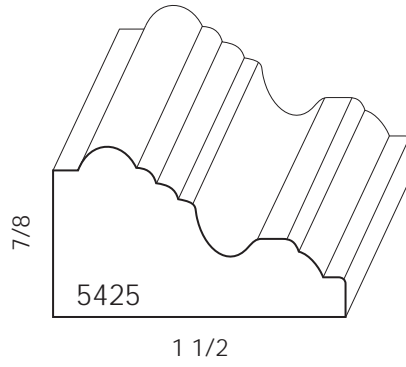
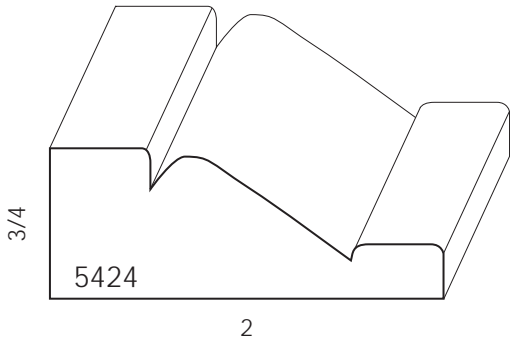
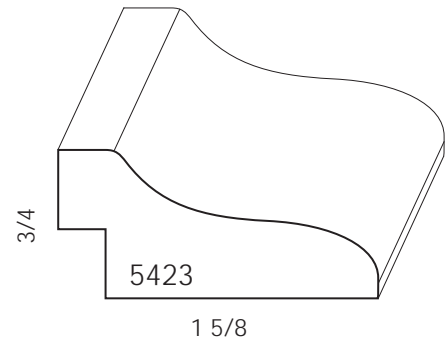
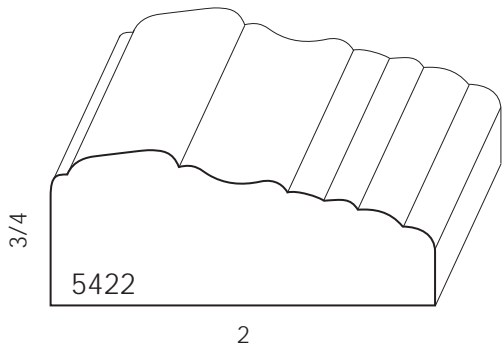

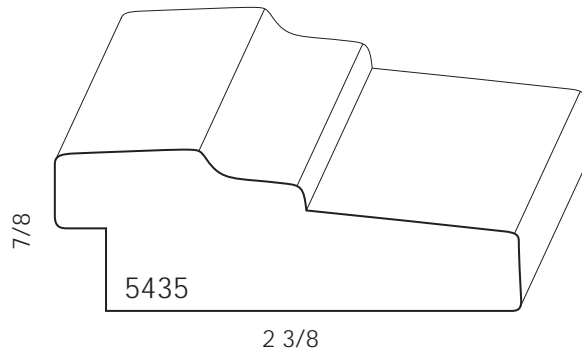
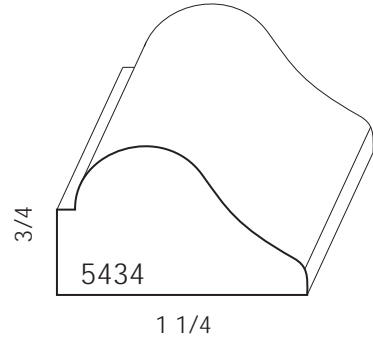
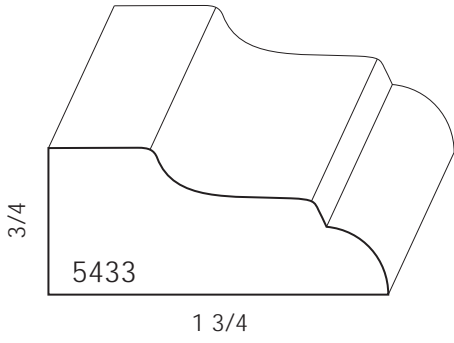

Outside Corner

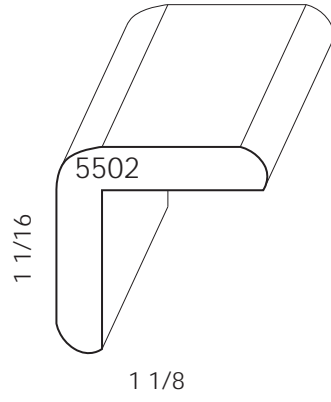
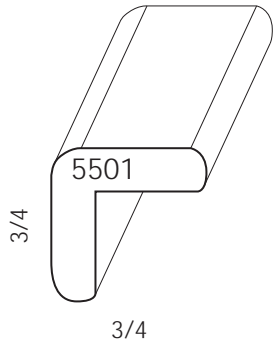

Handrail

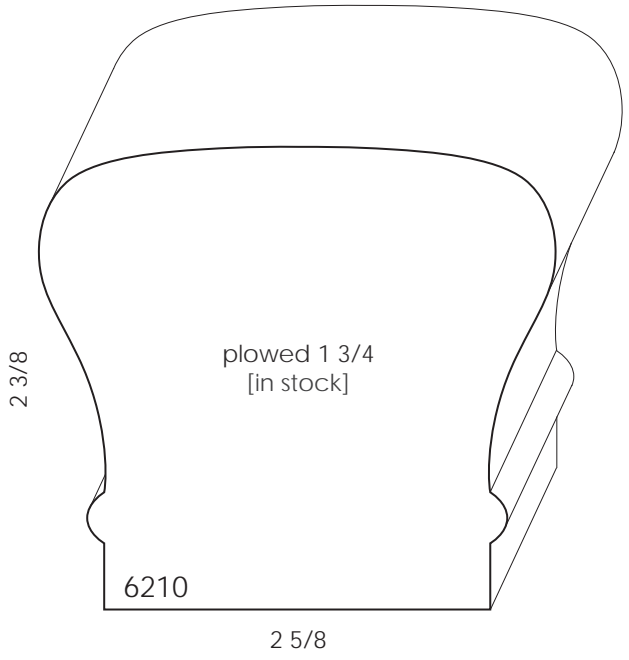
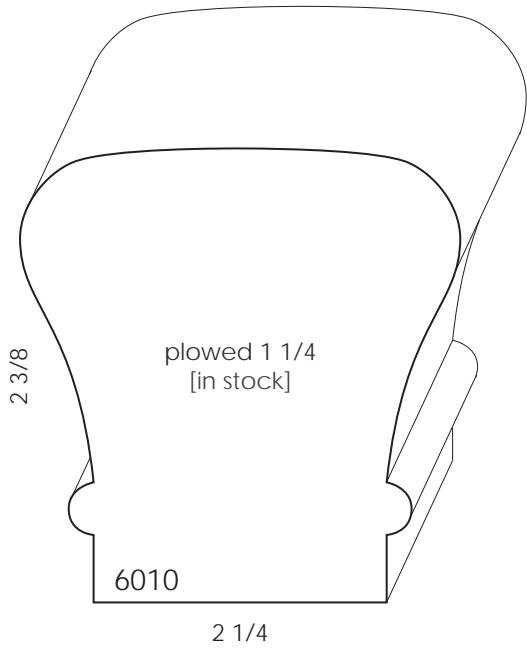

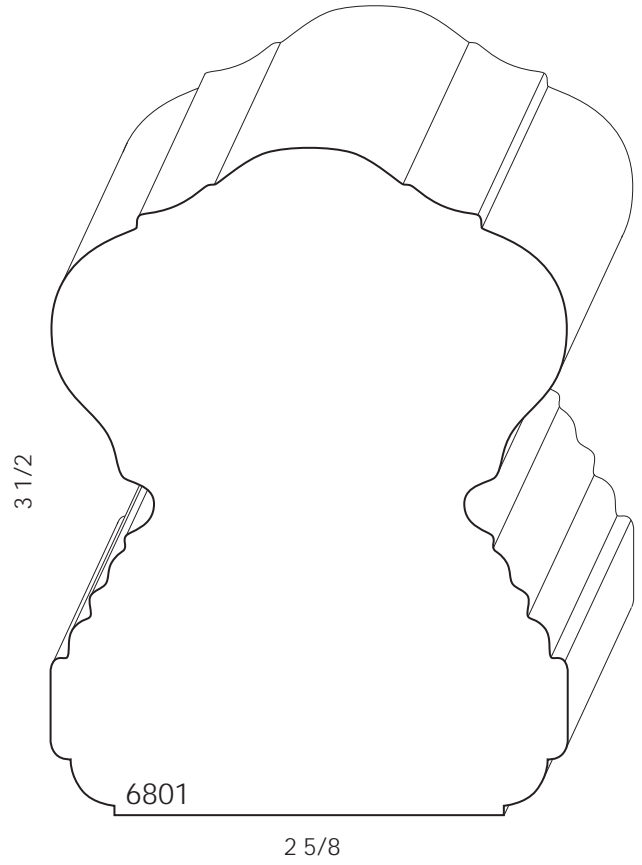
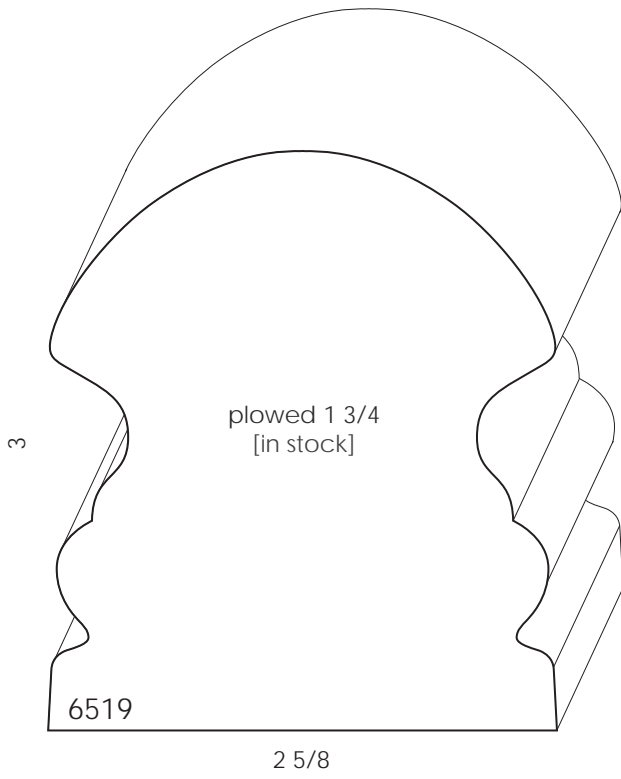

Handrails can be plowed for custom widths.

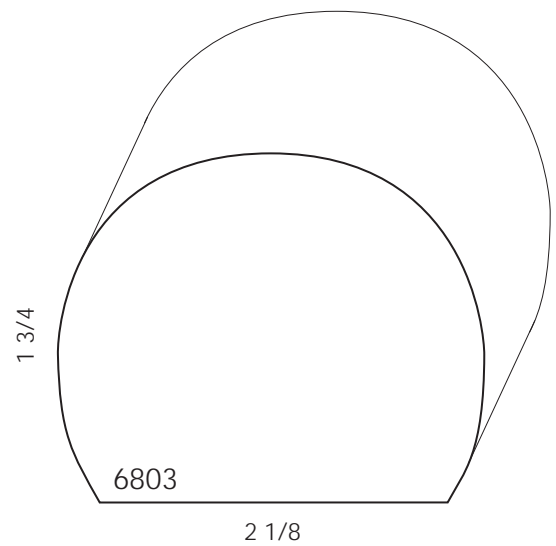
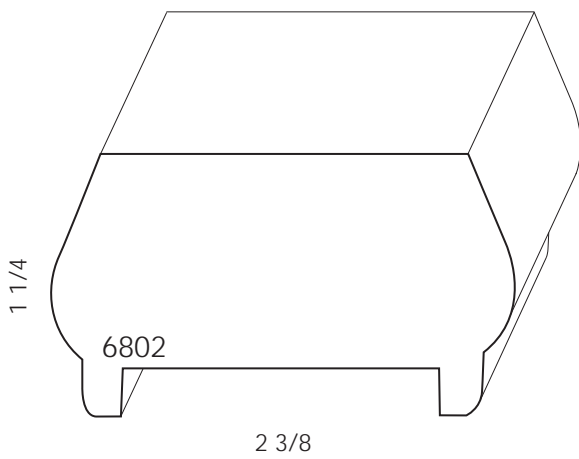

Handrail

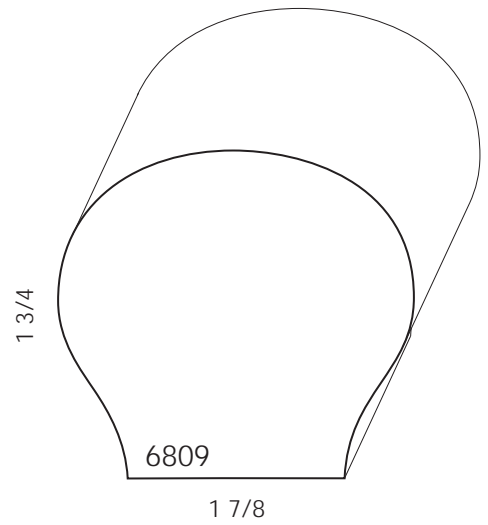
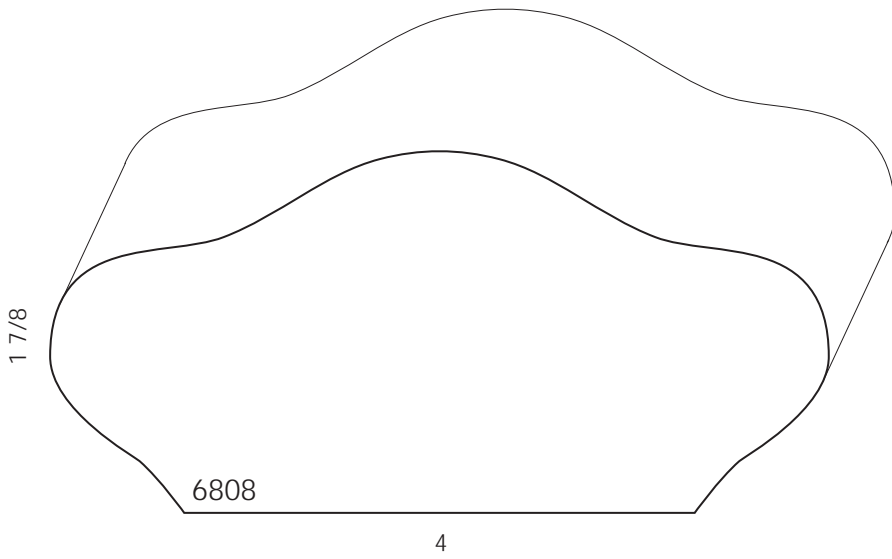
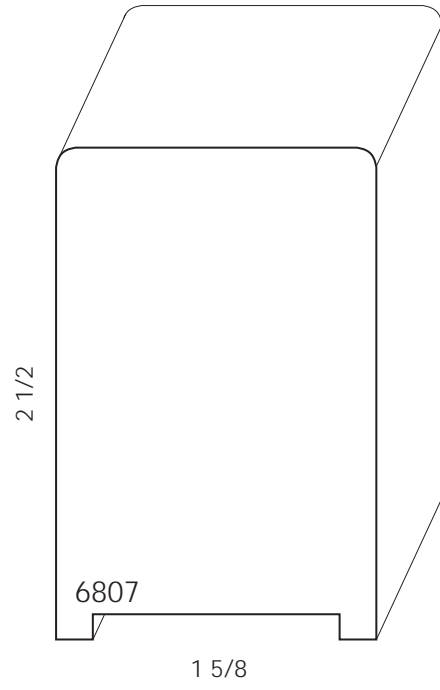
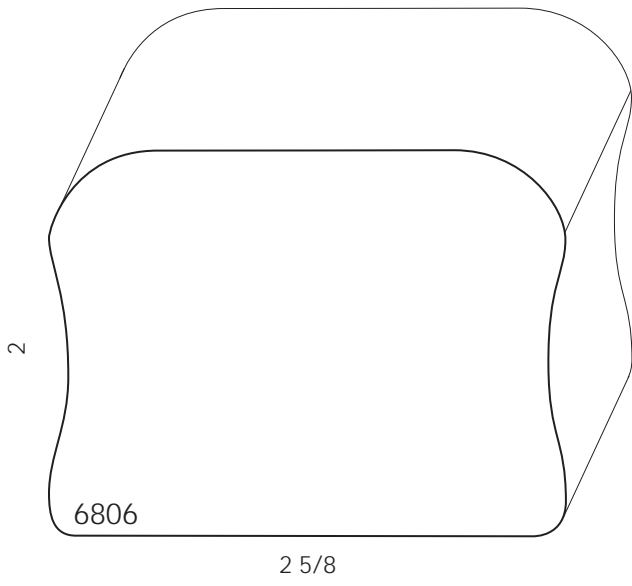
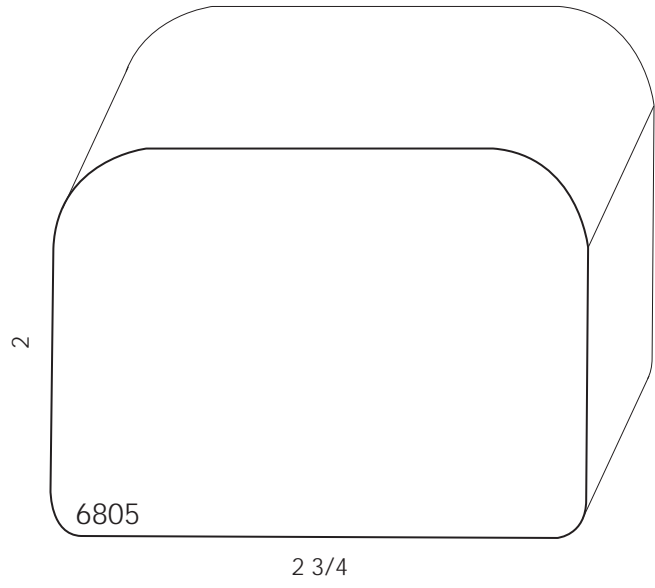
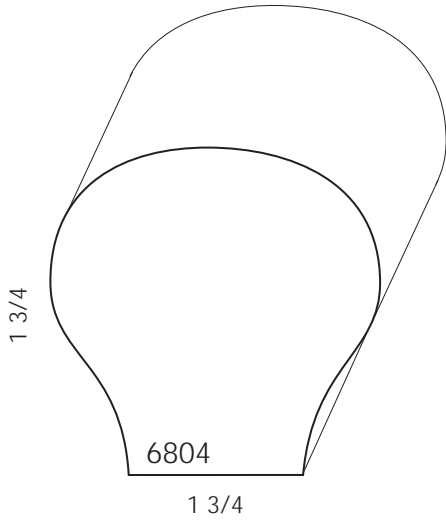

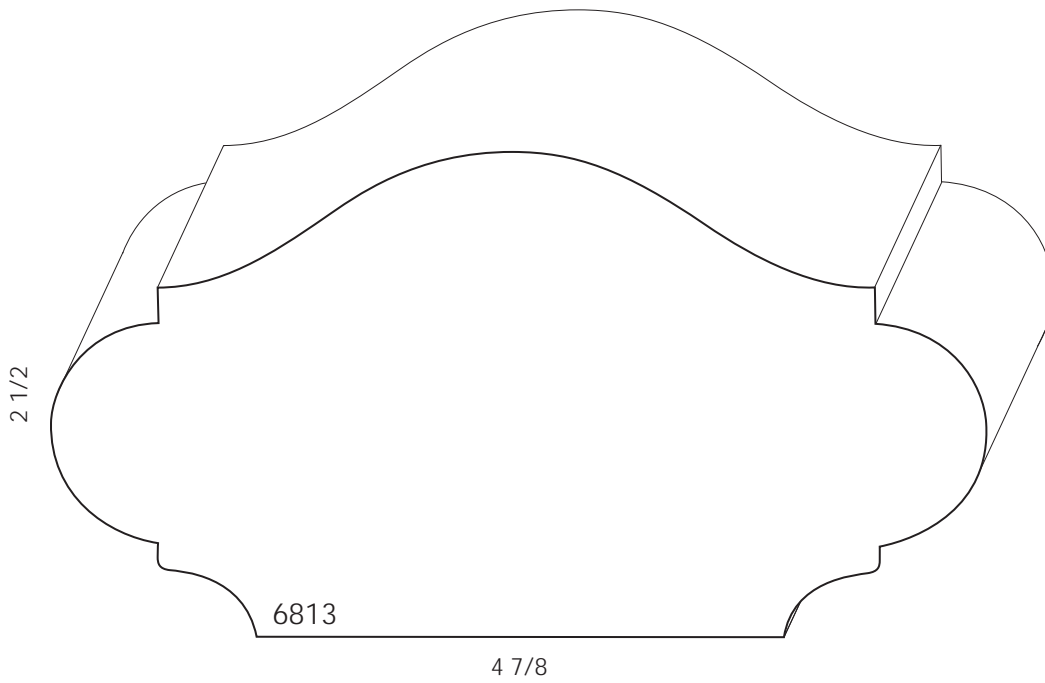
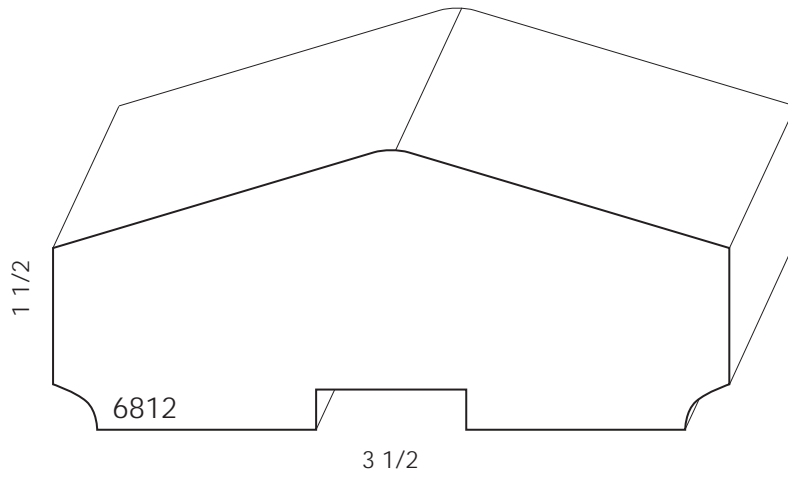
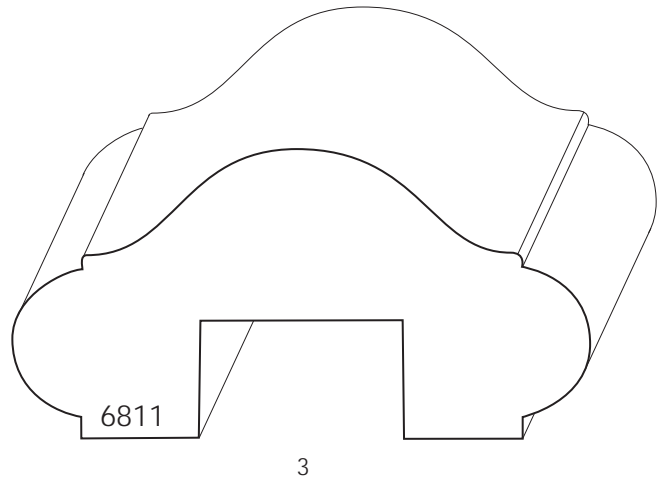
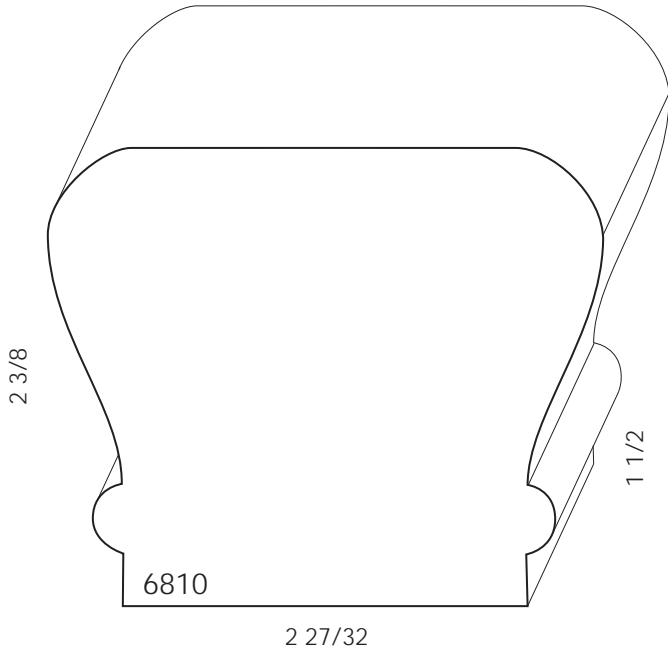

Handrail

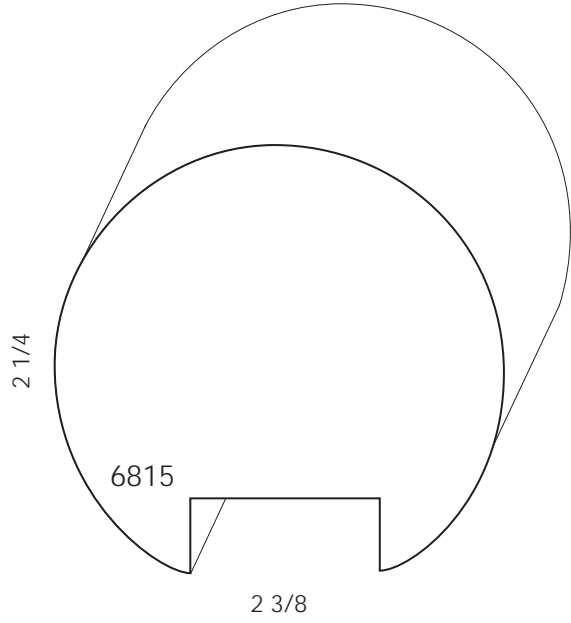
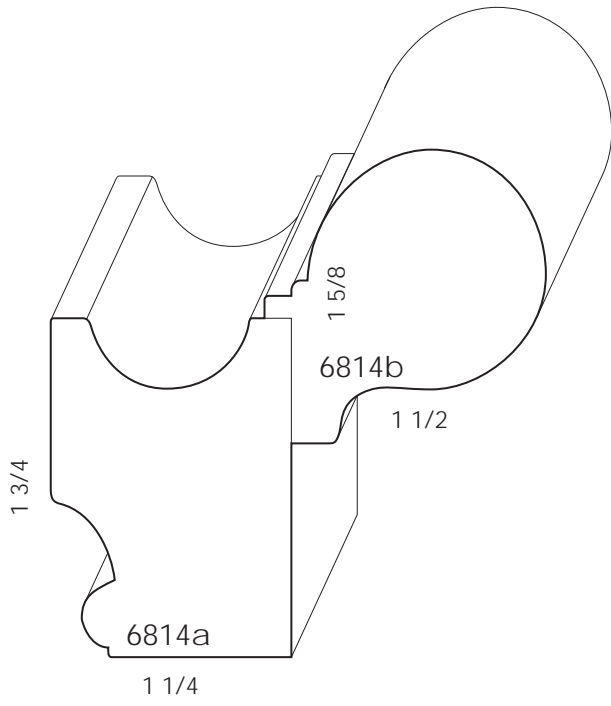

Handrails can be plowed for custom widths.

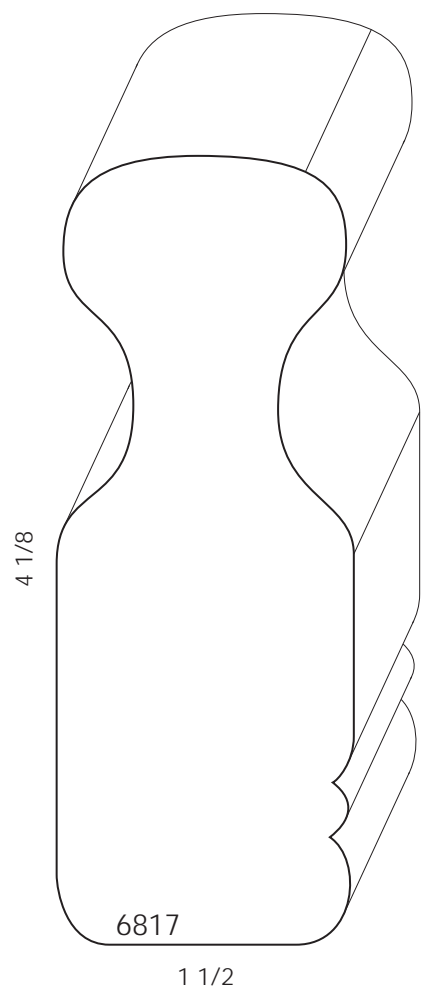
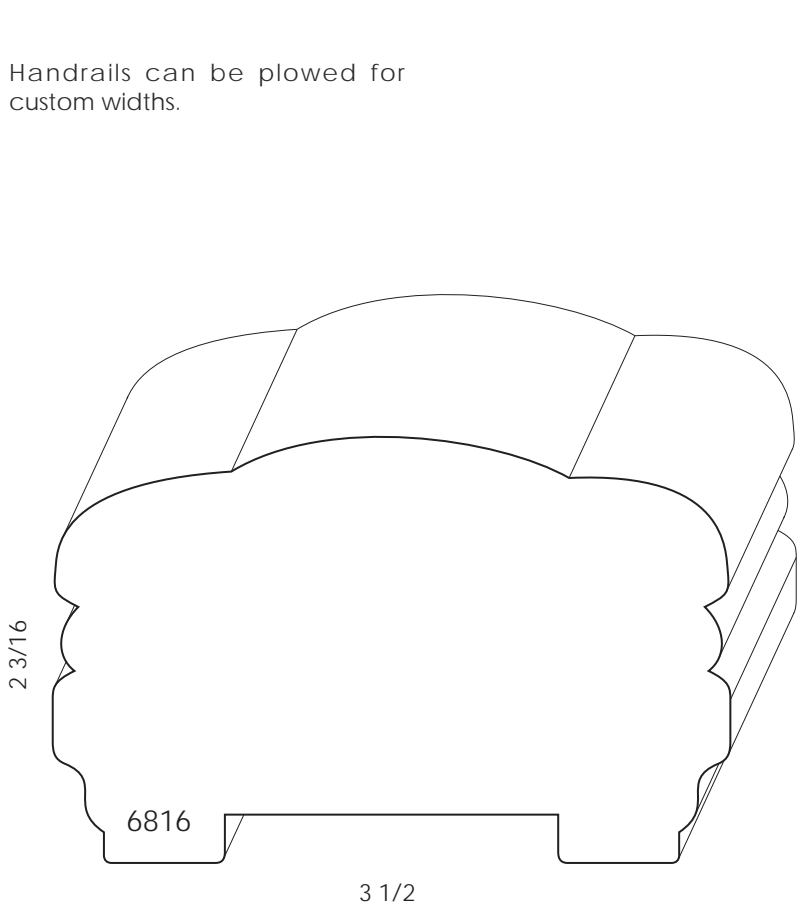

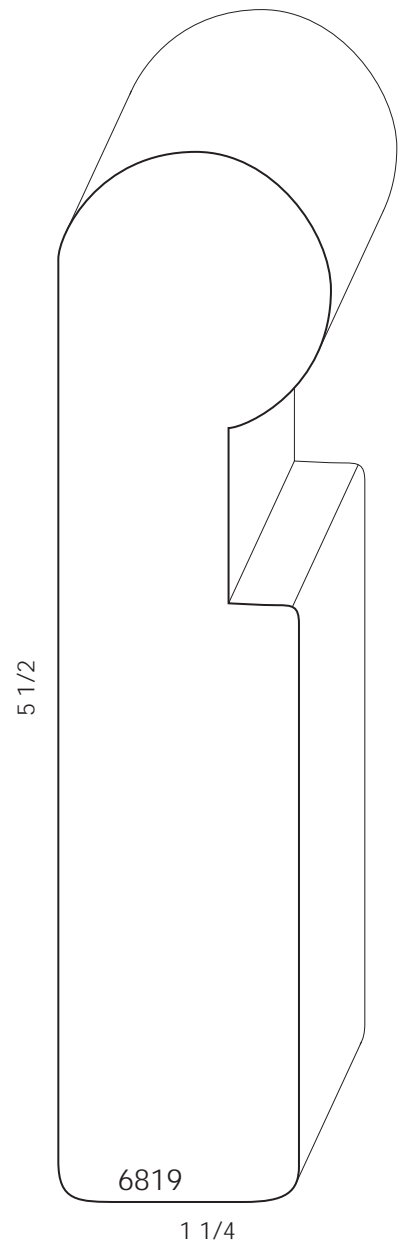
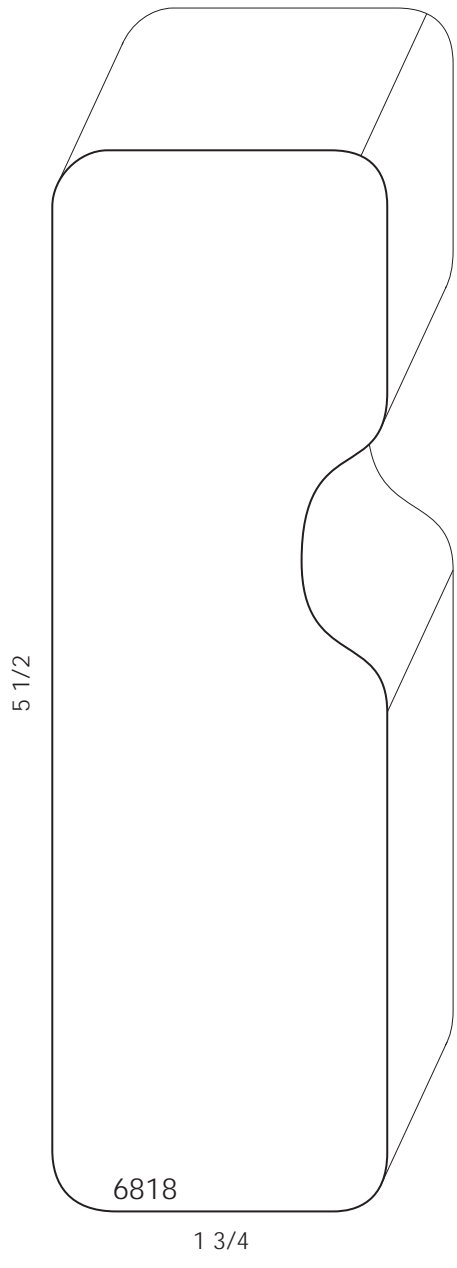

Shoerail

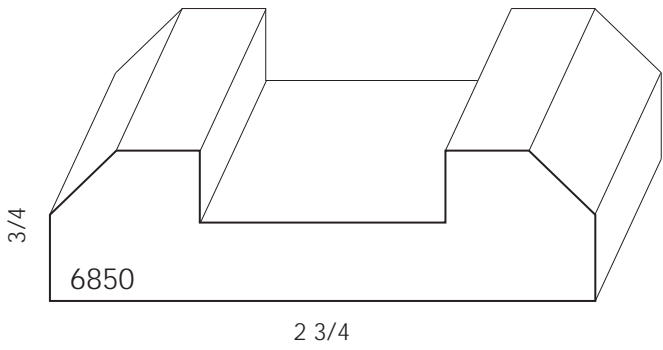
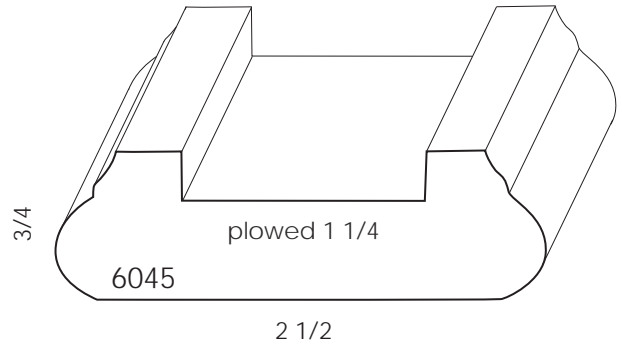
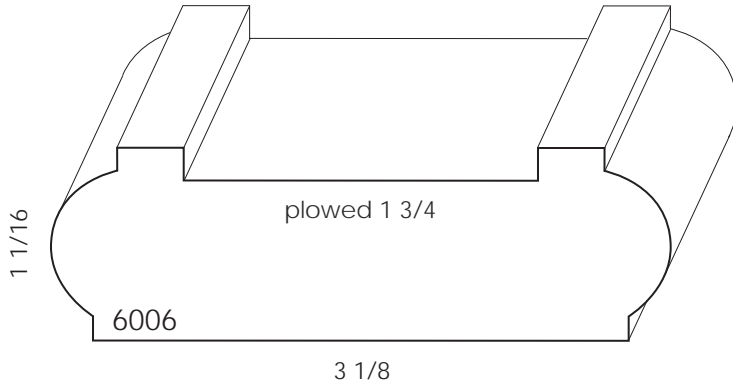

Shoerails can be plowed for custom widths.

Fillet

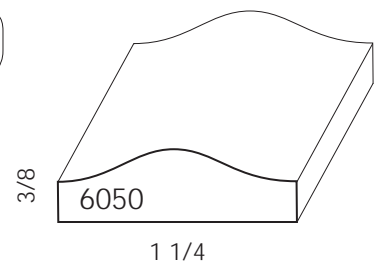
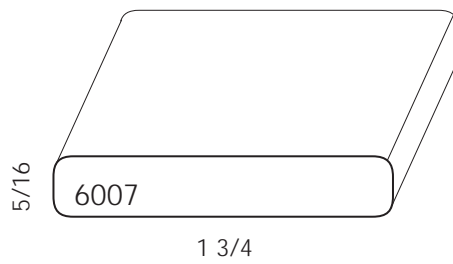
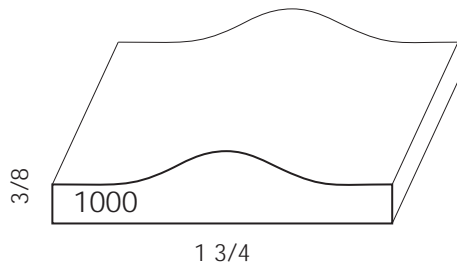

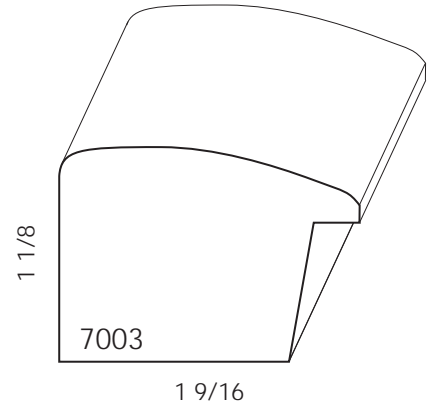
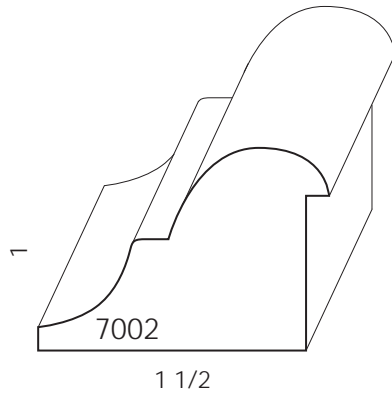
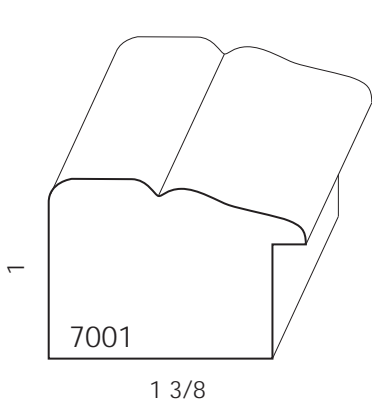

Backband height can be modified to match casing dimensions.

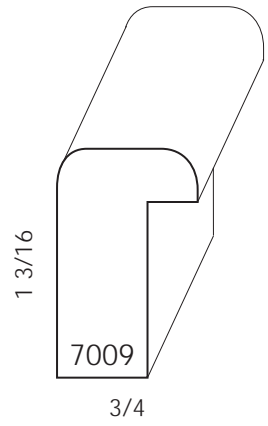
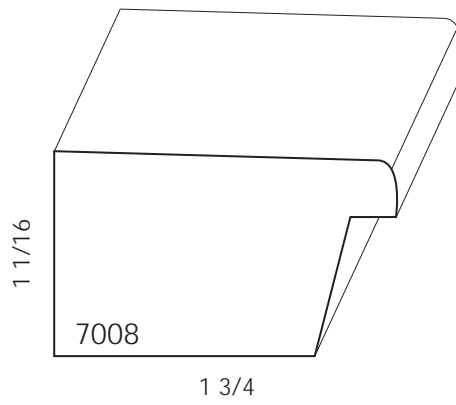
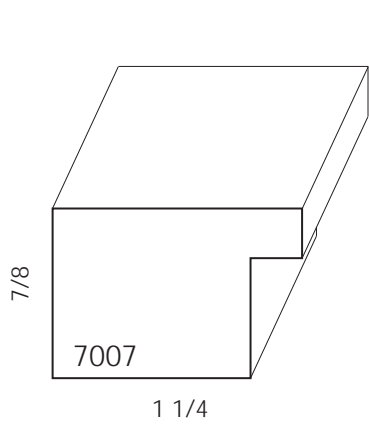
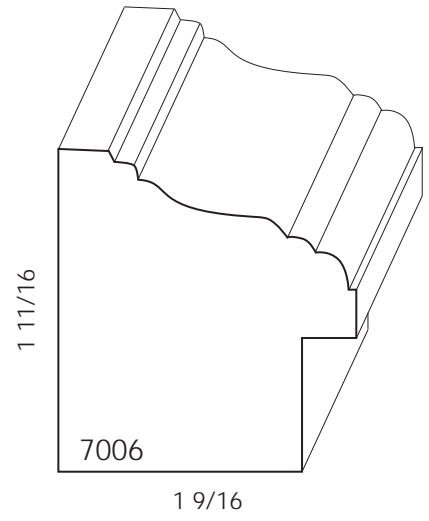
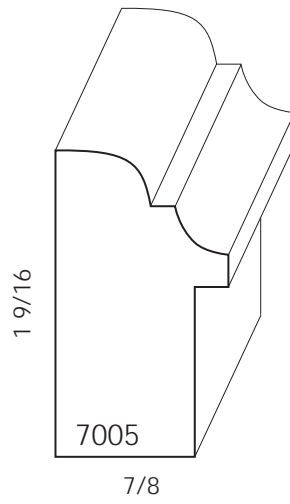
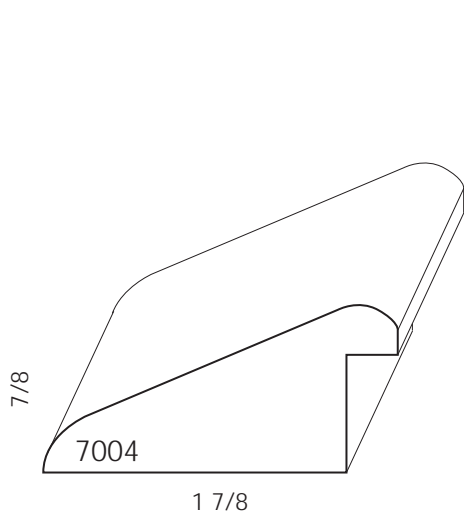

Back Band

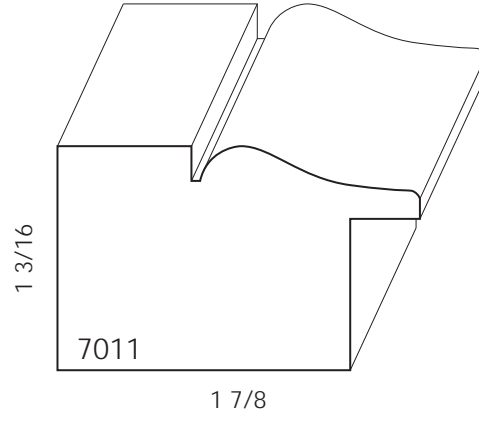
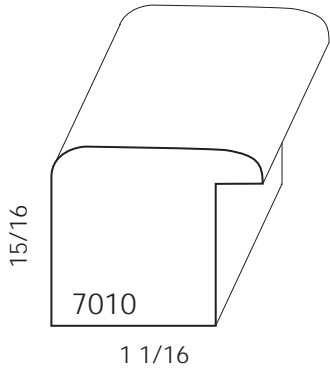

Backband height can be modified to match casing dimensions.

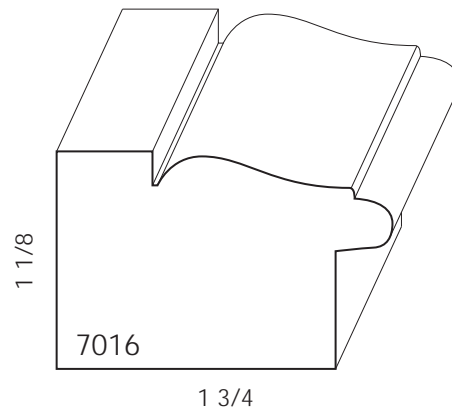
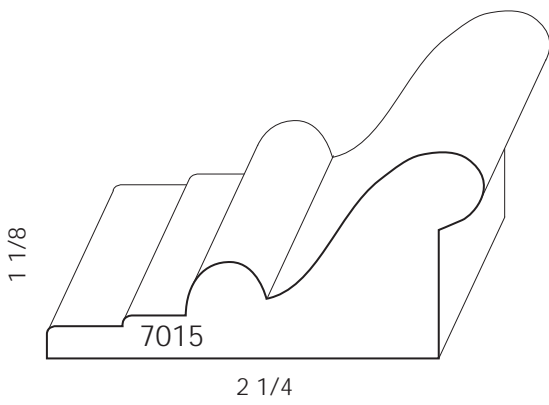
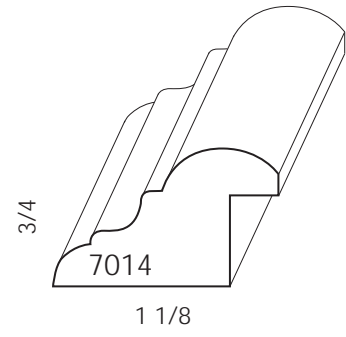
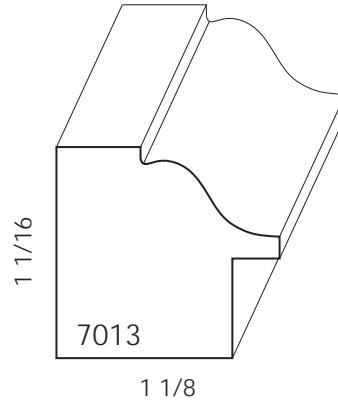
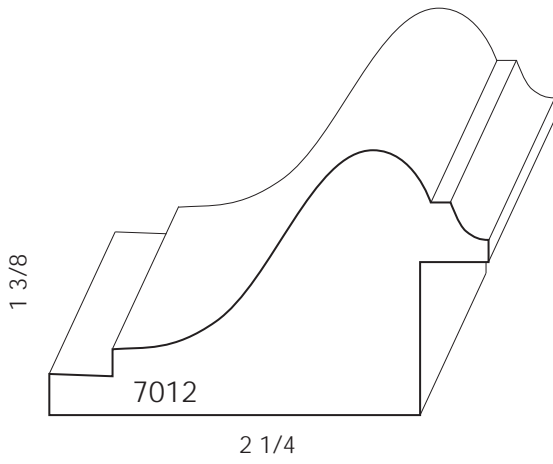

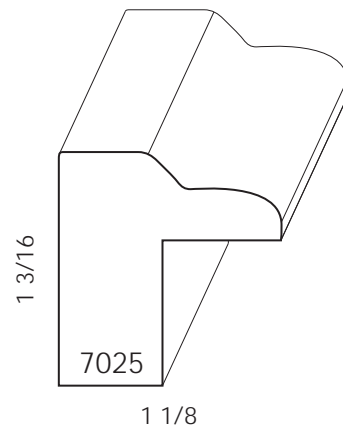
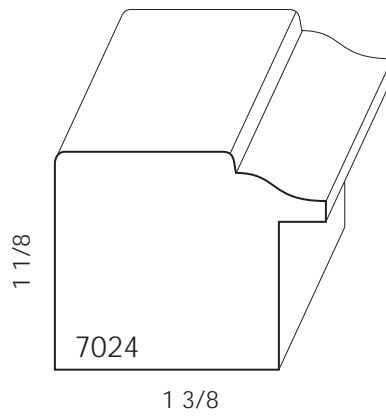
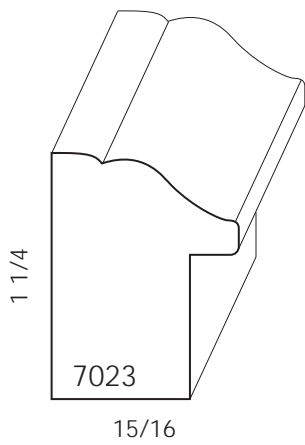
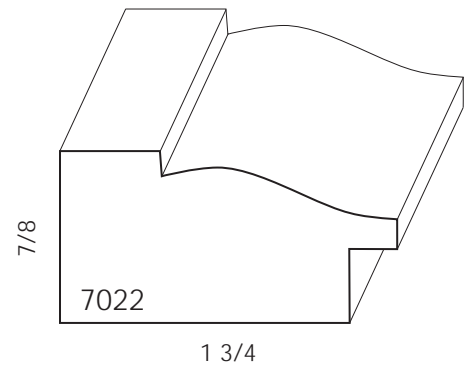
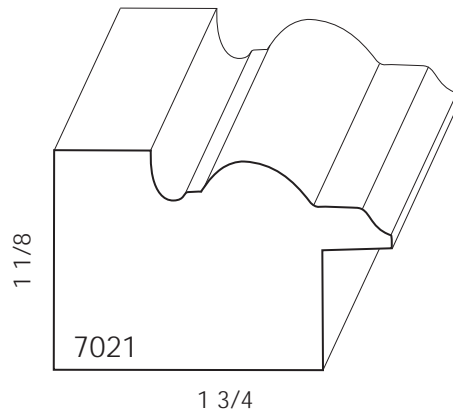
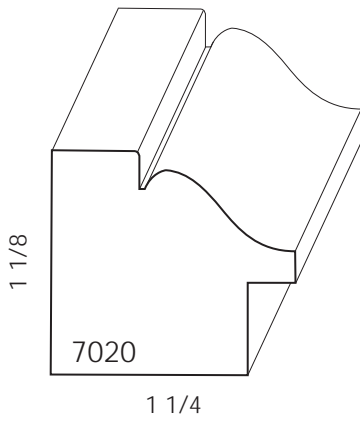
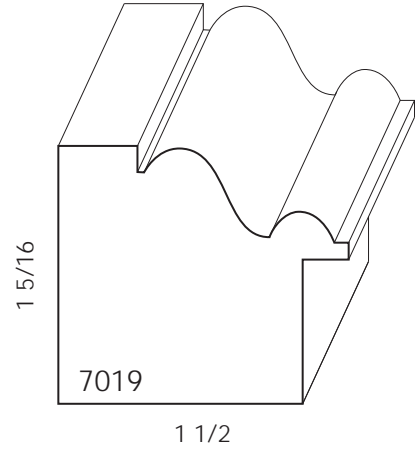
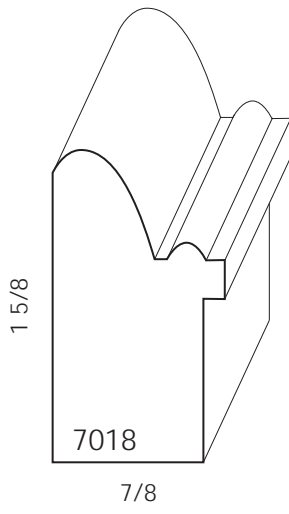
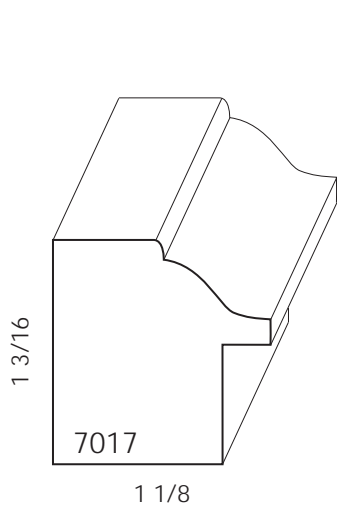

Back Band

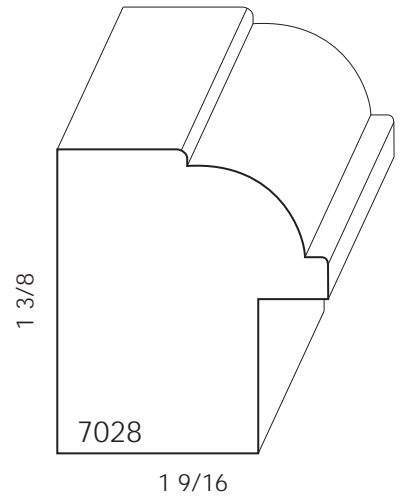
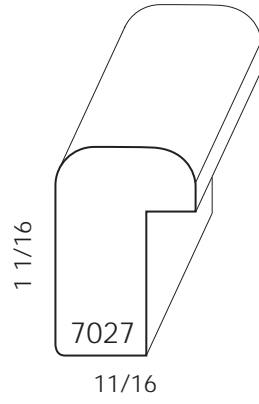
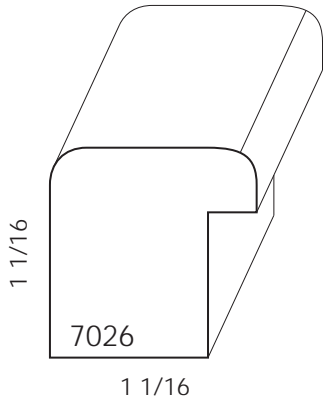

Backband height can be modified to match casing dimensions.

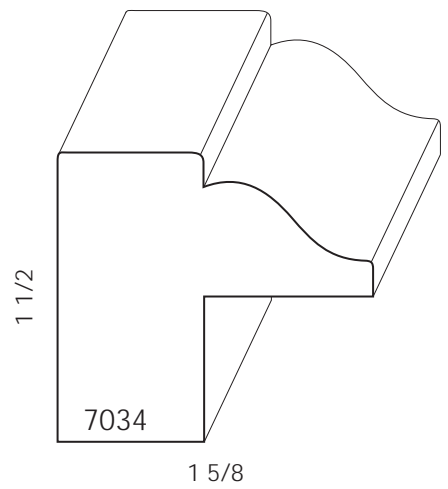
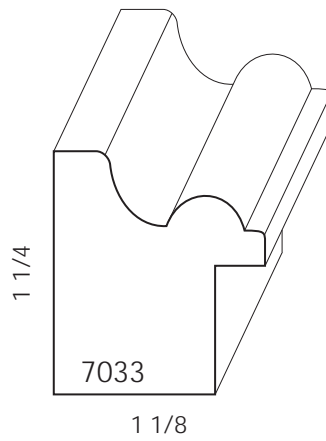
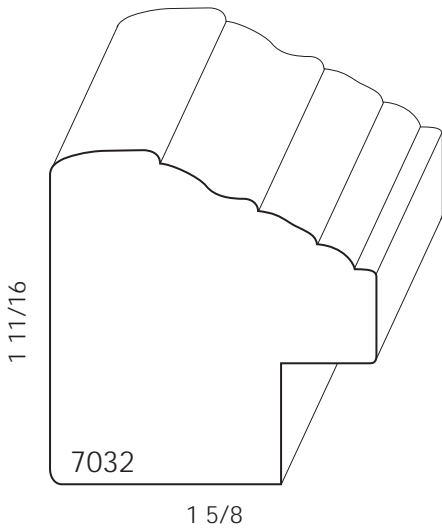
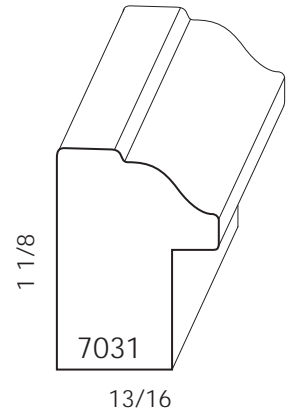
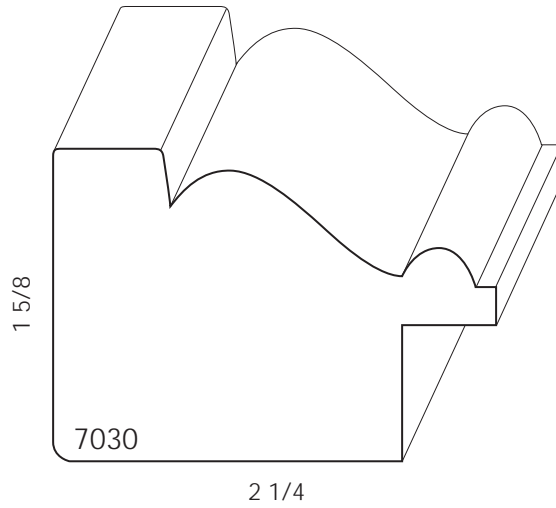
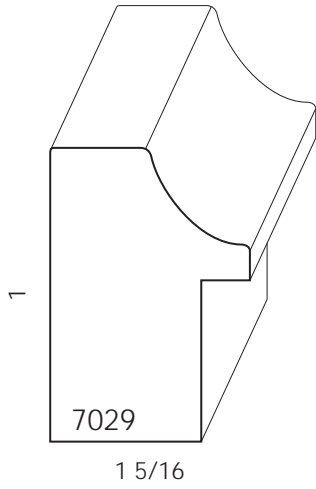

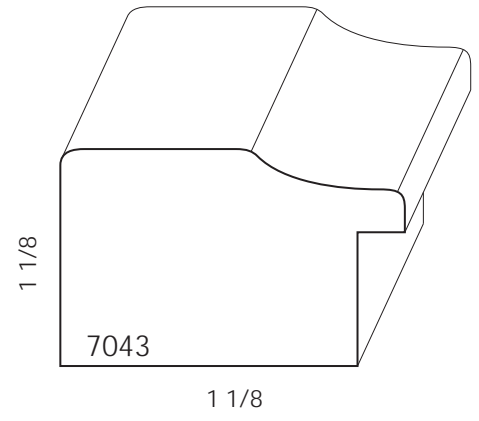
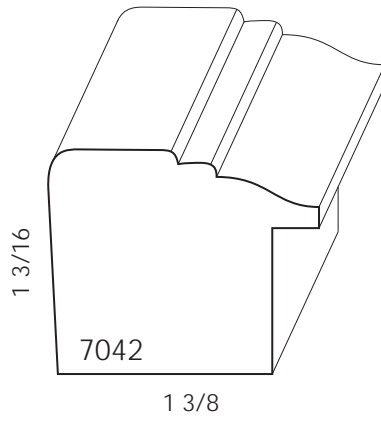
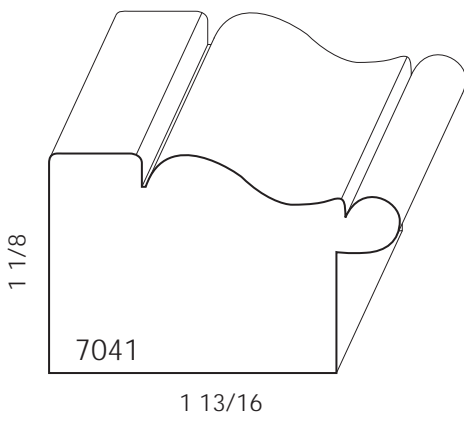
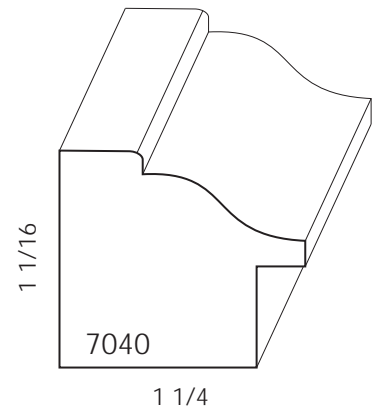
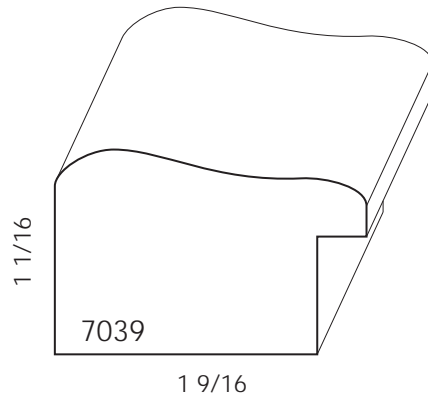
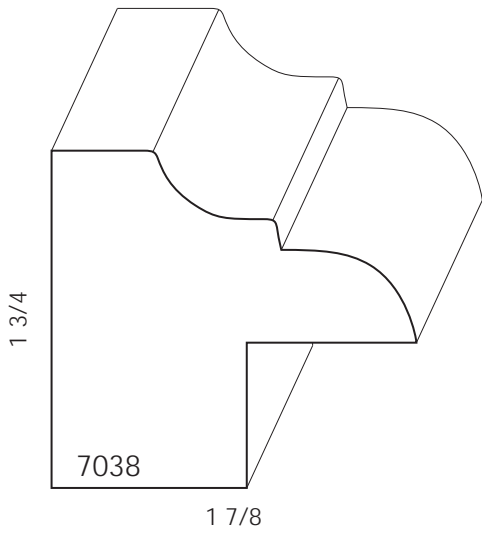
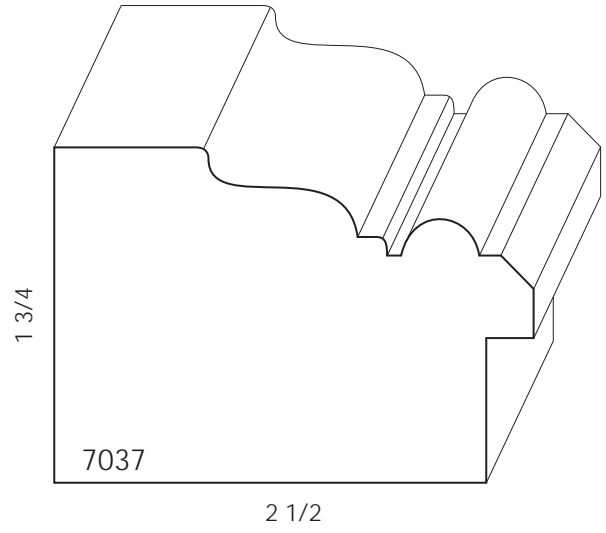
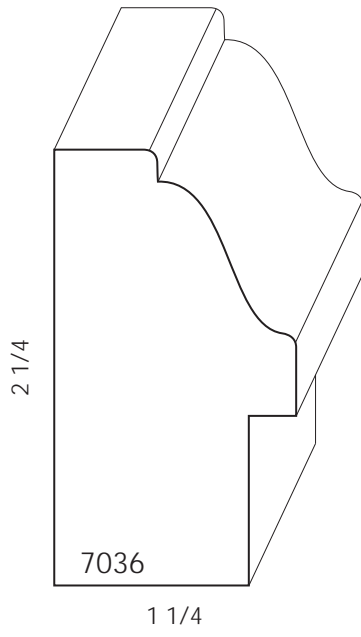
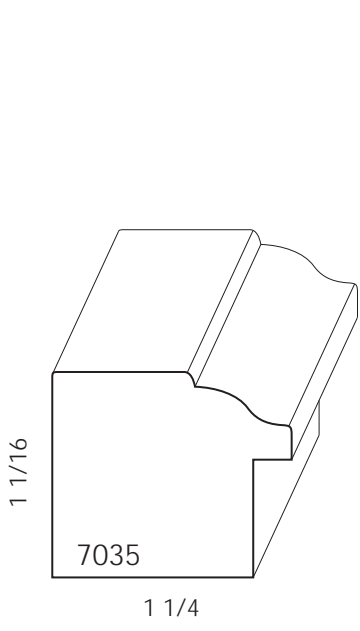

Back Band

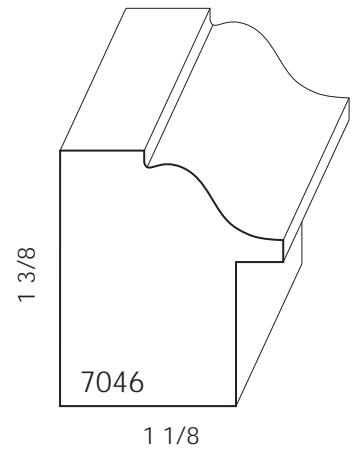
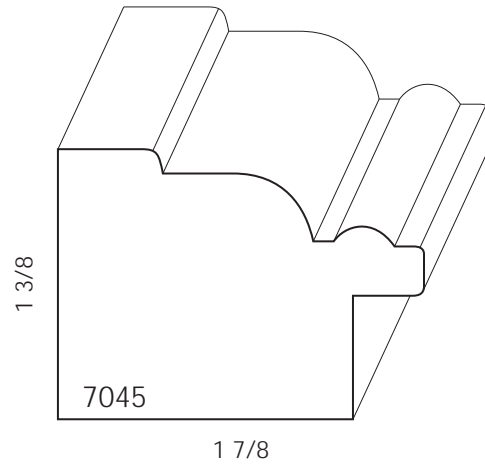
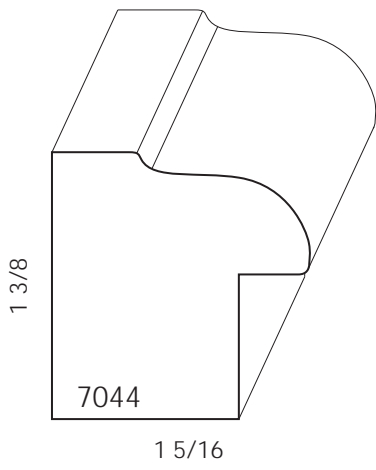

Backband height can be modified to match casing dimensions.

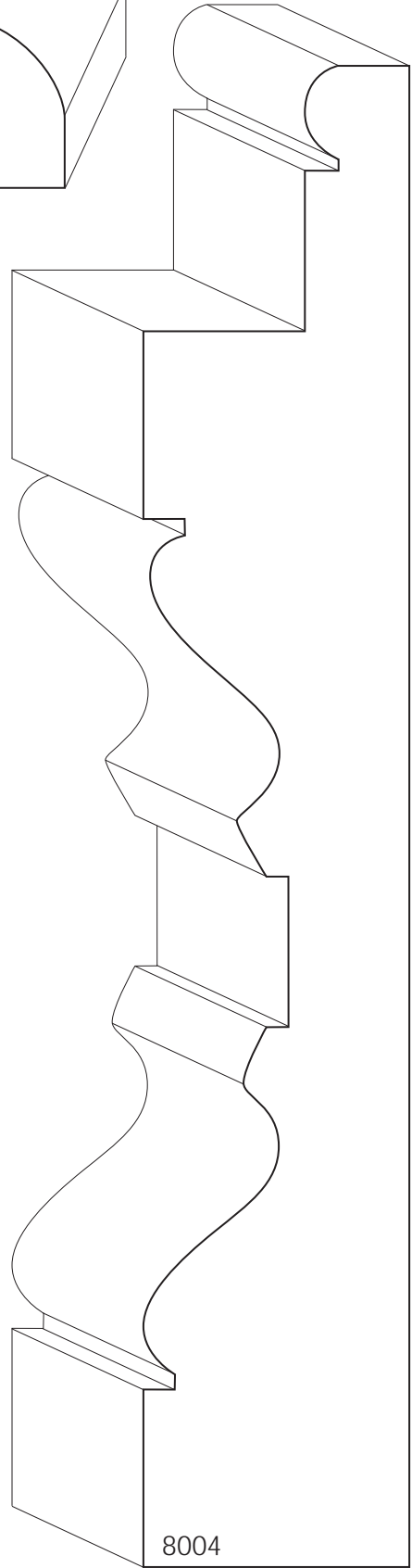
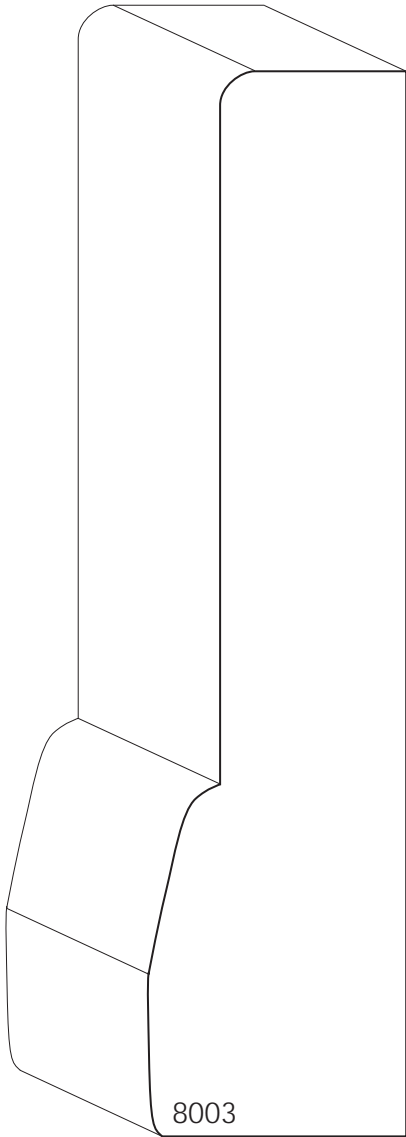
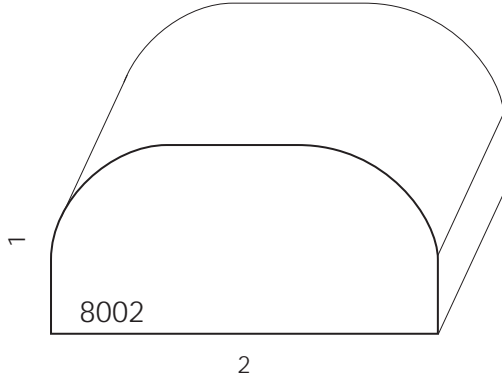
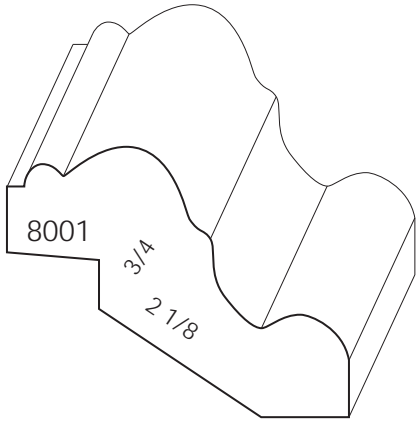

1 5/16

1 1/2

Miscellaneous

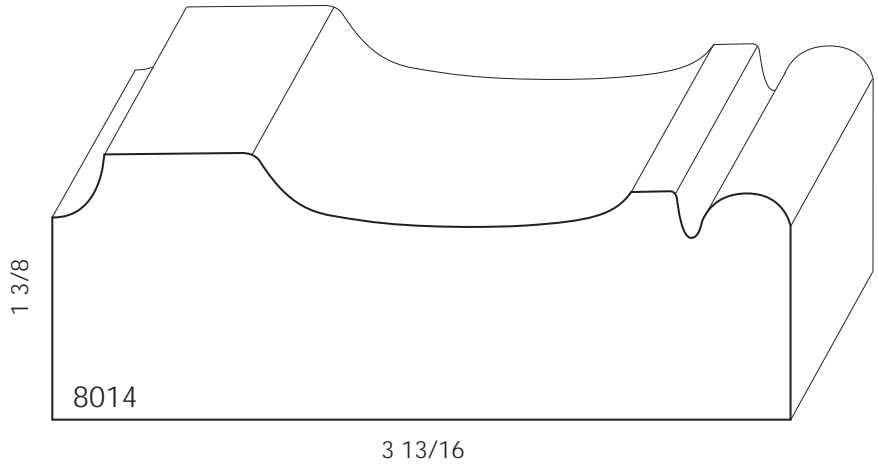
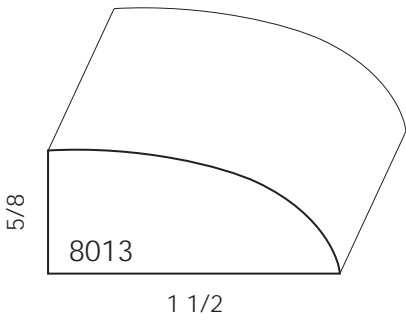
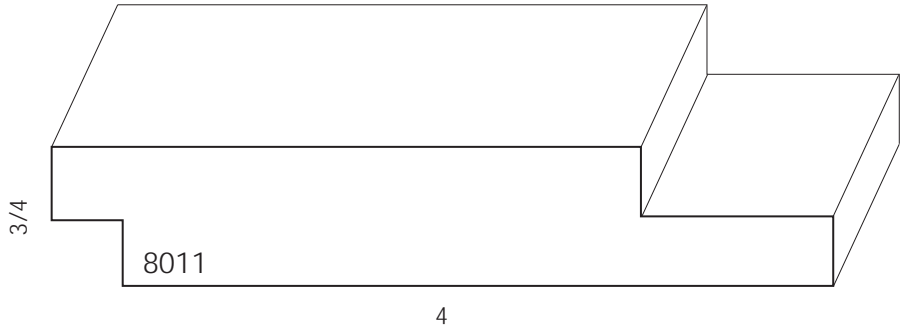
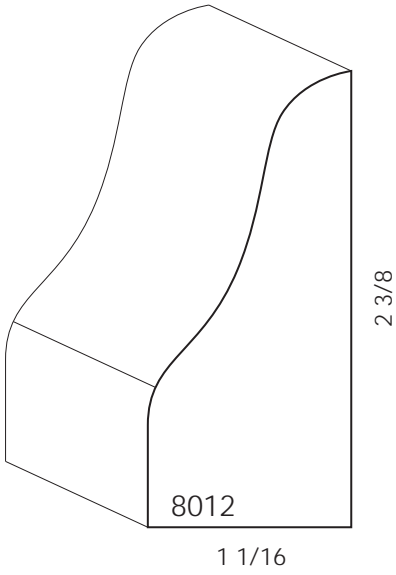
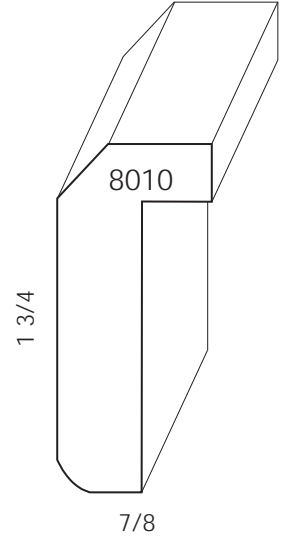
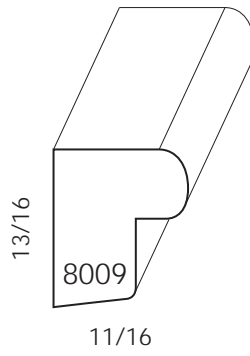
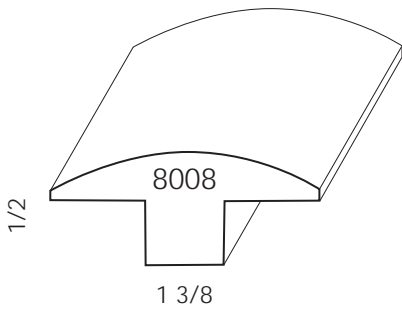
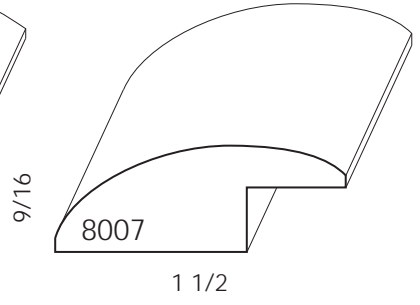
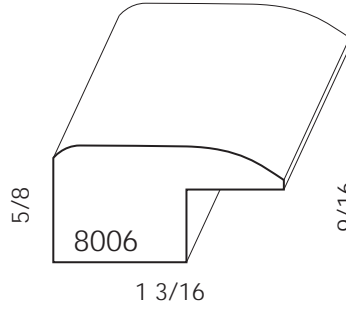
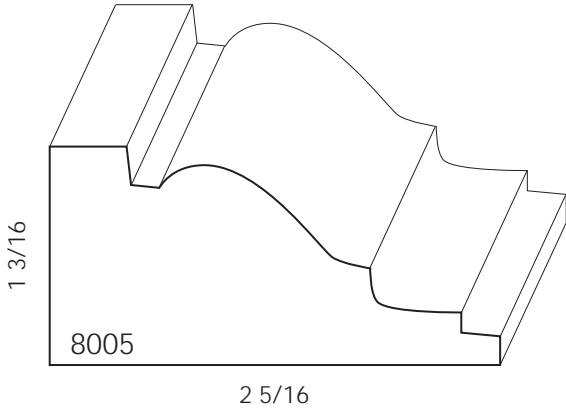

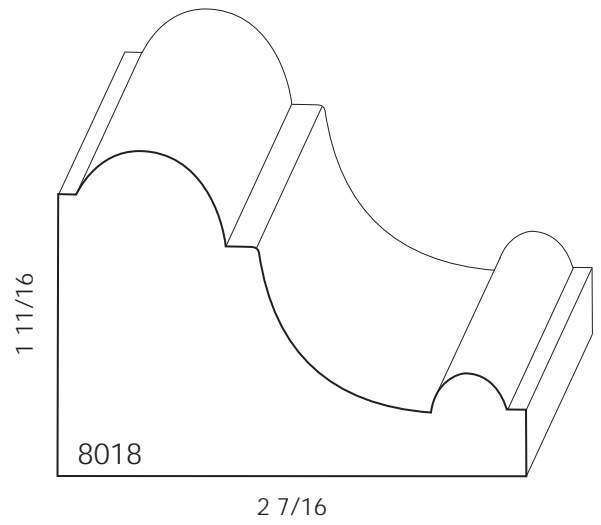
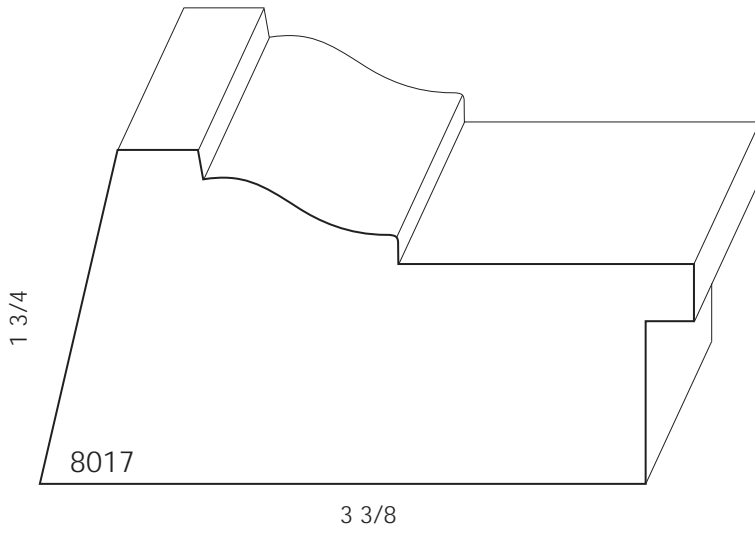
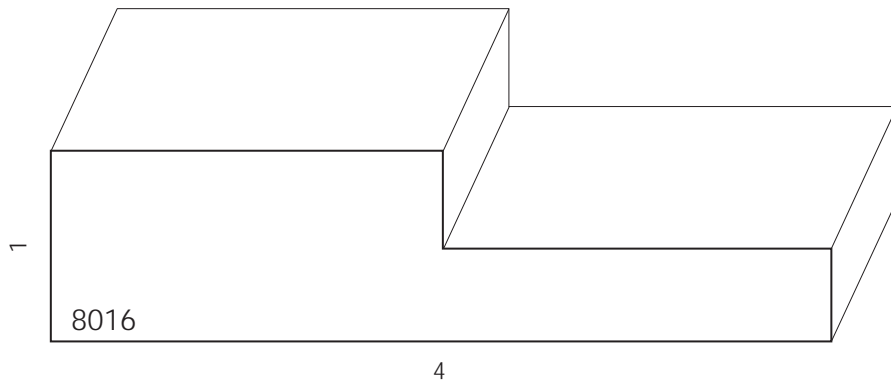
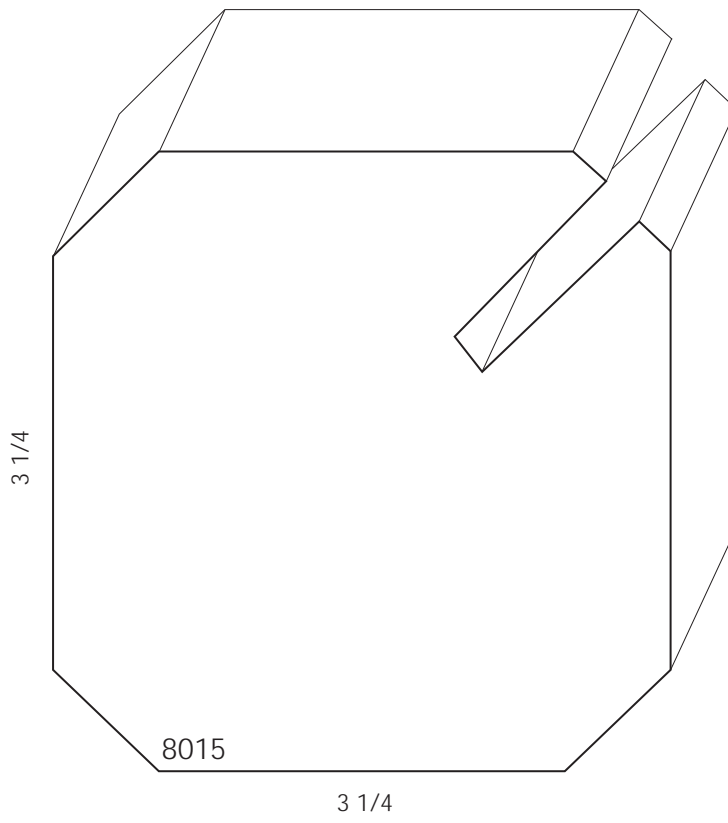

Miscellaneous

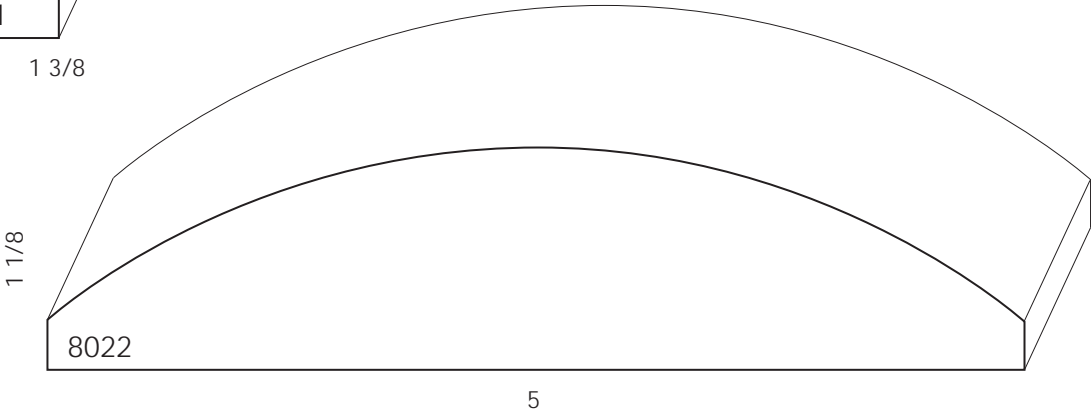
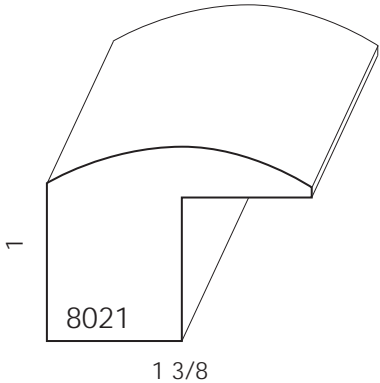
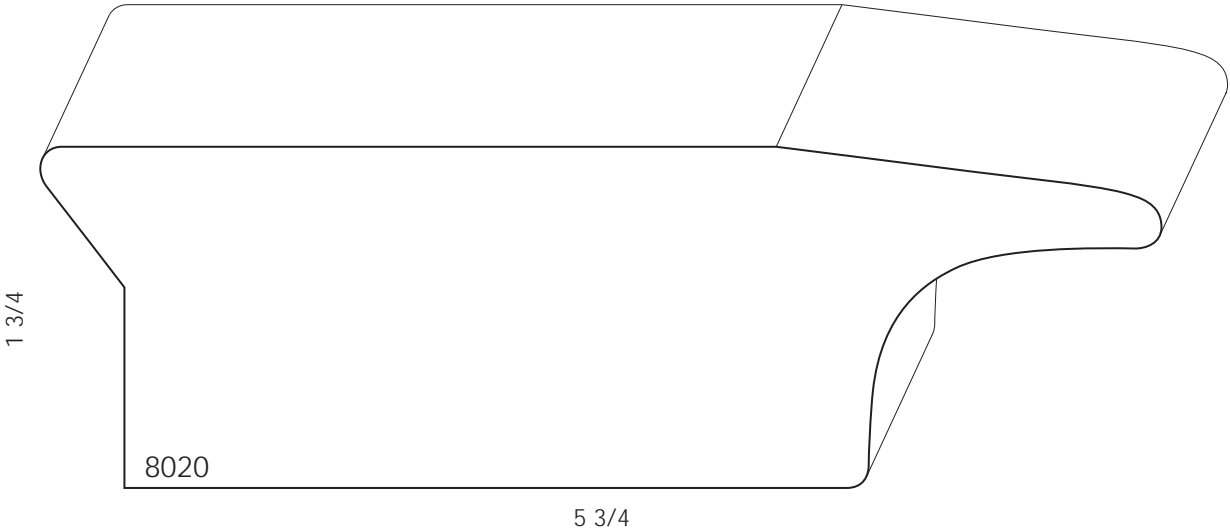
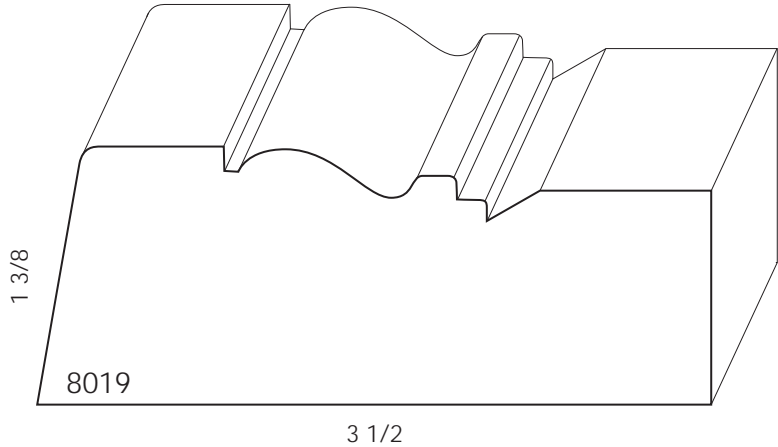

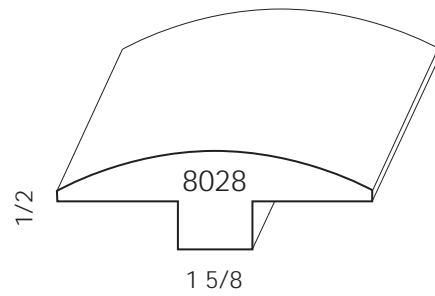
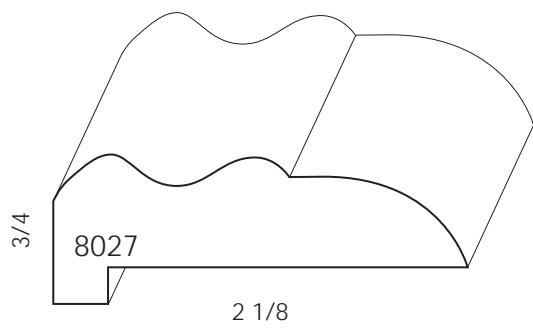
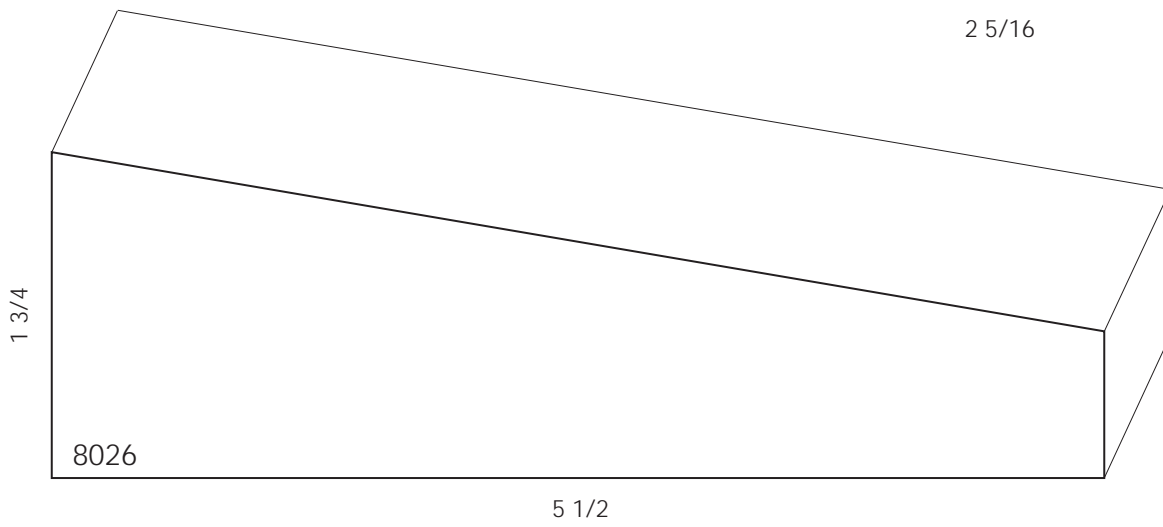
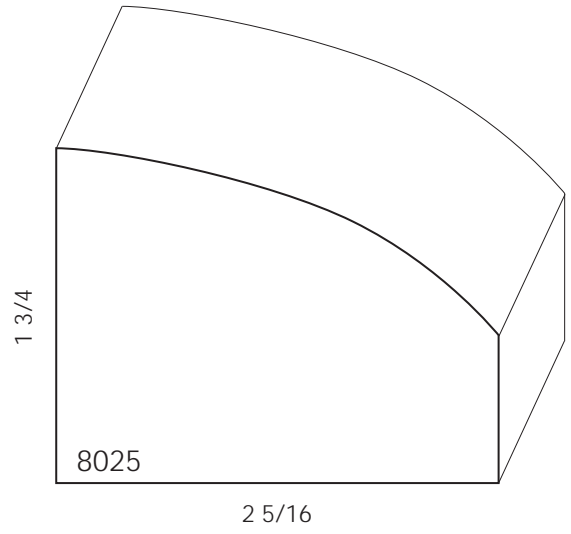
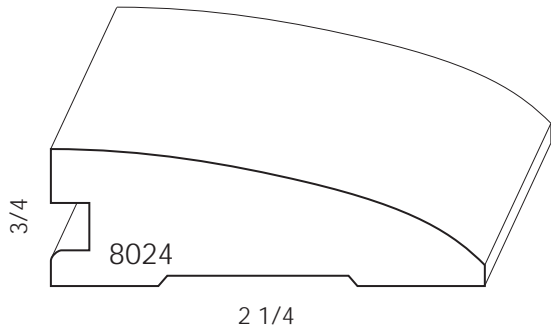
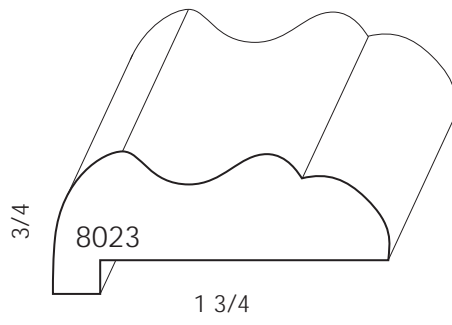

Miscellaneous

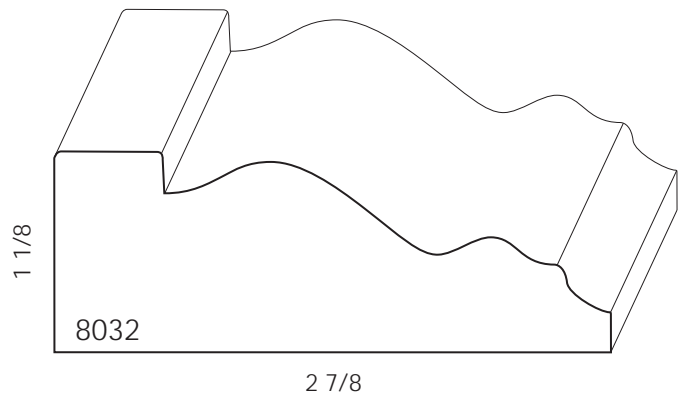
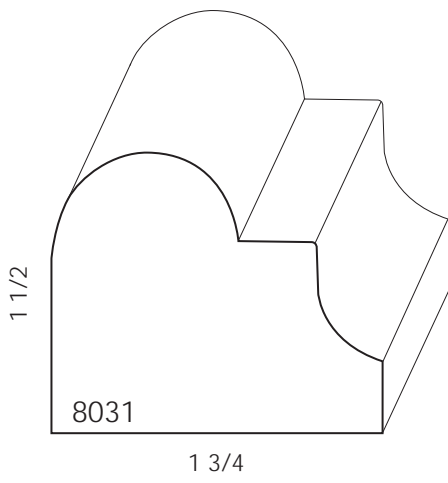
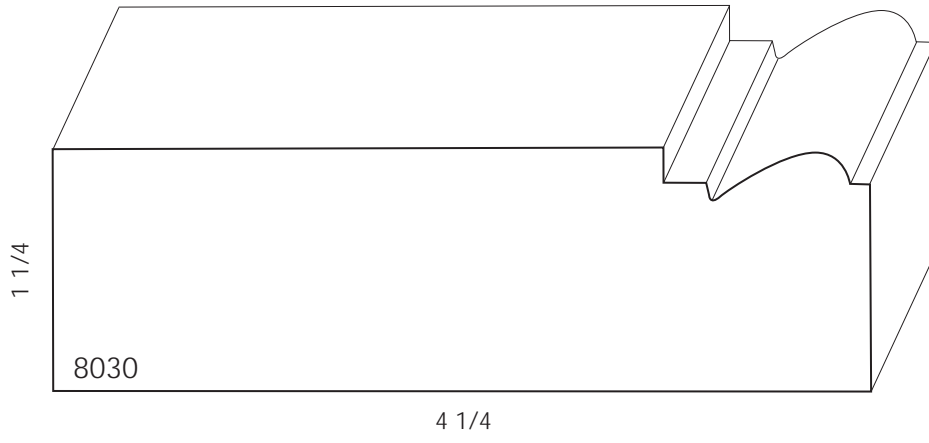
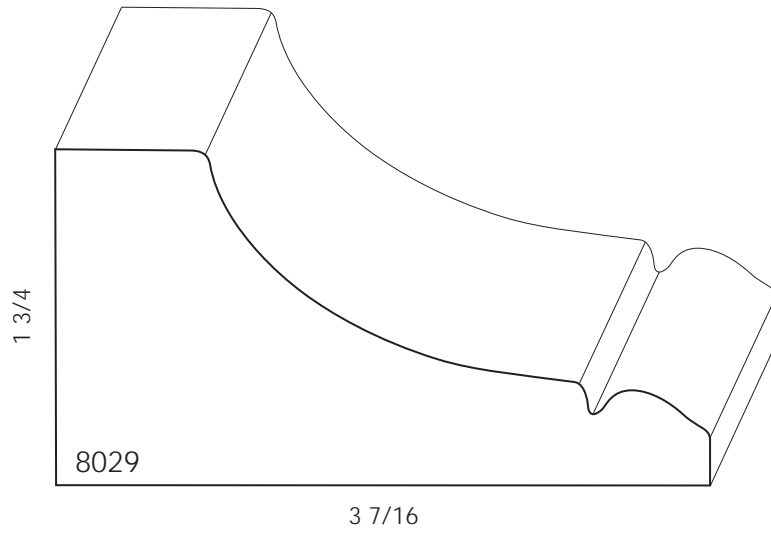

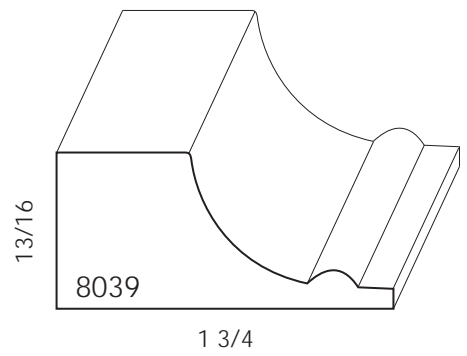
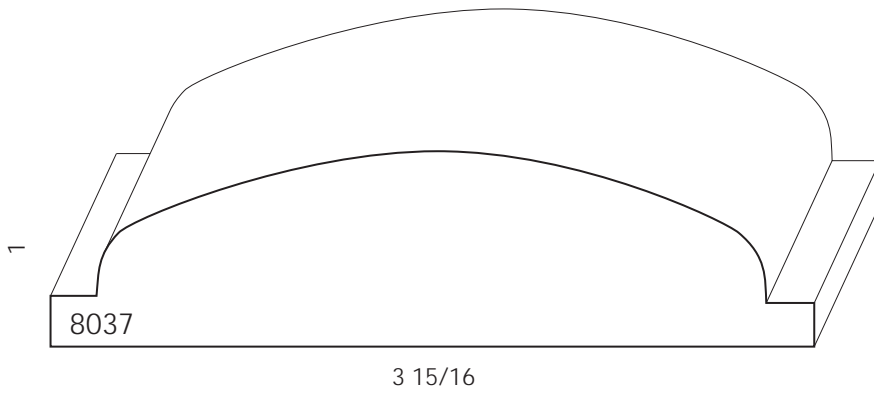
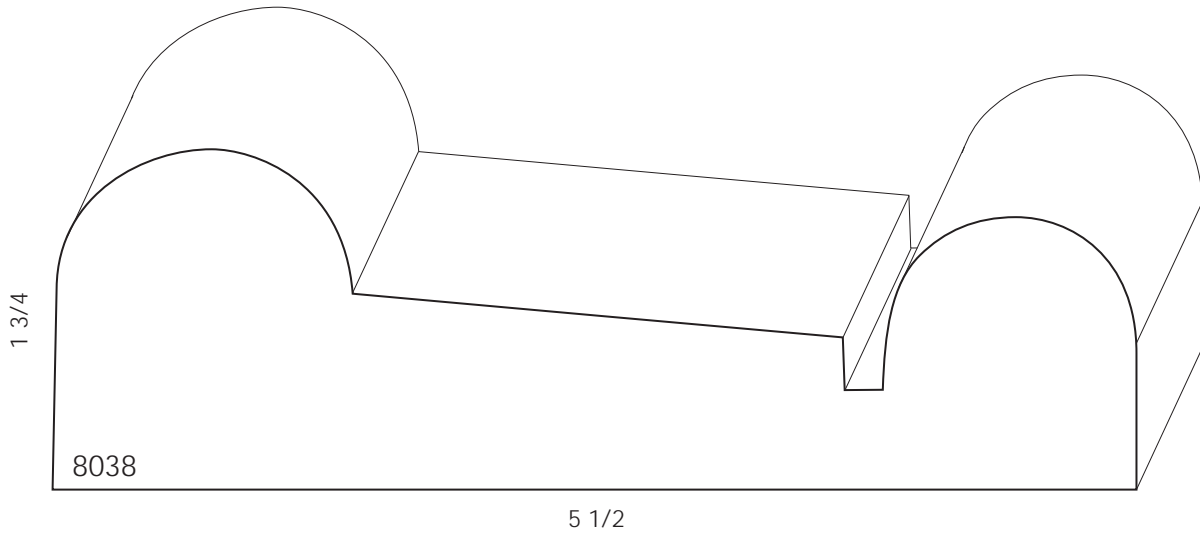
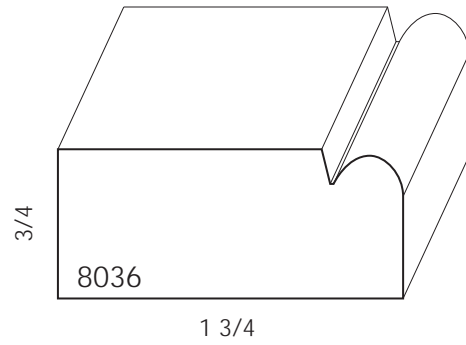
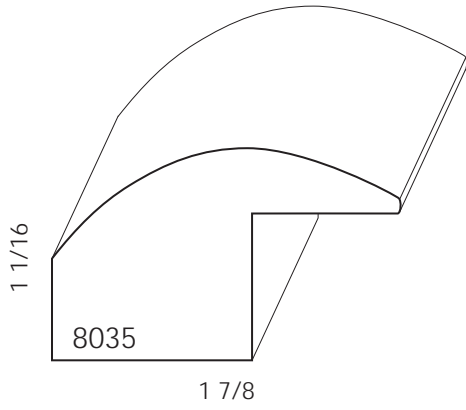
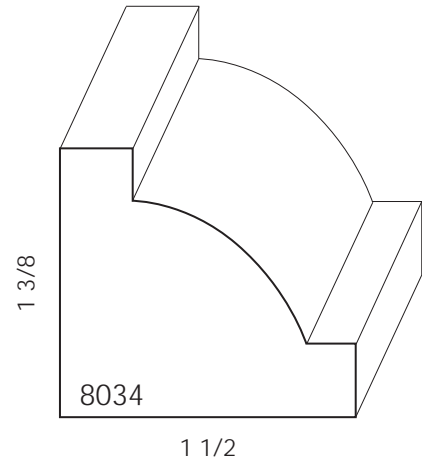
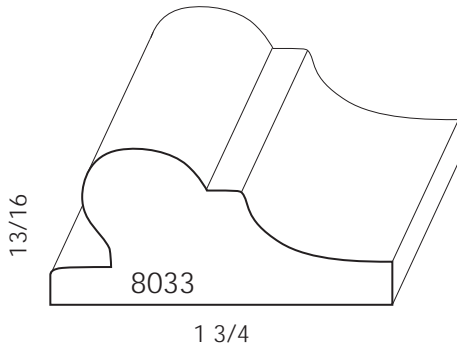

Miscellaneous

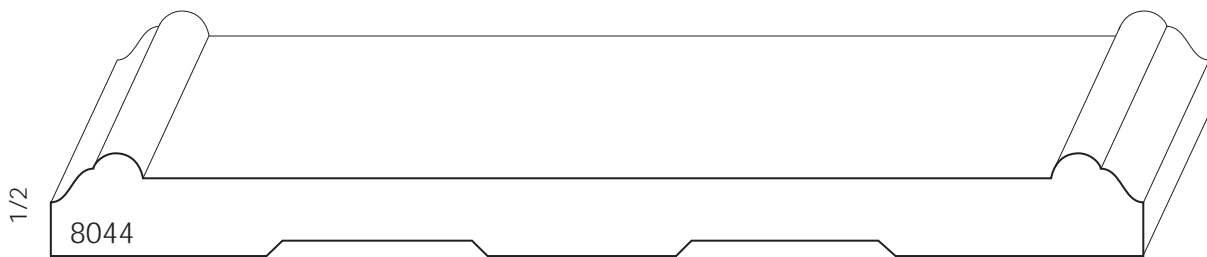
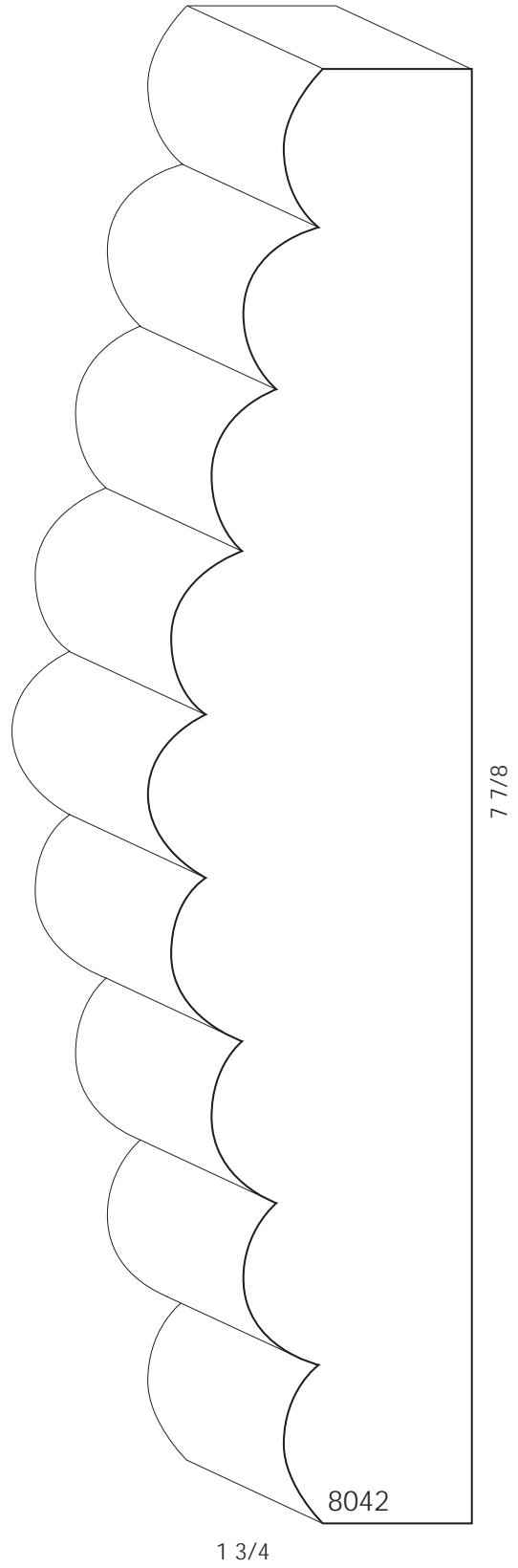
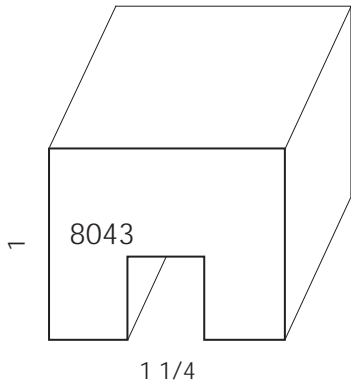
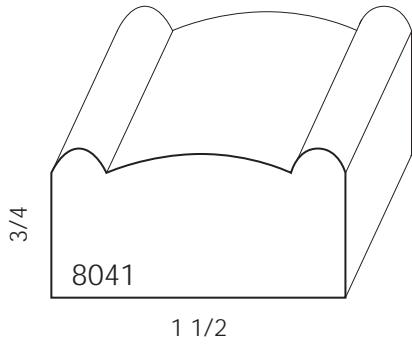
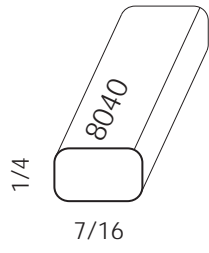

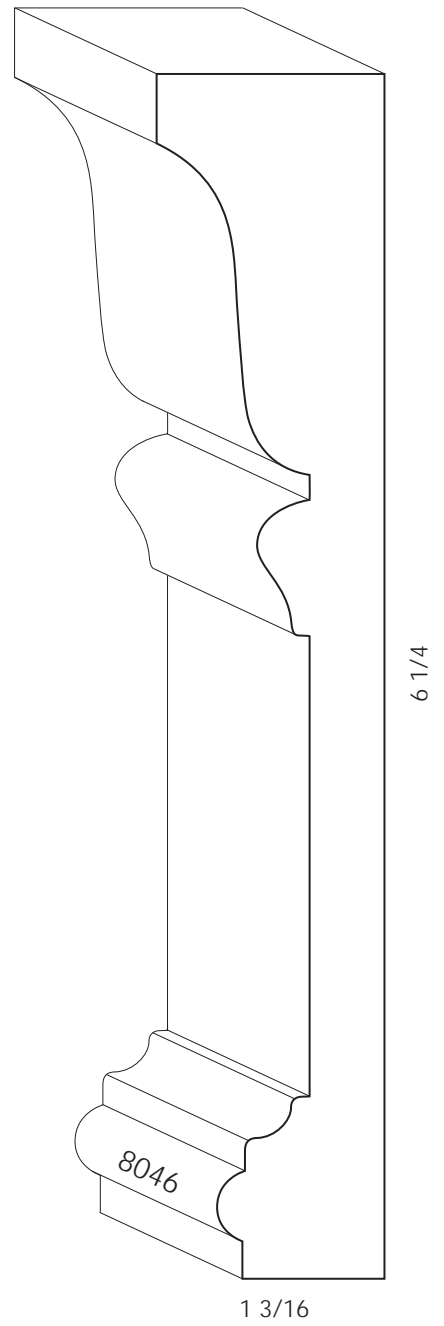
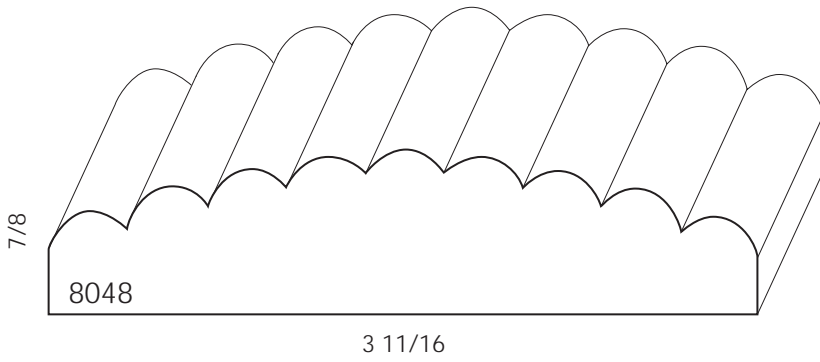
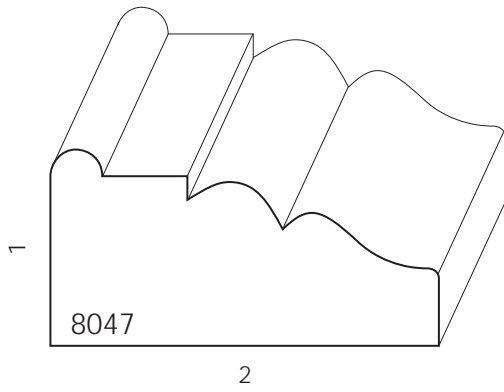
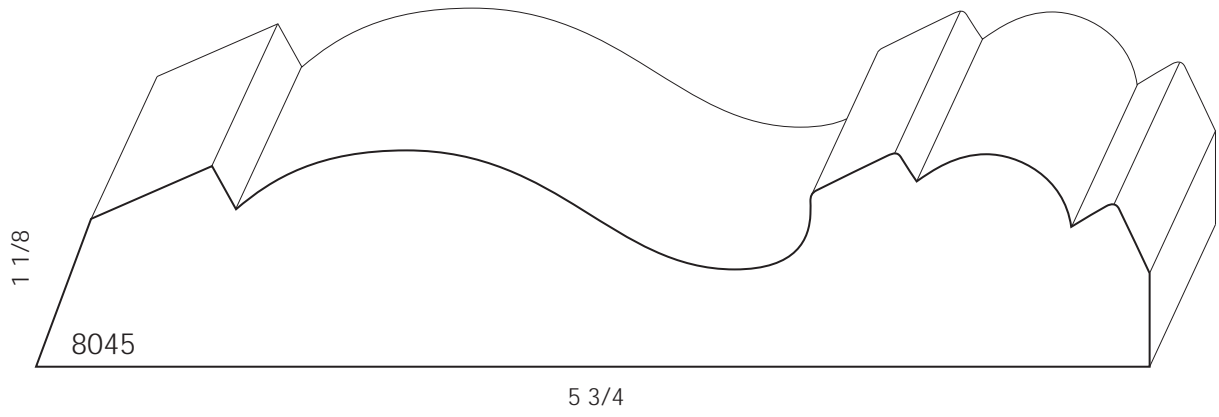

Miscellaneous

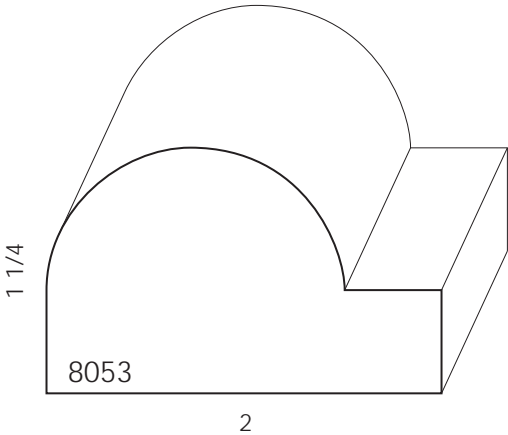
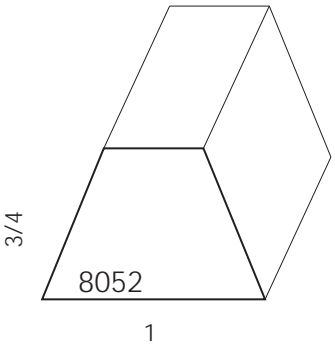
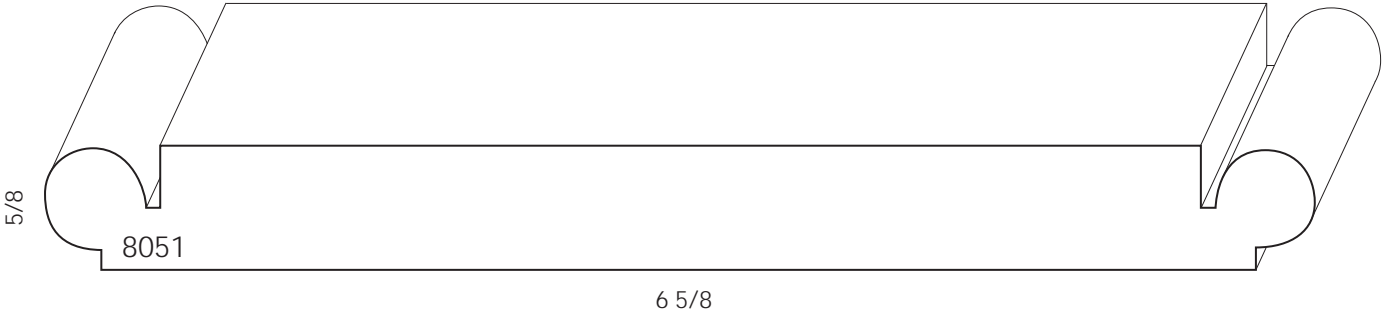
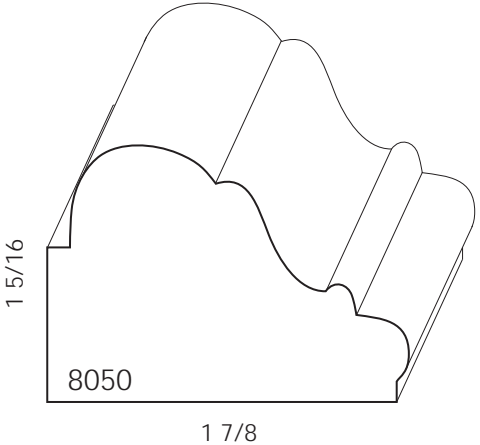
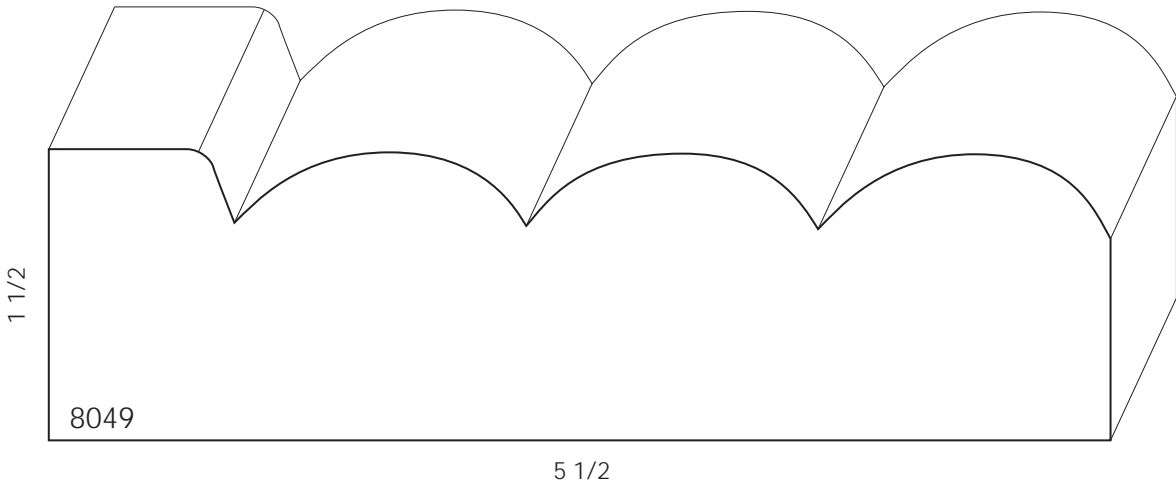

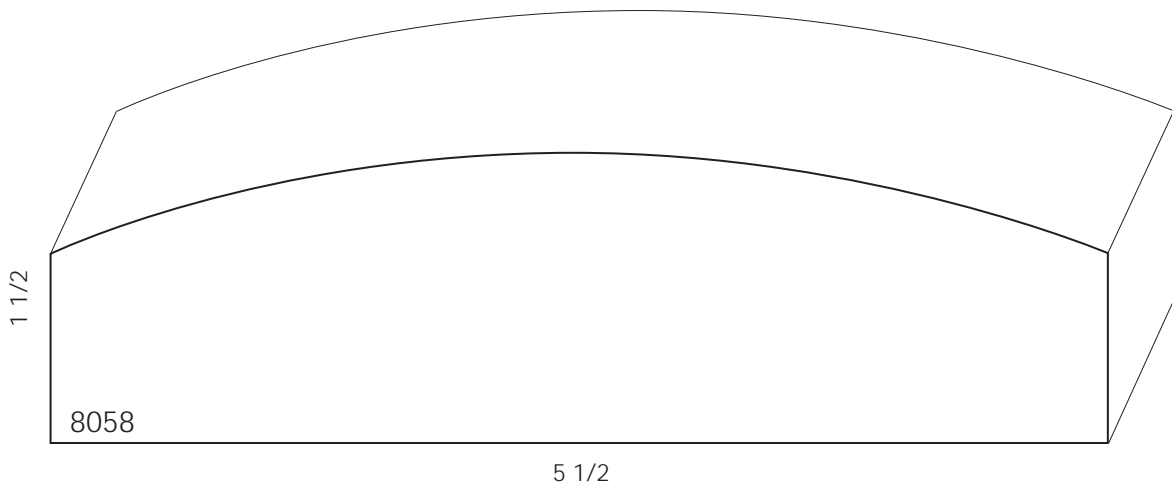
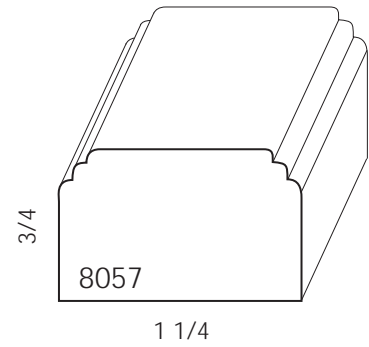
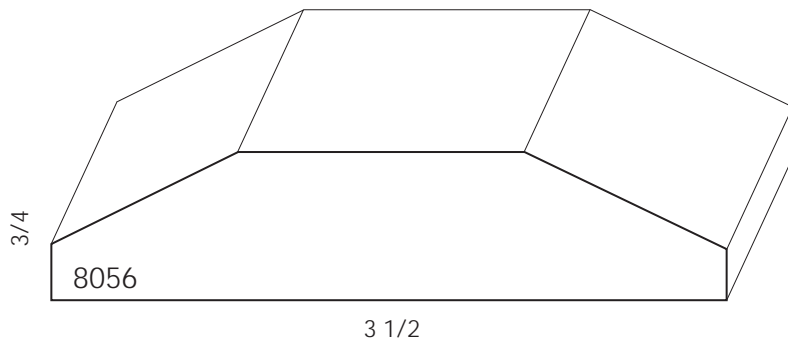
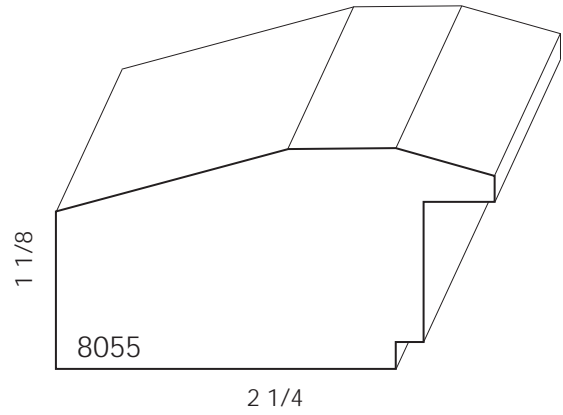

Miscellaneous

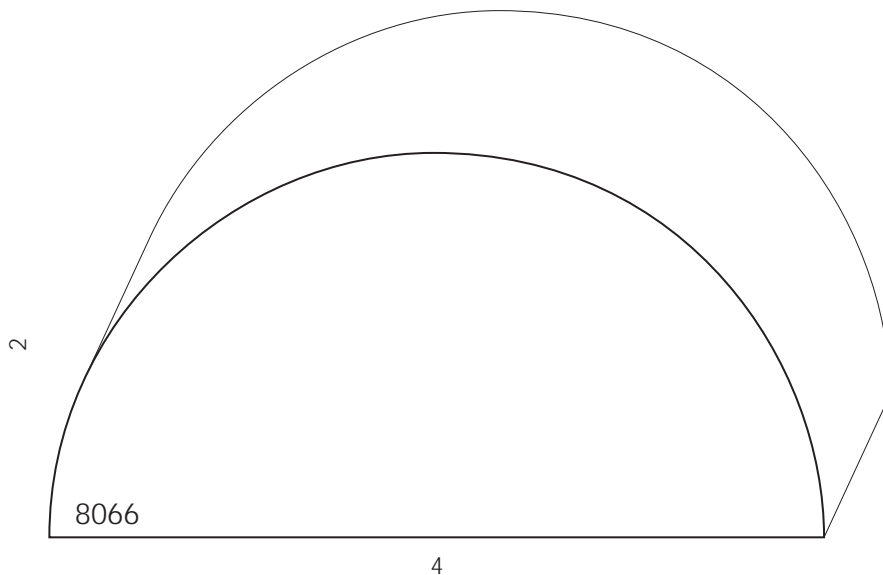
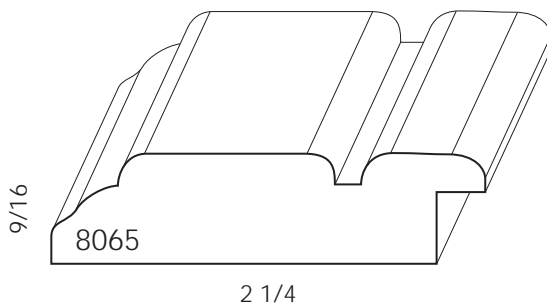
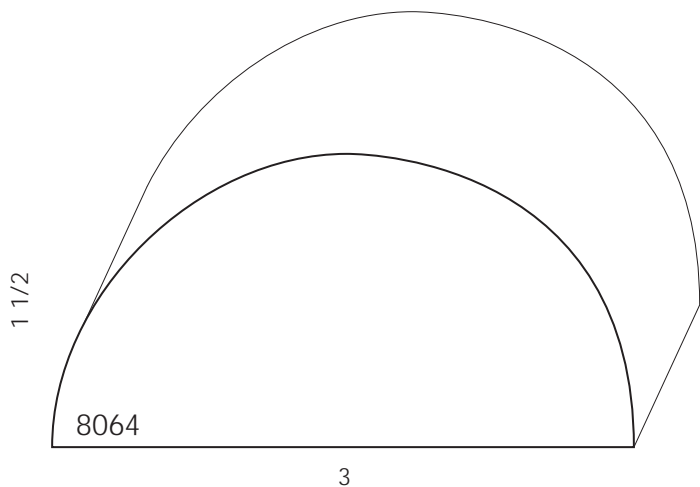
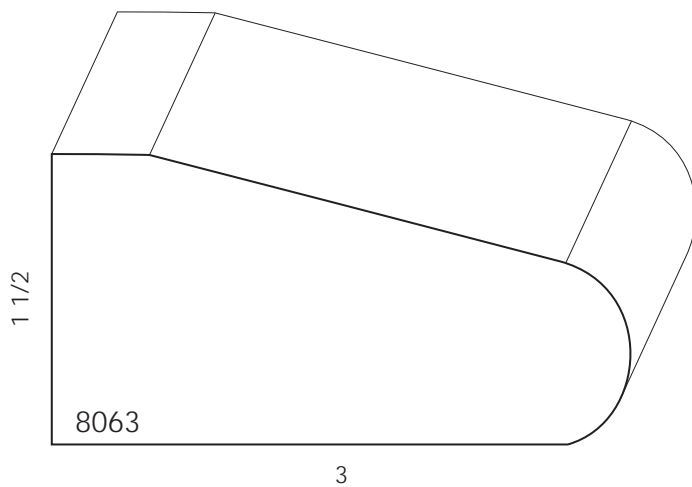
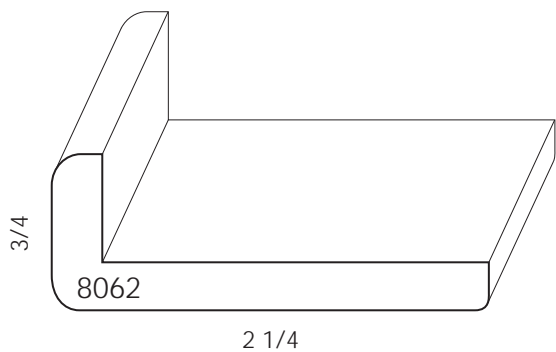
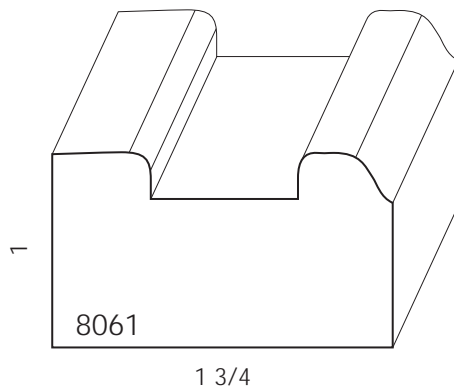
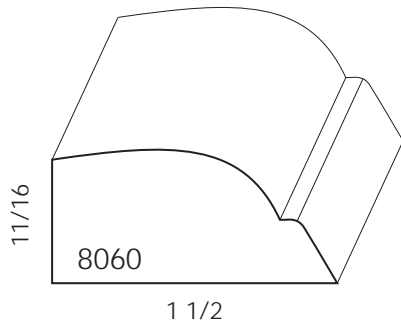
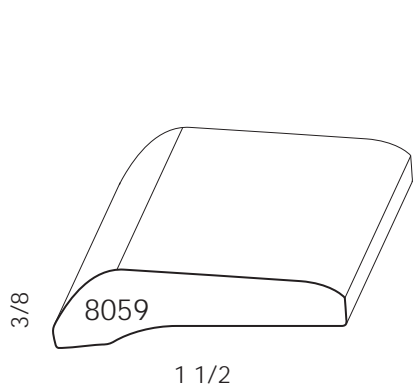

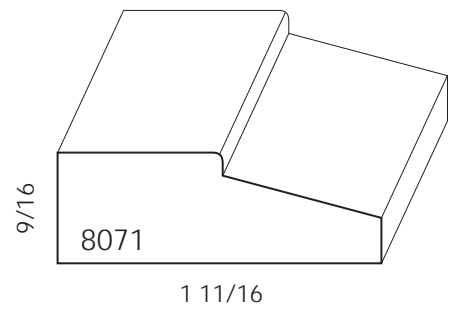
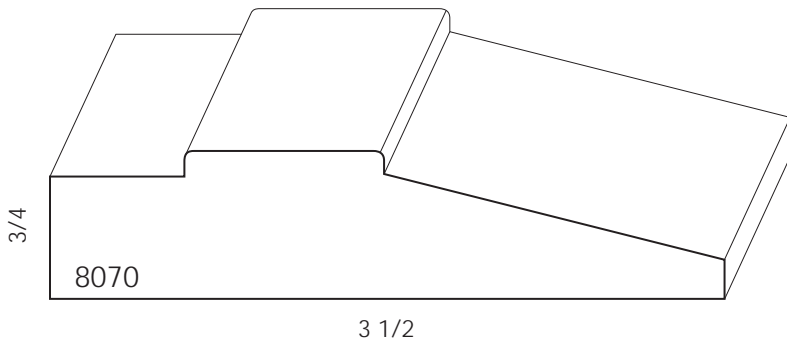
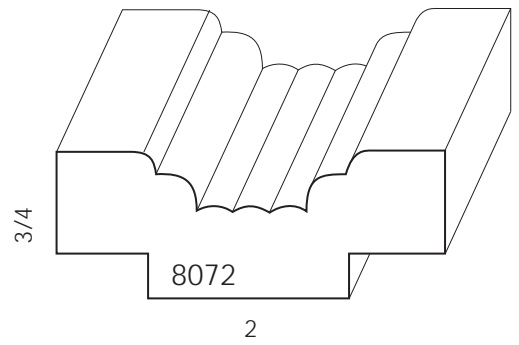
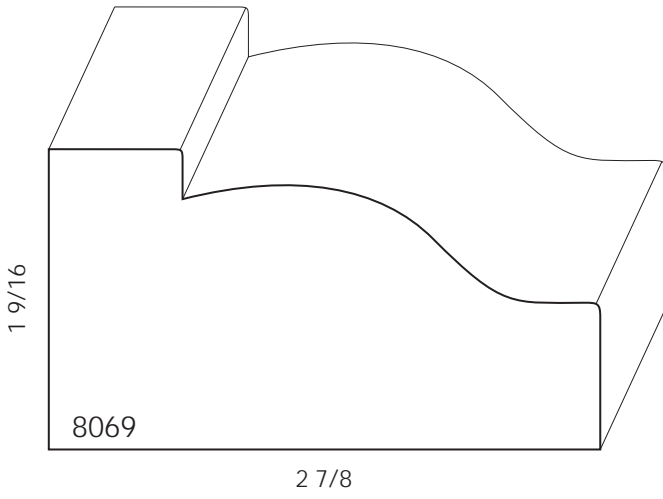
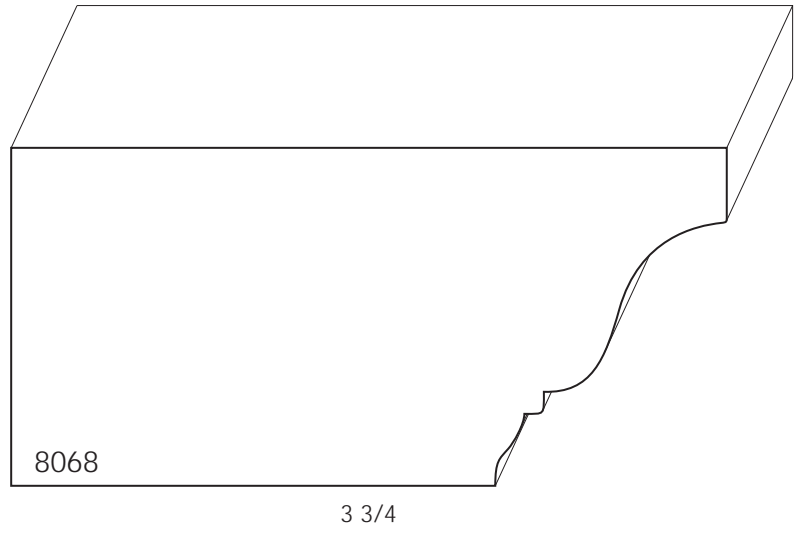
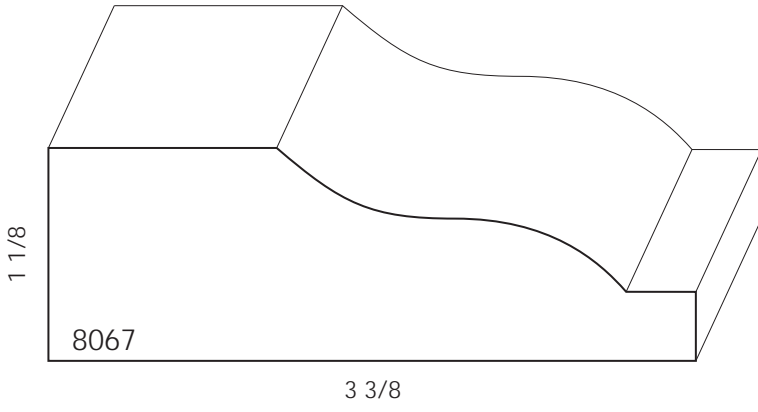

Miscellaneous

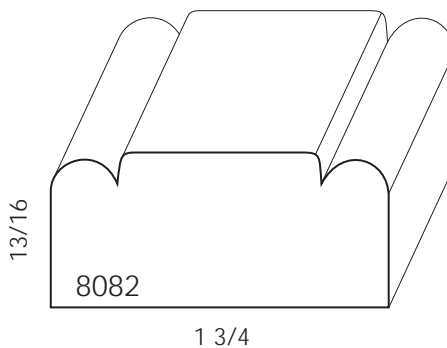
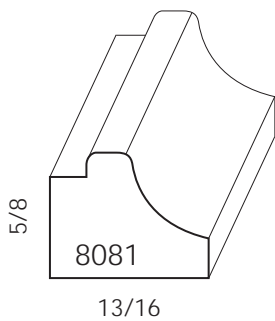
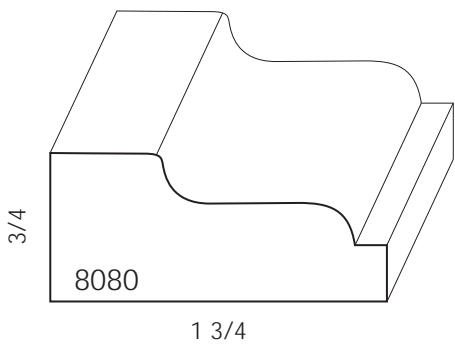
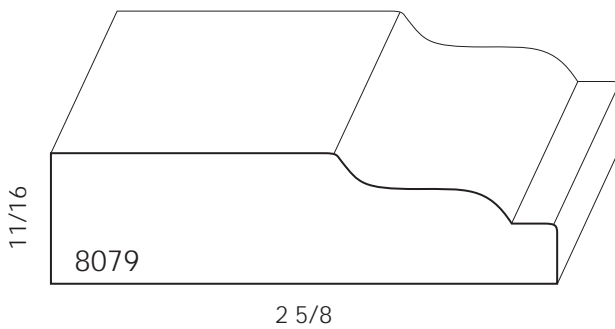
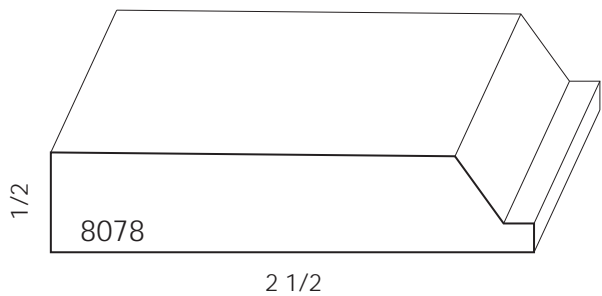
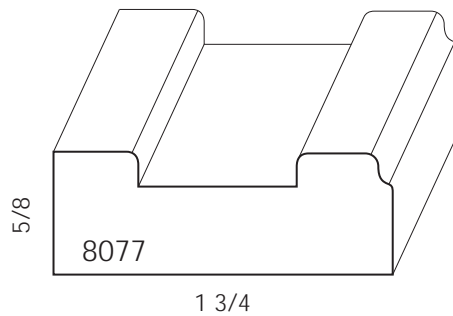
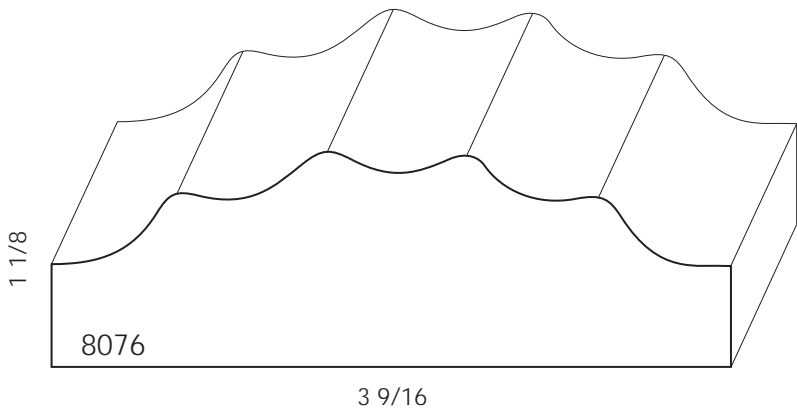
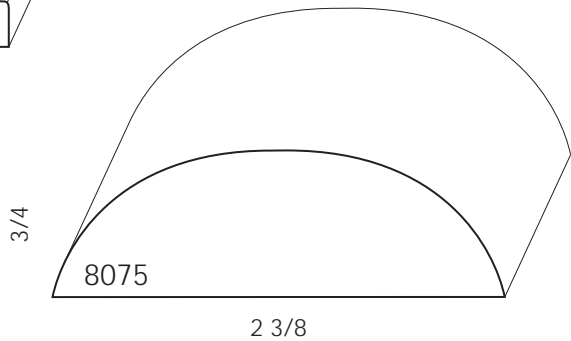
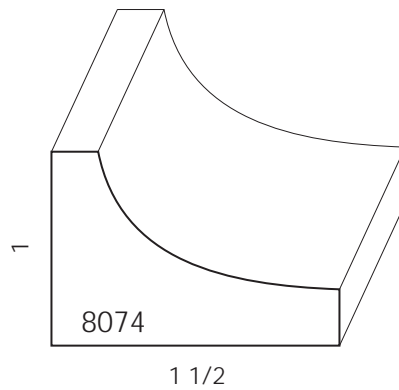
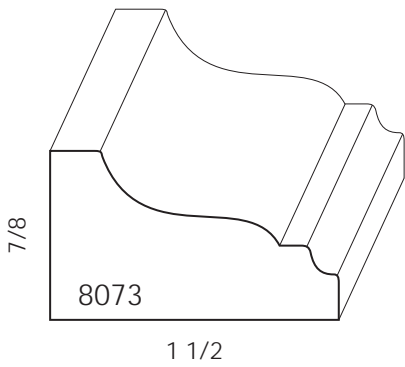

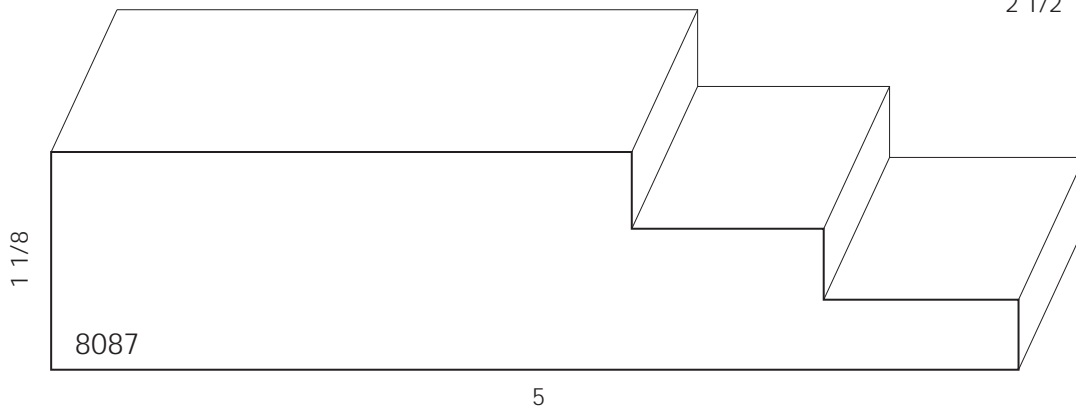
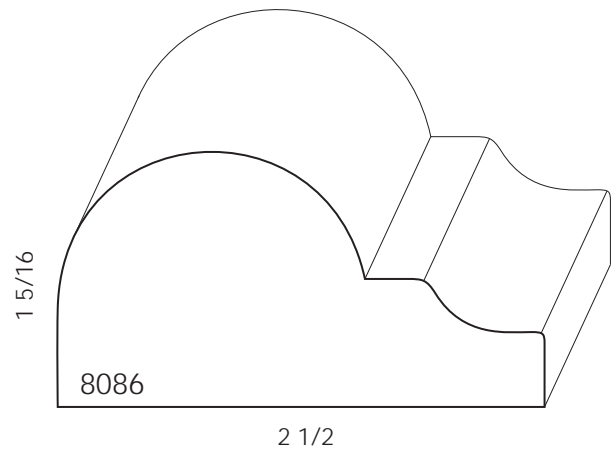
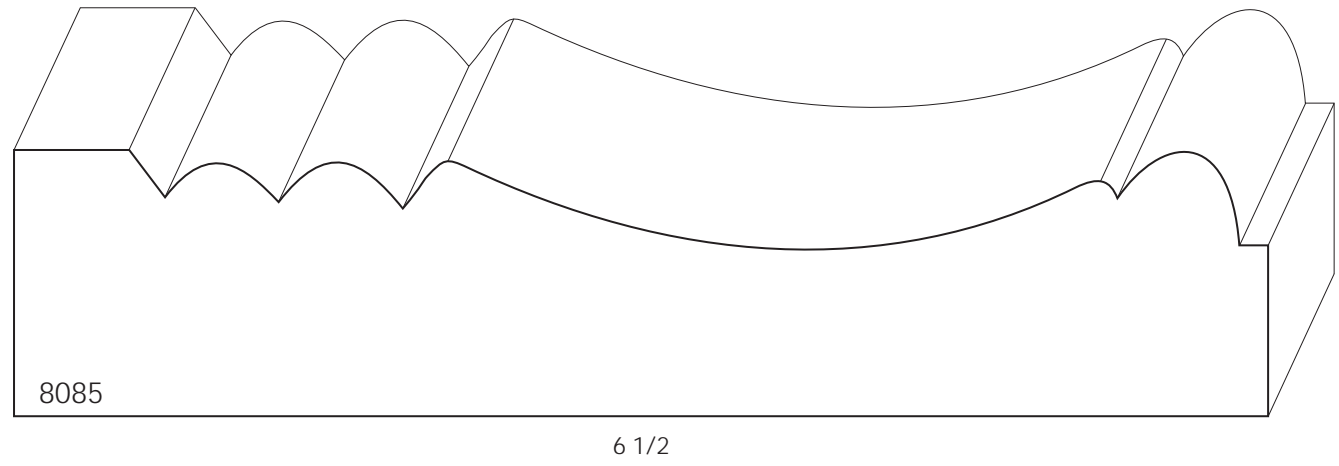
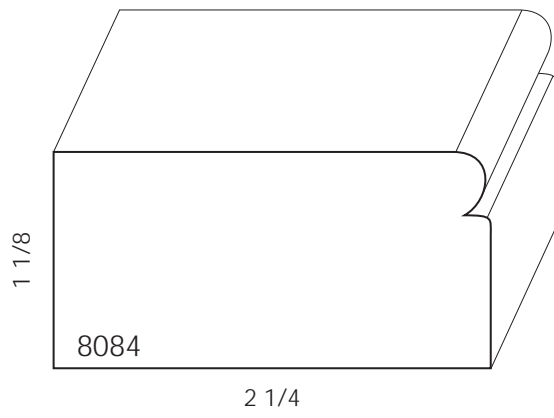
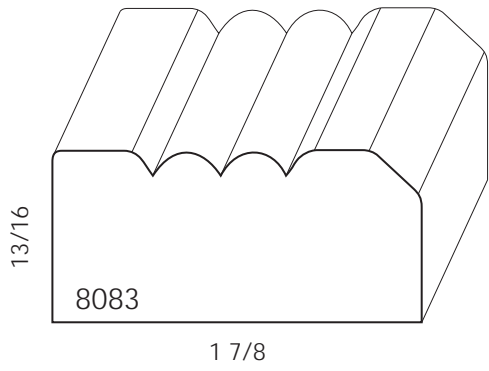

Miscellaneous

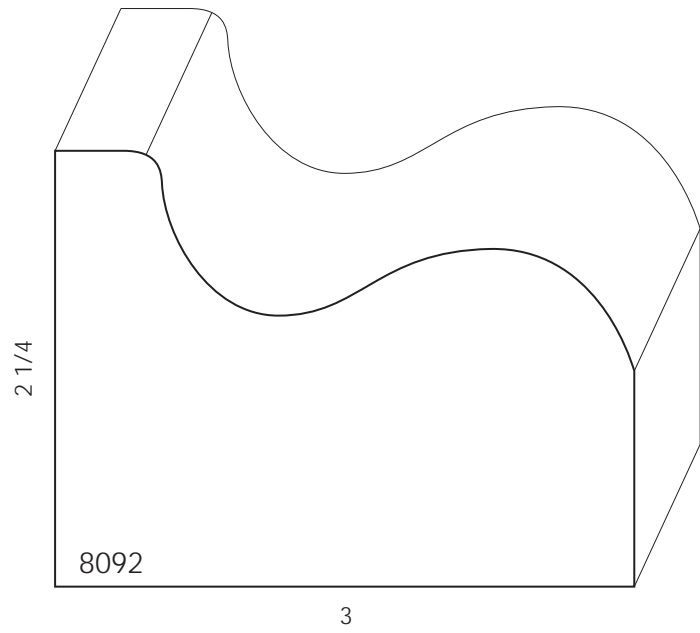
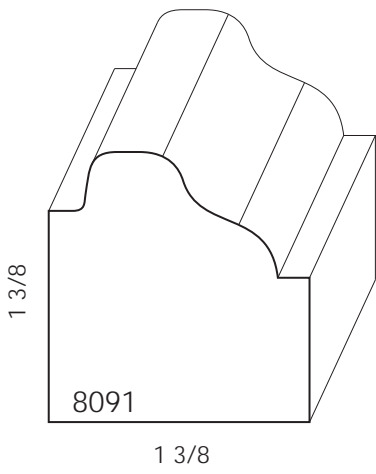
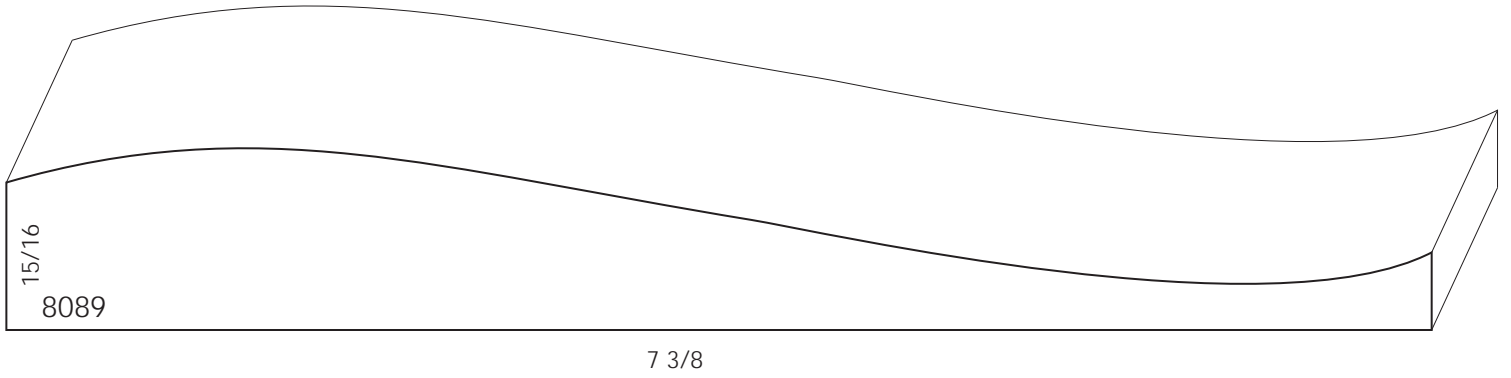
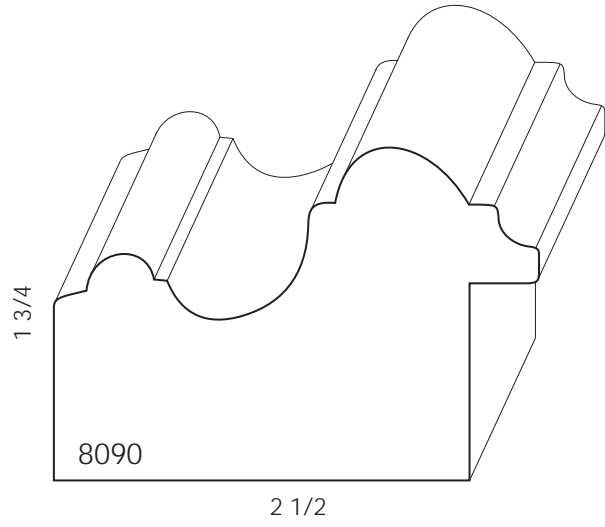
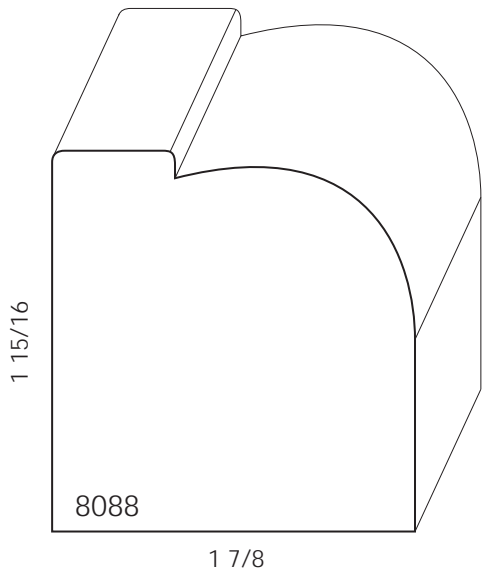

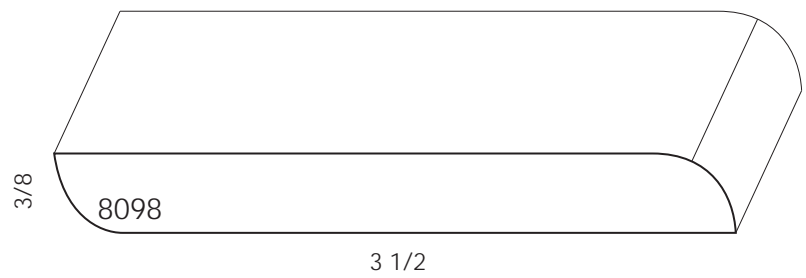
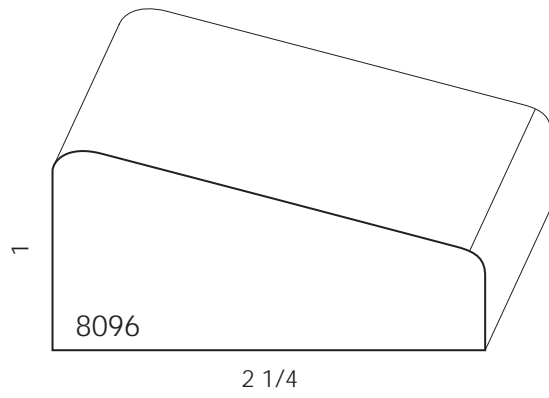
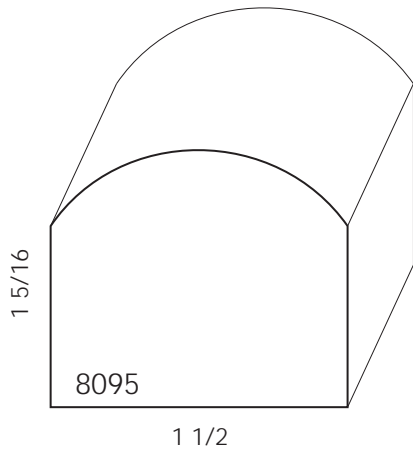
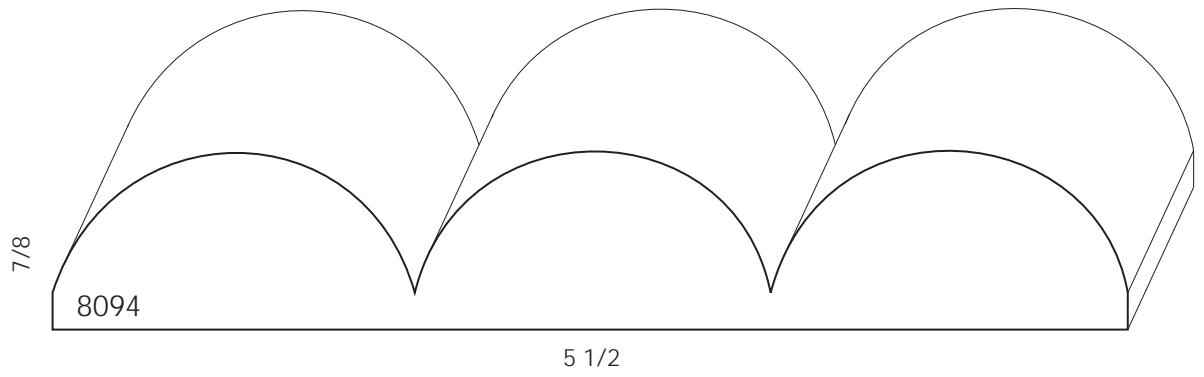
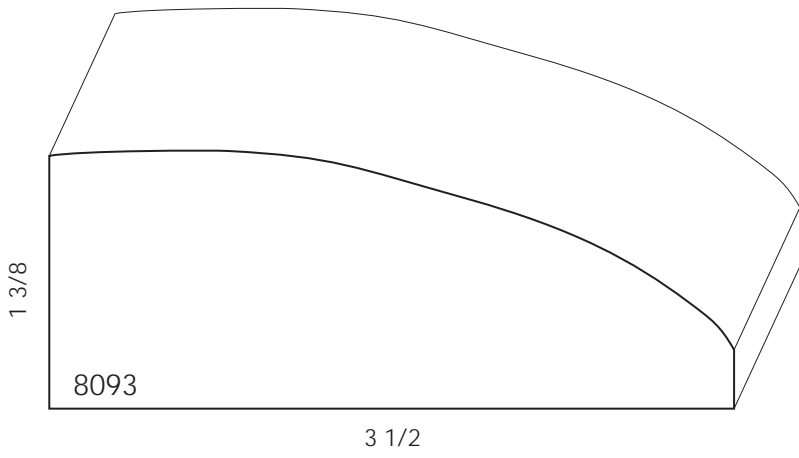

Miscellaneous

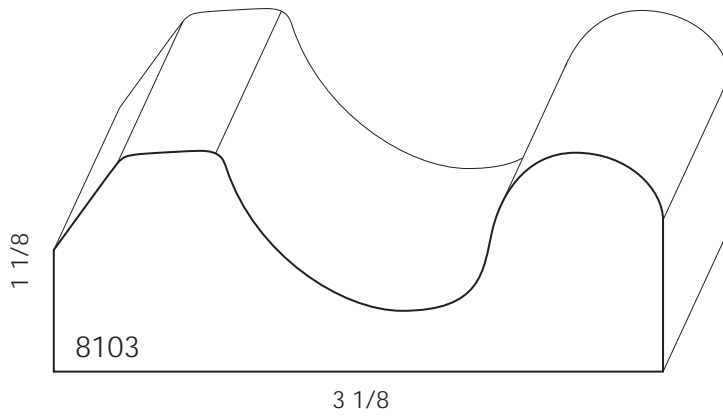
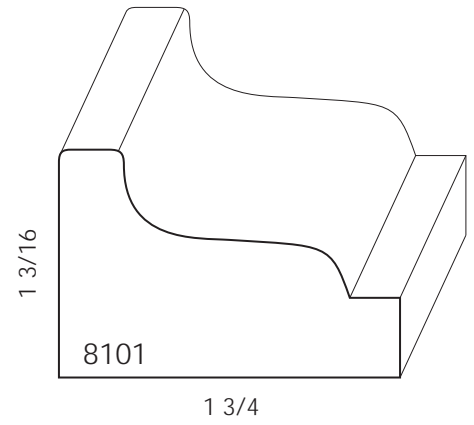
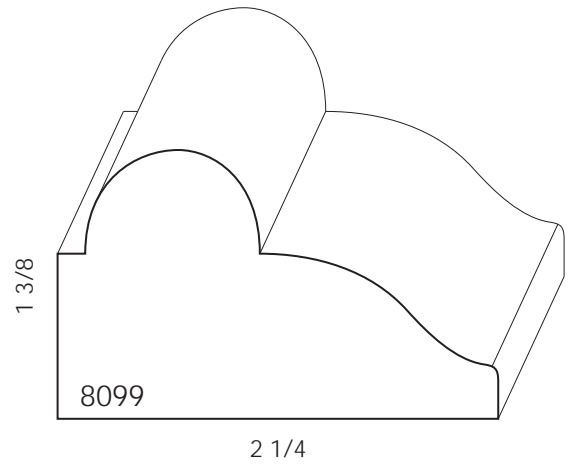
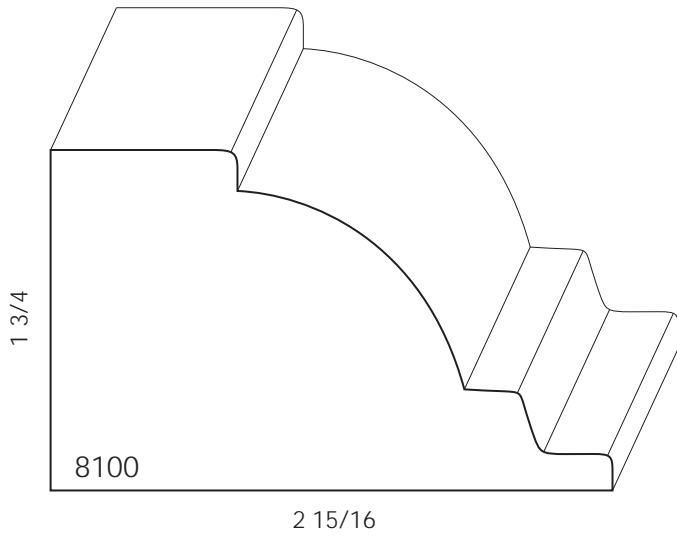

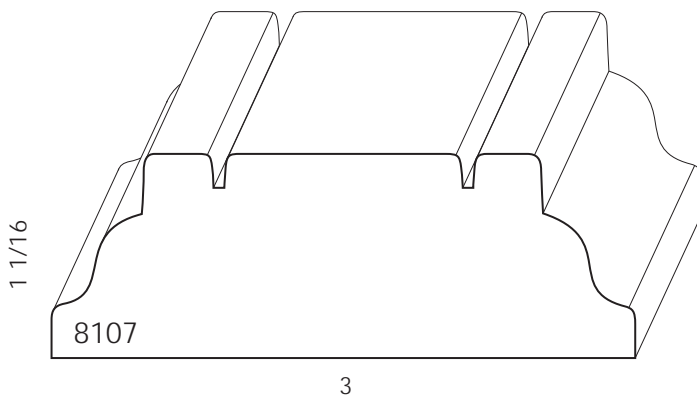
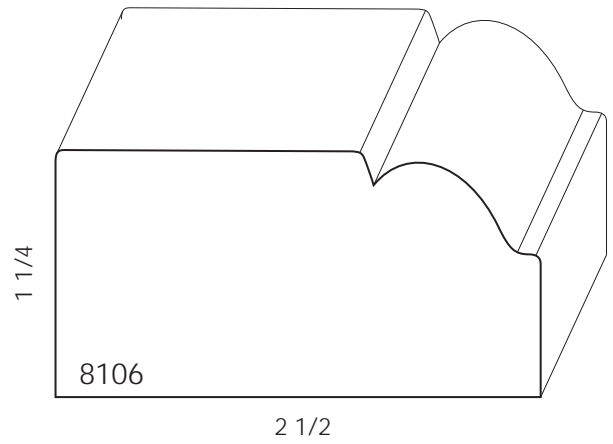
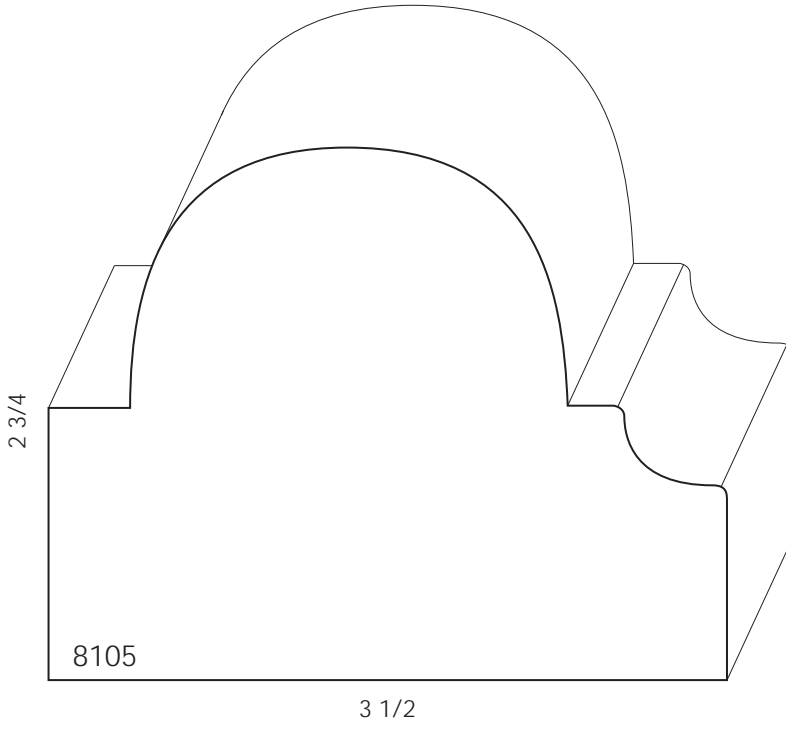
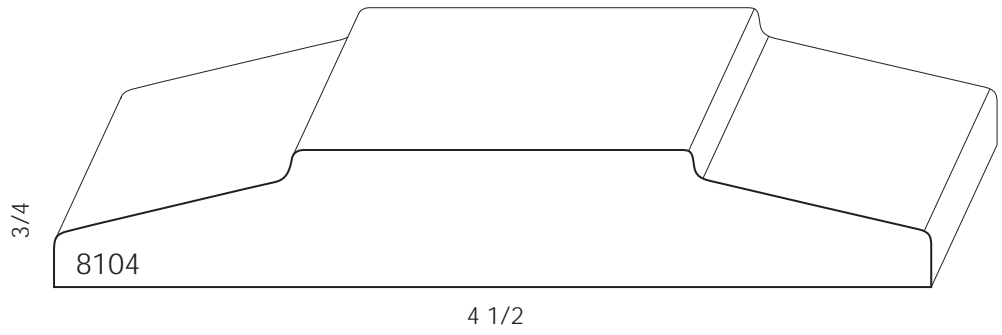

Plinth Block

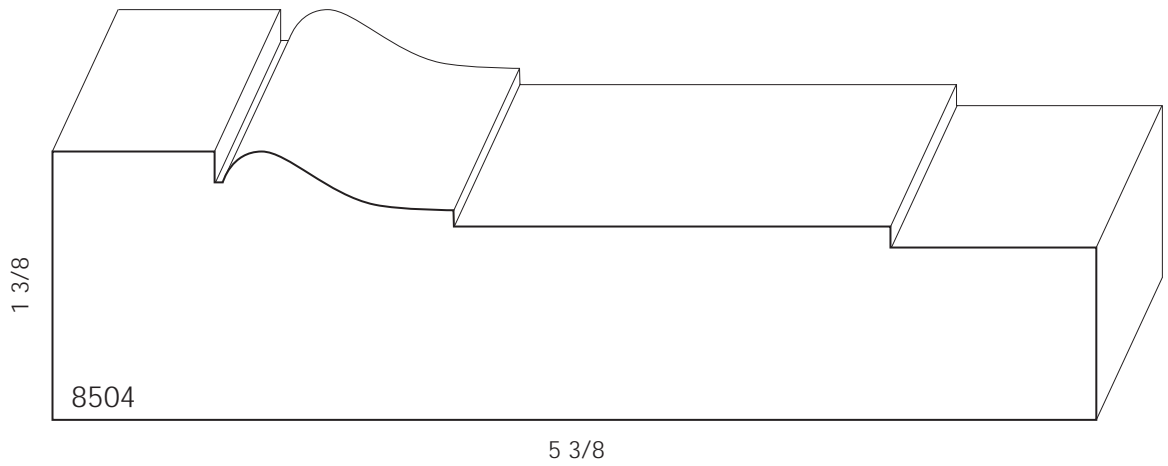
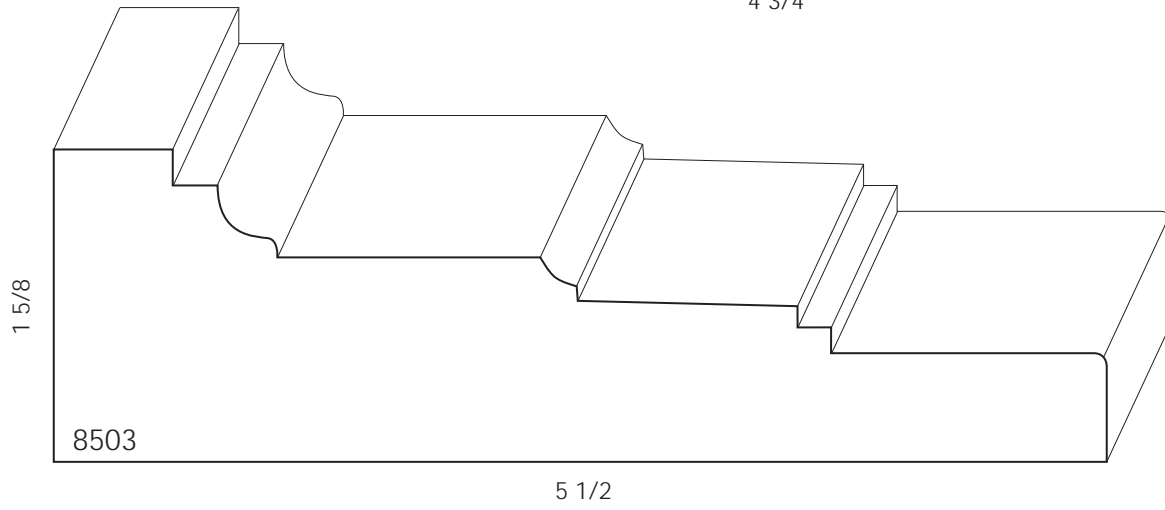
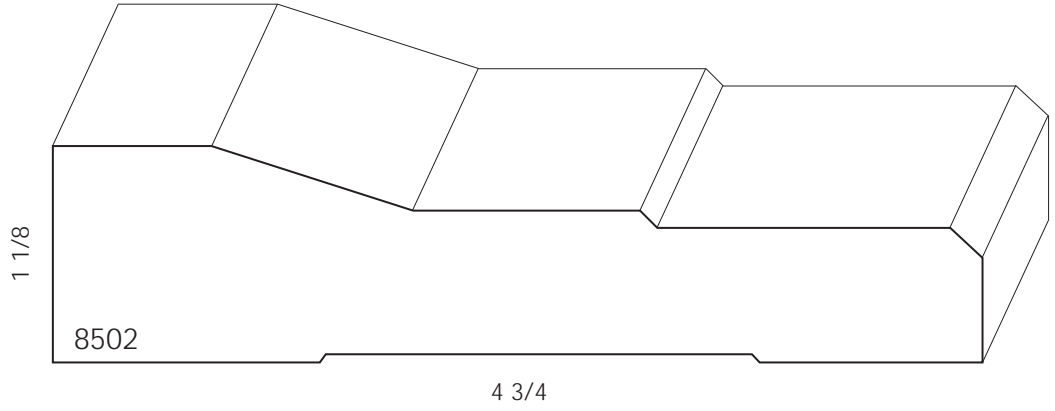
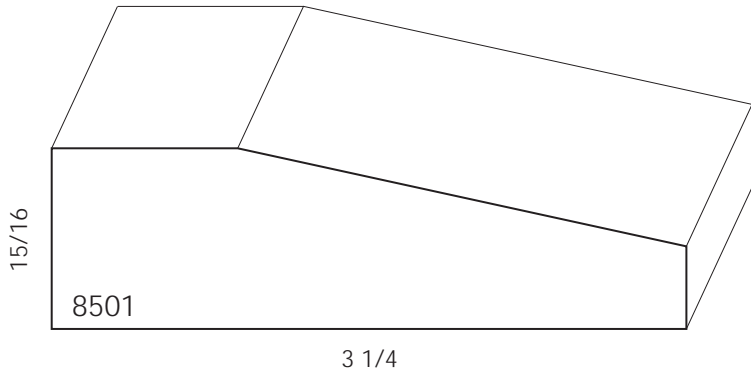

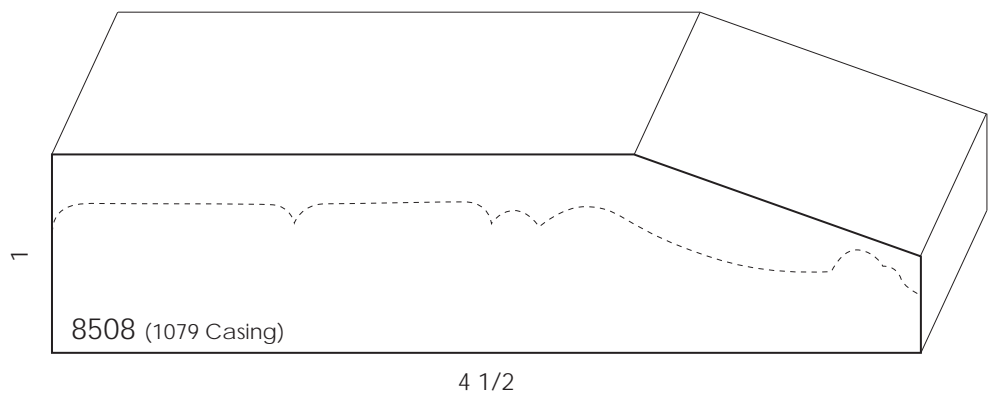
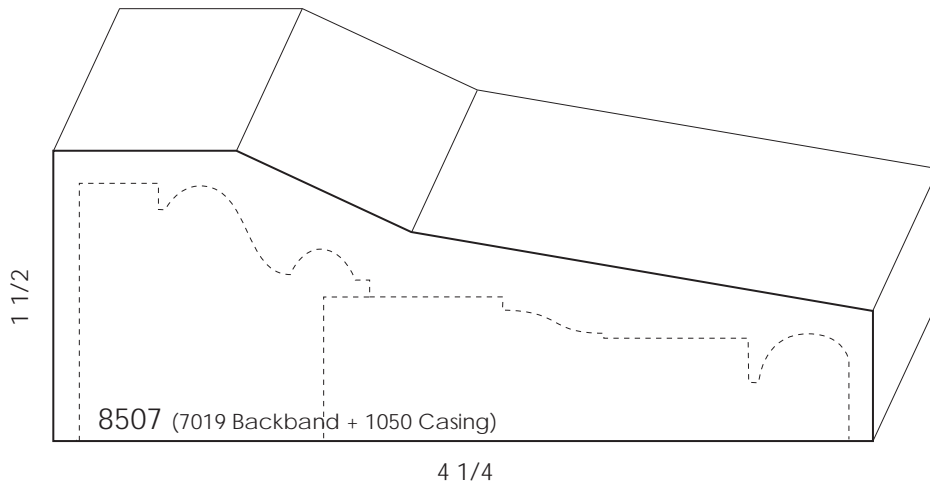
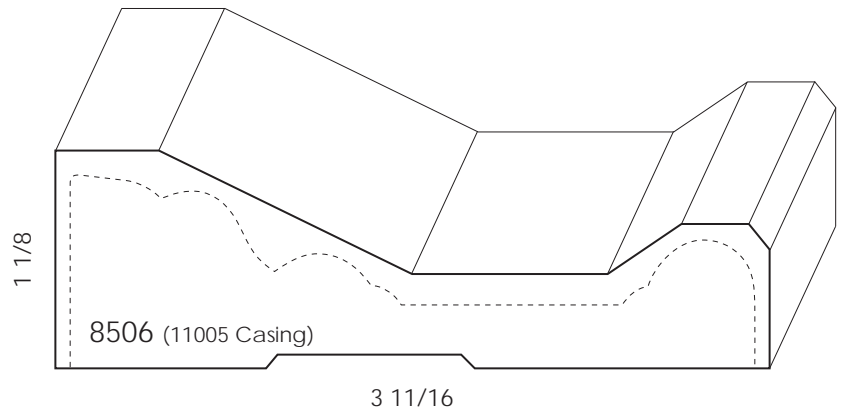
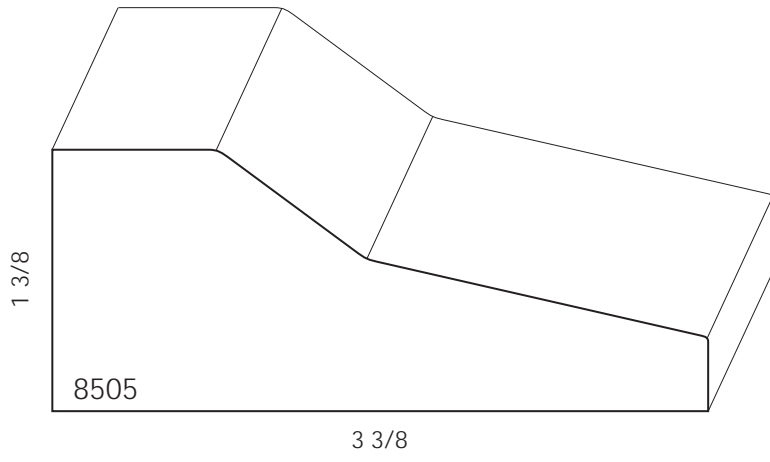

Plinth Block

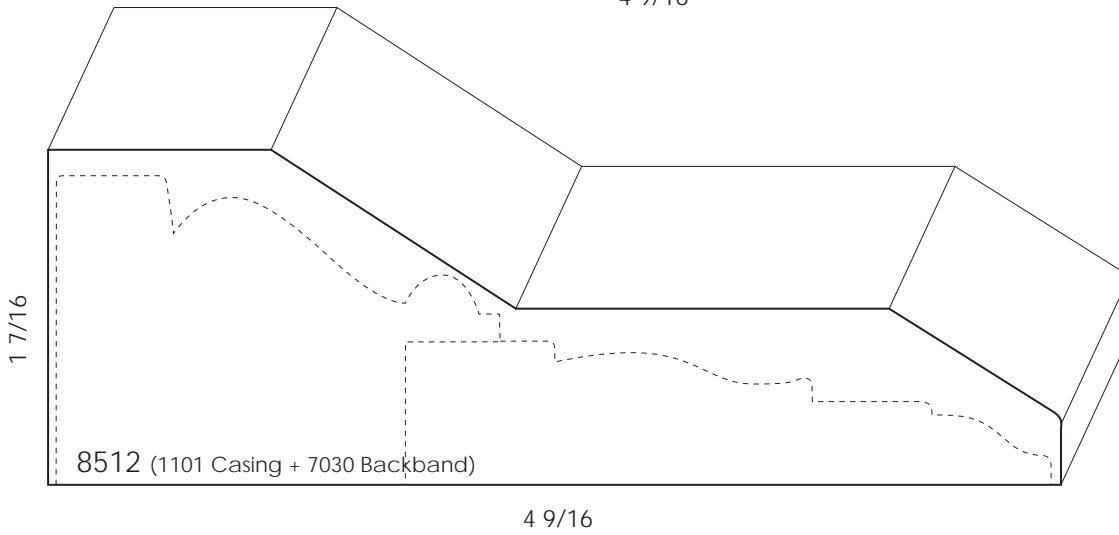
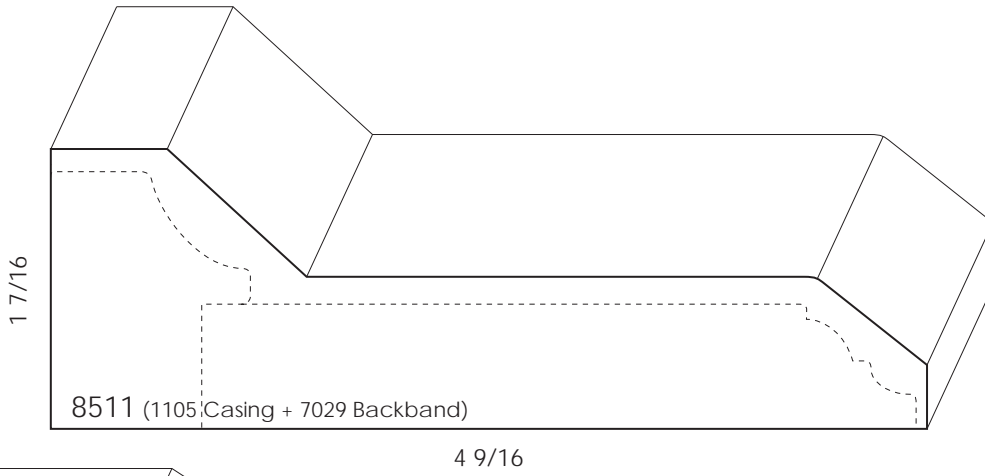
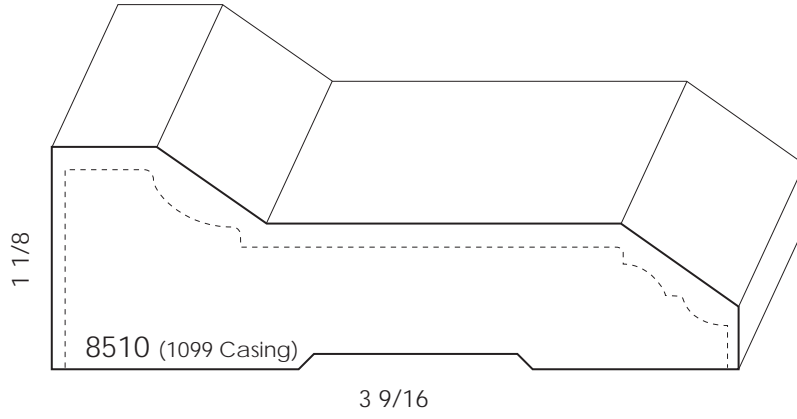
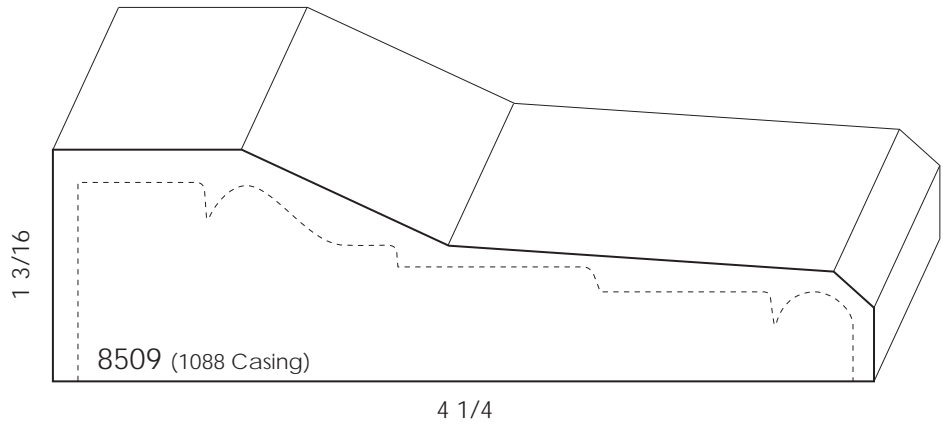

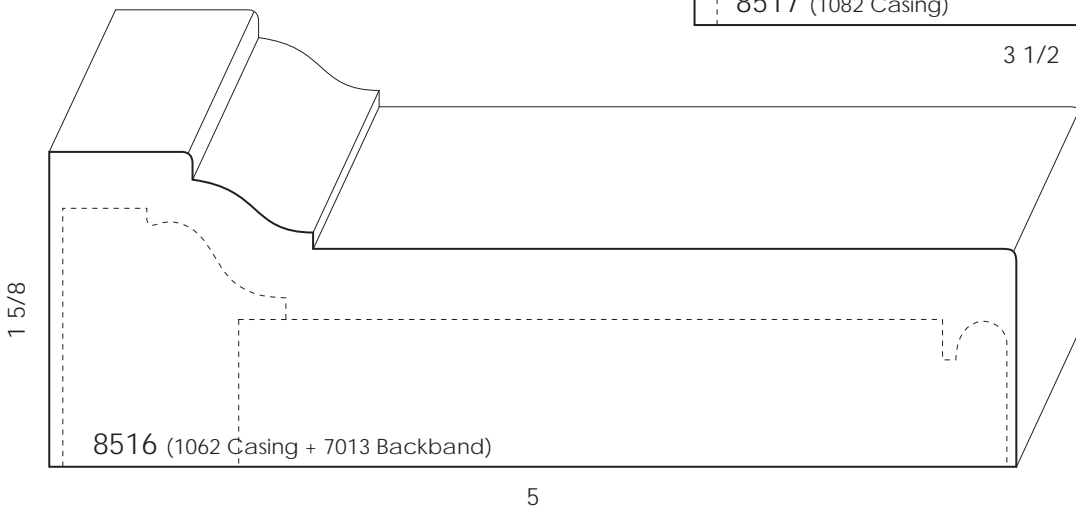
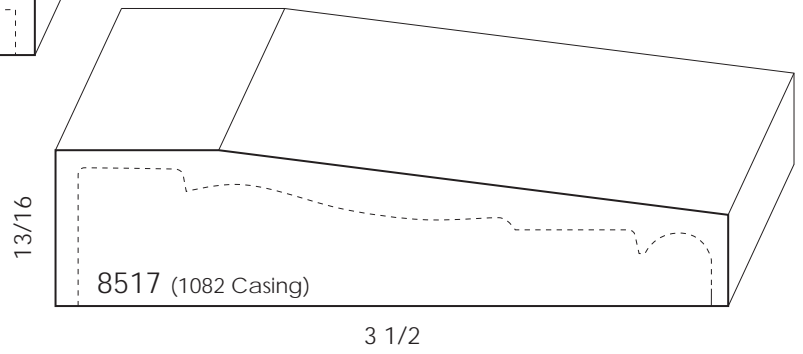
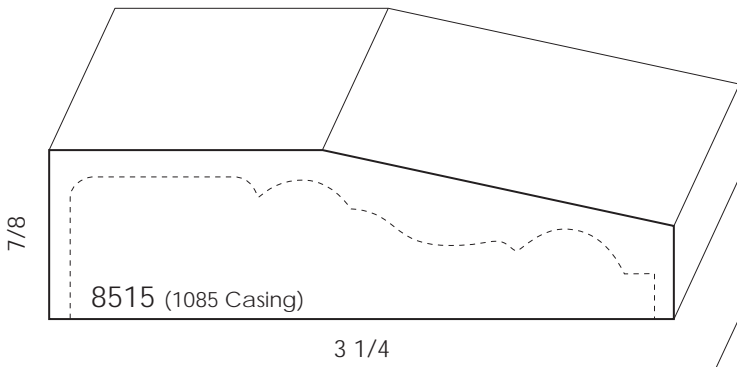
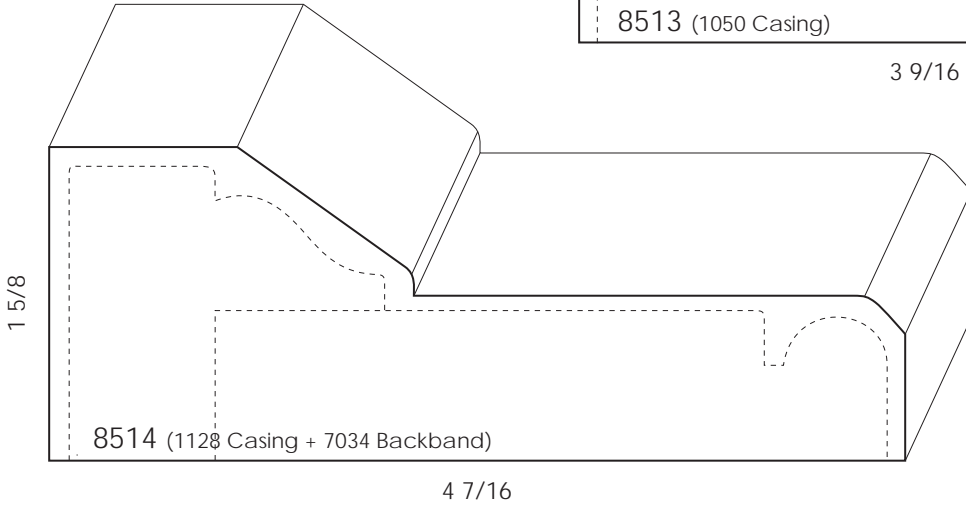
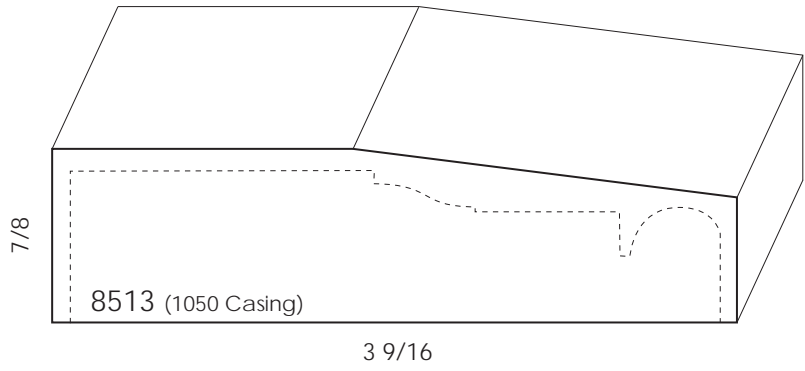

Plinth Block

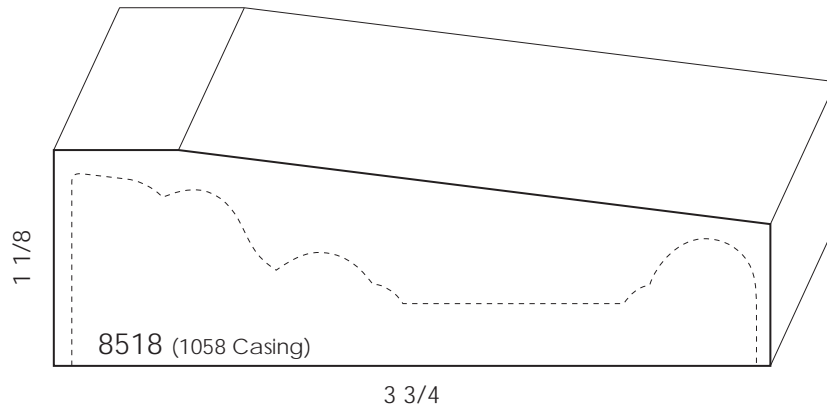

Bar Rail

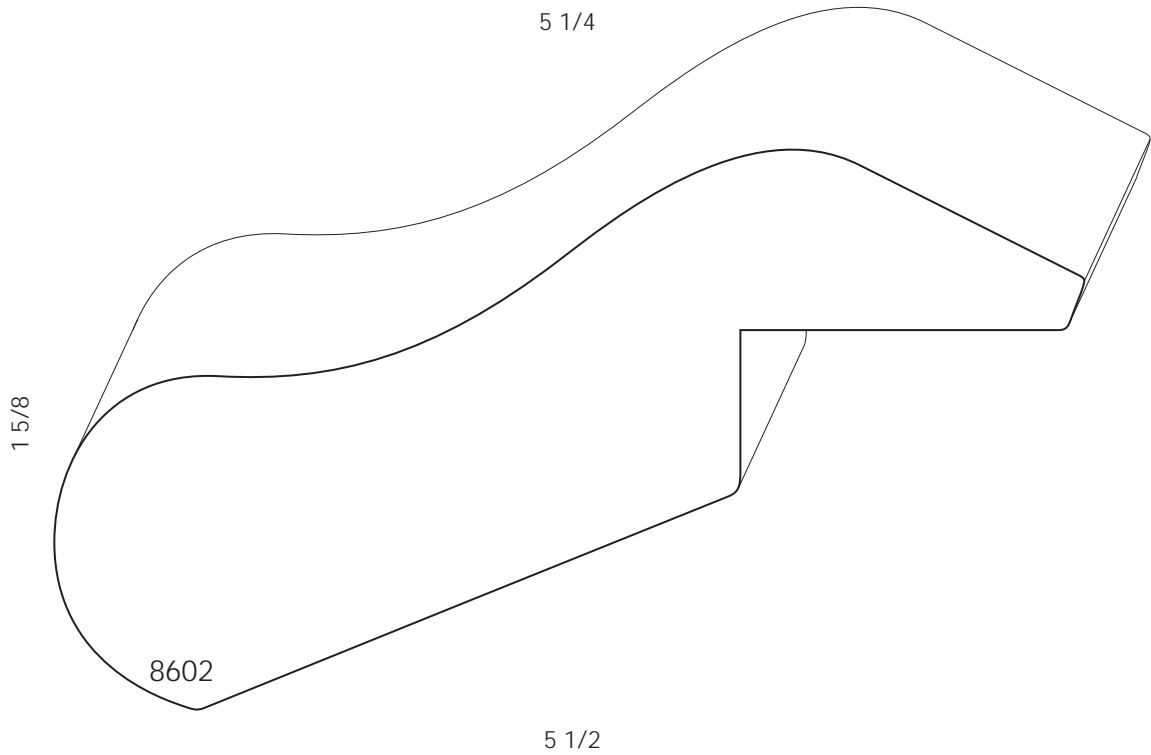
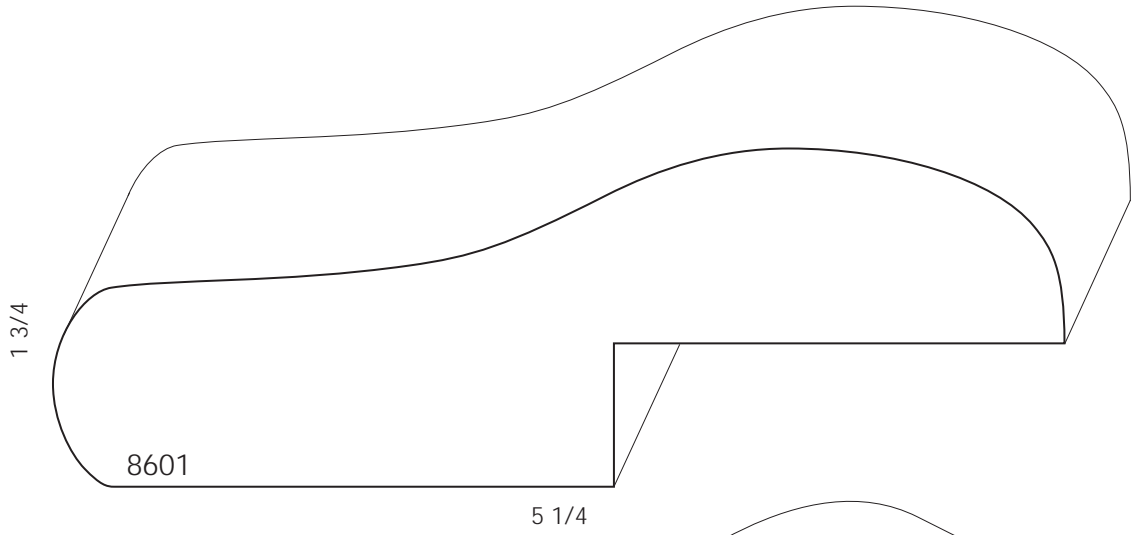

Tongue and Groove widths measure the exposed face only.

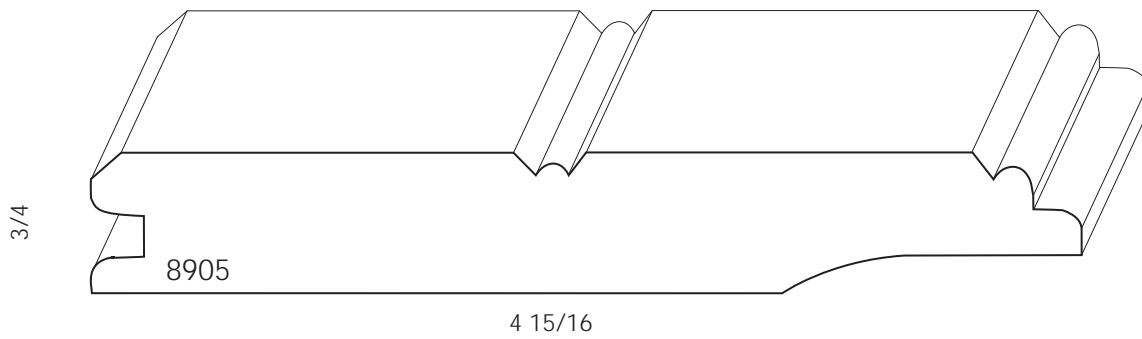
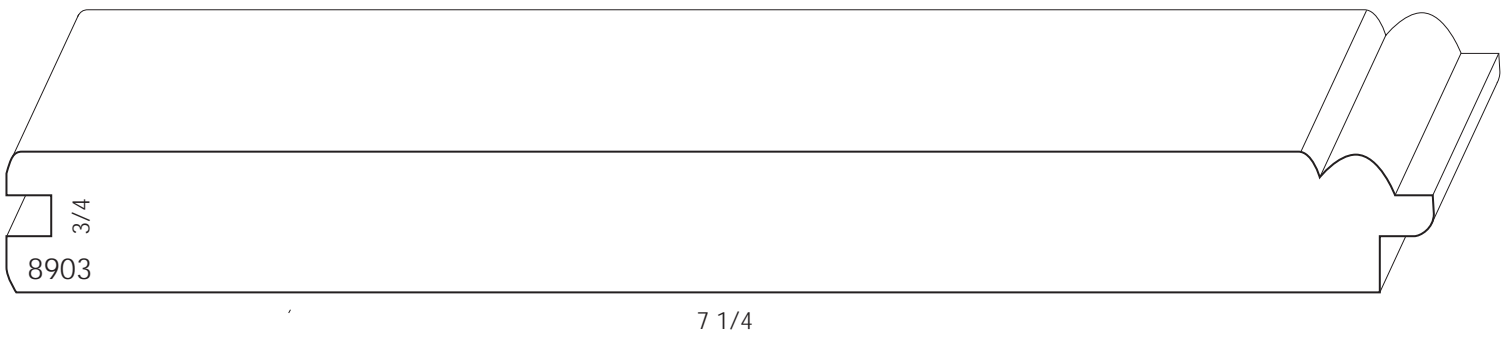
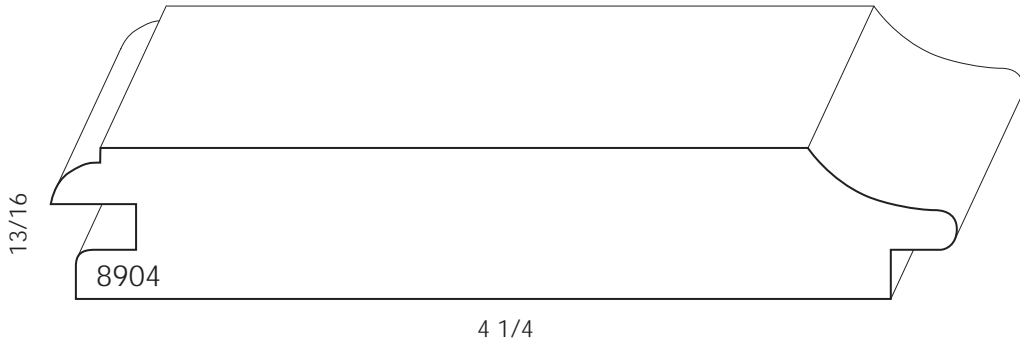
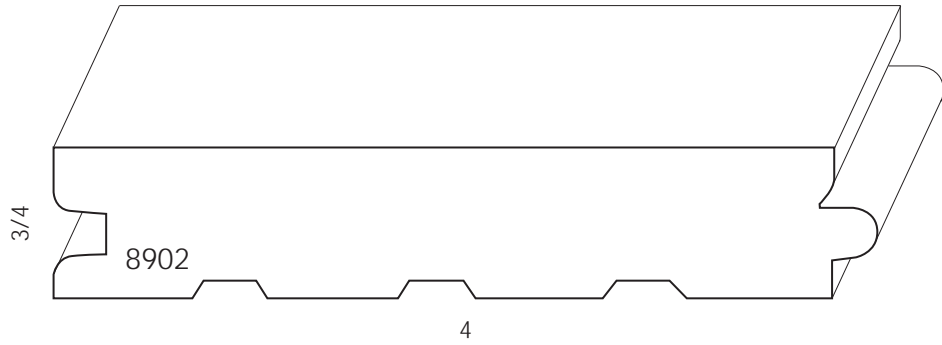

Tongue and Groove

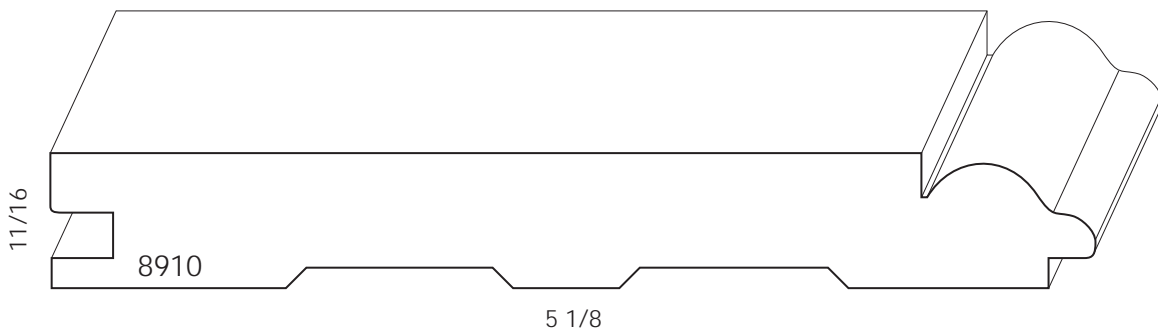
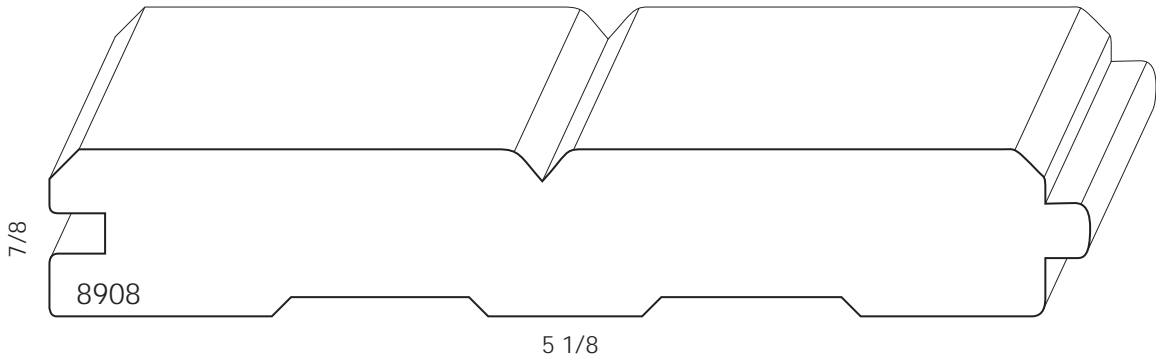
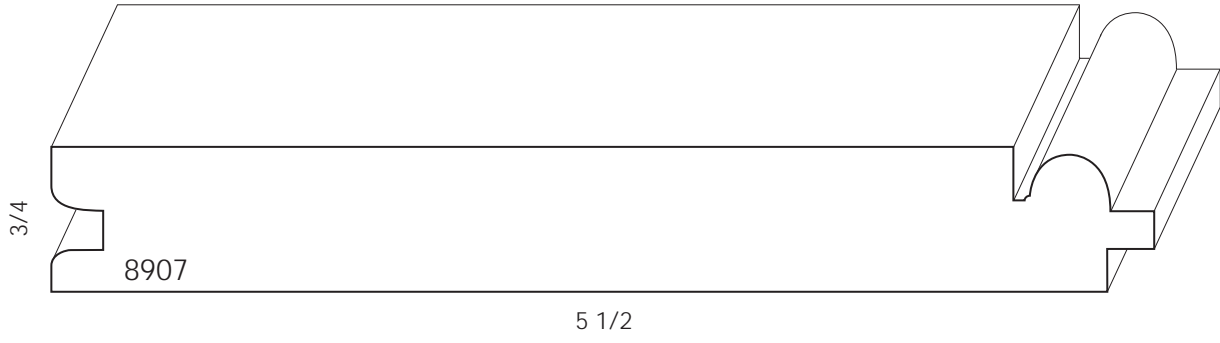
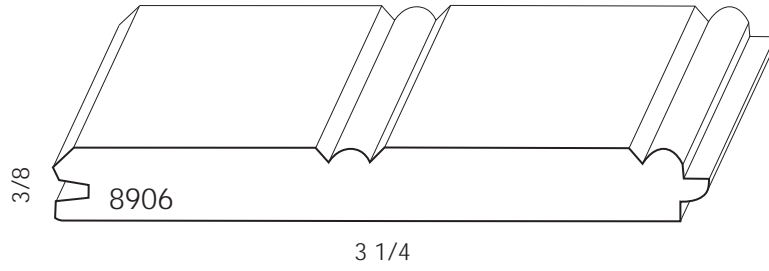

Tongue and Groove widths measure the exposed face only.

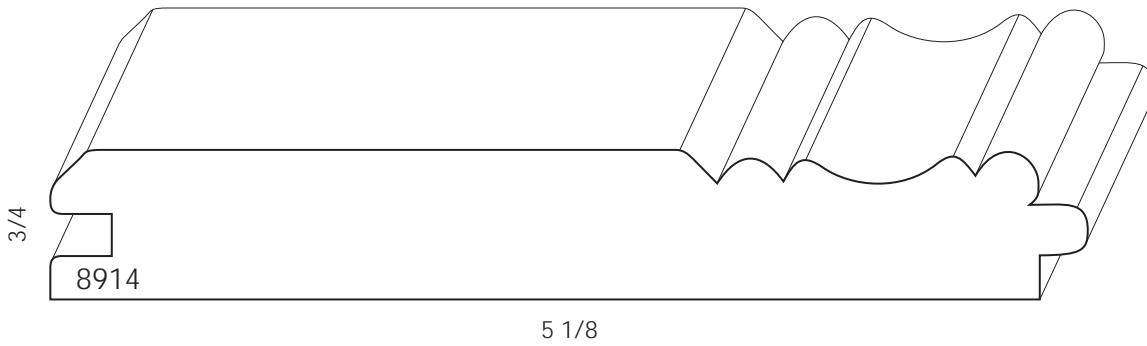
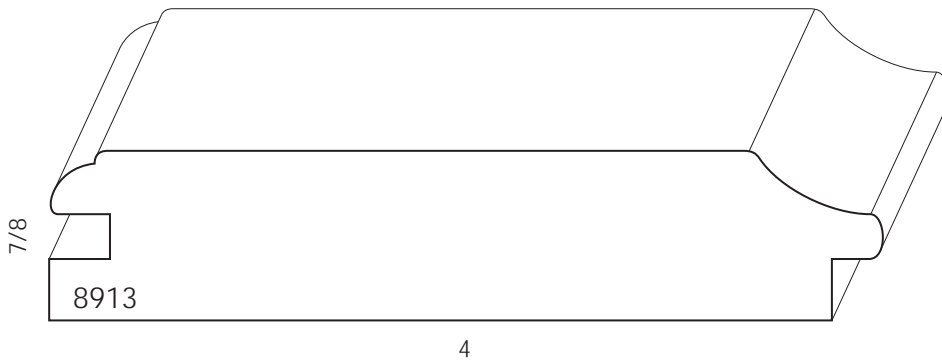
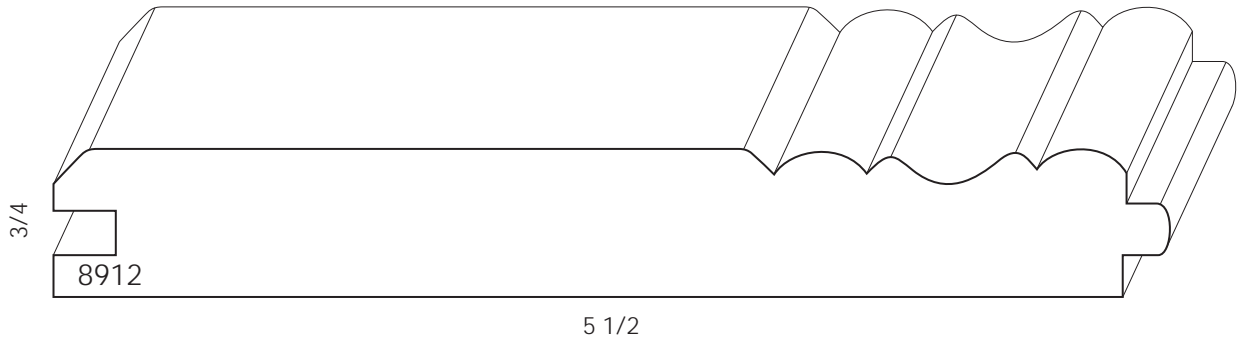
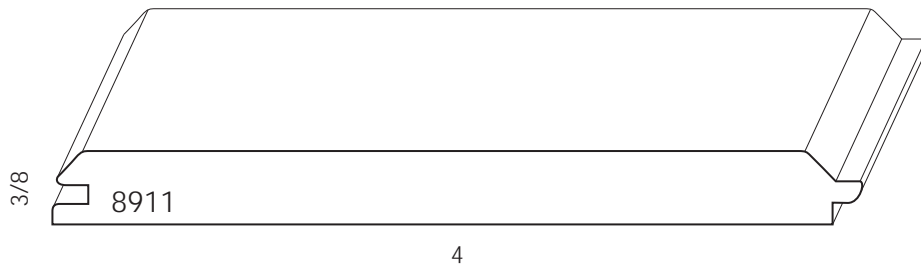

Tongue and Groove

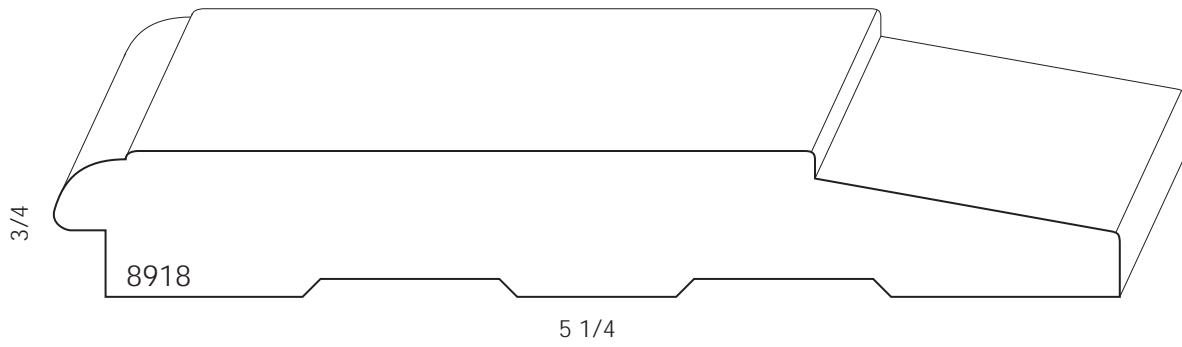

Tongue and Groove widths measure the exposed face only.

Tongue and Groove

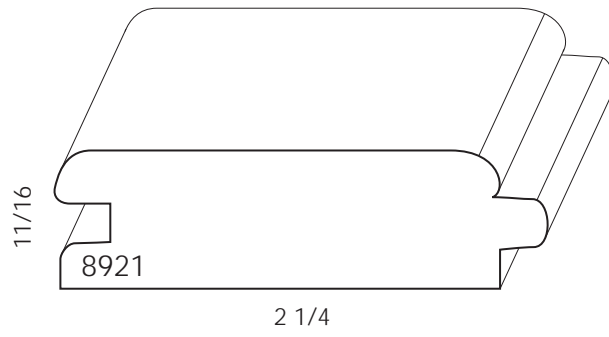
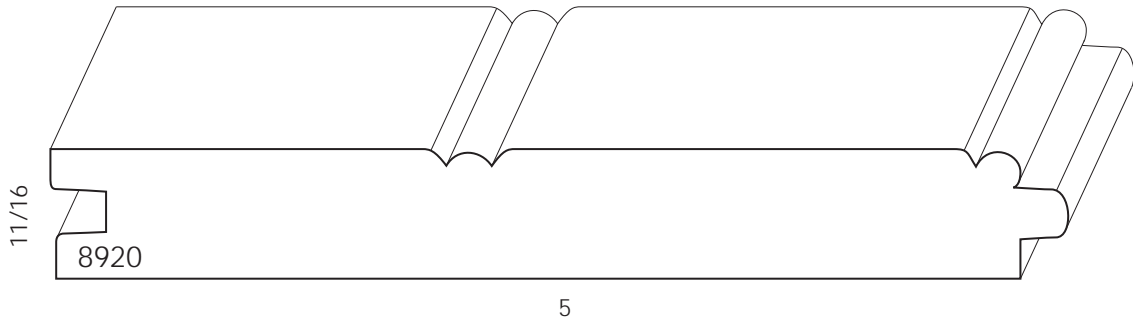

Window Sill

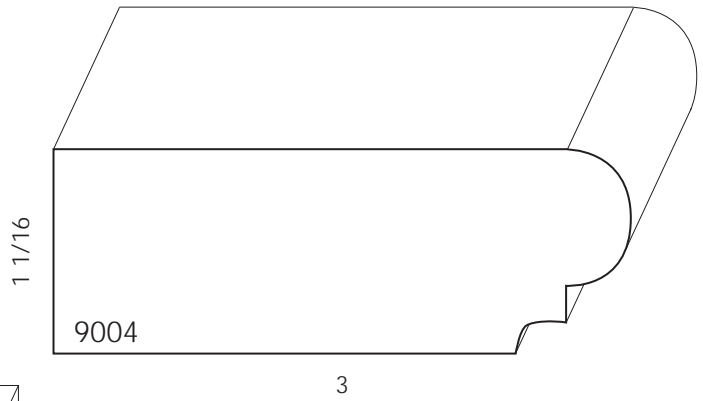
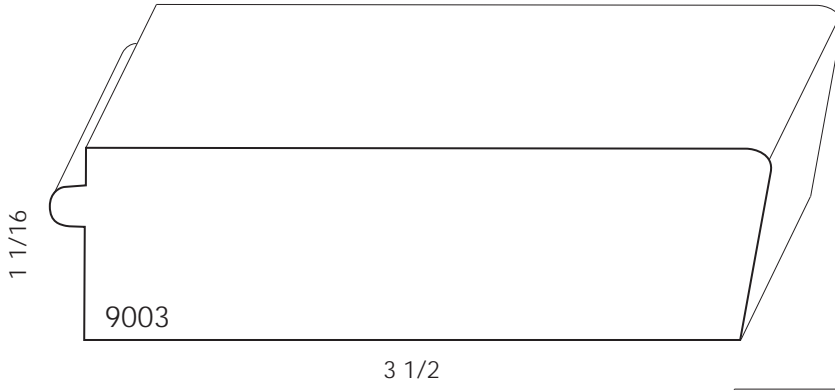
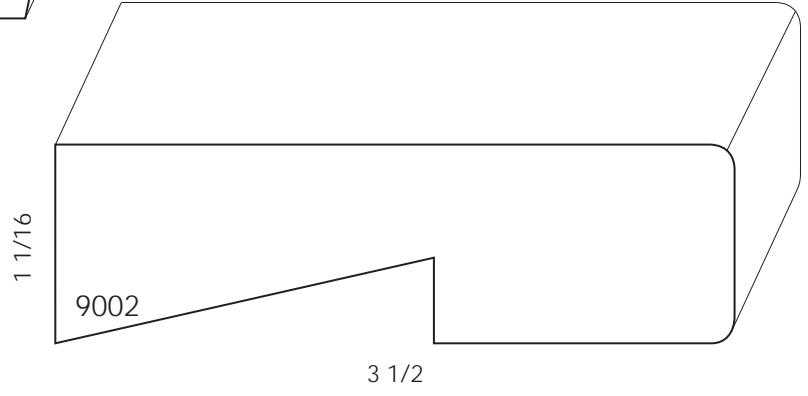
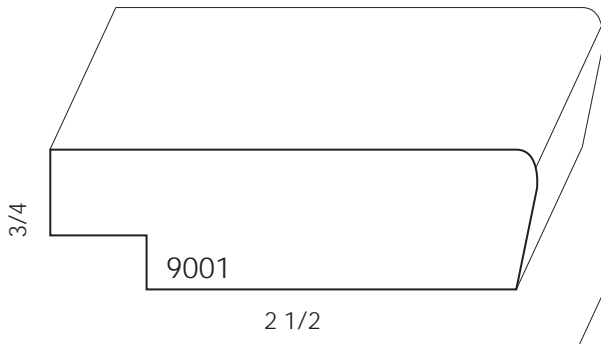

Window Sill can be ordered in custom widths.

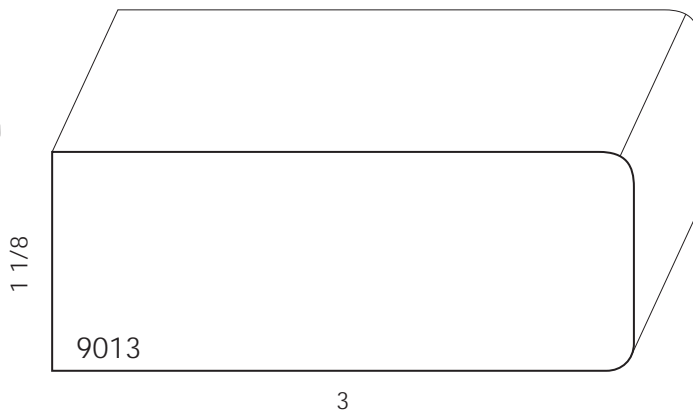
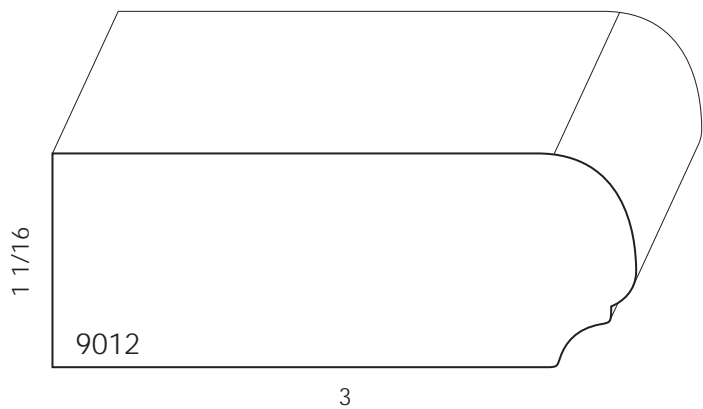
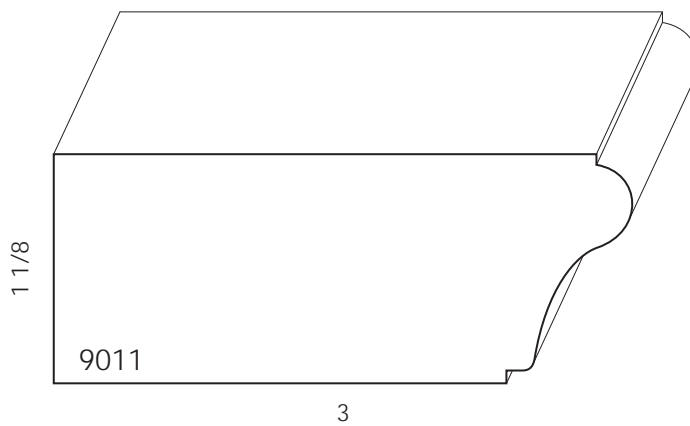
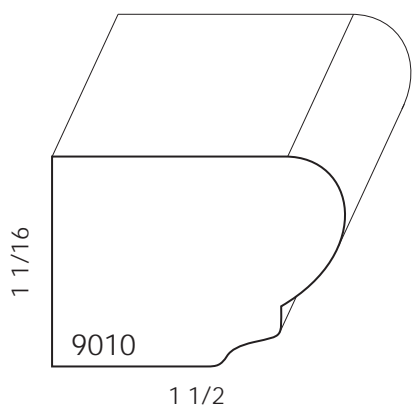
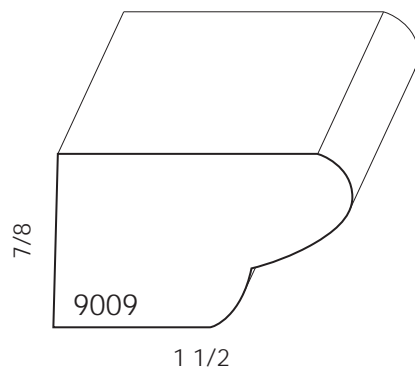
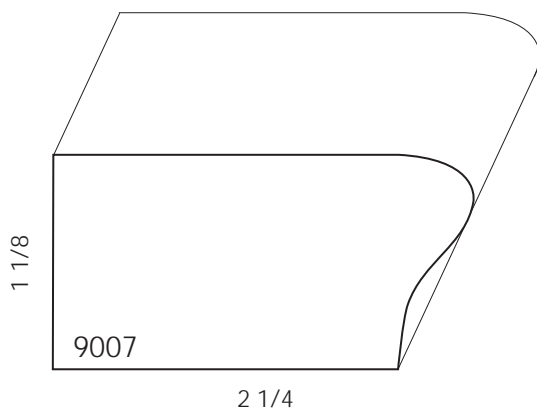
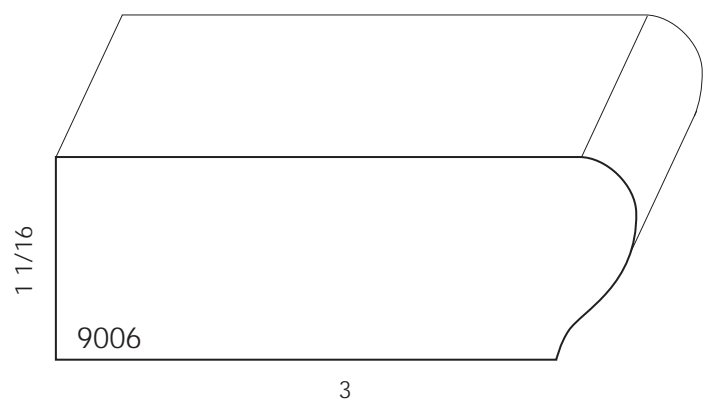

Nosing

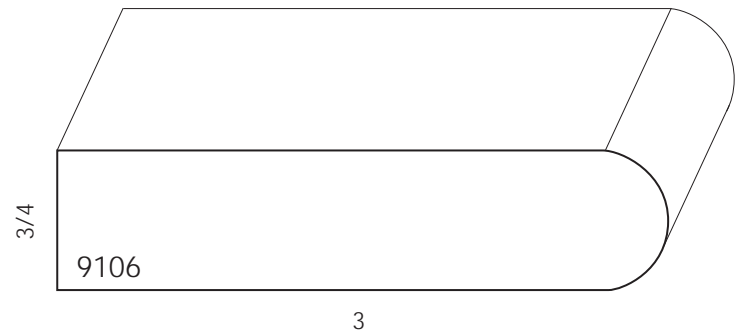
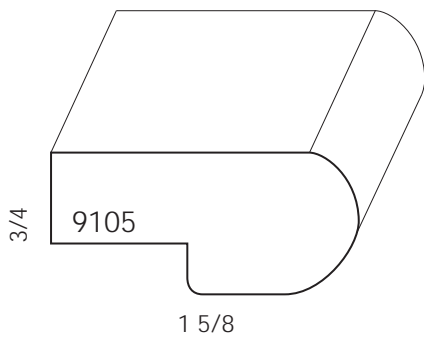
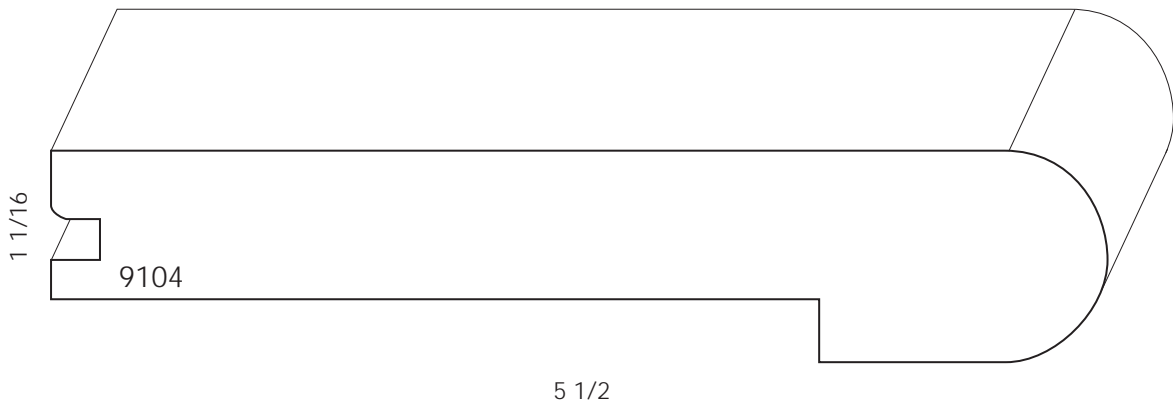
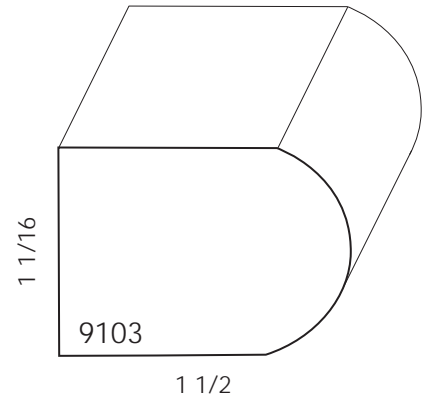
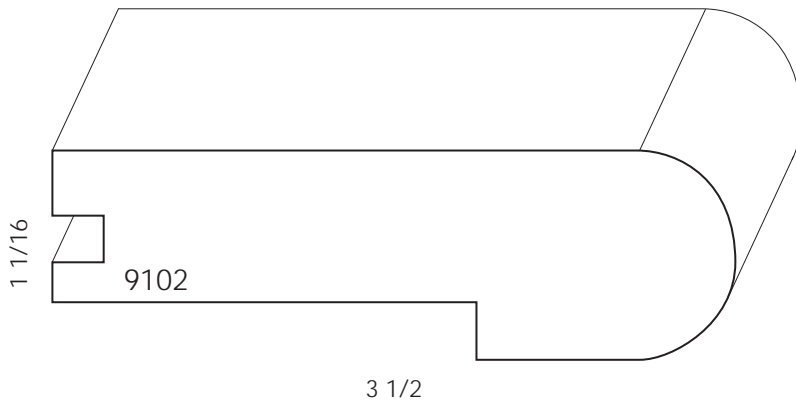
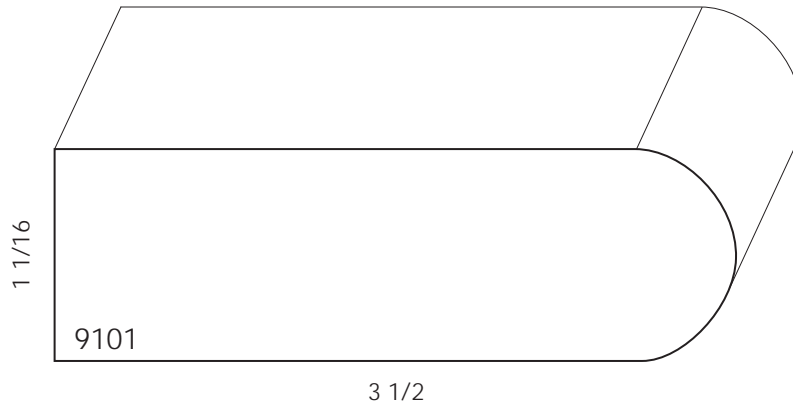

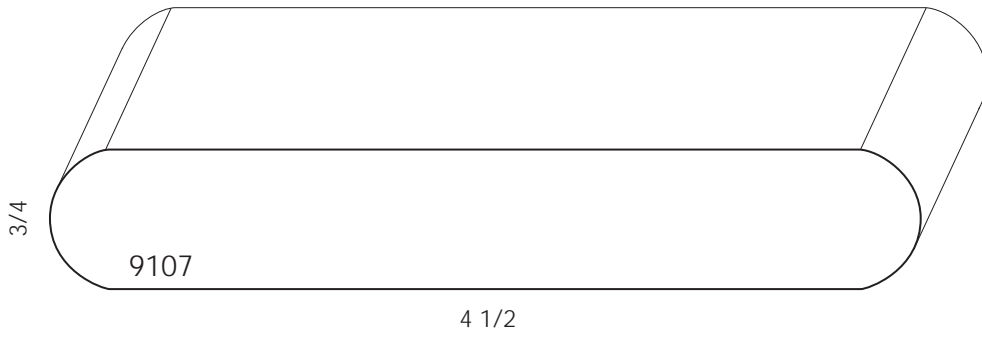

Nosing can be modified for custom overall and rabbet widths.

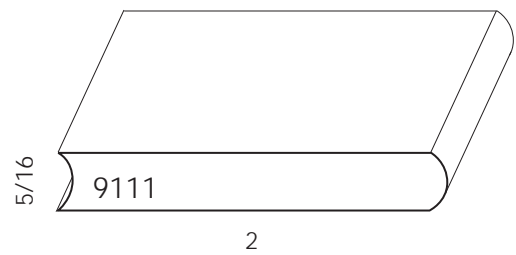
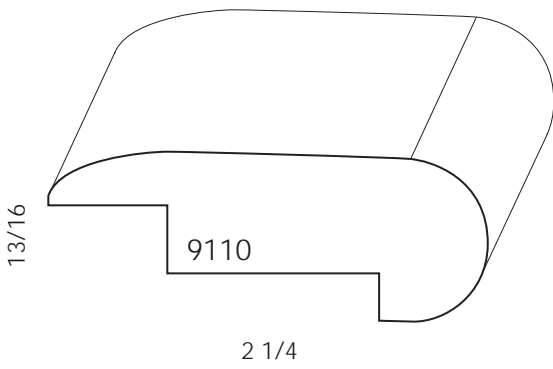
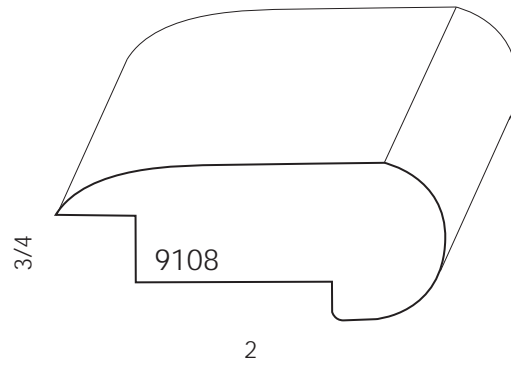

Nosing

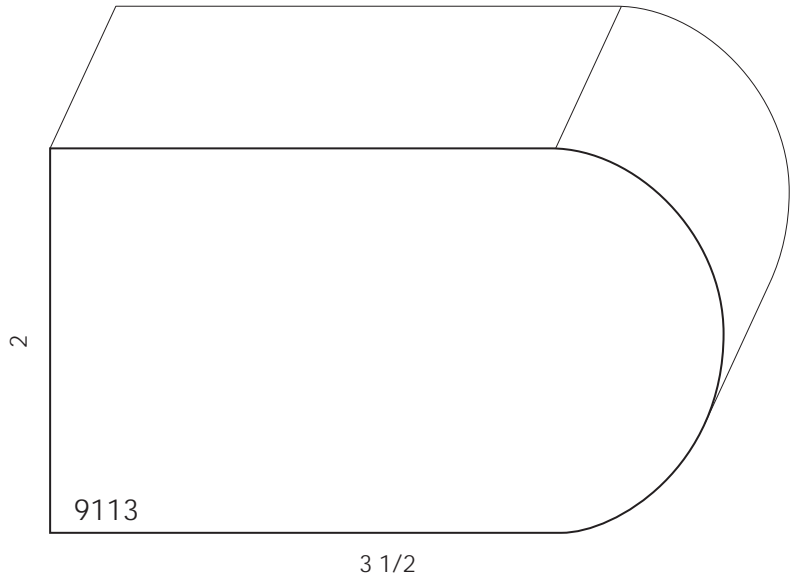
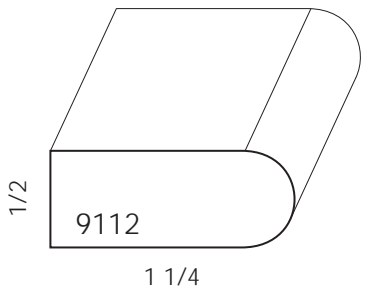

Nosing can be modified for custom overall and rabbet widths.

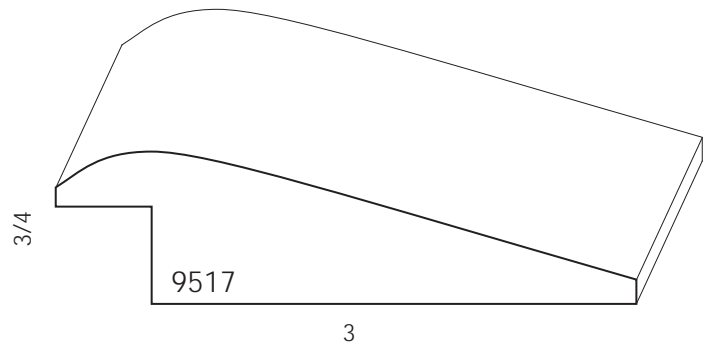
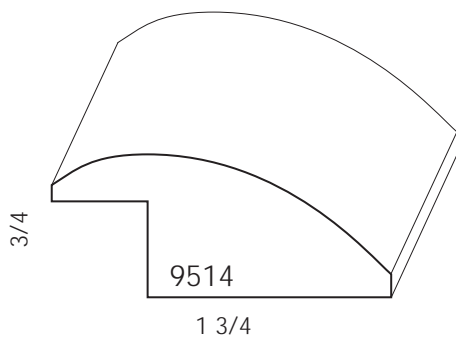
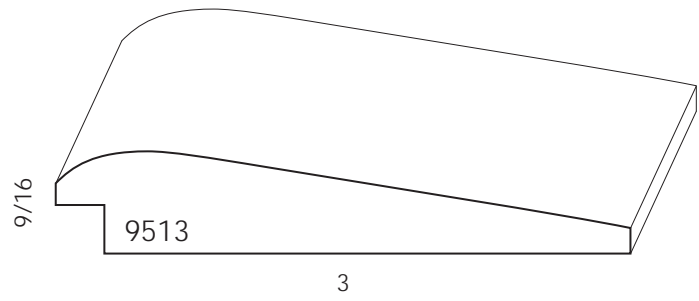
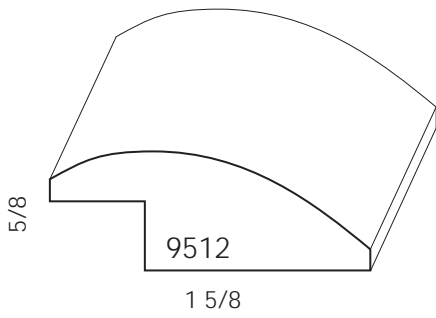
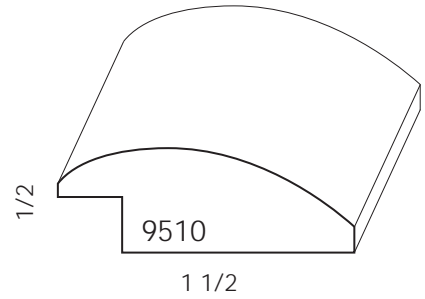
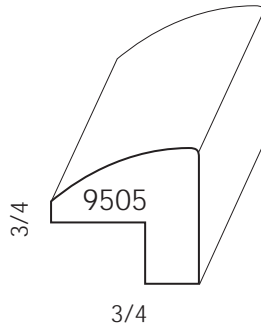
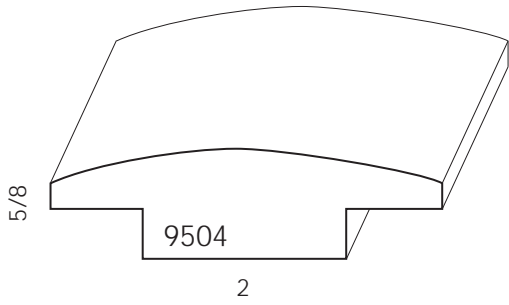
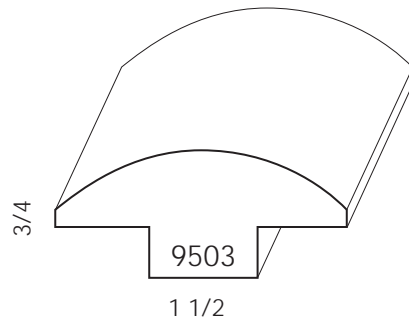
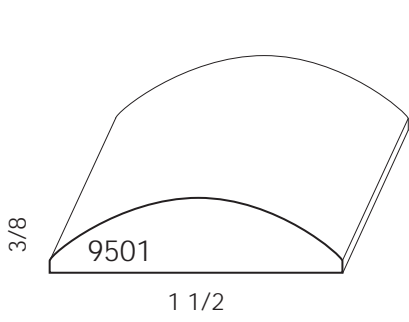

Most Transition Molds shown are inventoried in Red Oak.

Transition Mold

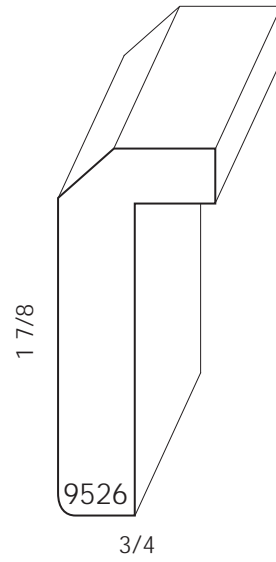
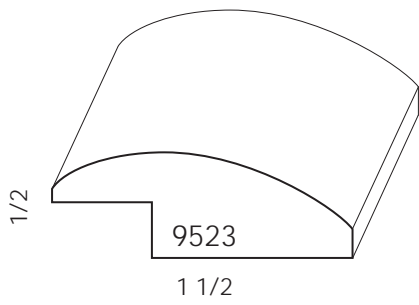
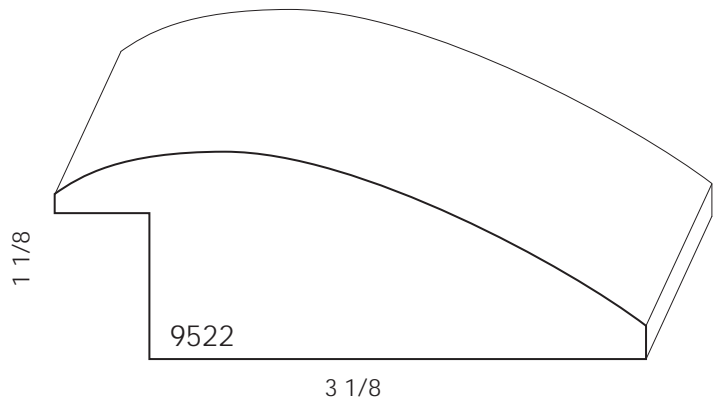
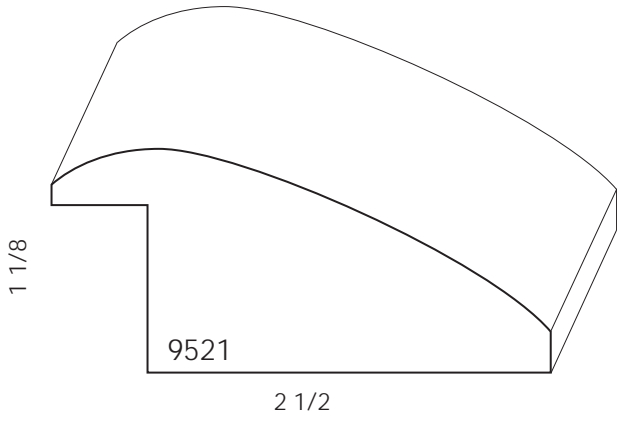
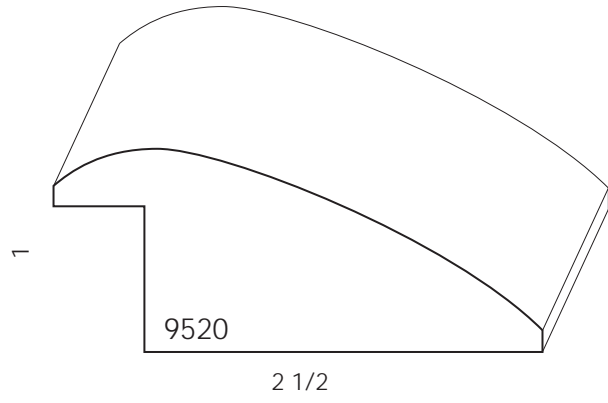
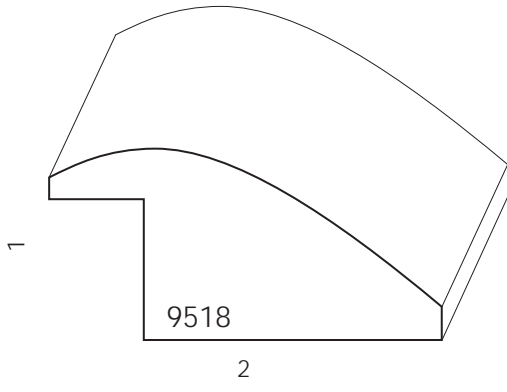

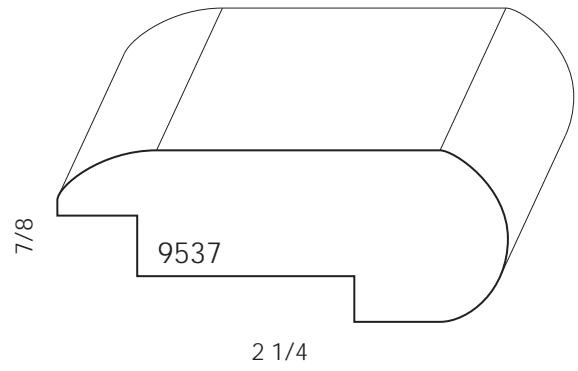
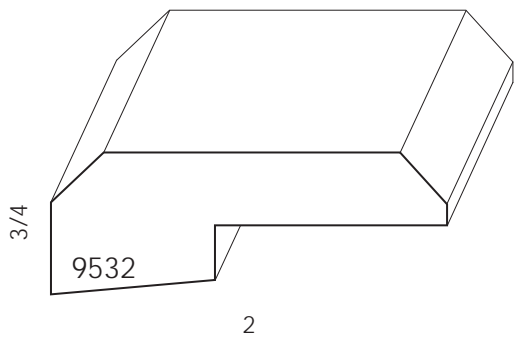
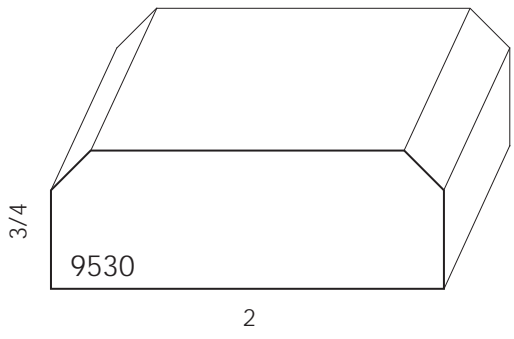

Most Transition Molds shown are inventoried in Red Oak.

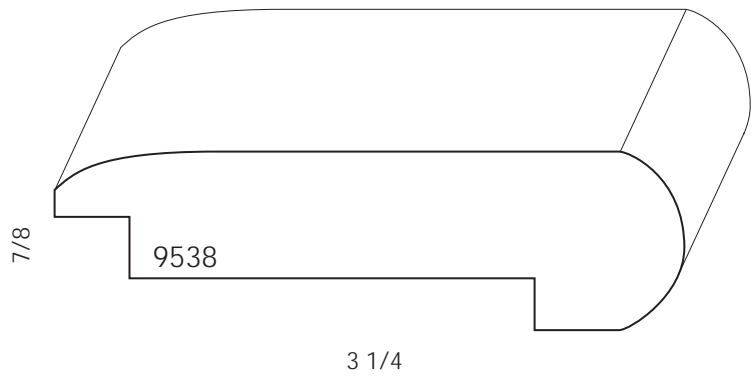

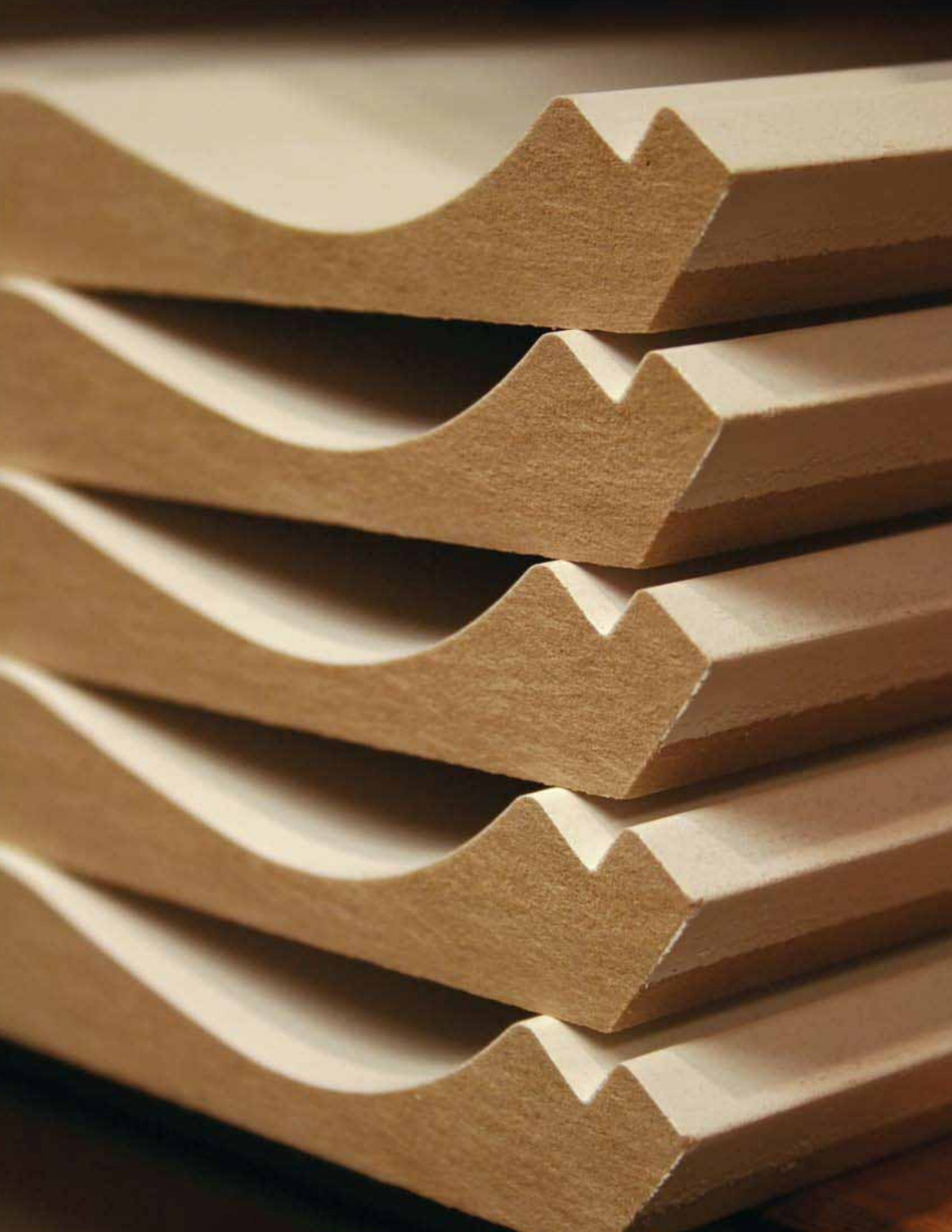

## Ultralight MDF

Ultralight Medium Density Fiberboard (MDF), composed of wood fibers from Radiata Pine combined with a synthetic resin and wax, is an ecologically sound product and an excellent substitute for solid wood mouldings.

## Ultralight MDF Qualities

- will not warp, crack or split
- ultra primed surface that requires less prep work
- requires no sanding which allows for deeper profiles
- no finger joints to break or raise through the finish
- creates less waste due to convenient 14'-16' lengths
- no "volcano" effect when nailing

## Handling

- always carry Ultralite MDF on edge as this will reduce stress caused by bending and flexing

## Finishing

- putty should be solvent based (spot prime area if using latex paints)
- use a slow dry acrylic latex caulk
- can apply a bead of caulk along the top edge of all base profiles, joints between lengths of mouldings, and all seams between crown mouldings (roof and wall)
- paint should be oil-based enamel gloss, semi-gloss acrylic latex gloss, or semi-gloss
- sand lightly between coats of paint for a superior finish

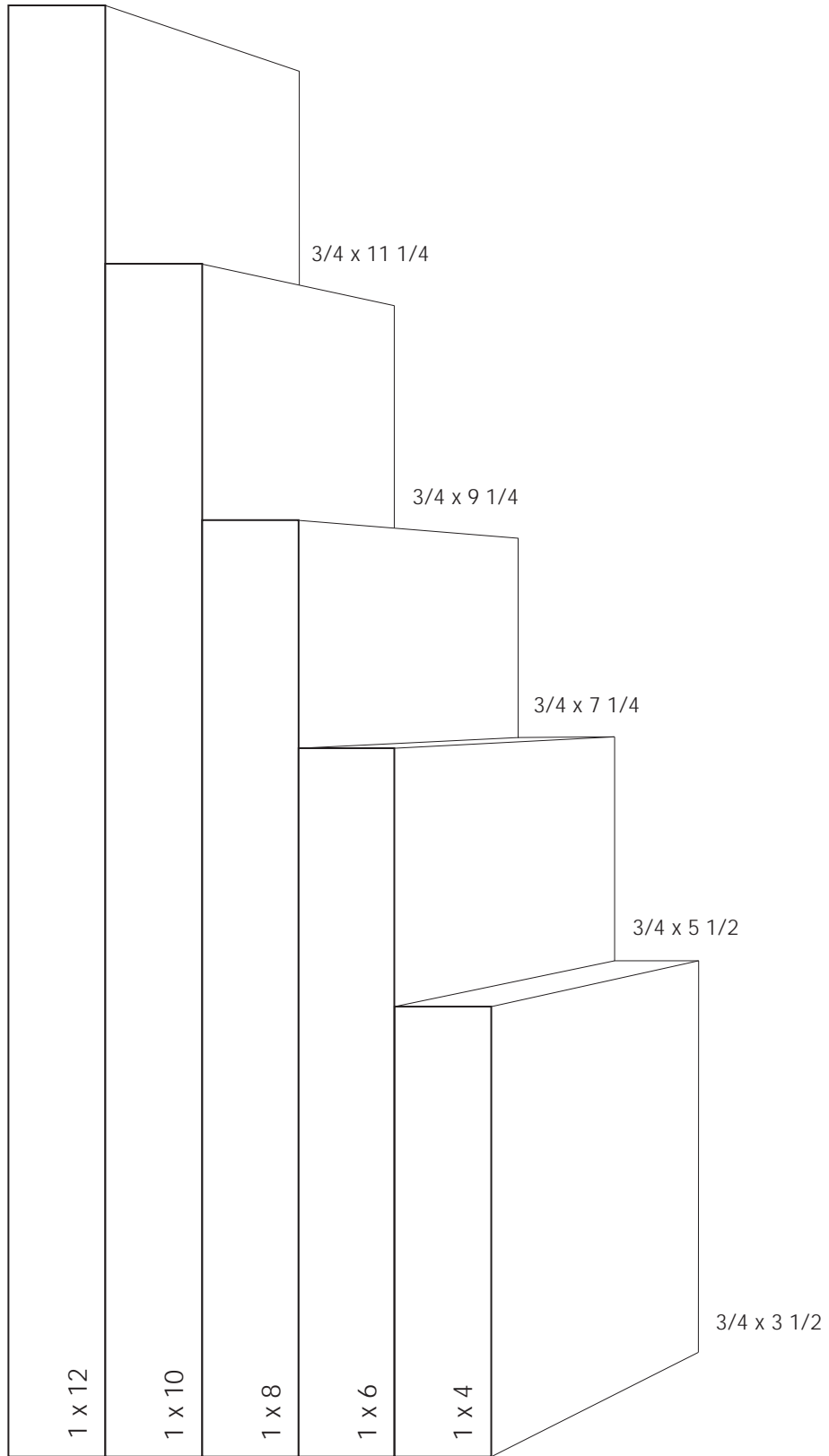

MDF Casing

[in stock]

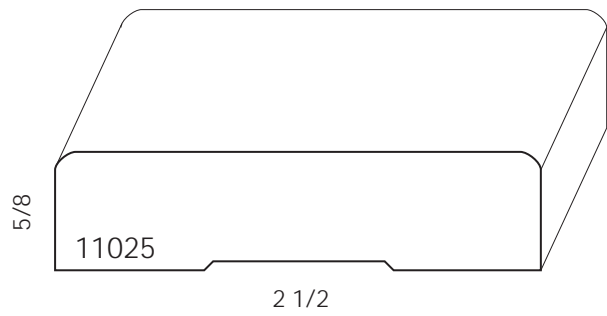
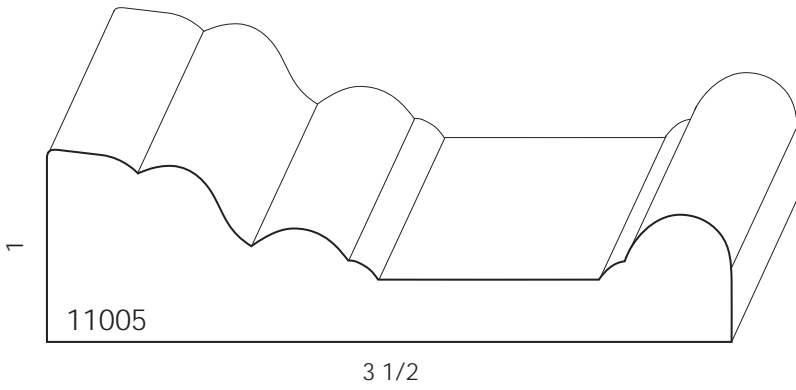
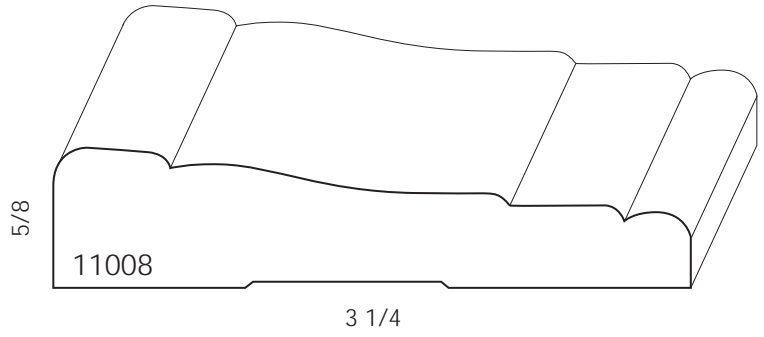
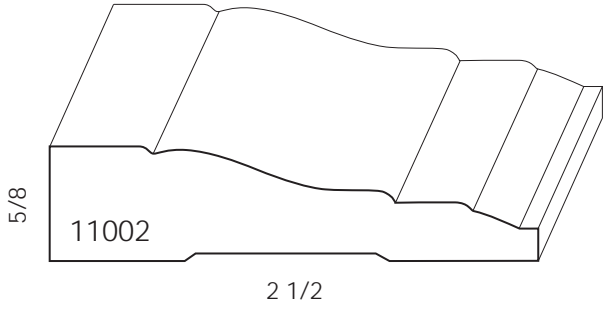

MDF Base  
[in stock]

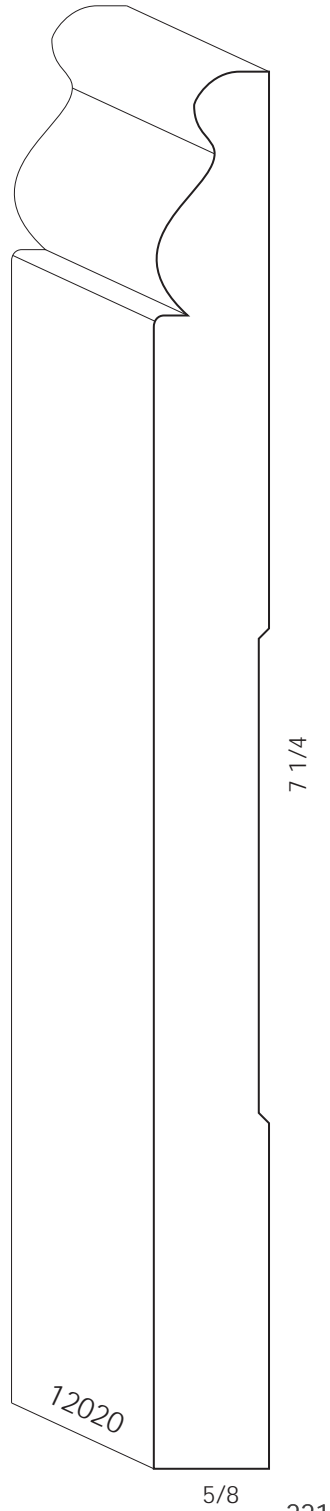
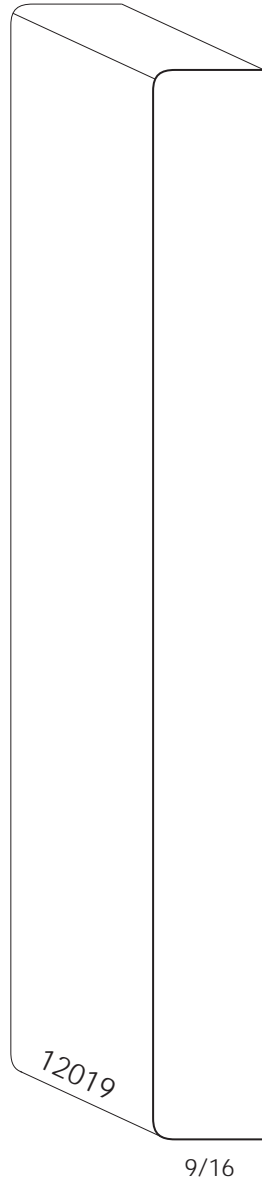
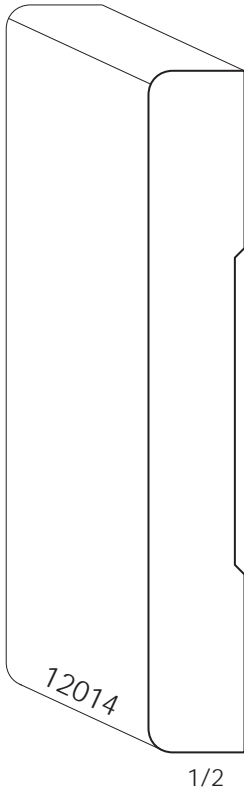
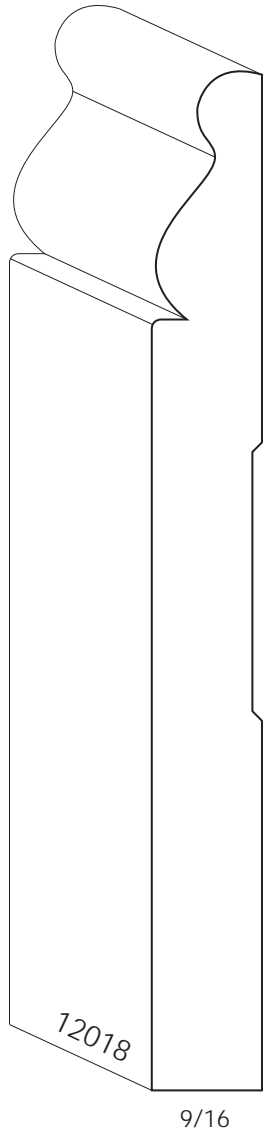
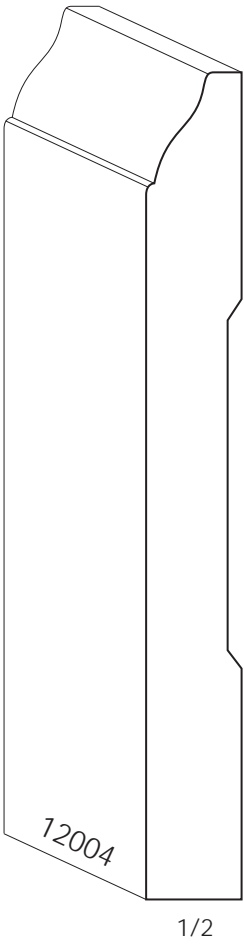

MDF Crown

[in stock]

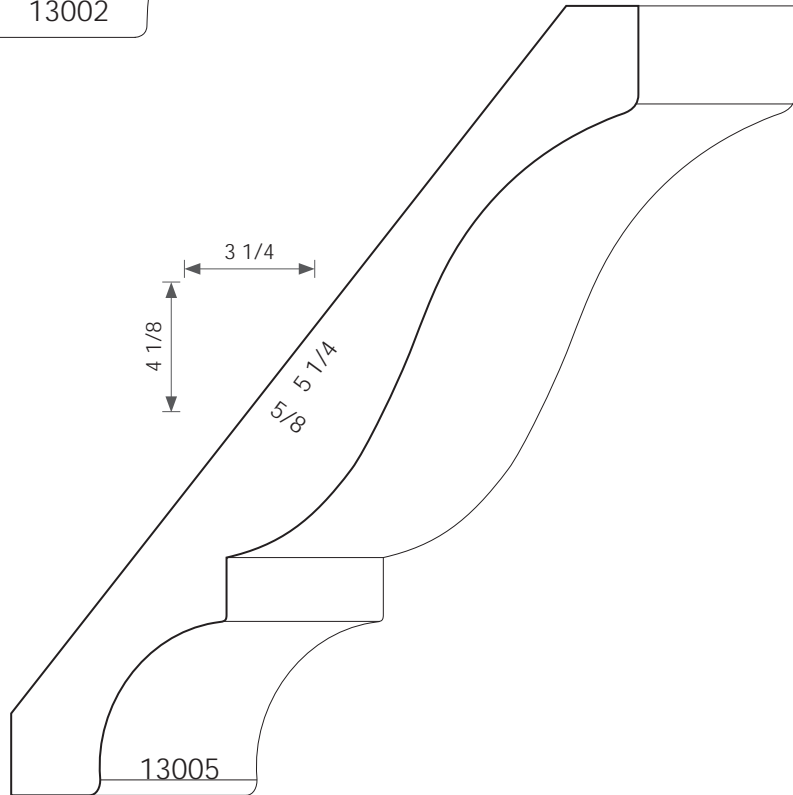
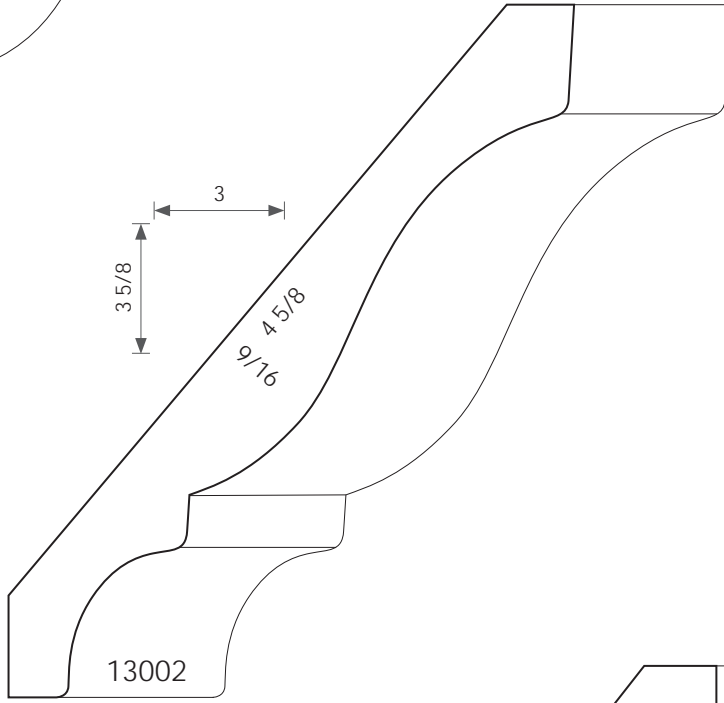
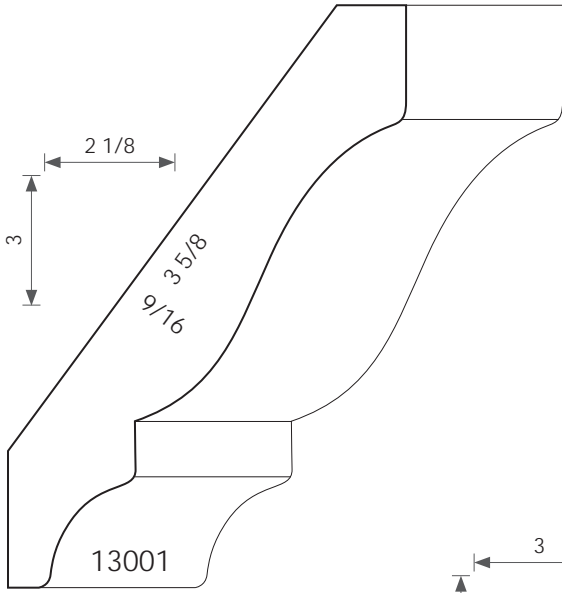

MDF Base  
[in stock]

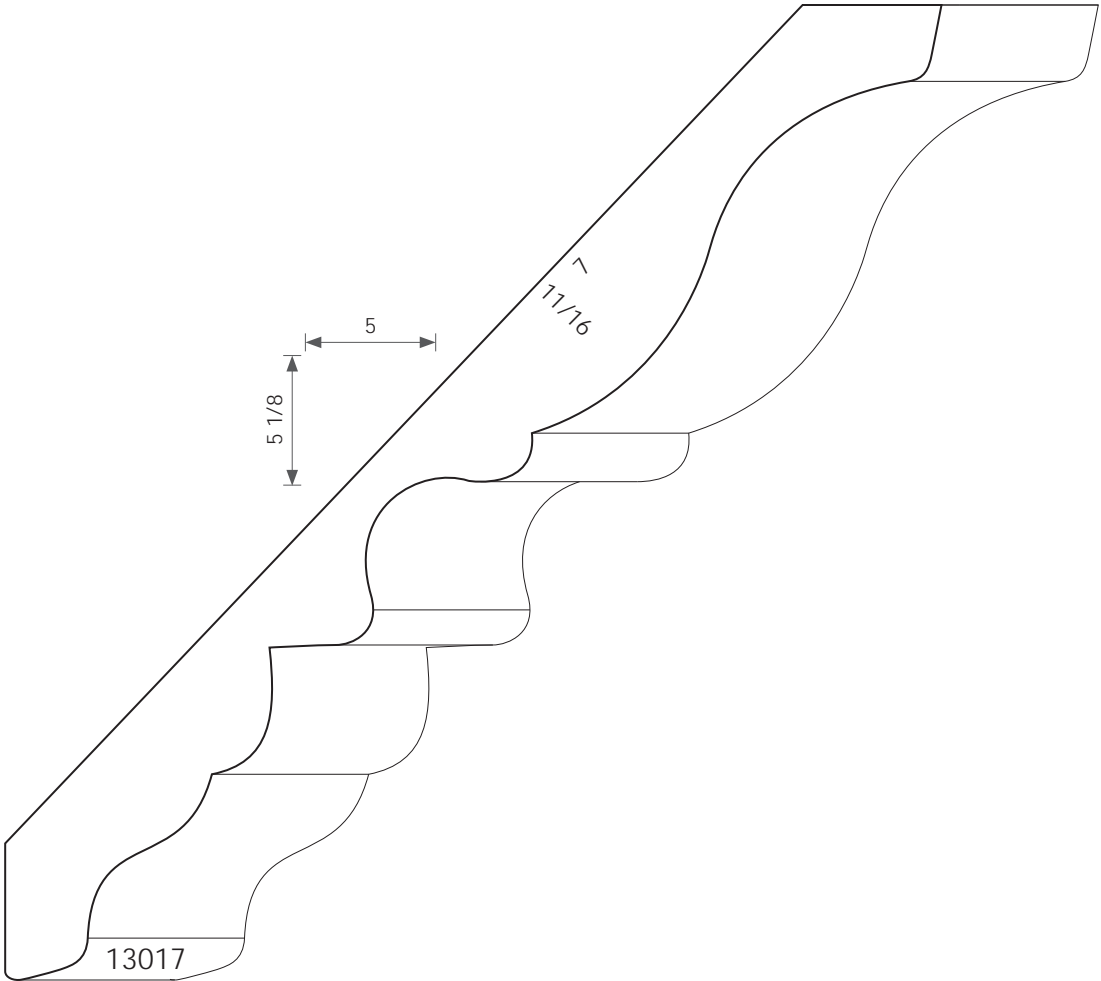

MDF Casing

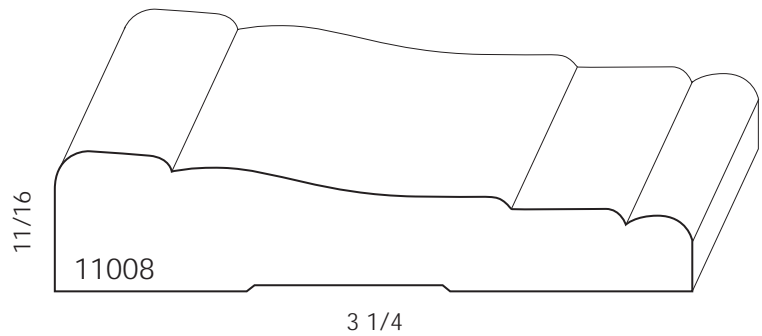
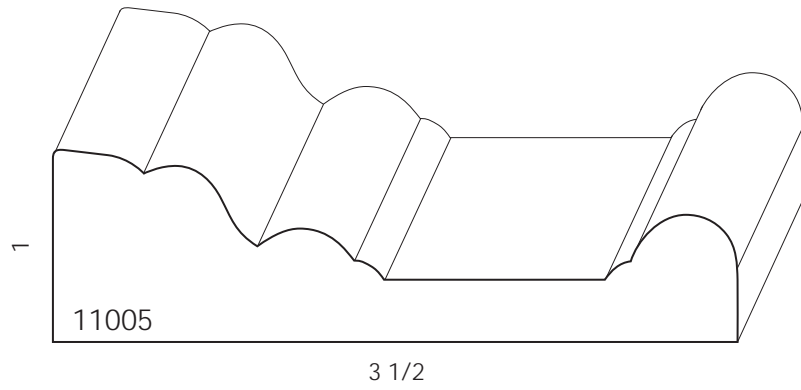
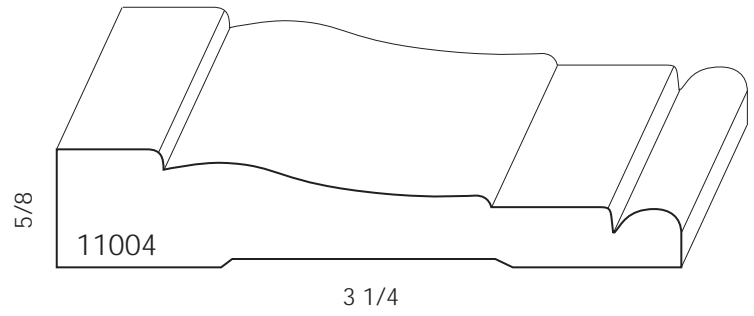
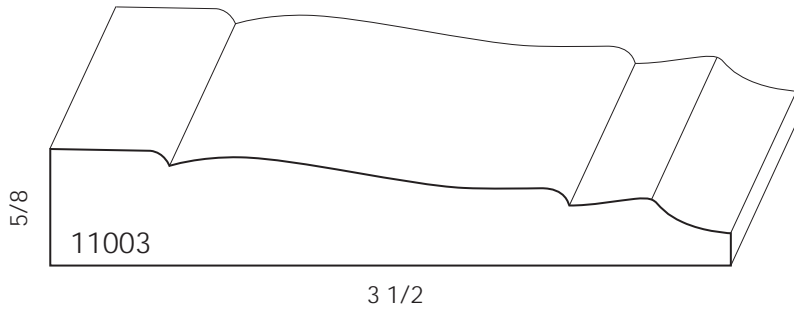
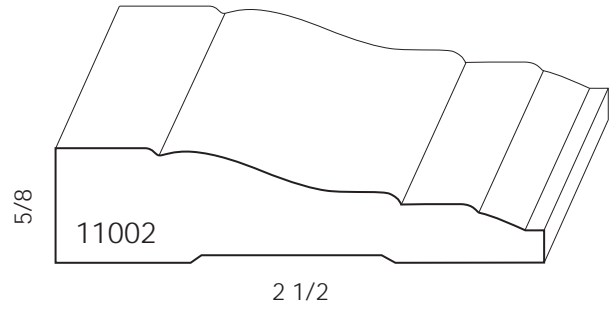
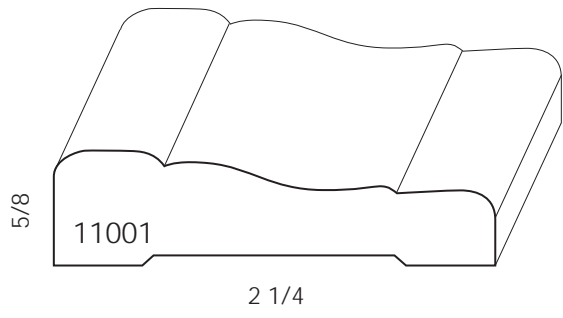

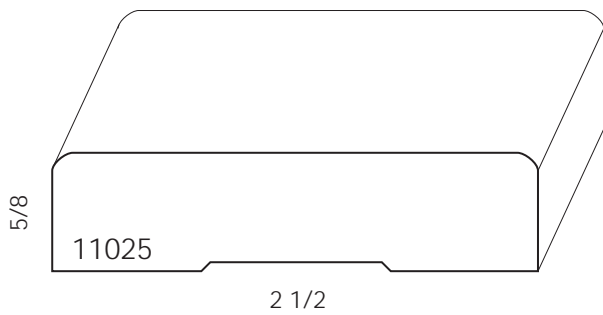
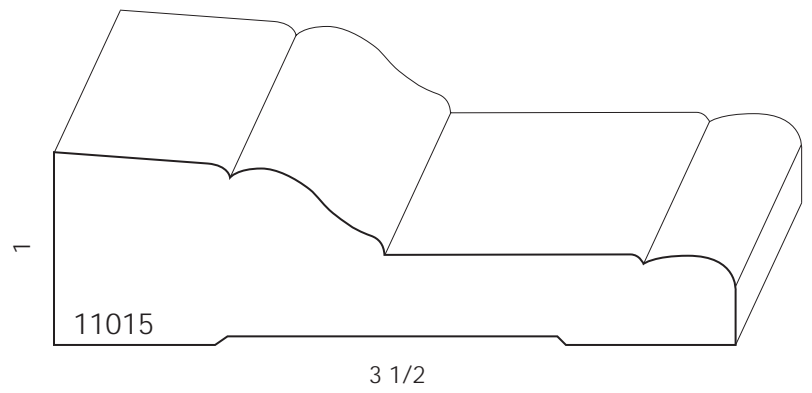
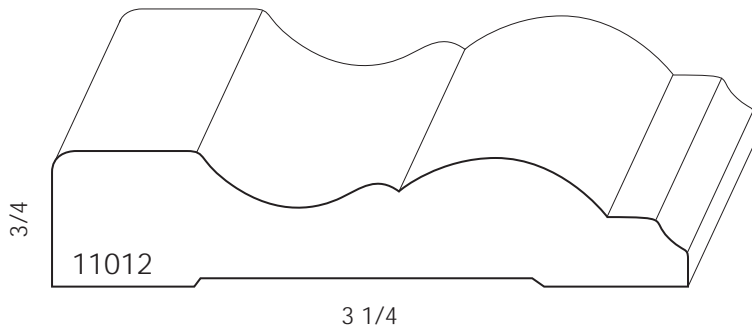
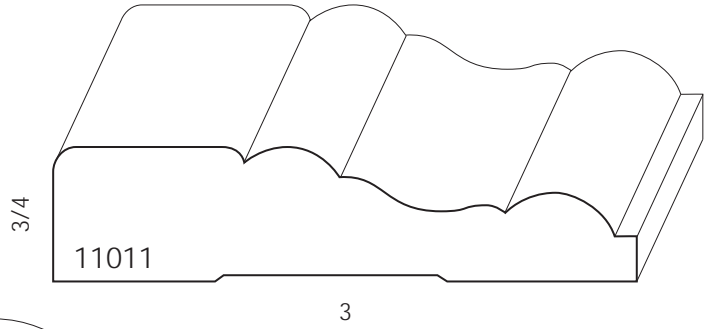
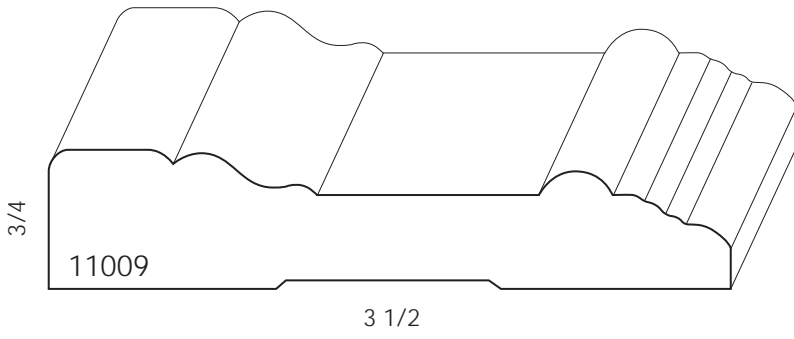

MDF Casing

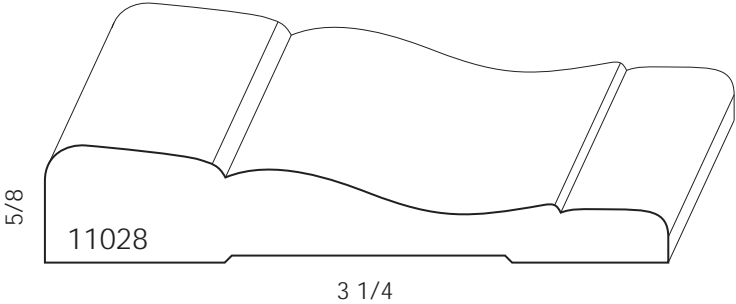
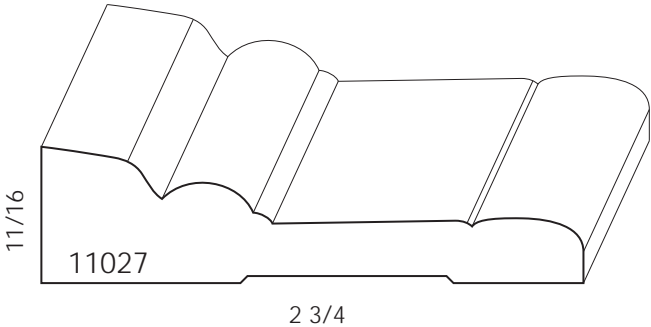
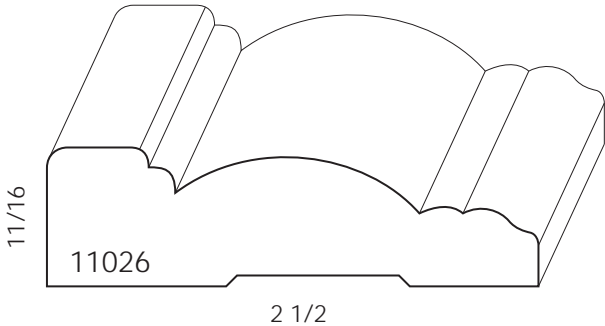

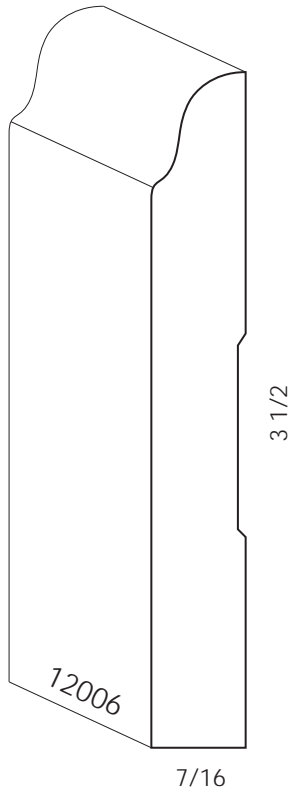
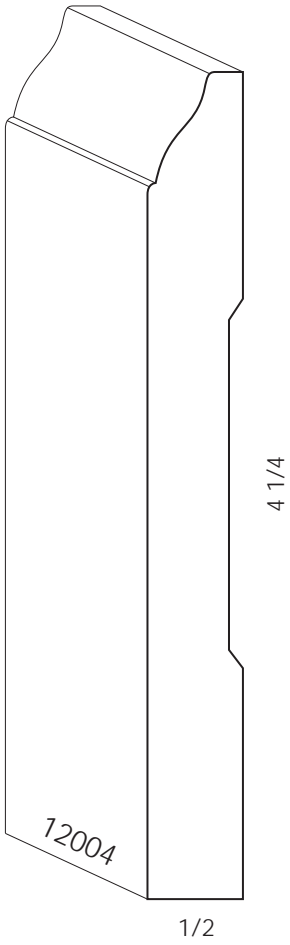
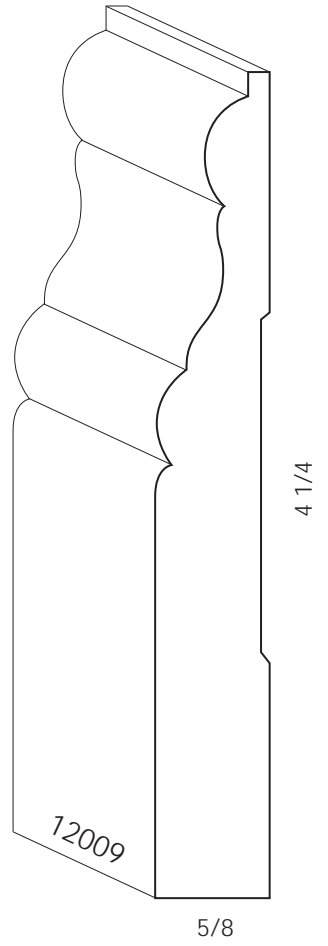
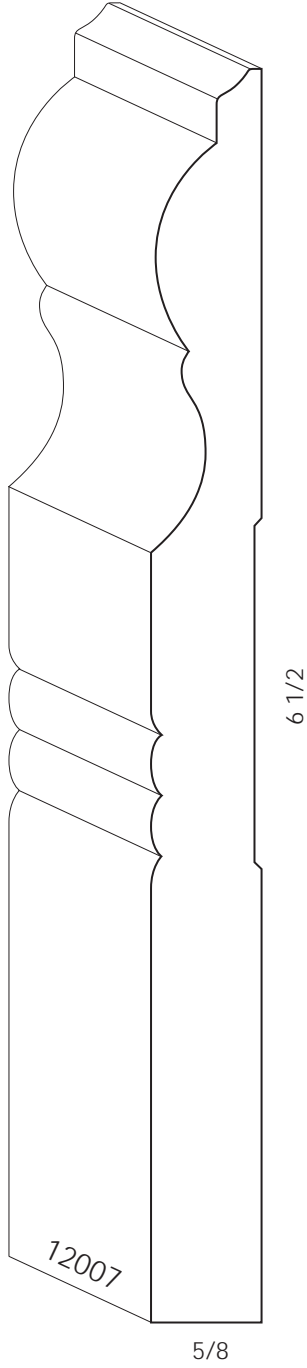
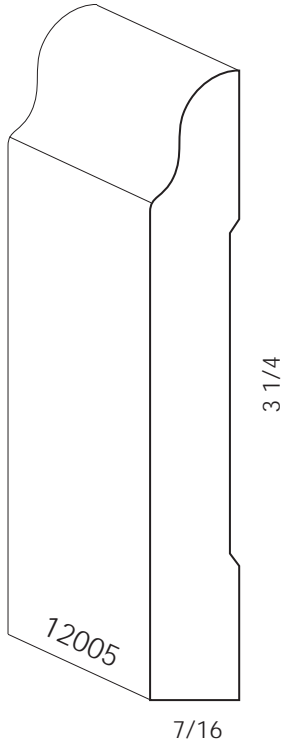
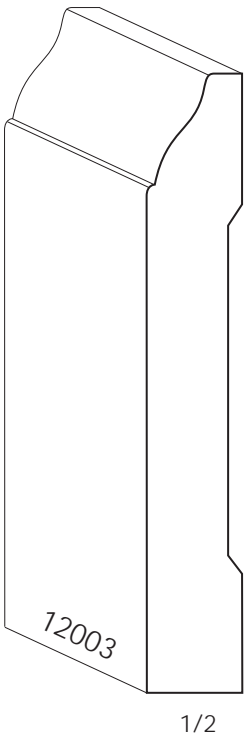

MDF Base

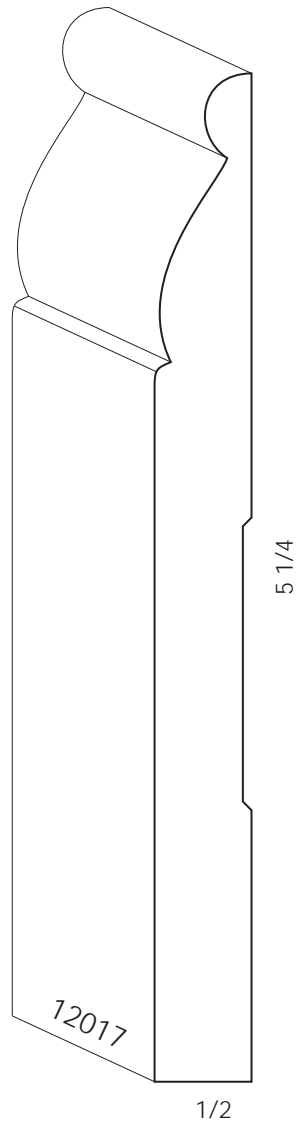
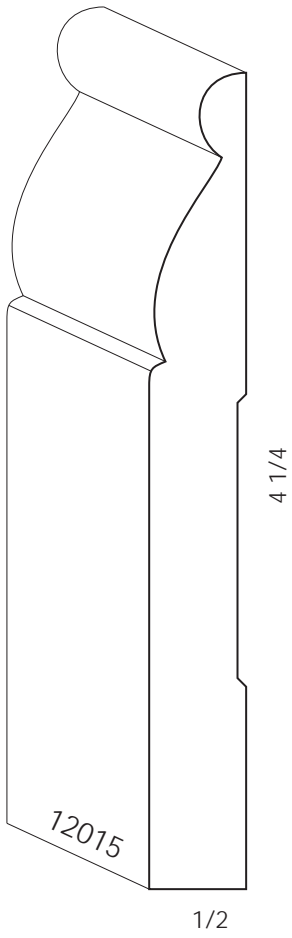
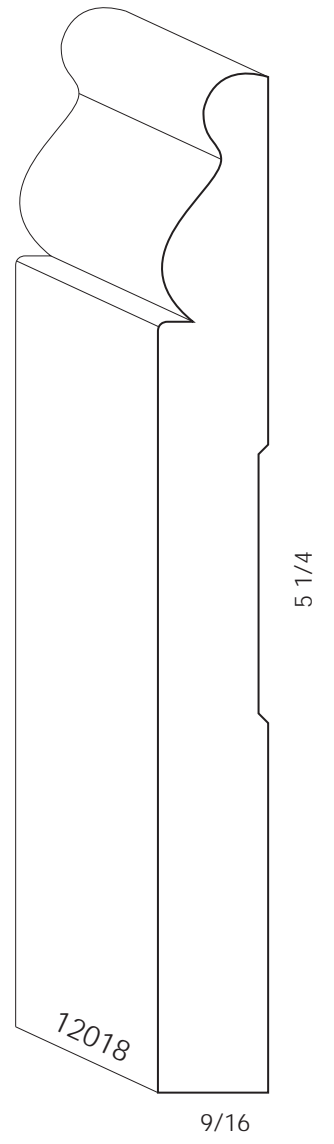
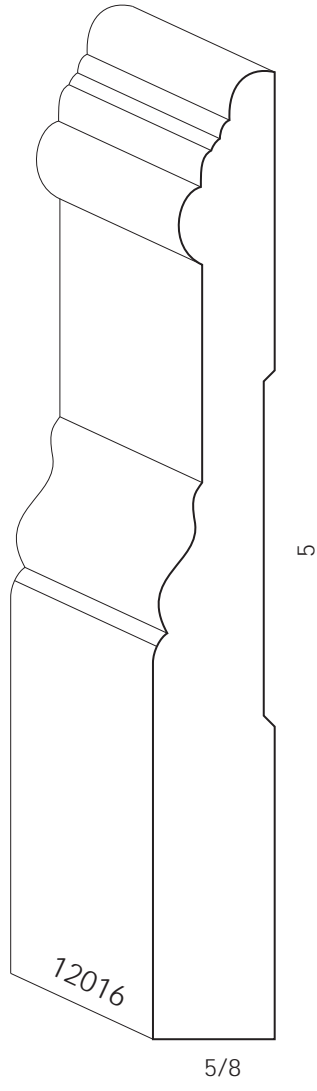
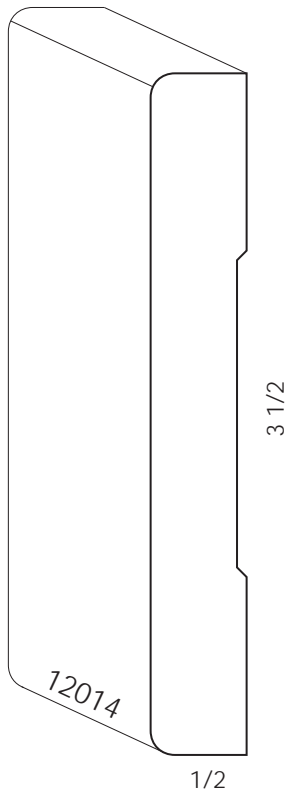

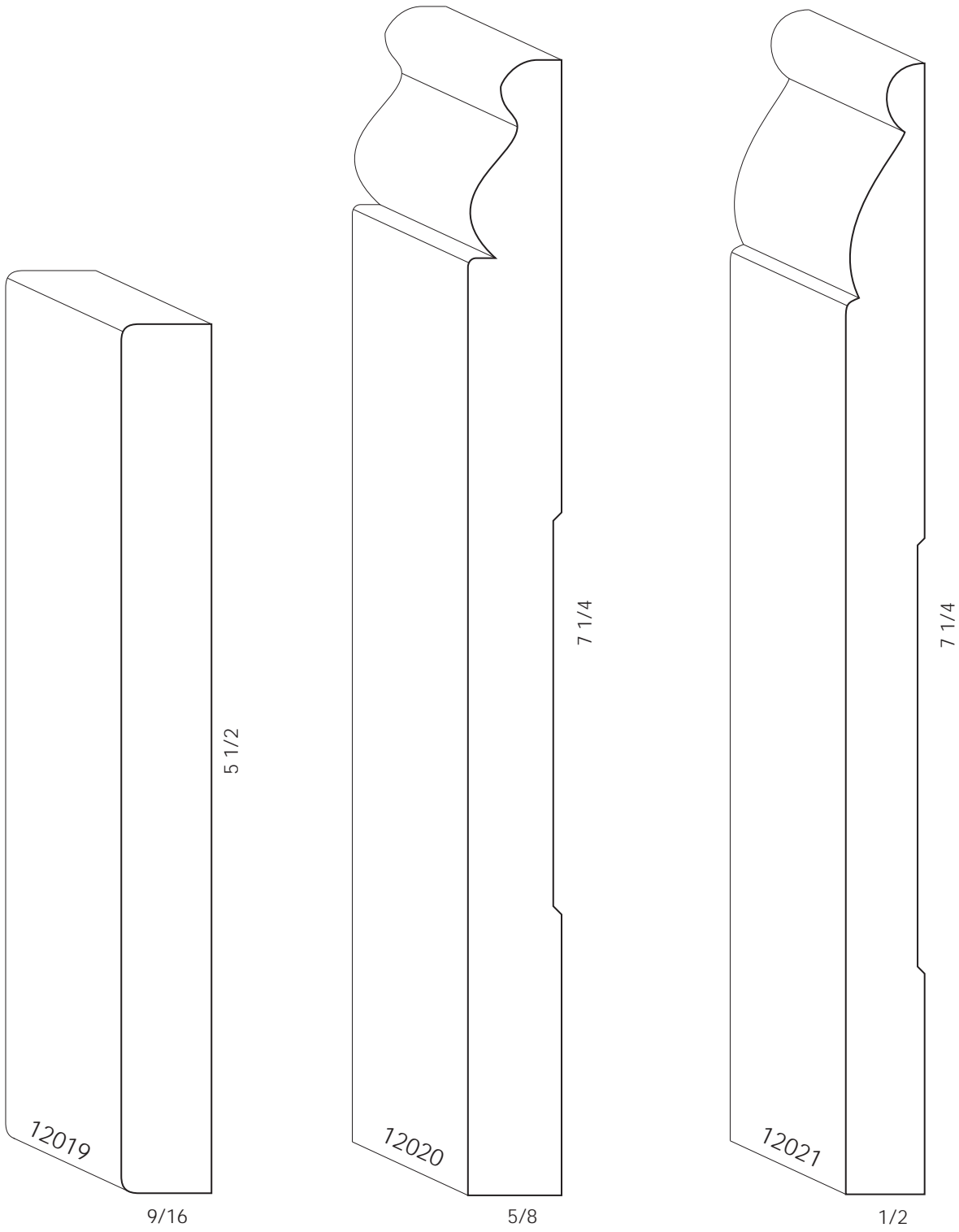

MDF Crown

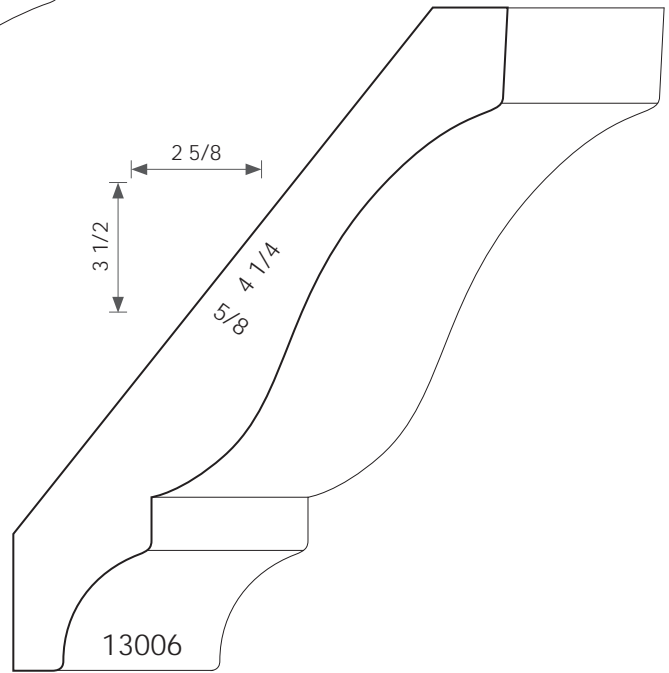
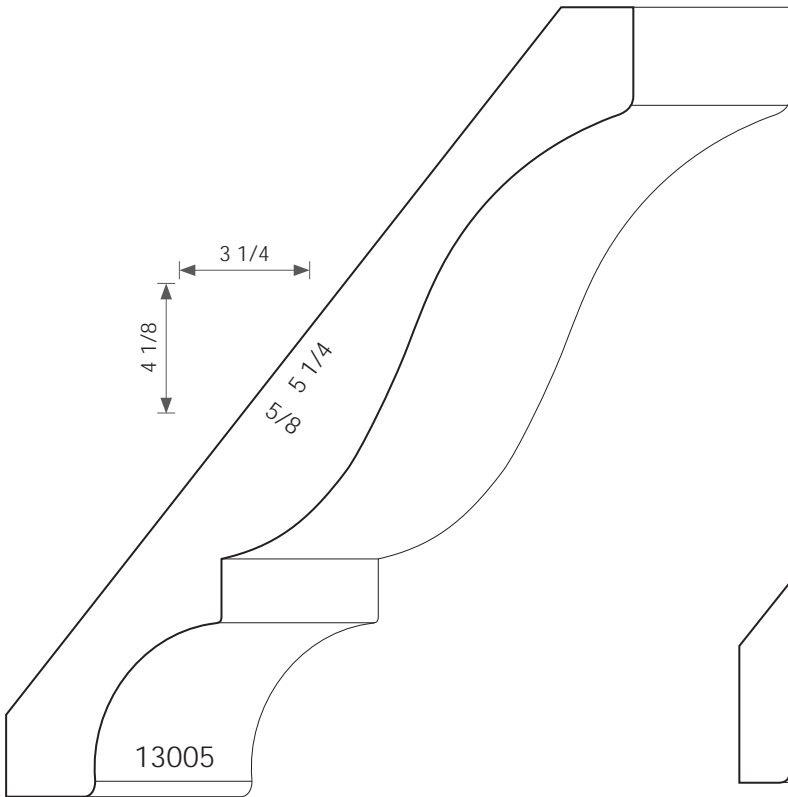
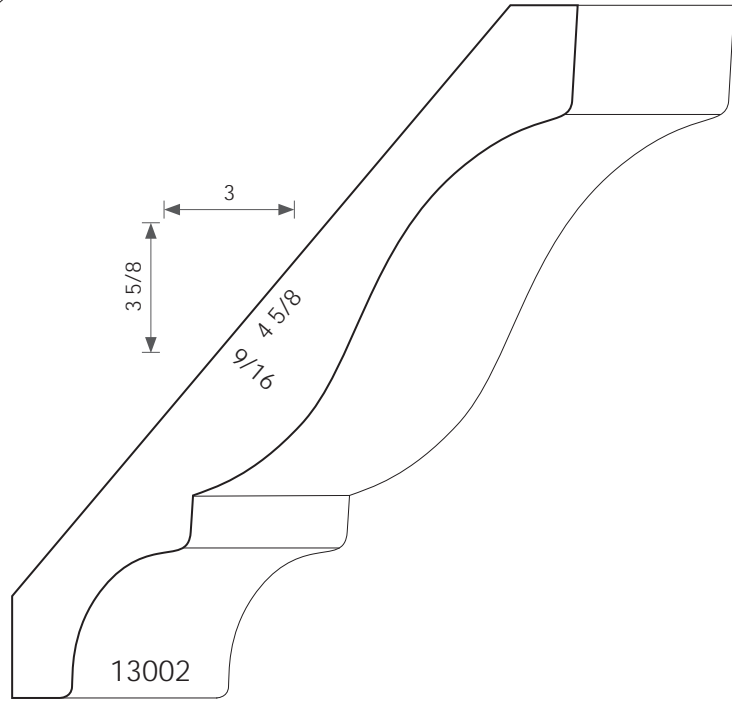
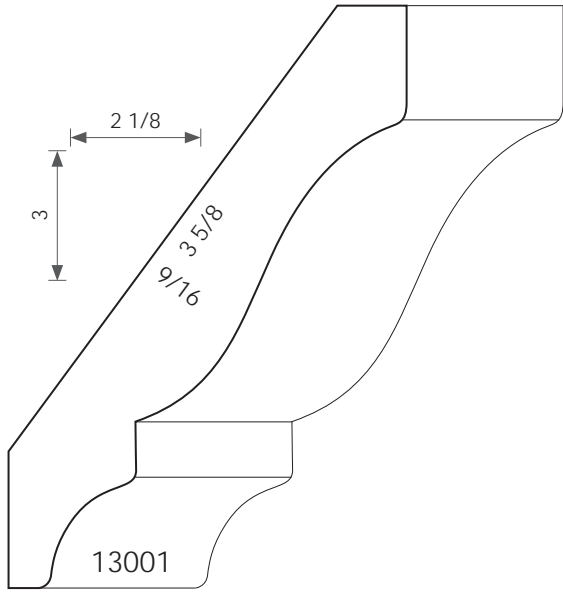

MDF Crown

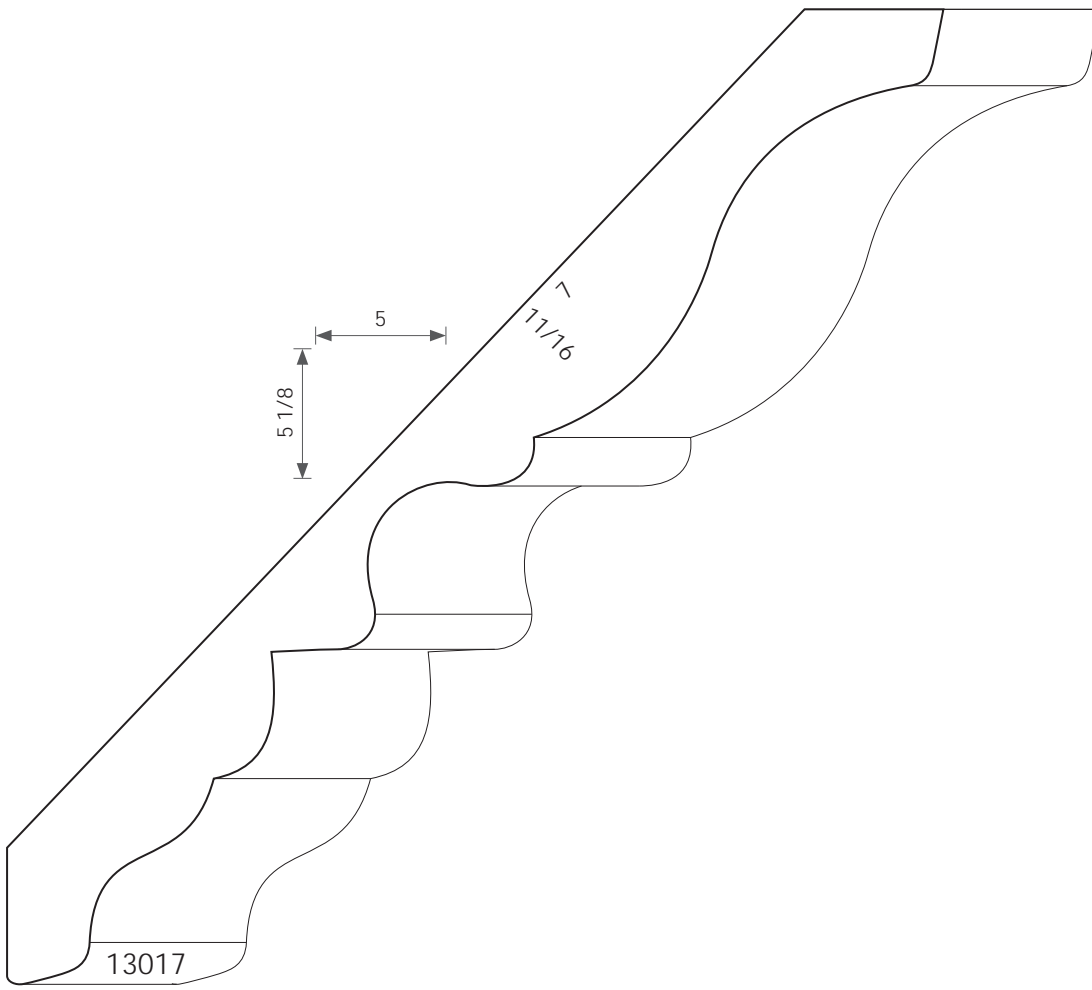

MDF Chair Rail

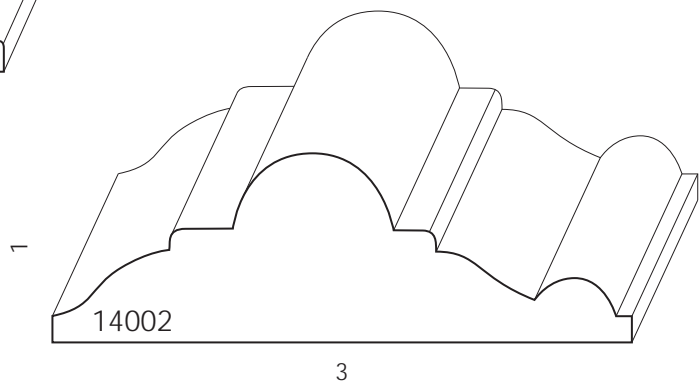
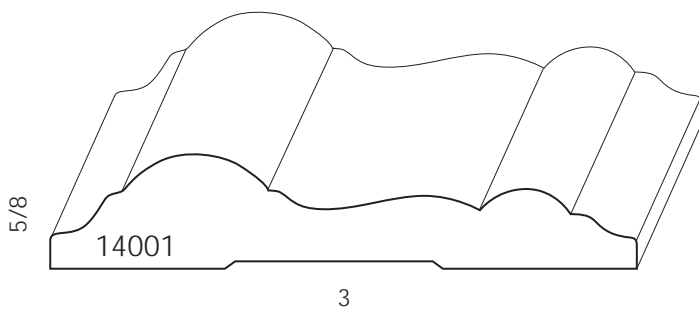



## Customized Details and Design Ideas

From showing the available styles and sizes of rosette and crown blocks, to creating 3-D illustrations for a beam or wainscoting, this section is intended to help you master the details of your design.

## Rosette and Plinth Blocks

We inventory the Rosette sizes and styles shown in Poplar, Red Oak, and Maple. We can also create a custom design of your choosing. Plinth blocks are also inventoried in matching widths and thicknesses.

Style	Width	Thickness
1	4 3/4	1 1/16
	5 3/4	1 1/16
2	3 3/4	1 1/16
	4	1 1/16
3	2 3/4	15/16

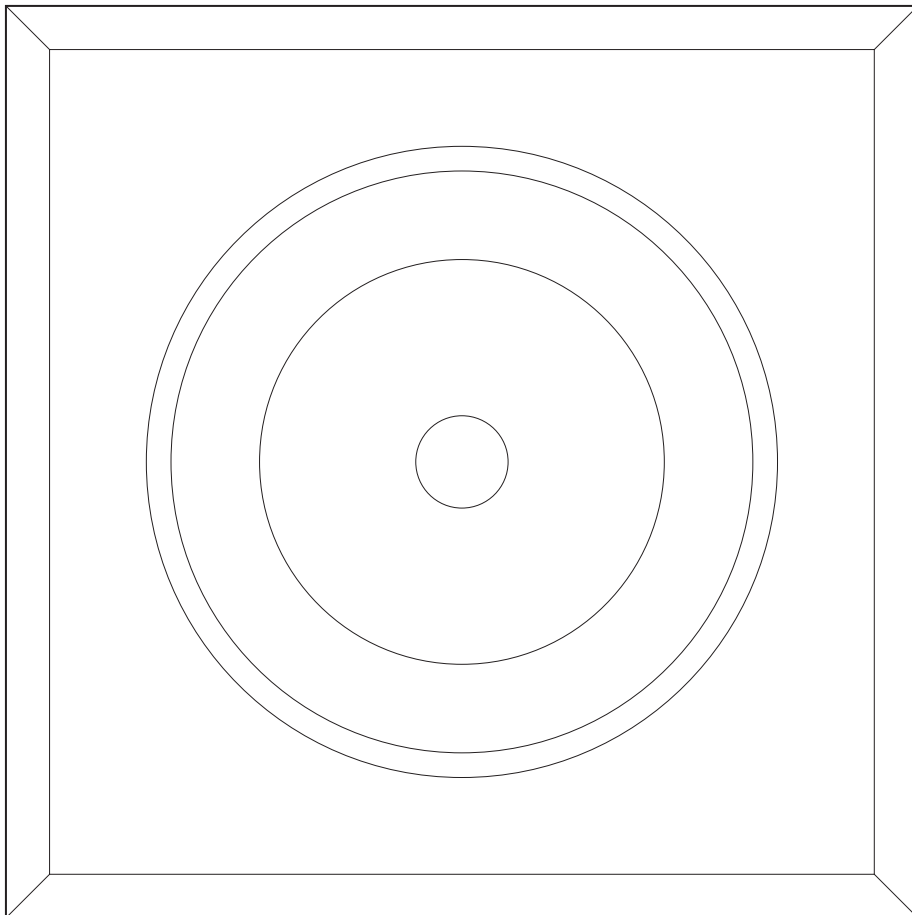

Style 1 Rosette

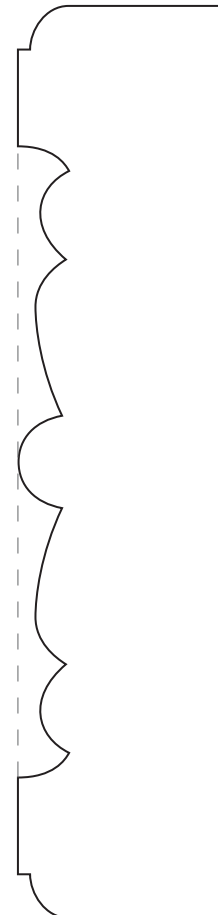

1 1/16

4 3/4

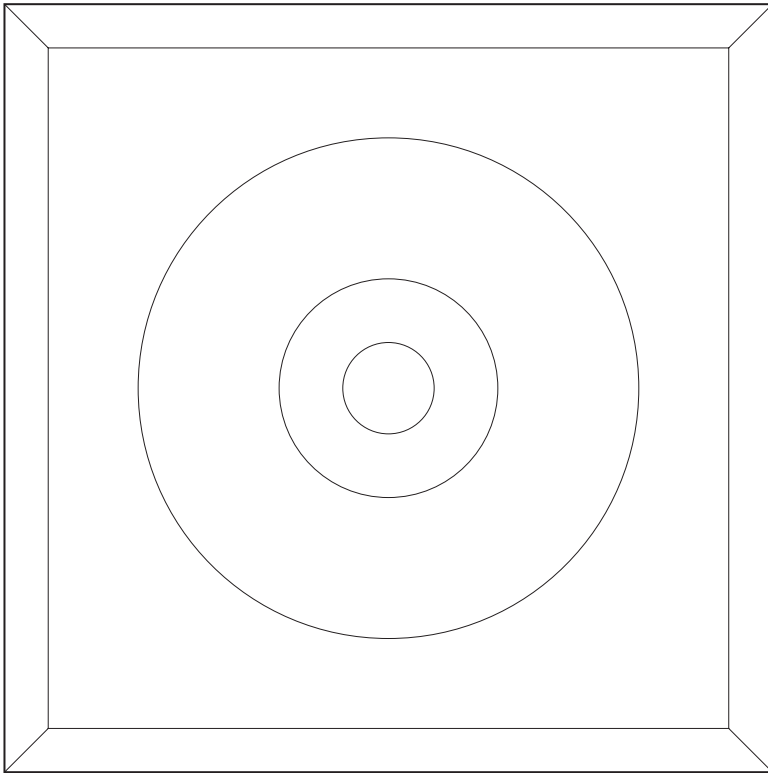

Style 2 Rosette

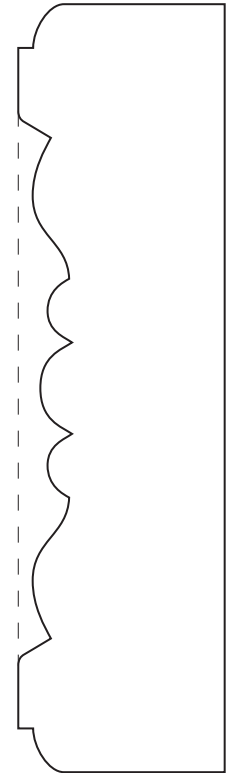

1 1/16

4

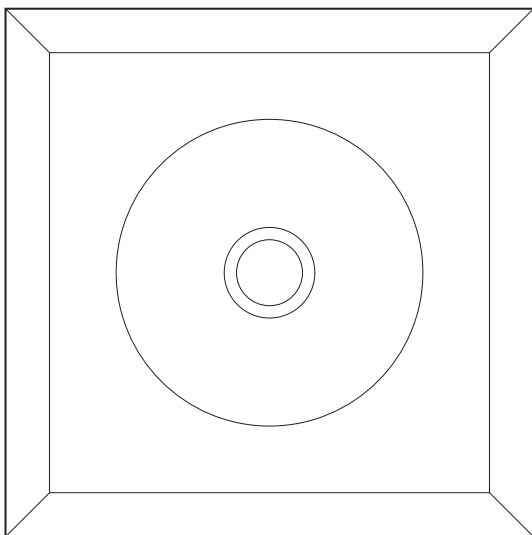

Style 3 Rosette

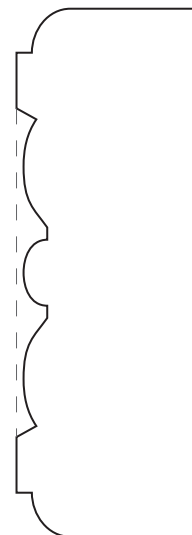

15/16

2 3/4

## Base and Crown Corner Blocks

Base and crown corner blocks are available in any size to match your base and crown styles.

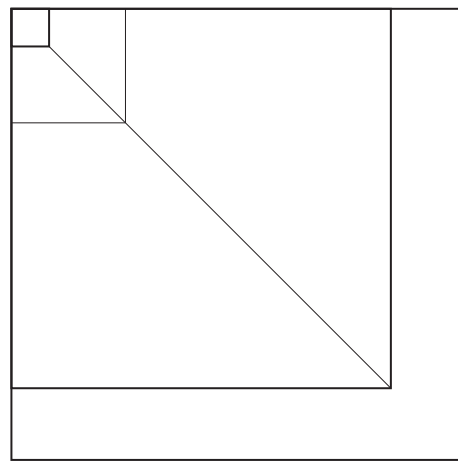
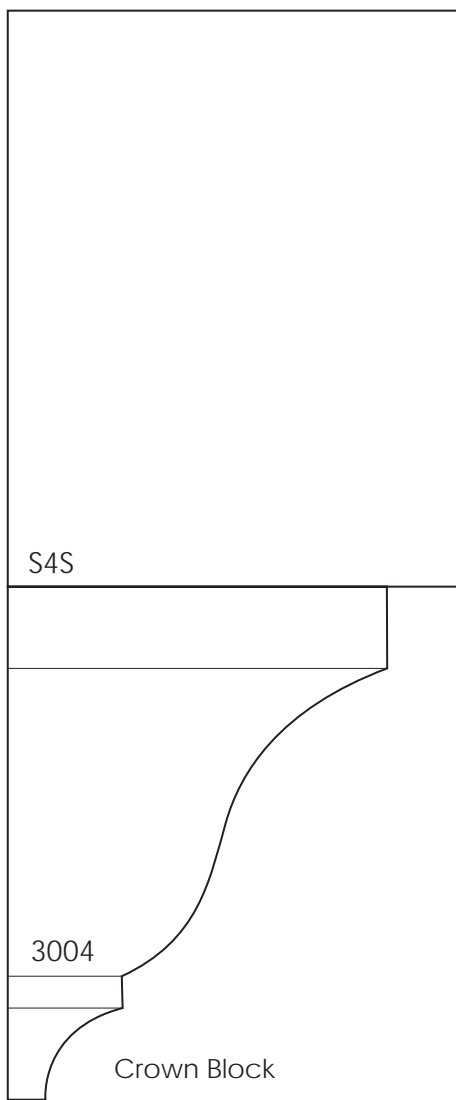

Inside-corner Crown Block  
[bottom-view]

Mid-run and outside-corner crown blocks are also available.

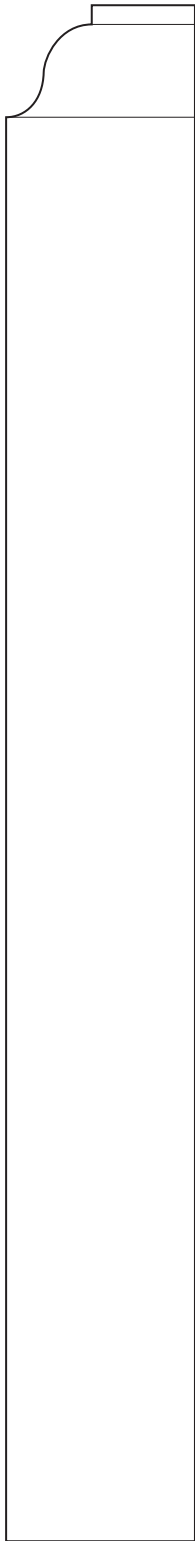

Base Block

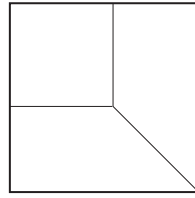

Inside-corner Base Block  
[top-view]

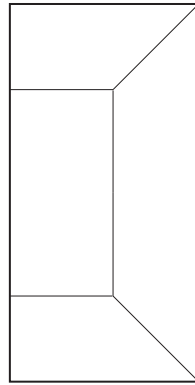

Mid-run Base Block  
[top-view]

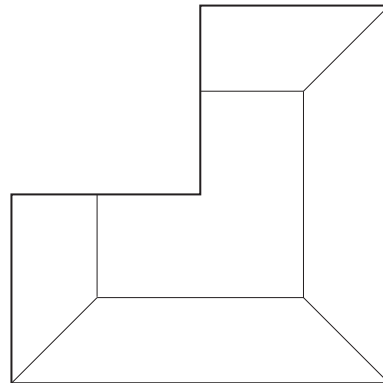

Outside-corner Base Block  
[top-view]

## Mantles

Solid wood mantles and mantle legs can be created from our moulding styles to complete a custom design. Below is an example of a mantle using two popular moulding styles and S4S lumber.

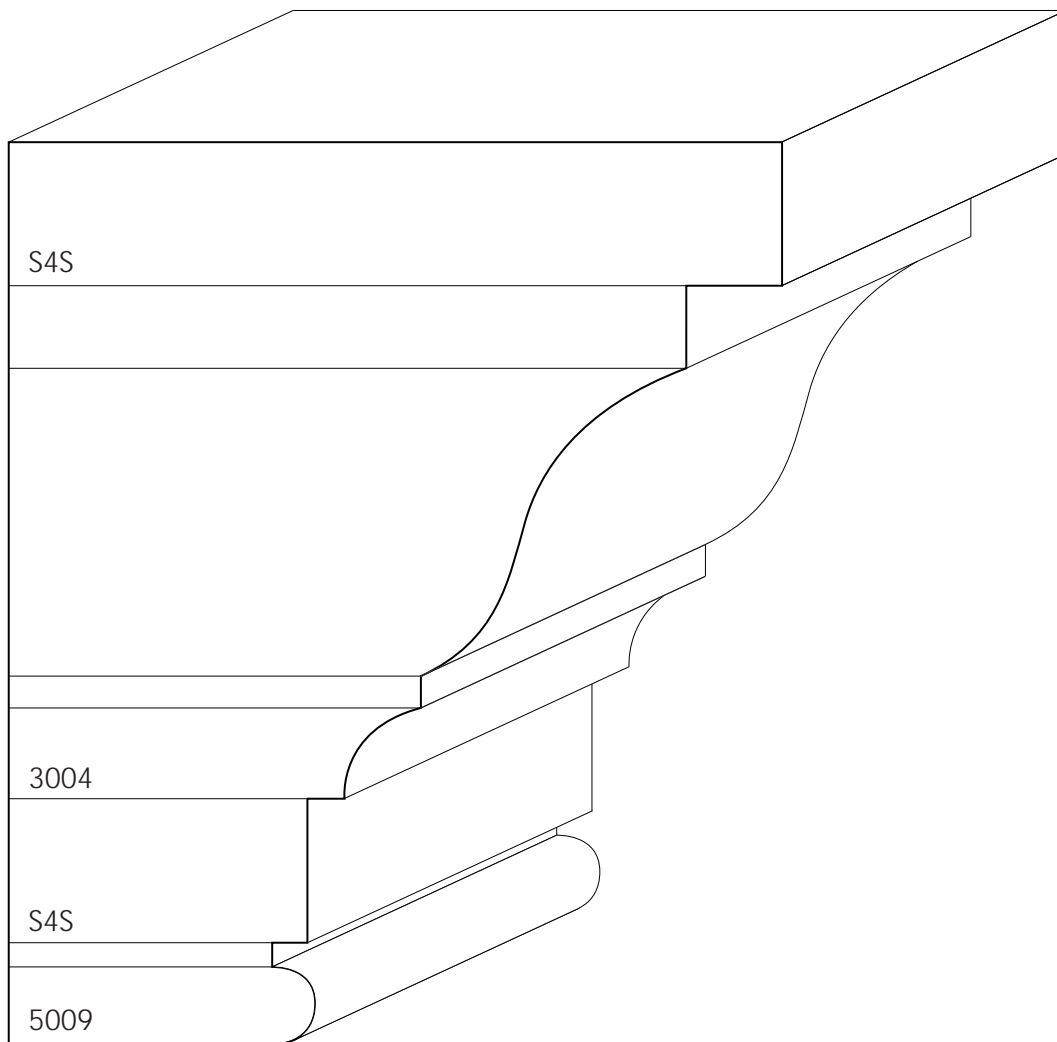

## Dentil Mould

Shown below are the two styles of dentil mold that we inventory in Poplar and Red Oak. Custom sizes are available.

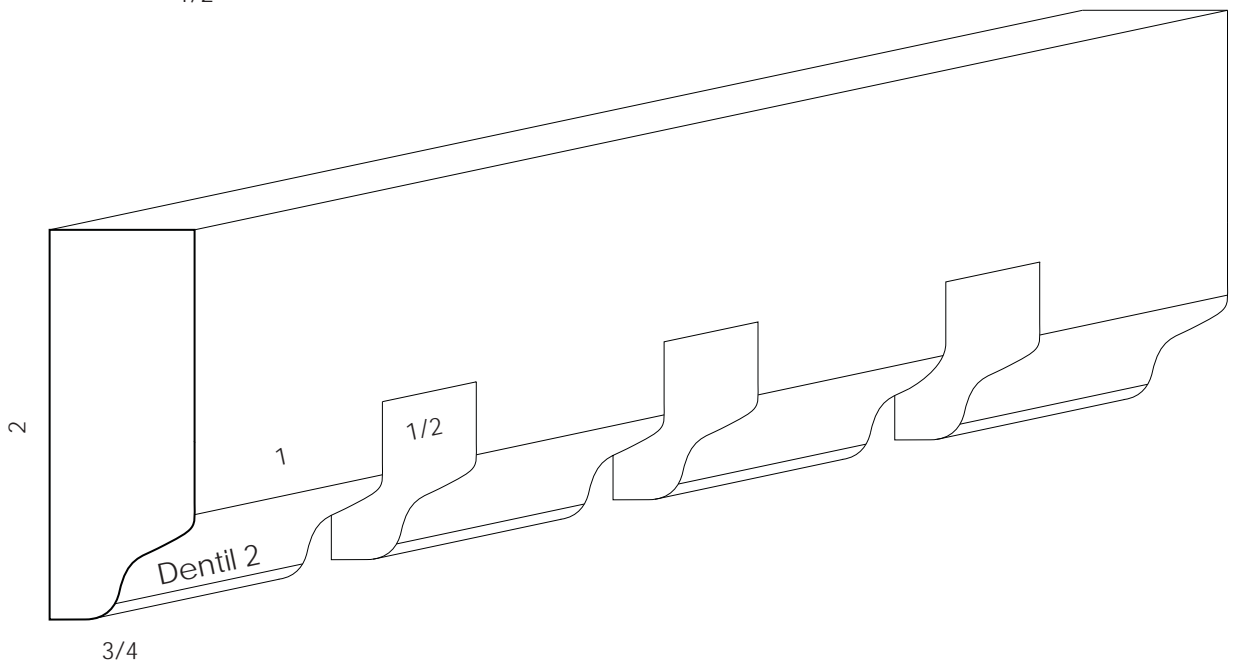
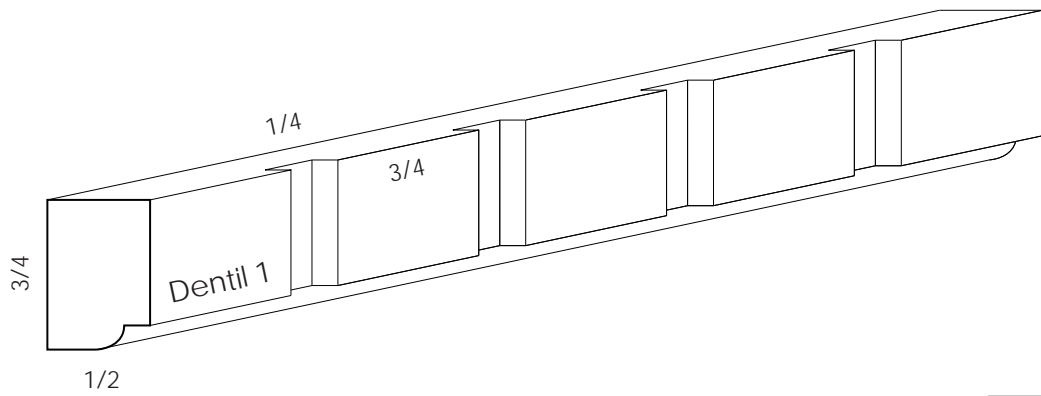

## Crown Build-up

Crown and baseboard can be combined to create a more dramatic and custom look.

1. 2023 Baseboard, 3023 Crown
2. 2045 Baseboard, 3035 Crown
3. 1043 Casing, 3046 Crown
4. 2043 Baseboard, 3071 Crown
5. 2009 Baseboard, 3035 Crown
6. 2010 Baseboard, 3005 Crown
7. 2005 Baseboard, 3005 Crown, 4005 Chair Rail
8. 2072 Baseboard, 3035 Crown
9. 5023 Small Mold, 3053 Crown
10. 1126 Casing, 8039 Mold, 3010 Crown
11. 2054 Baseboard, 3073 Crown
12. 1x2 S4S, 2005 Baseboard, 3001, 3005 Crown
13. 7014 Backband, 2069 Baseboard, 3034 Crown, S4S
14. 2078 Baseboard, 3049 Crown
15. 2029 Baseboard, 3034 Crown
16. E1E S4S, 3080 Crown
17. 2054 Baseboard, 3055 Crown
18. 2075 Baseboard, 3057 Crown
19. 2045 Baseboard, 3056 Crown

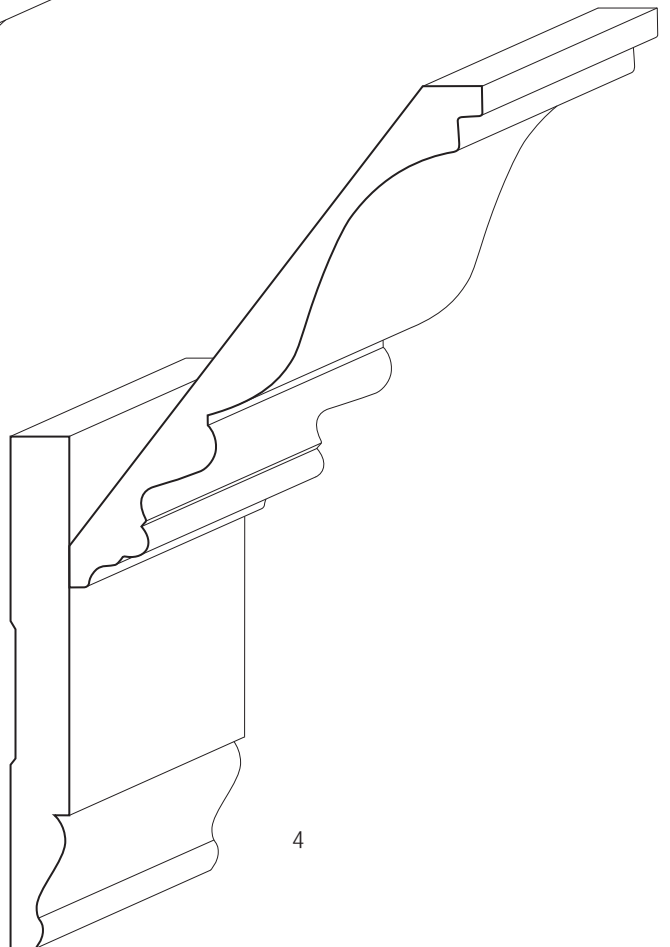
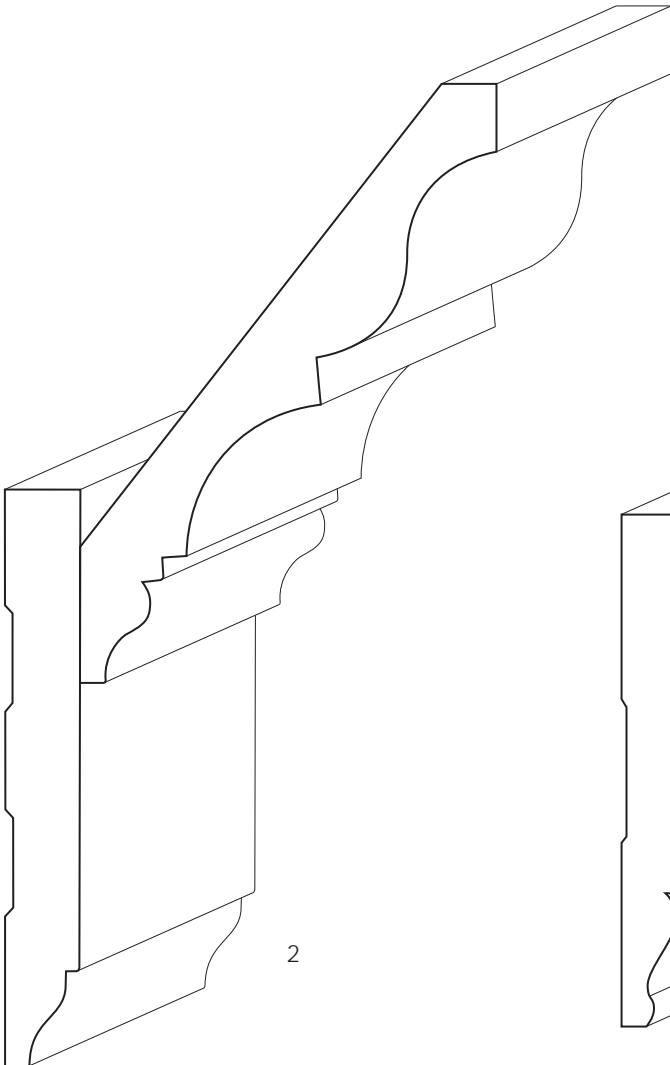
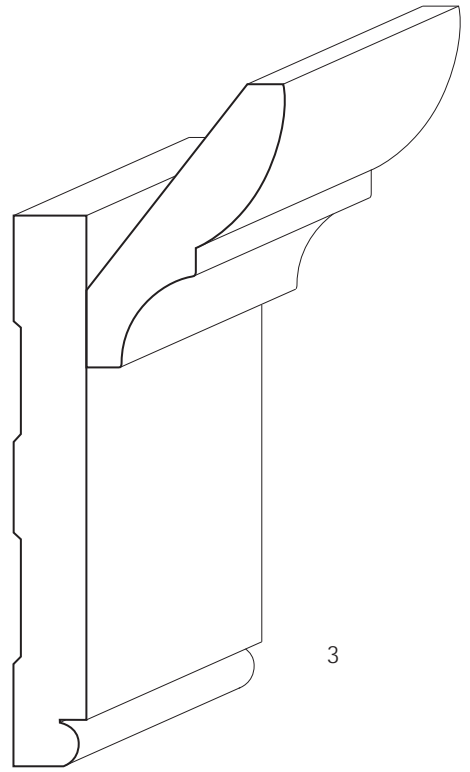
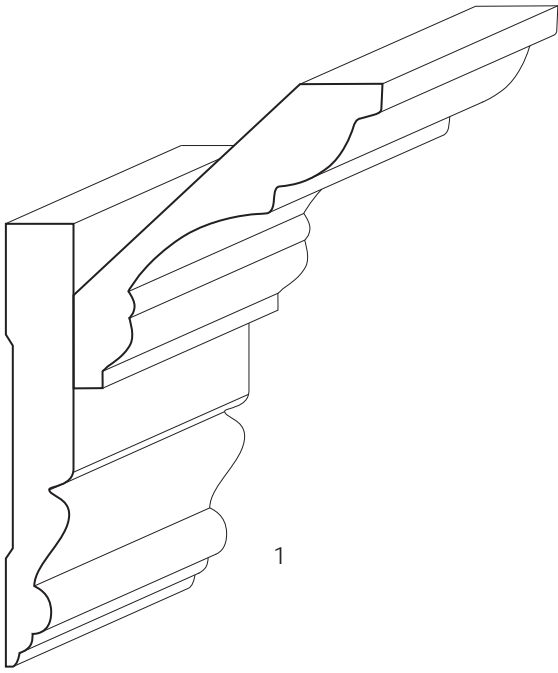

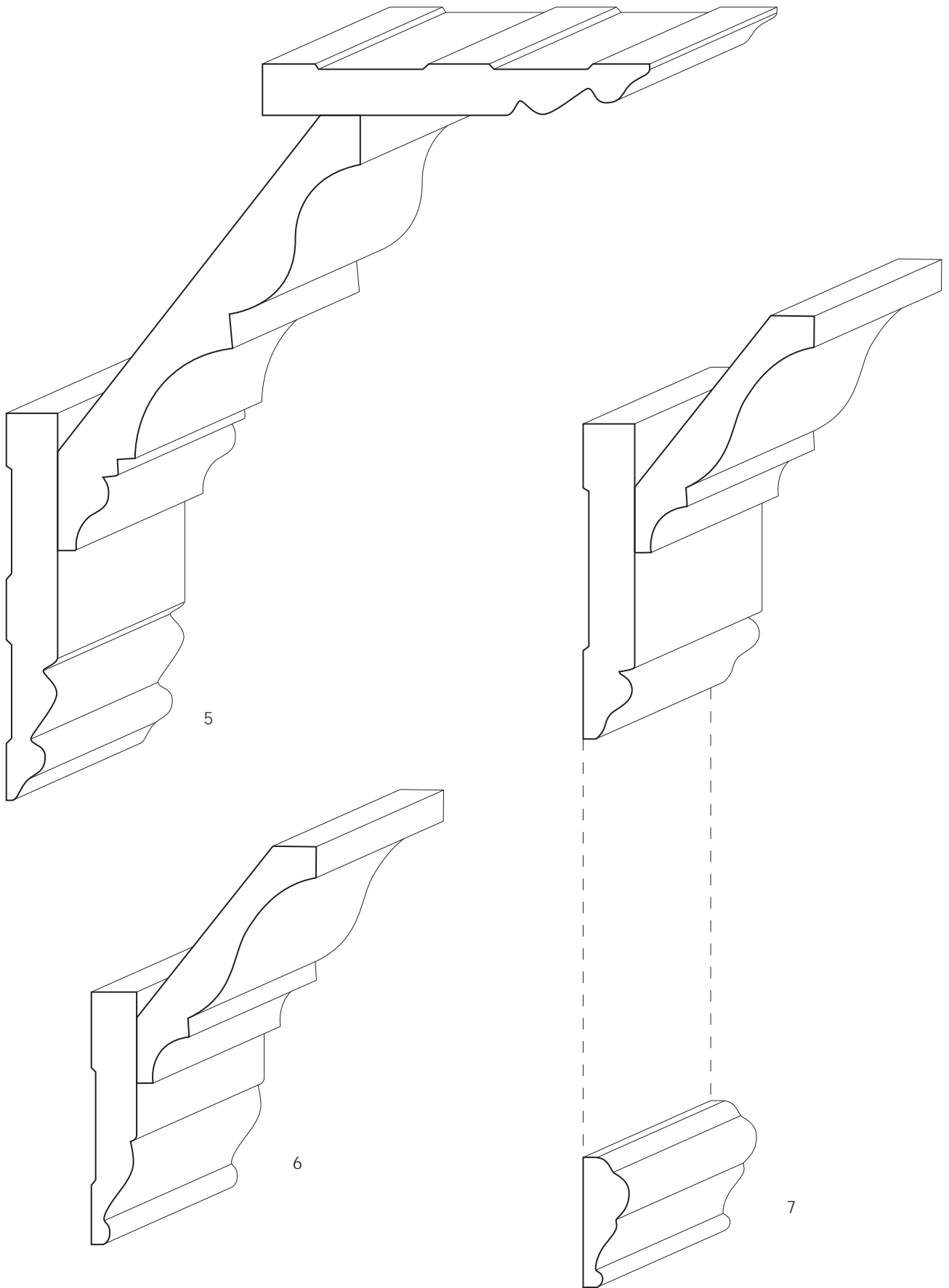

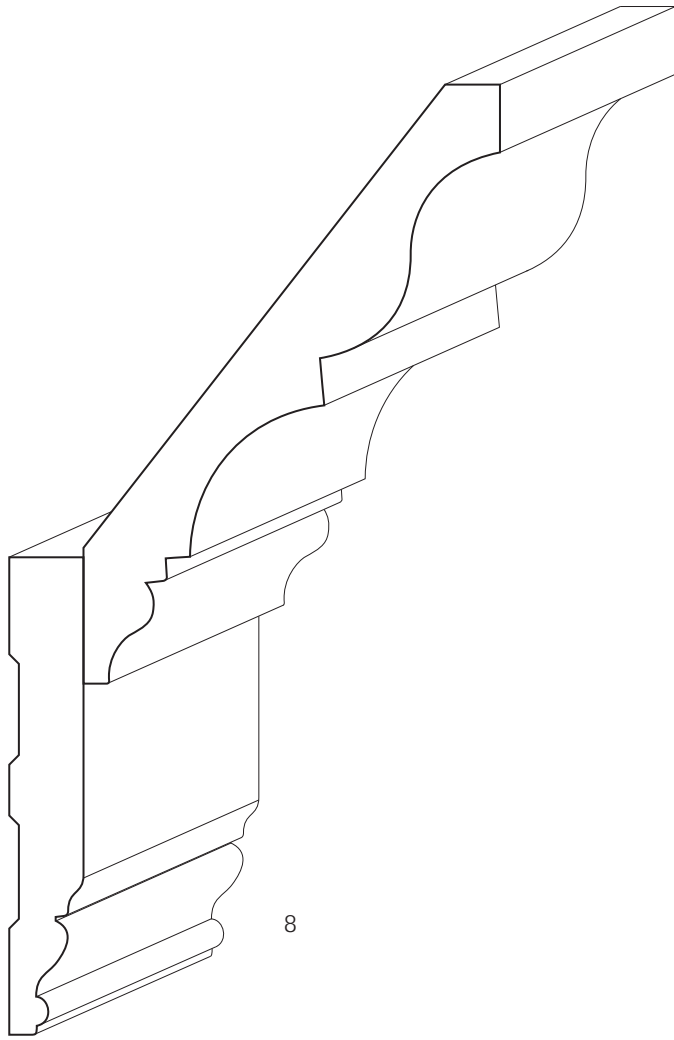

8

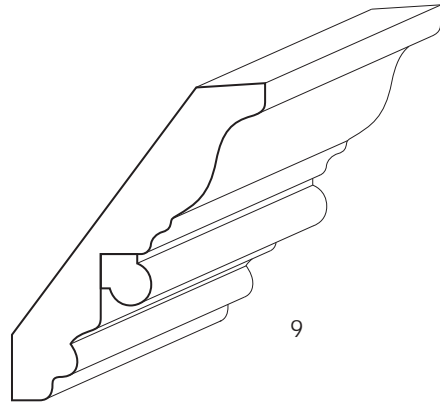

9

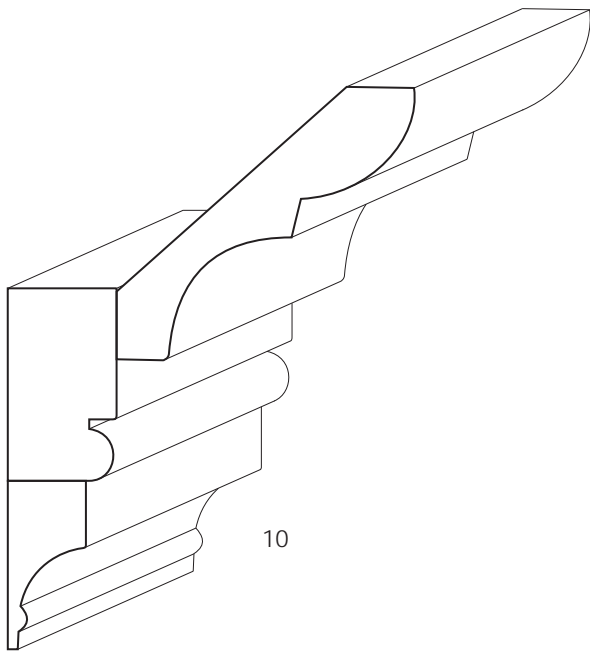

10

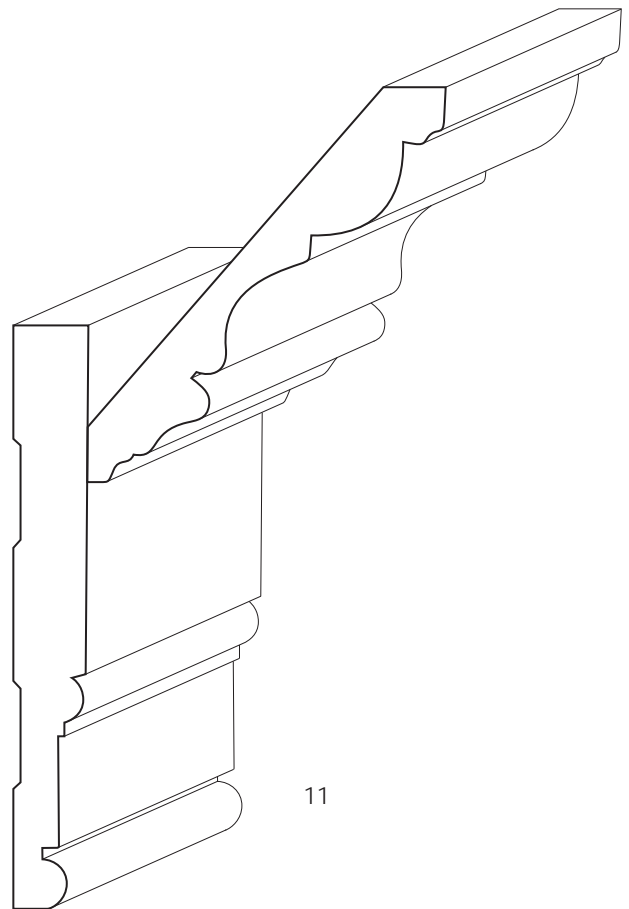

11

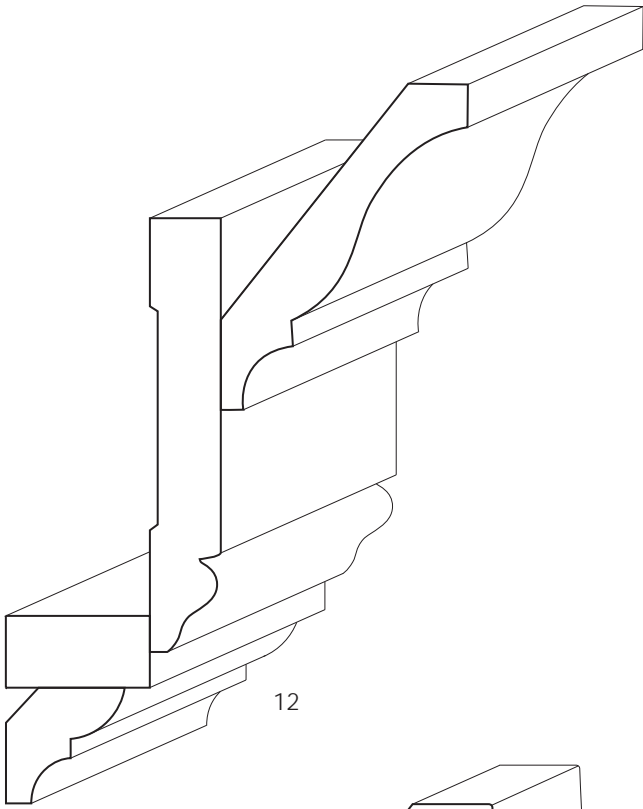

12

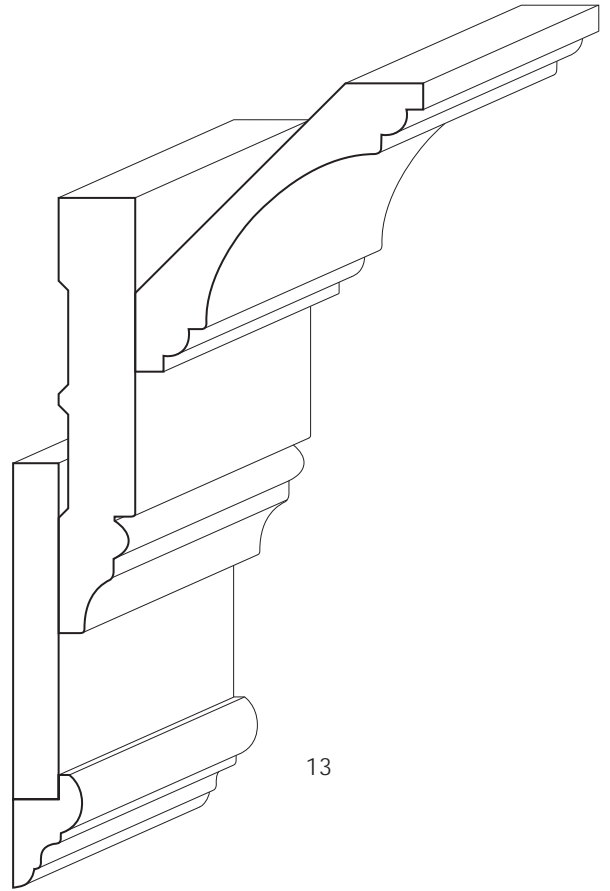

13

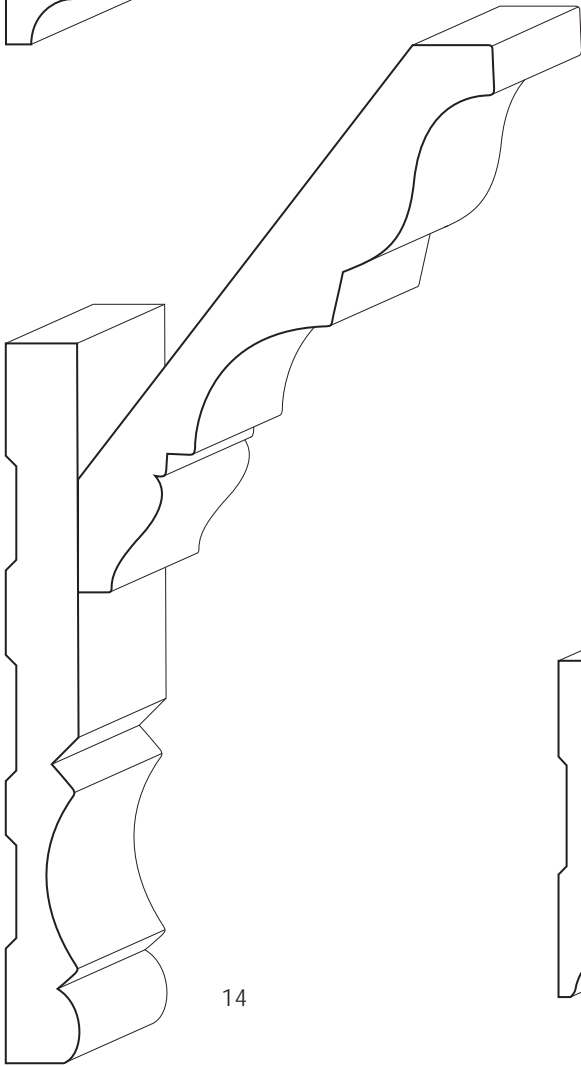

14

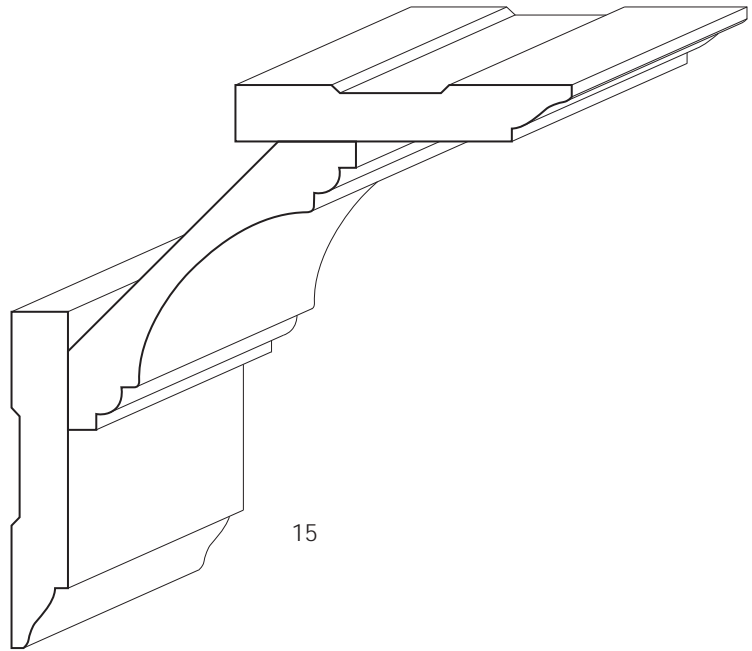

15

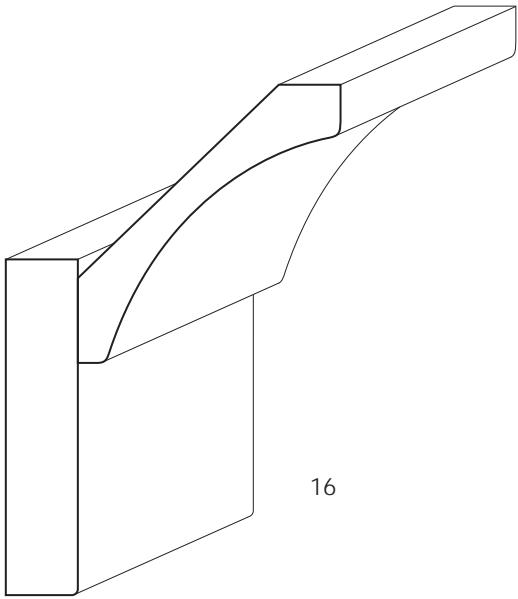

16

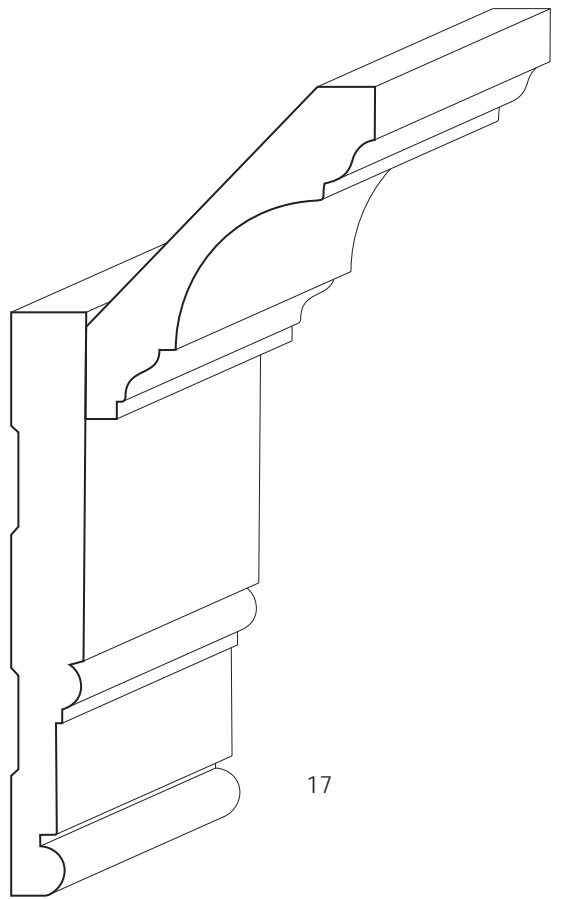

17

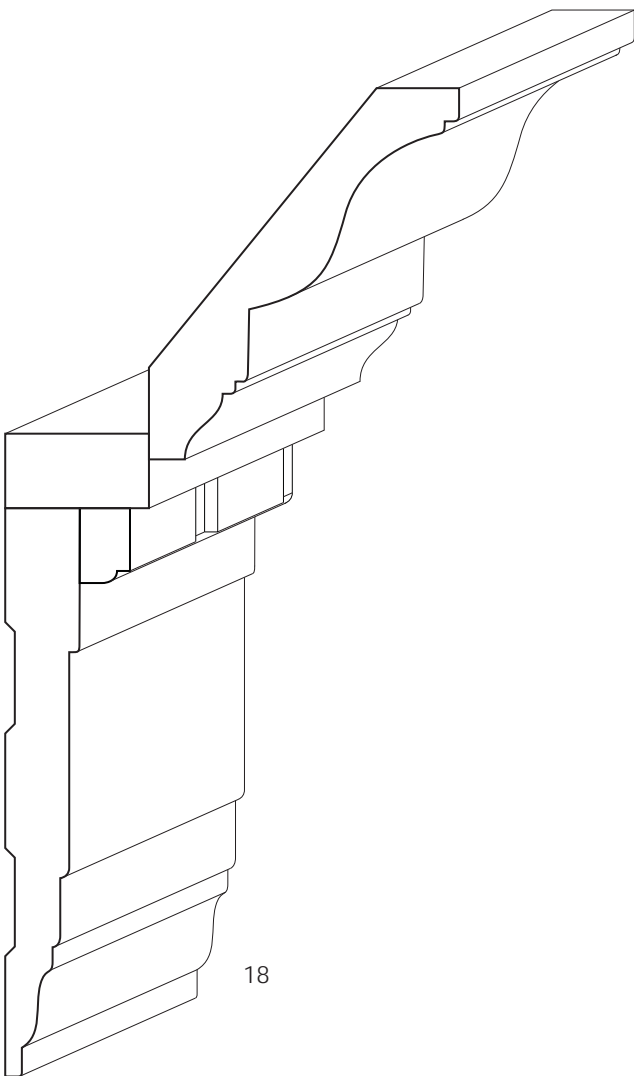

18

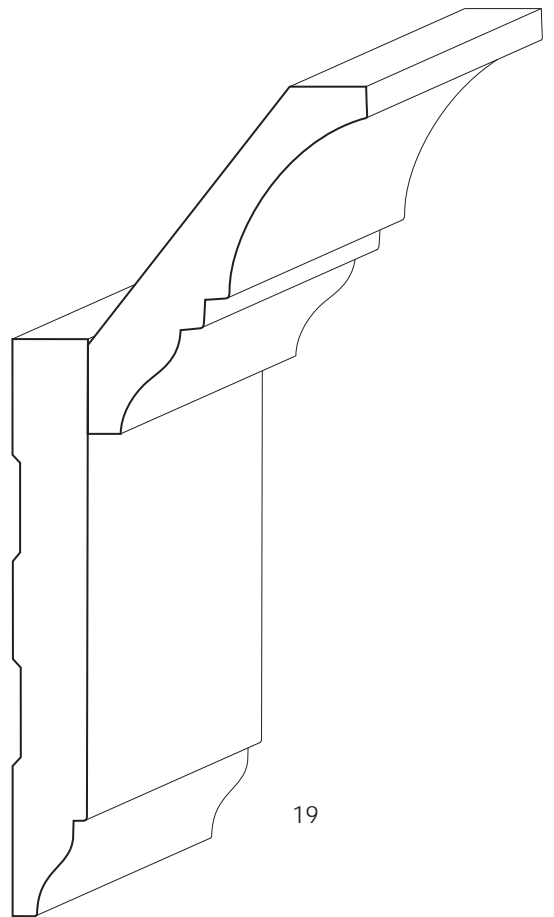

19

## Beams

Beams, when used on ceilings or walls, add depth, dimension, and character to any room.

1. 1 x 6 [sides], 1 x 4 [bottom]
2. 3004 [top corner], 1 x 6 [top sides], 3001 [middle side]  
1 x 4 [bottom side and bottom], 5007 [bottom corner]
3. 8079 [top corners], 5020 [bottom corners], 1 x 8 [sides],  
1 x 6 [bottom]
4. 3001 [top corners], 5007 [bottom corners], 1 x 4 [sides],  
1 x 6 [bottom]
5. 3005 [top corners], 5007 [bottom corners], 1 x 6 [sides],  
1 x 6 [bottom]
6. 3005 [top corners], 1 x 8 [sides], 1 x 6 [bottom]

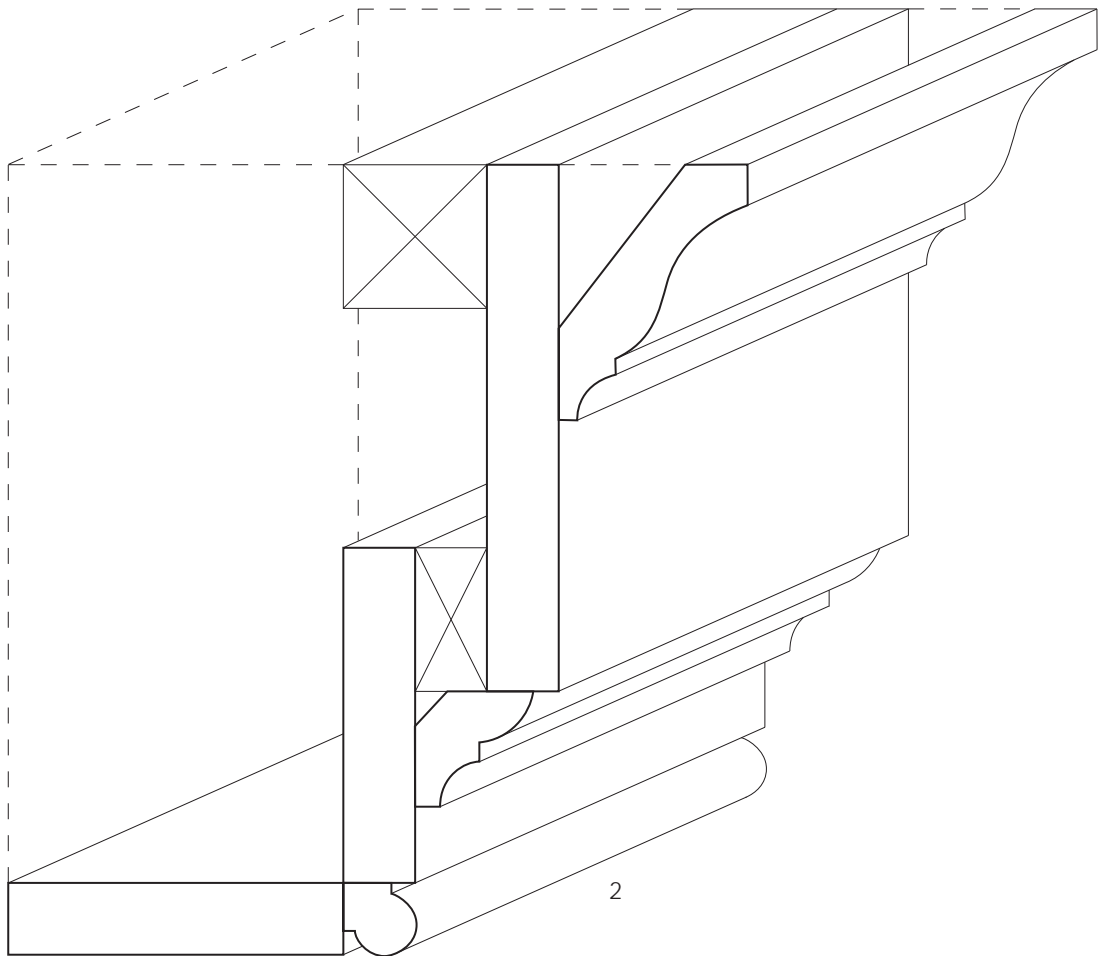
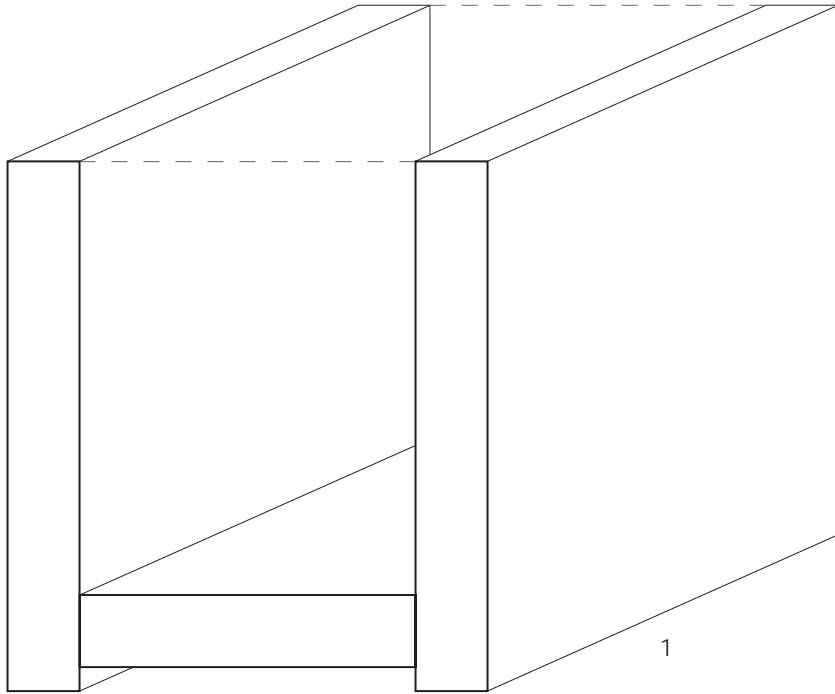

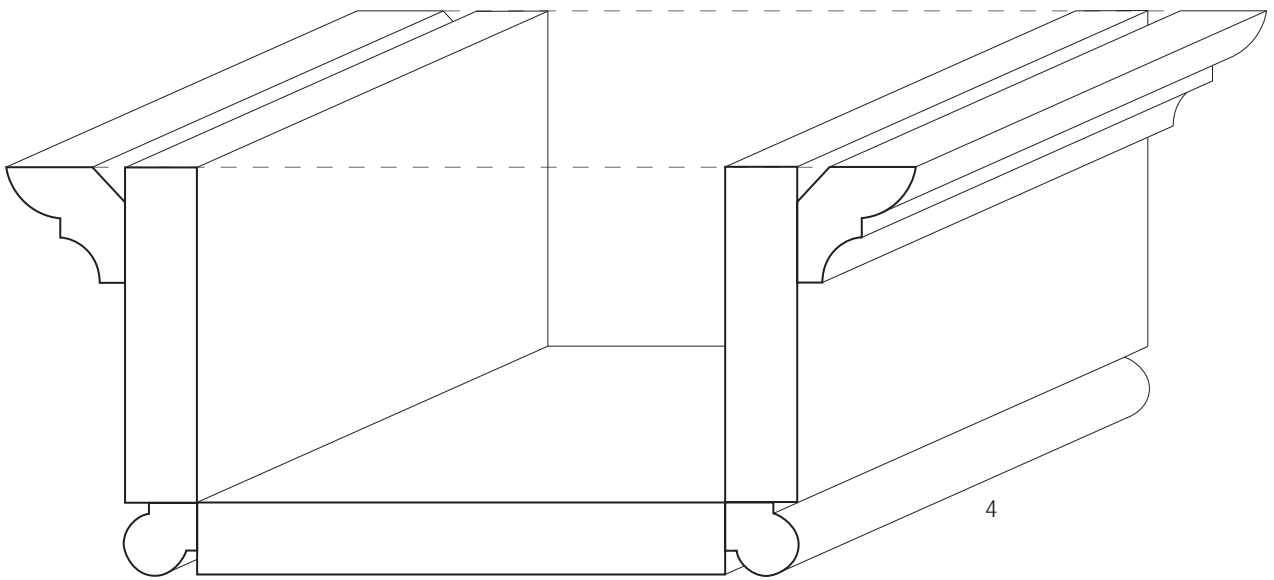
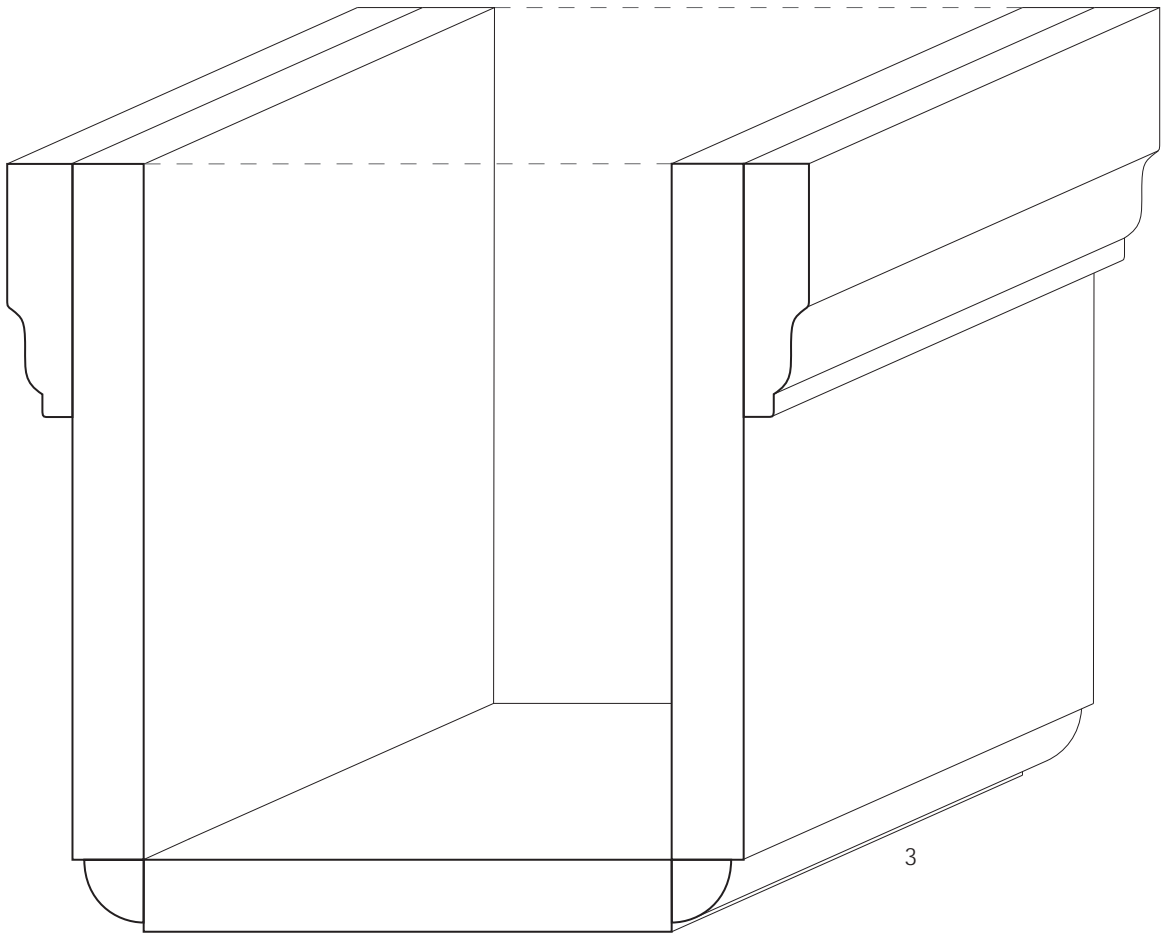

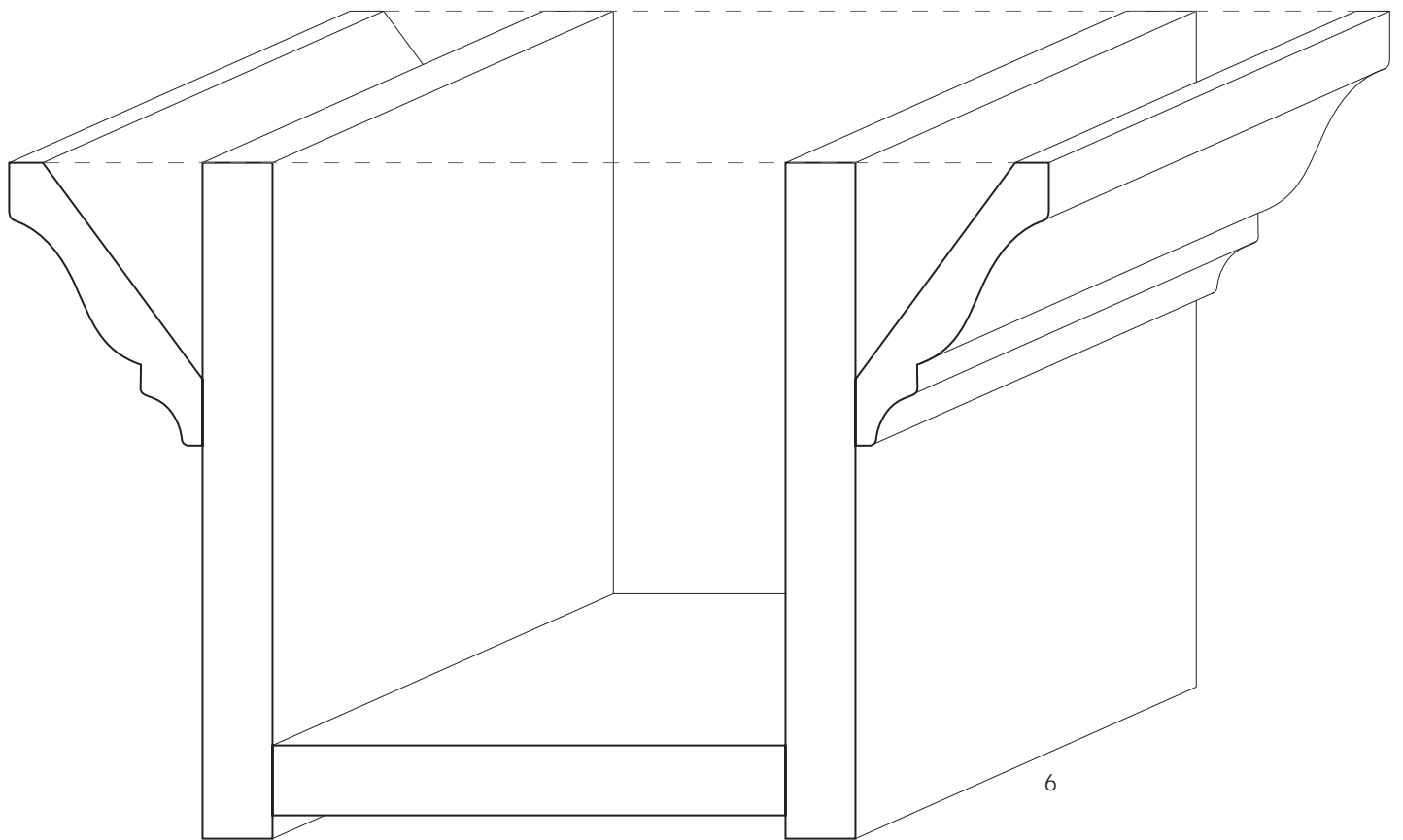
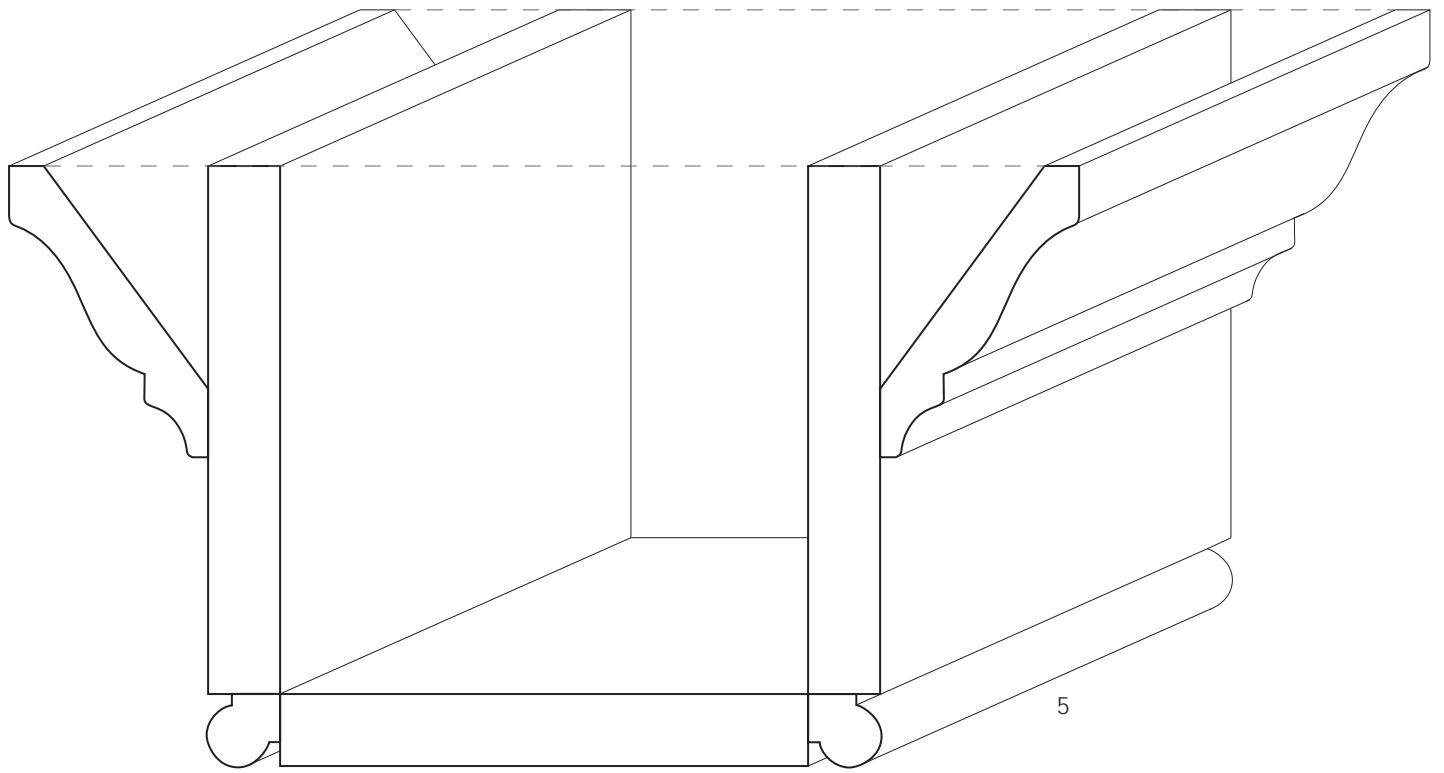

## Wainscoting / Wall Paneling

Wainscoting and wall paneling styles are extremely versatile, accomodating a variety of architectural styles and room configurations, and can be combined with short walls, pillars, and pilasters at room openings.

5203 Modified

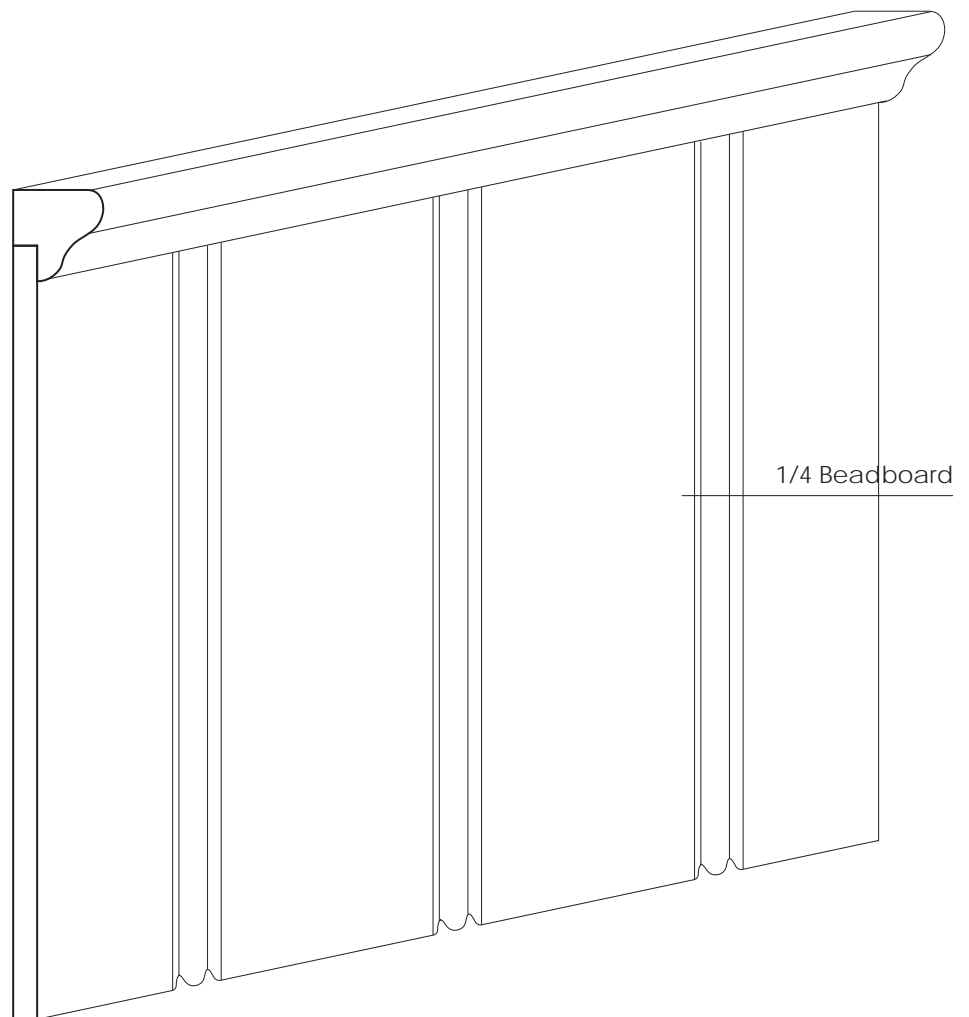

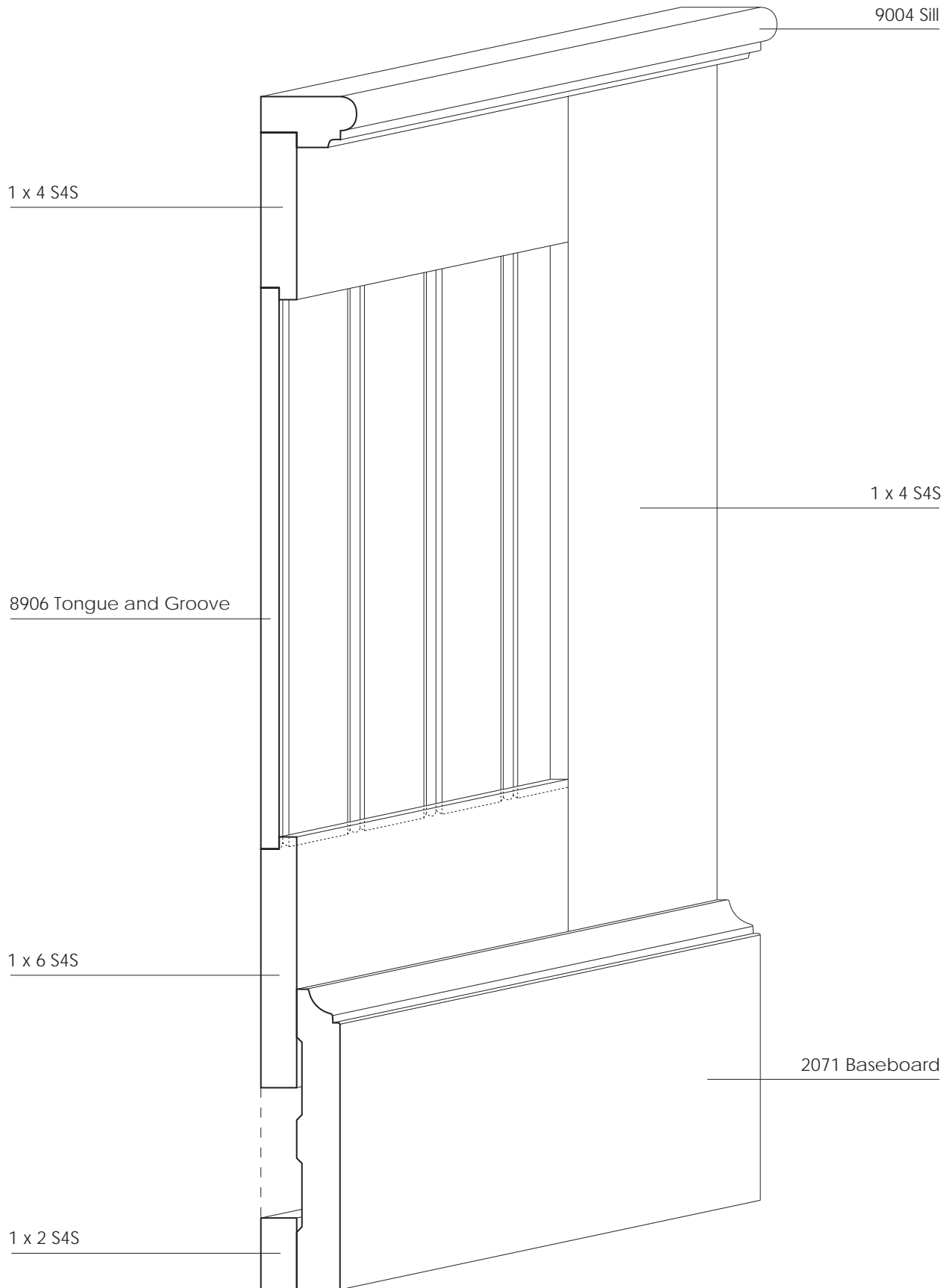

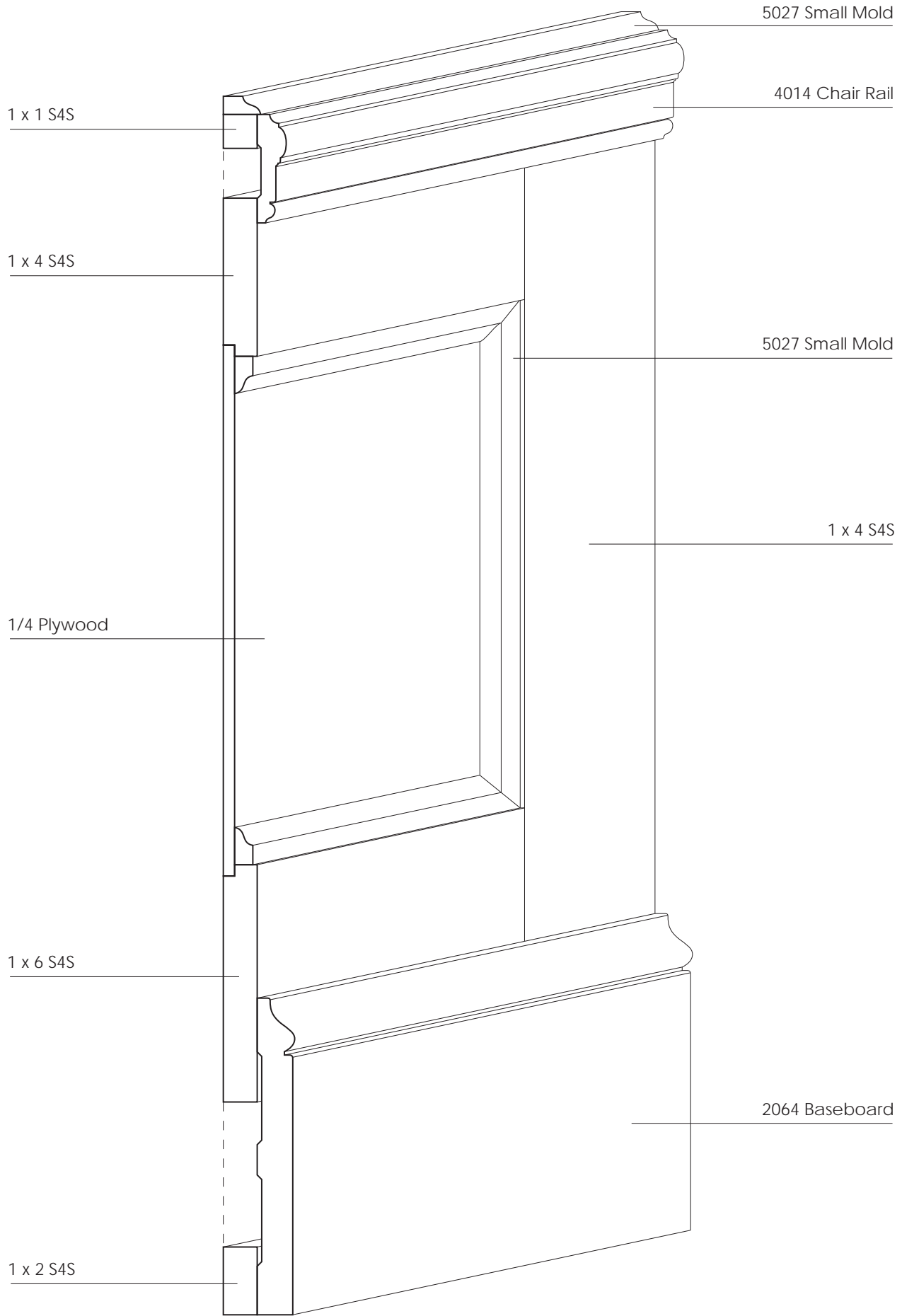

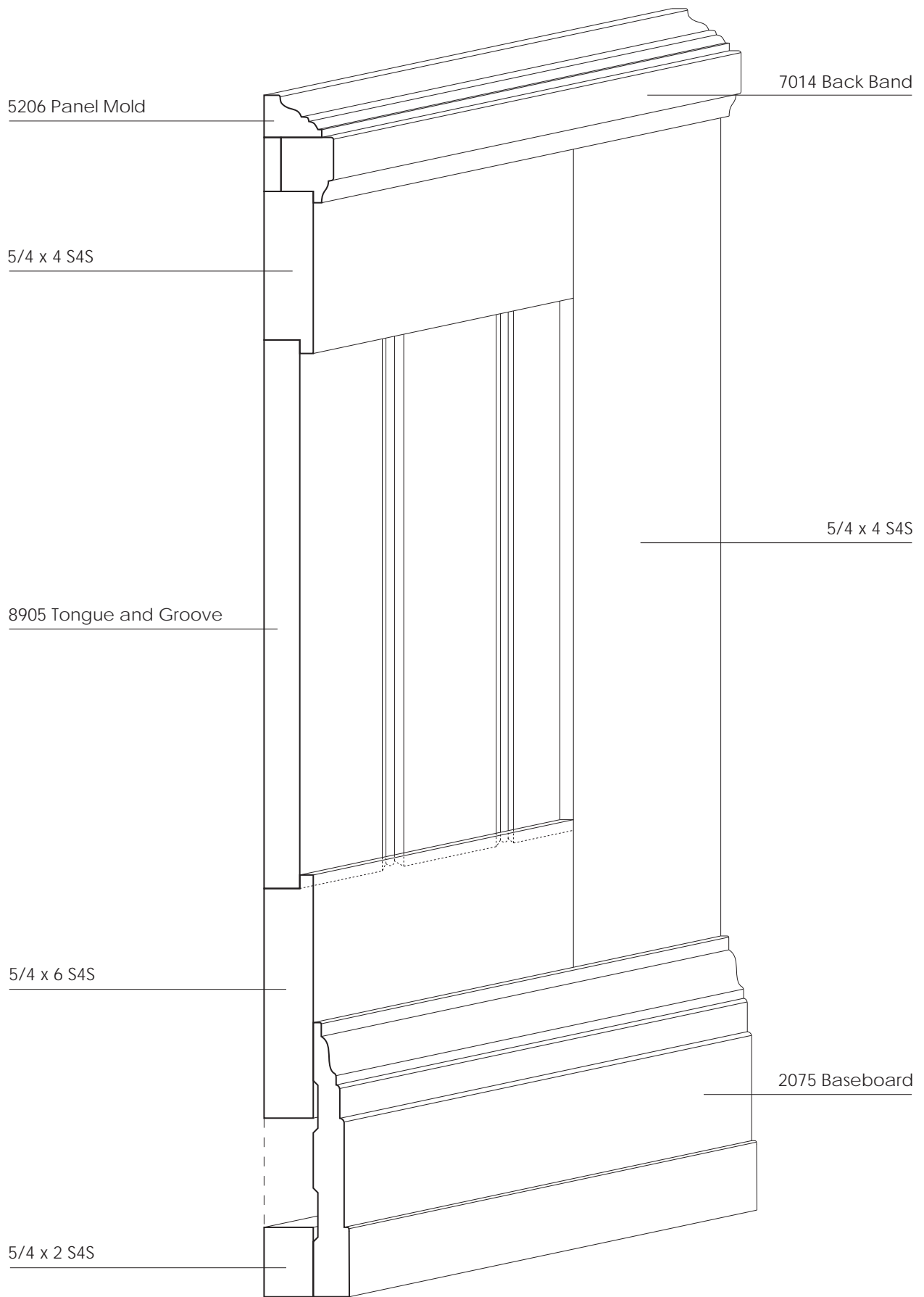

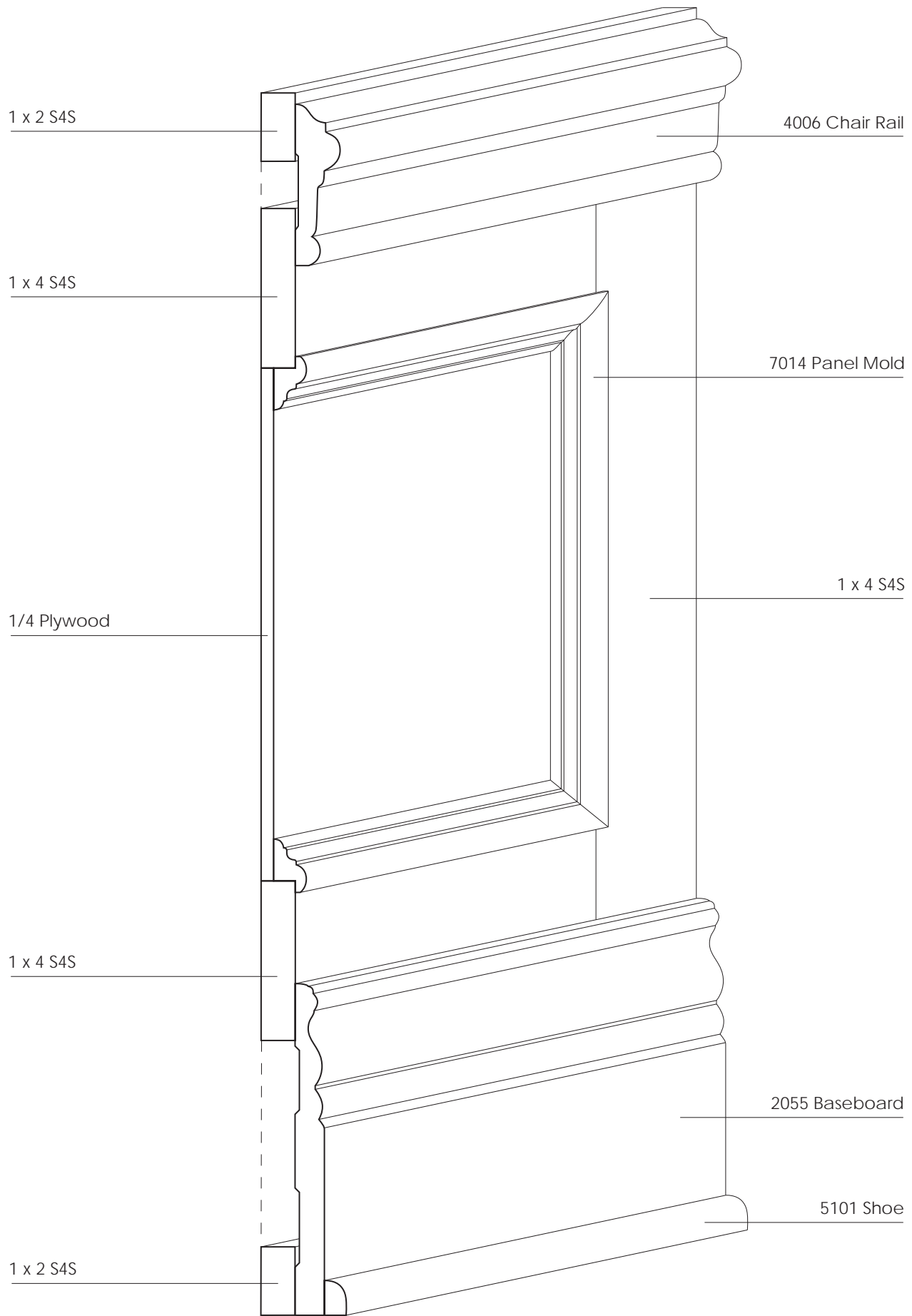

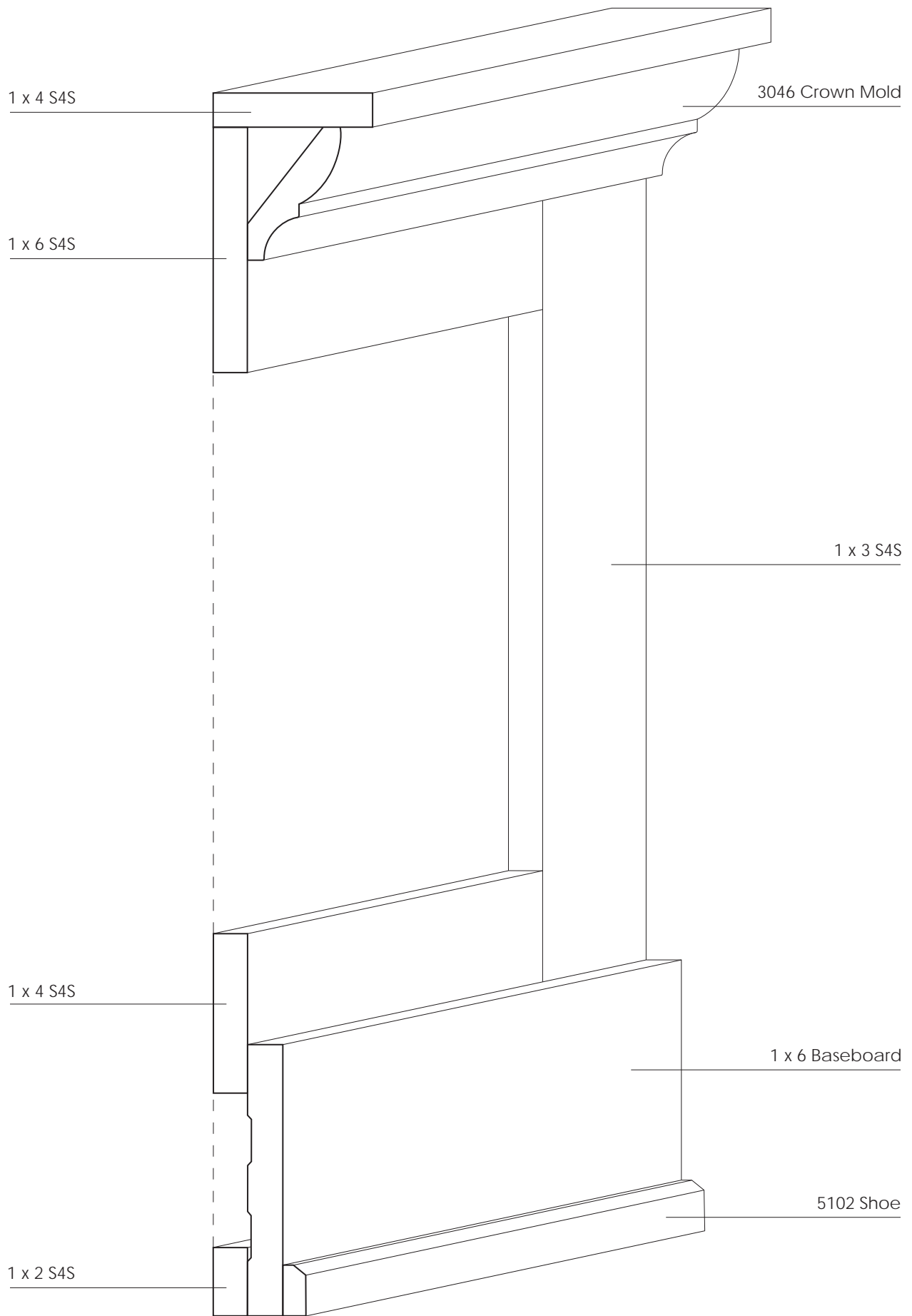

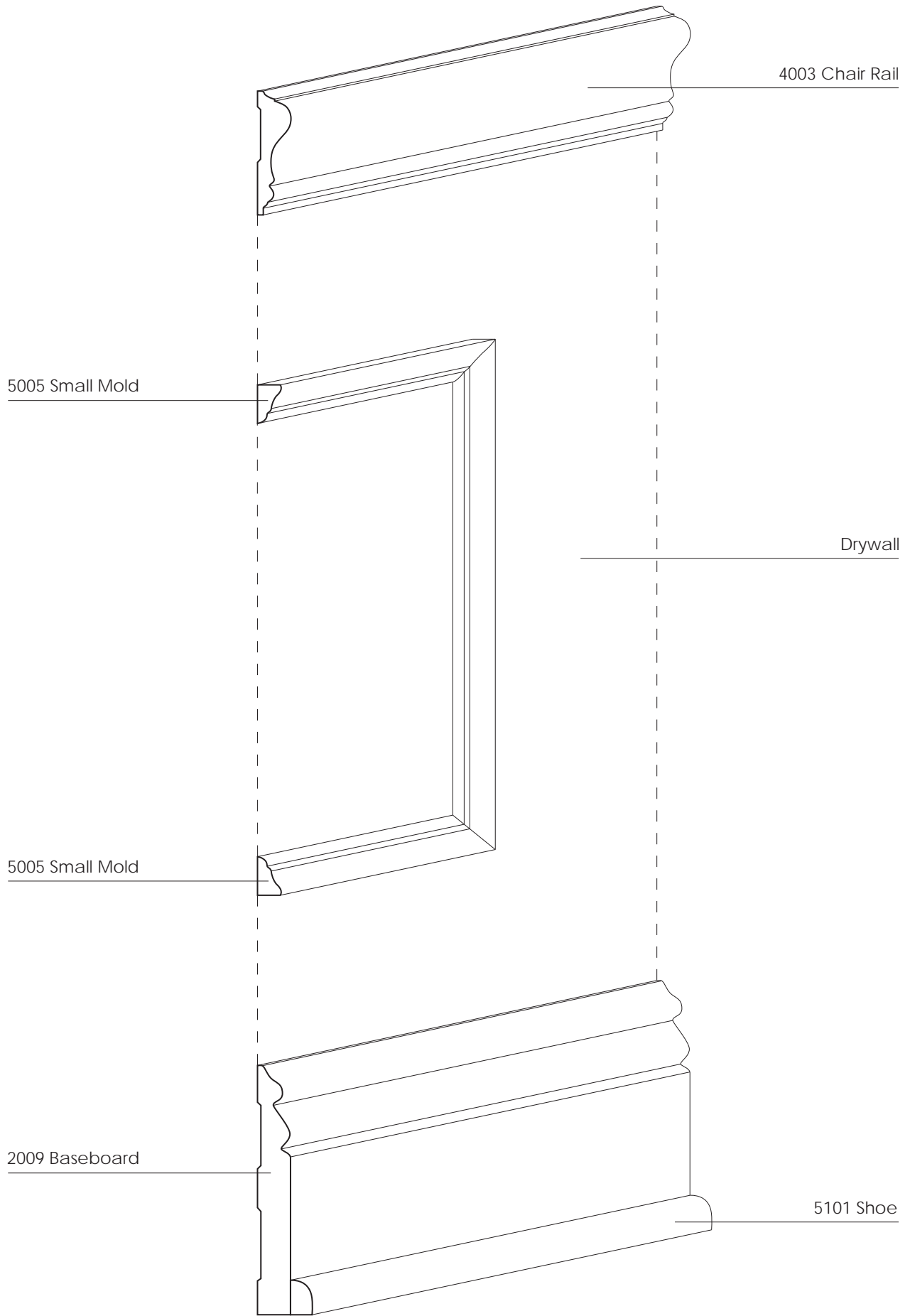

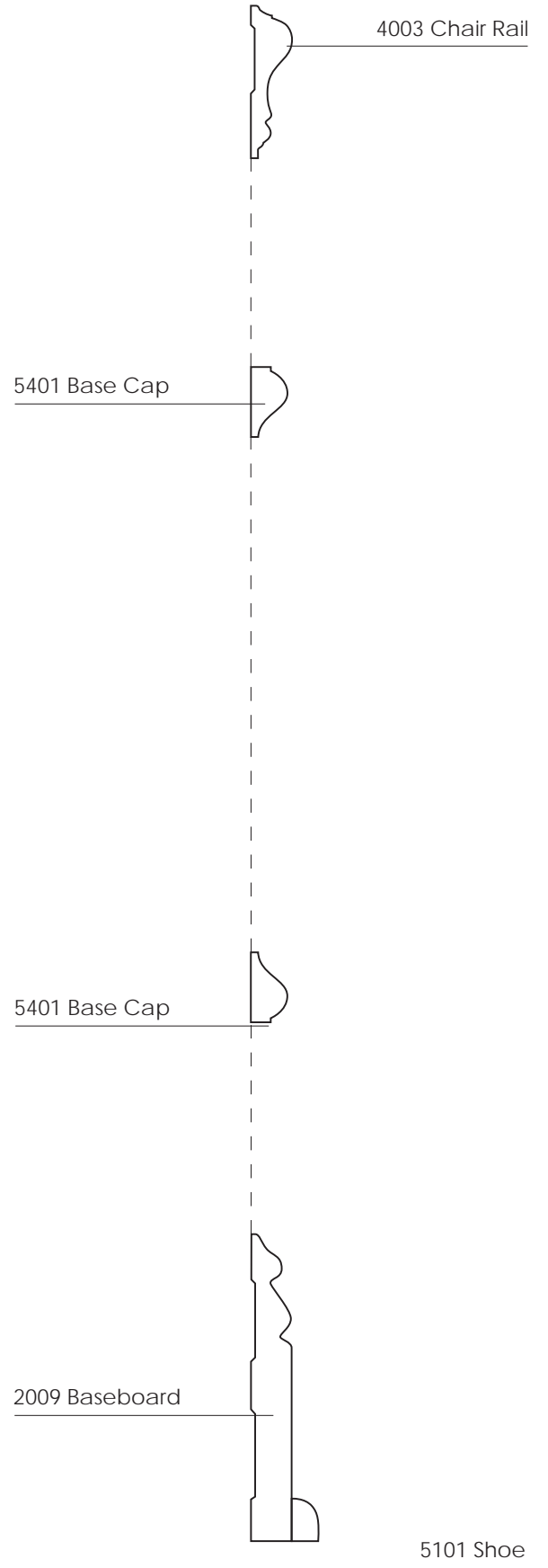
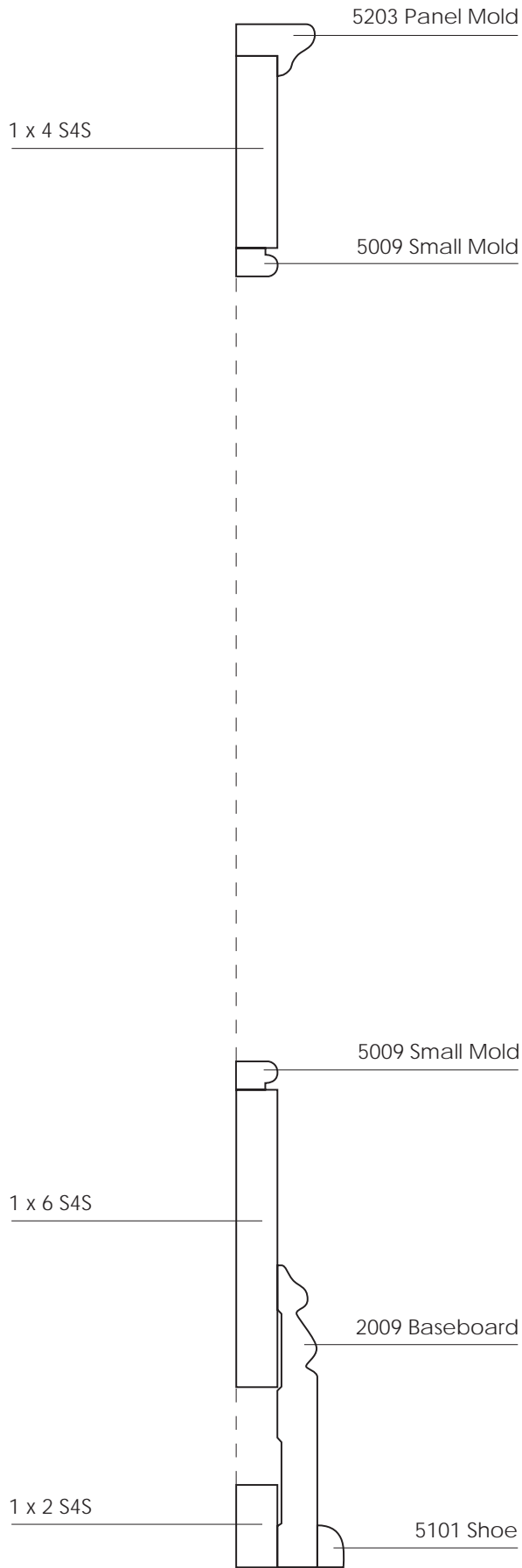

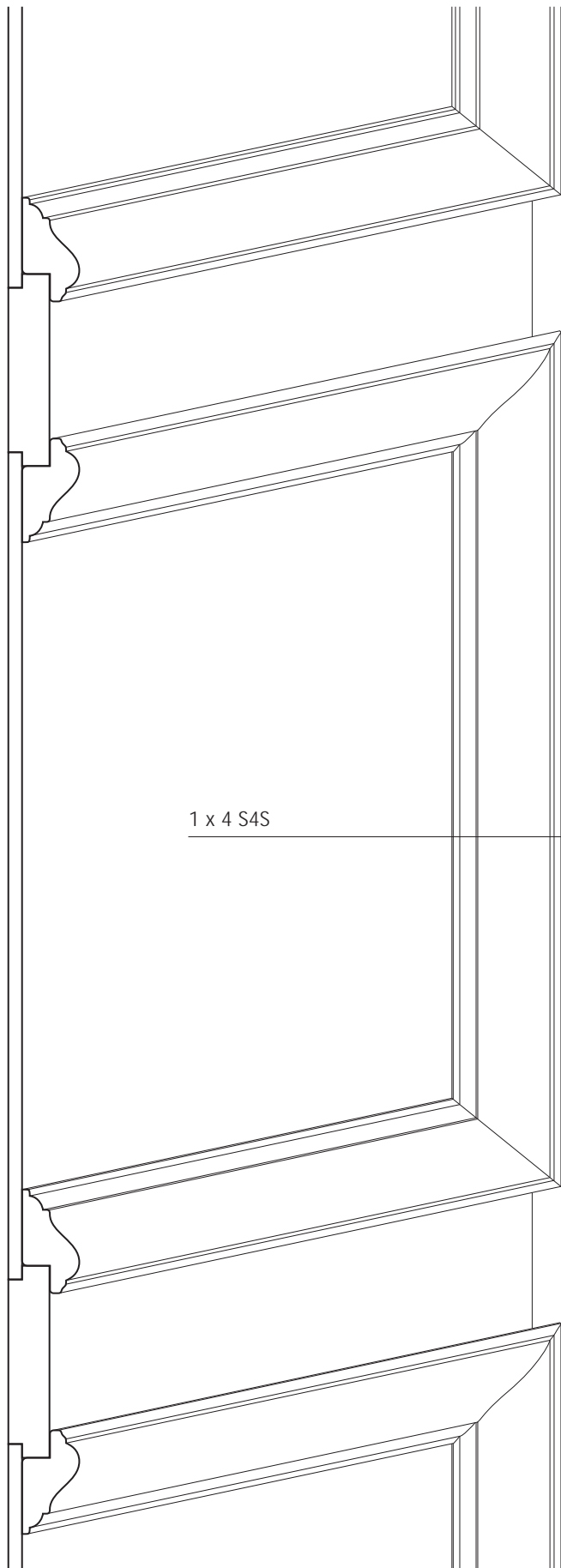

1 x 4 S4S

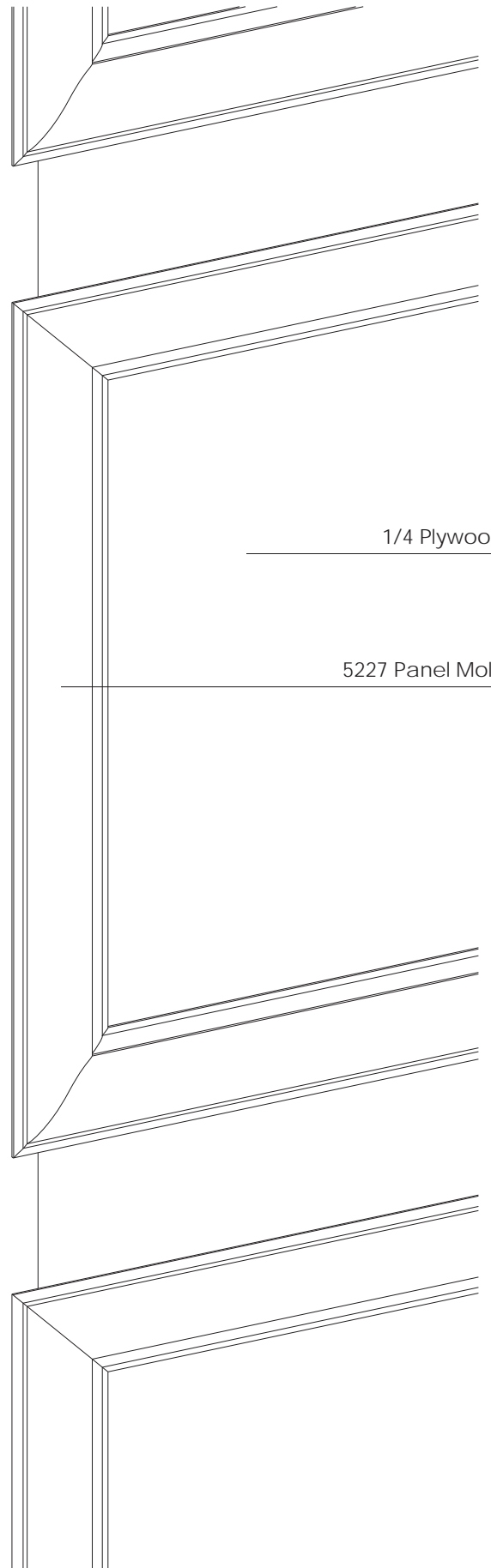

1/4 Plywood

5227 Panel Mold

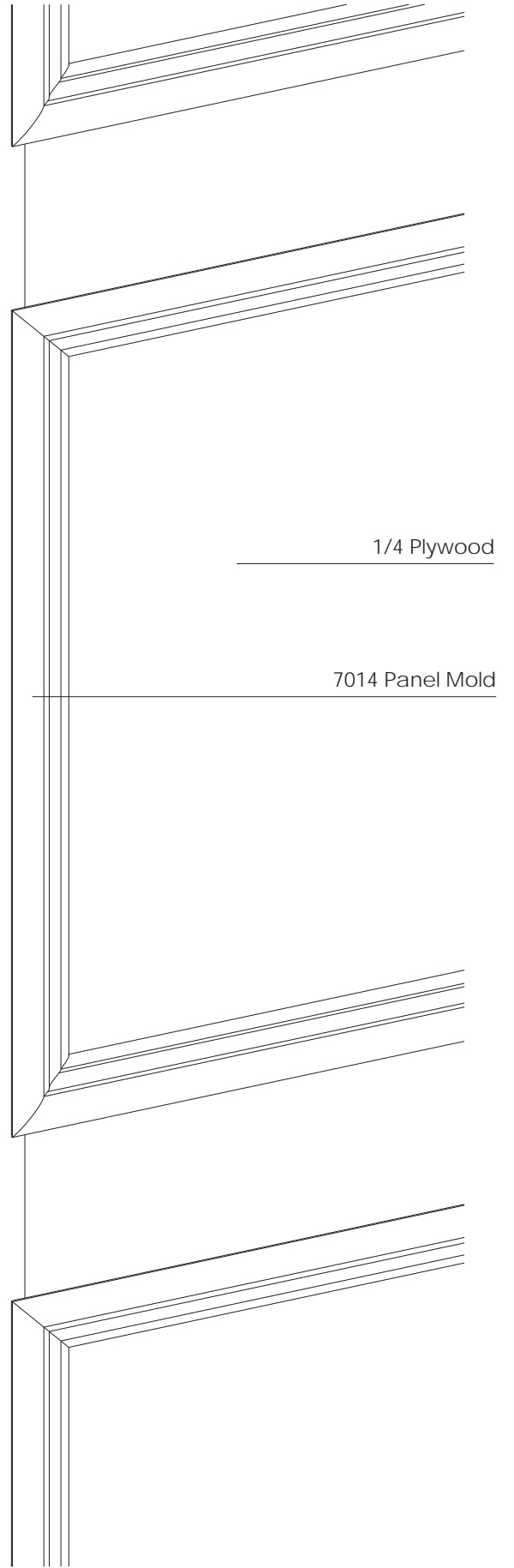
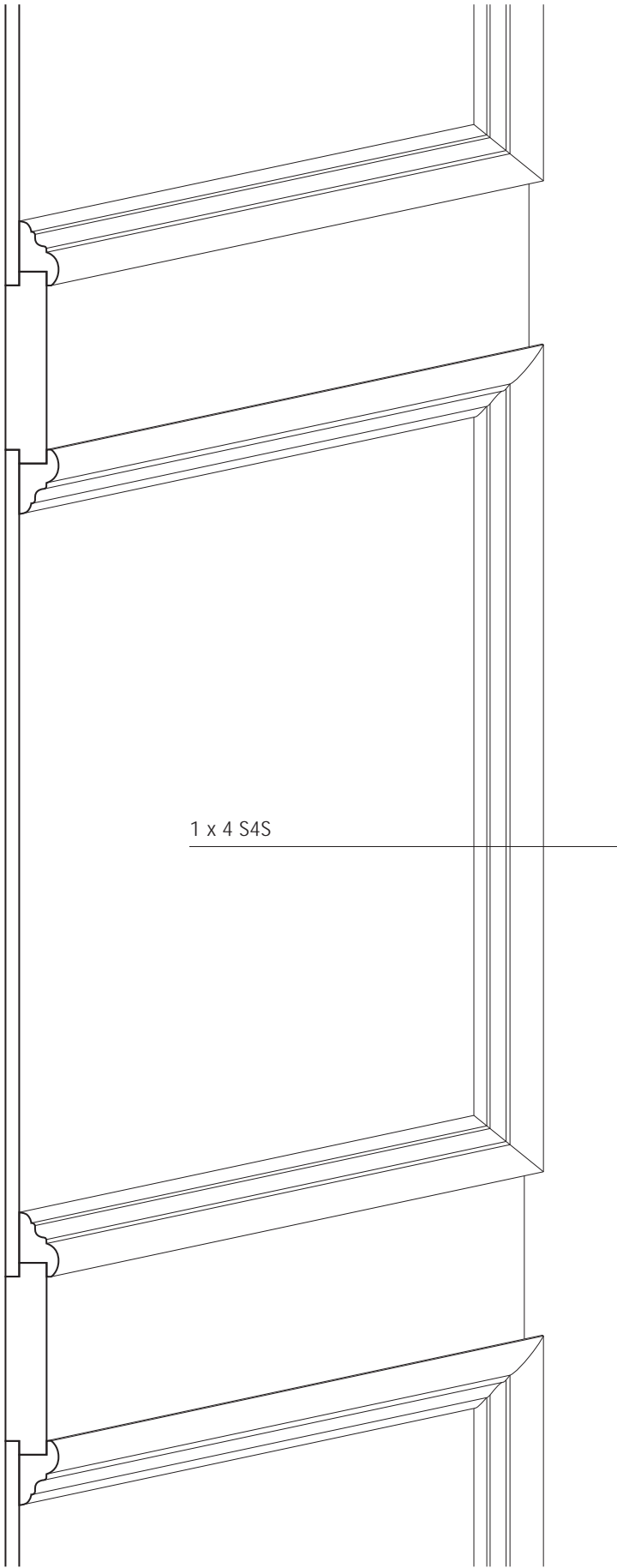

## Wood Column

Wood columns can make a real statement, whether as part of a grand entrance or as a way to divide open spaces.

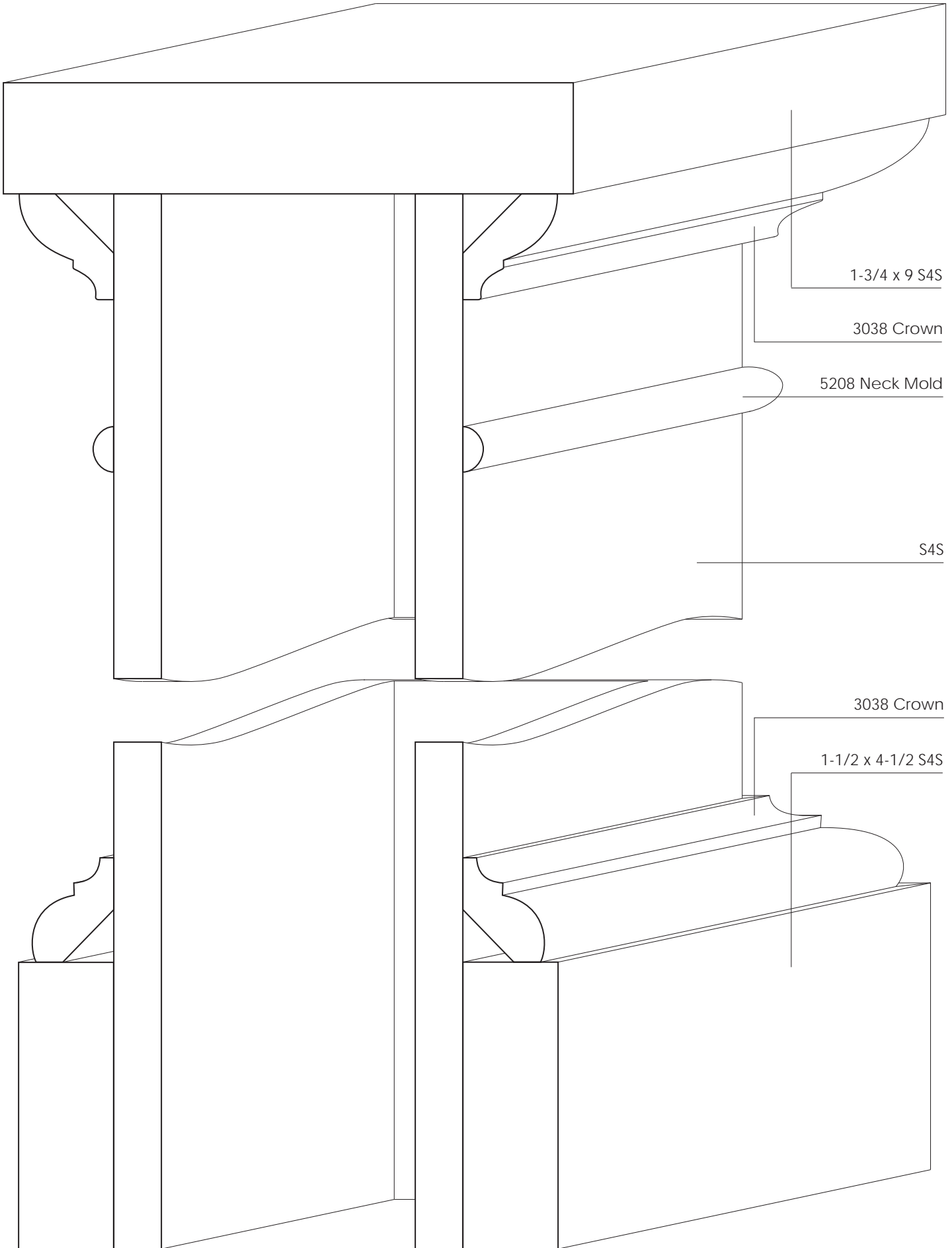

## Entablature

Entablatures, the ornamental superstructure of moldings and bands which lie horizontally above columns, convey formality, elegance, and distinction.

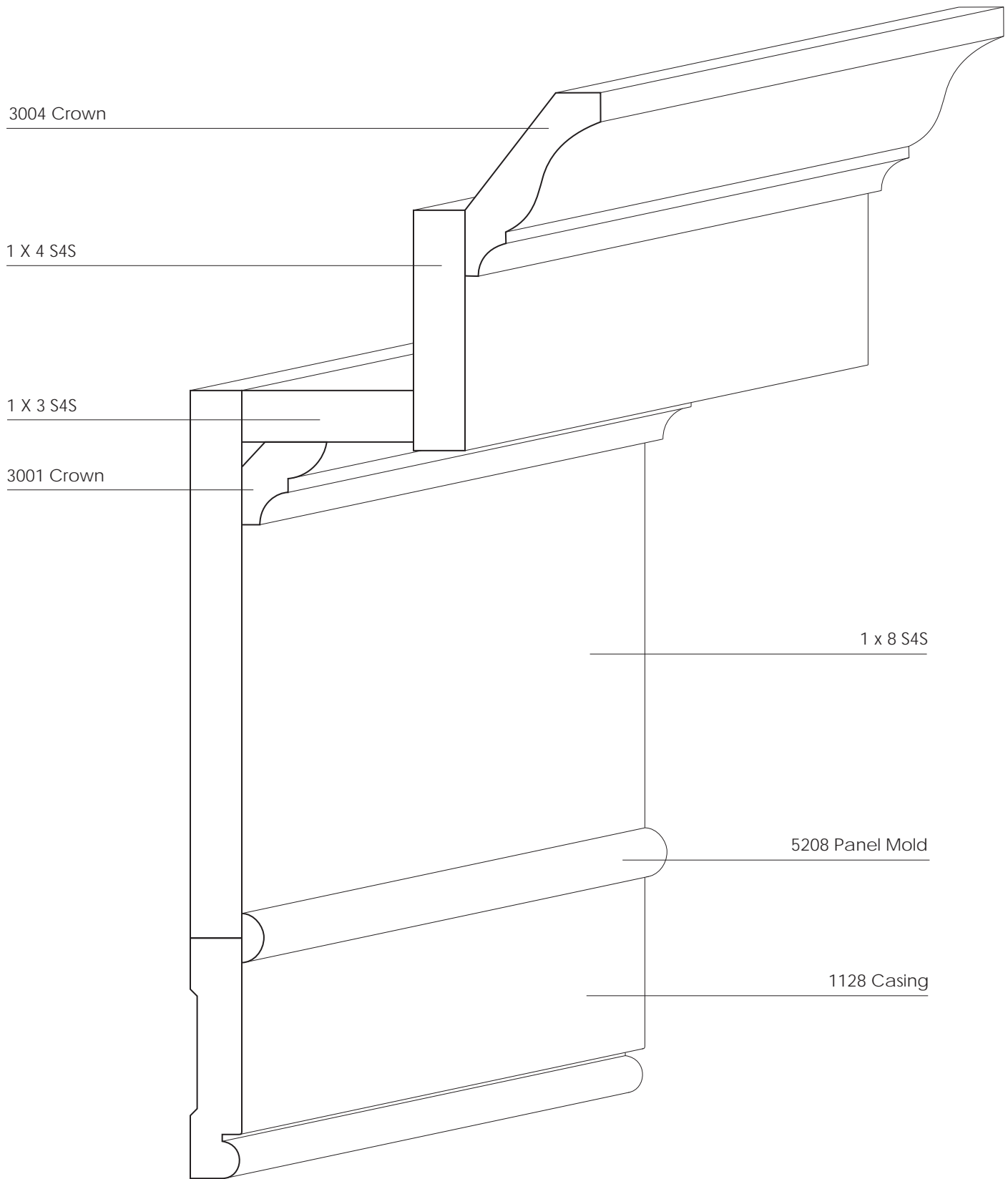

## Door and Window Headers

Headers are horizontal elements of casing or built-up mouldings applied to the top of a door or window opening for added decoration.

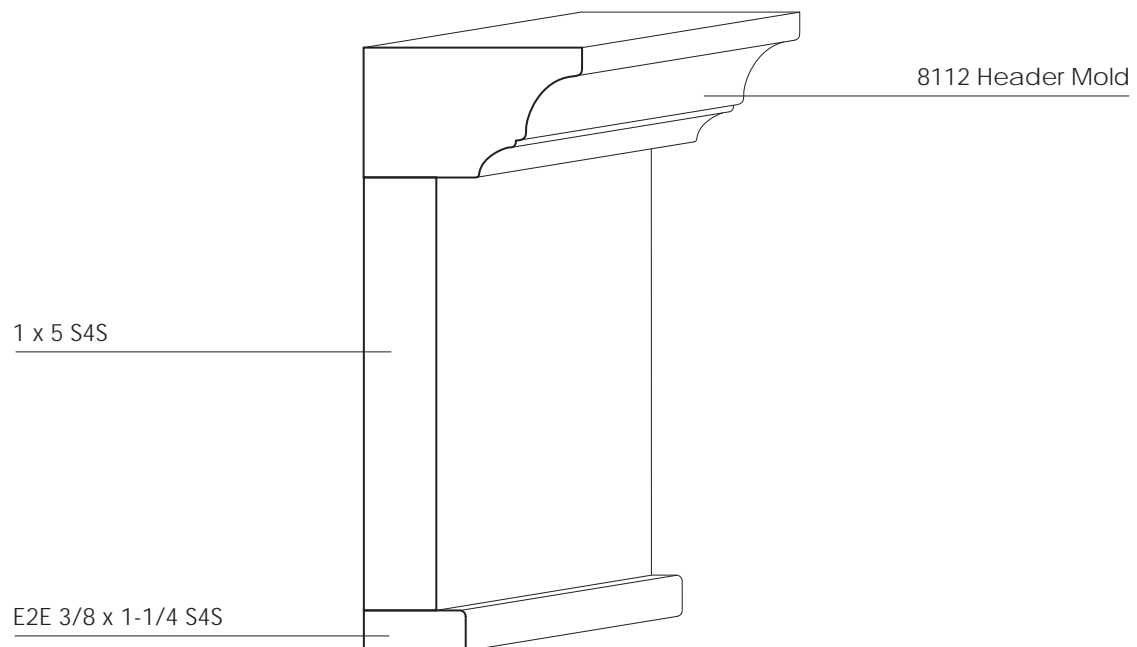
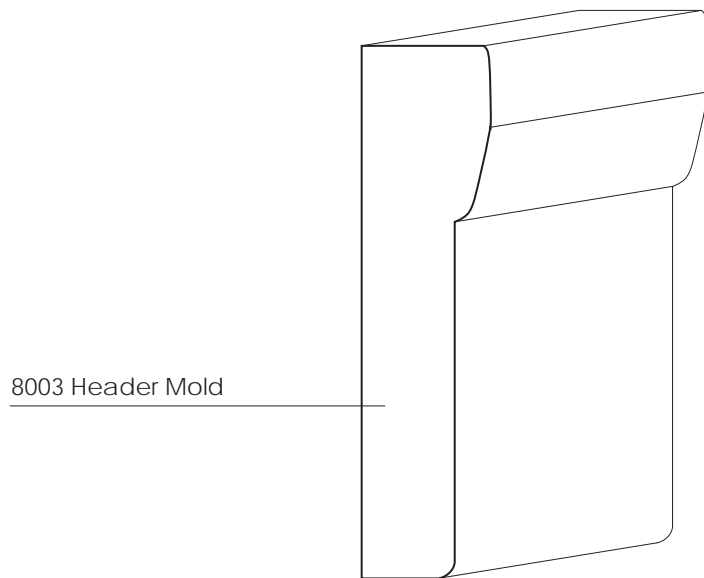

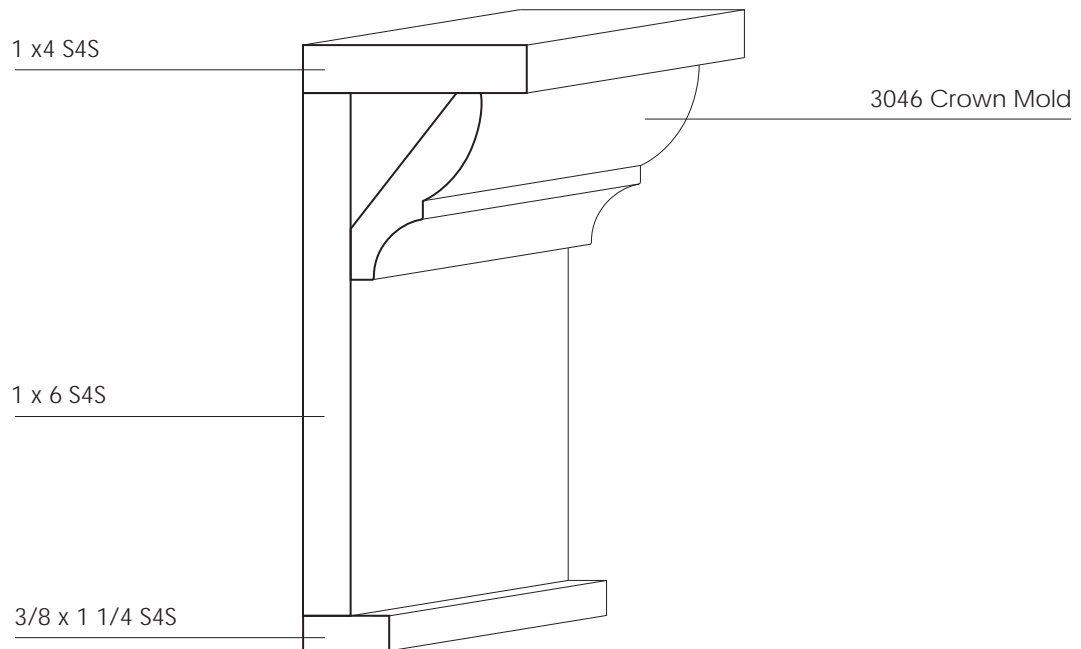
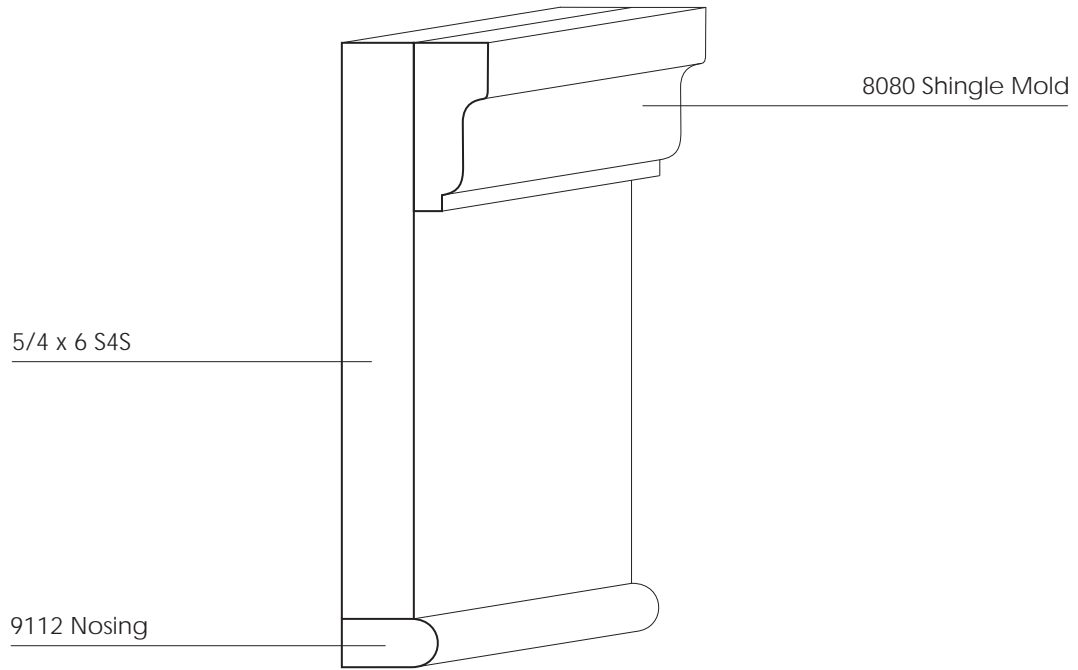

# Casing with Backband

Backband added to casing is a way to make a house look more impressive and creates a "heavy trim" appearance.

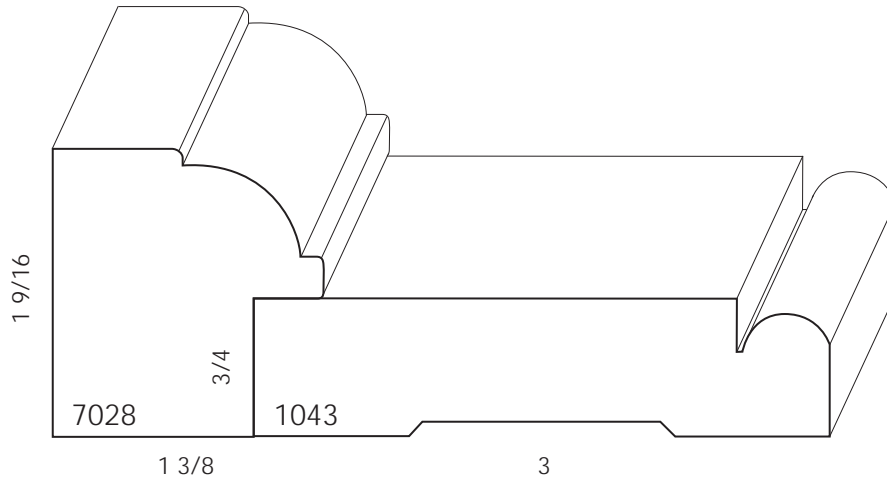

Backband height can be modified to match casing dimensions.

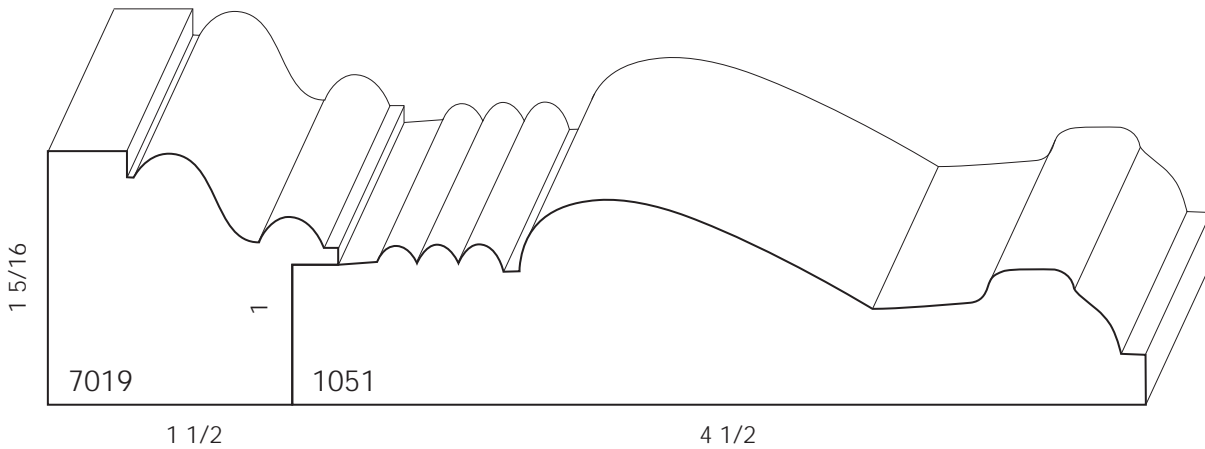
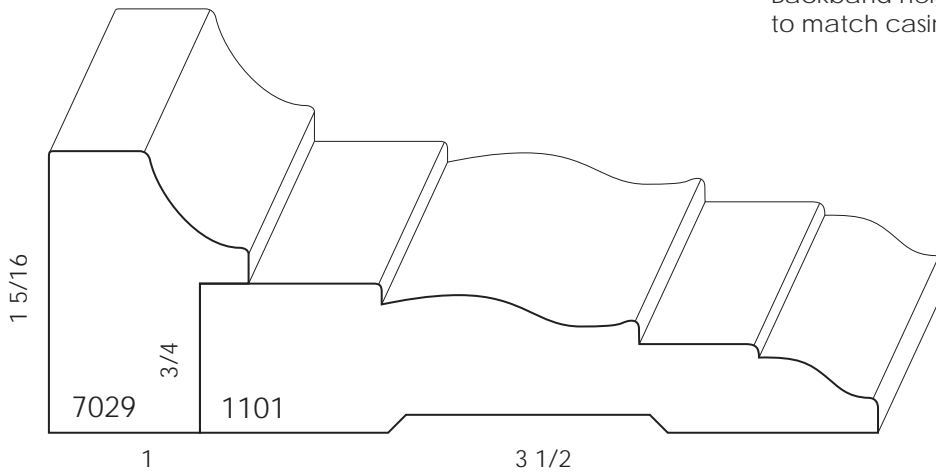

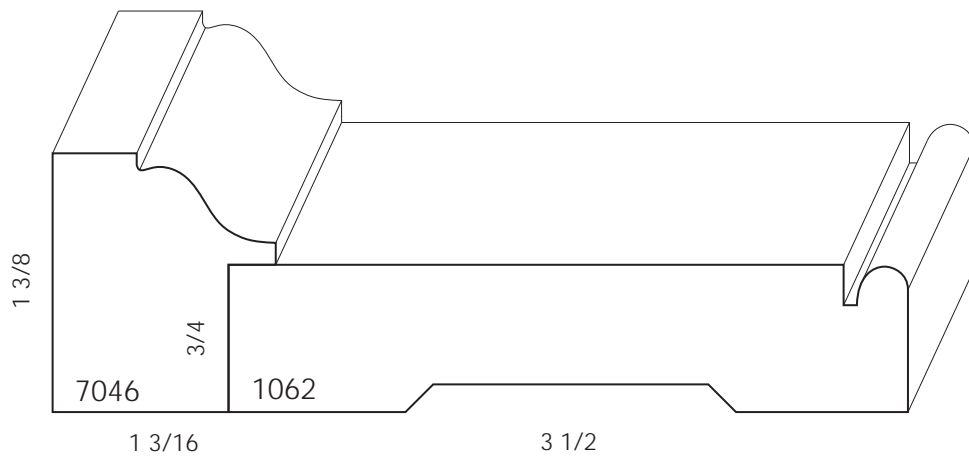
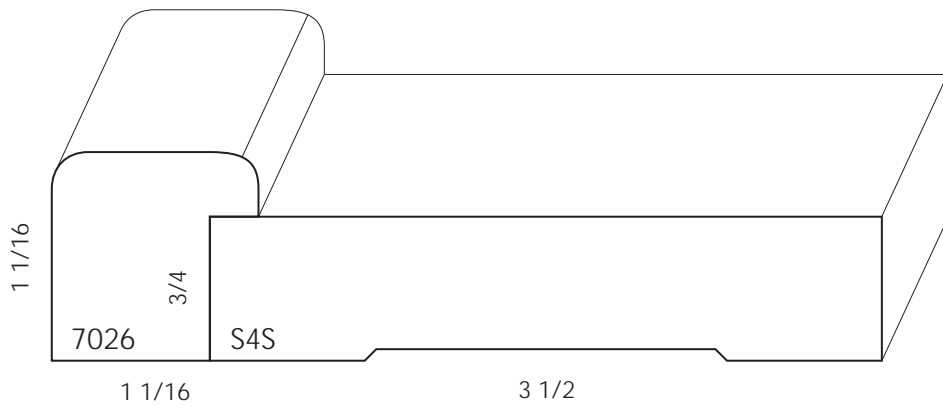
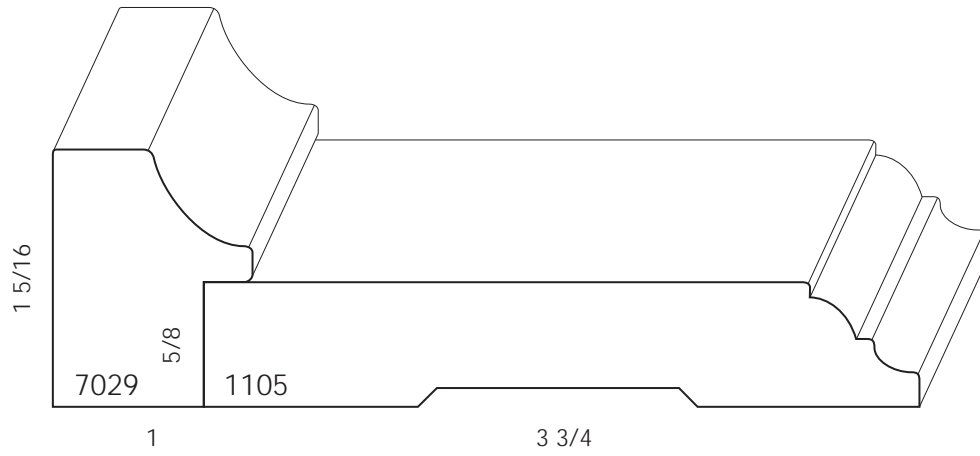
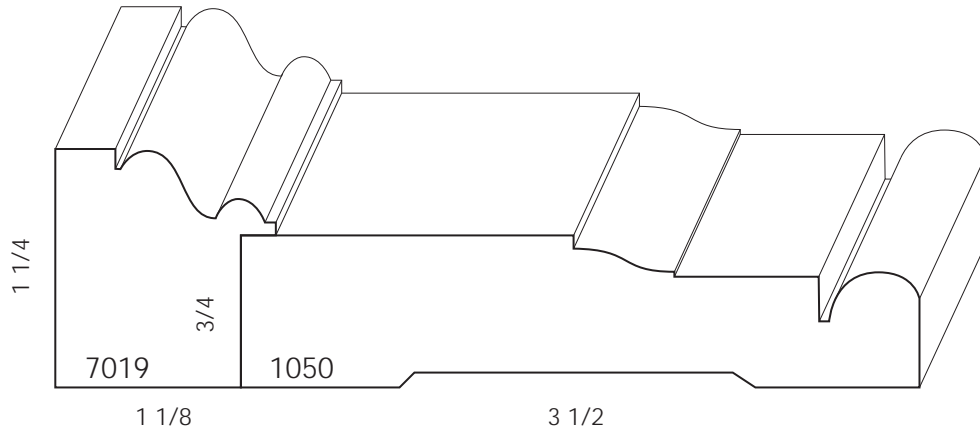

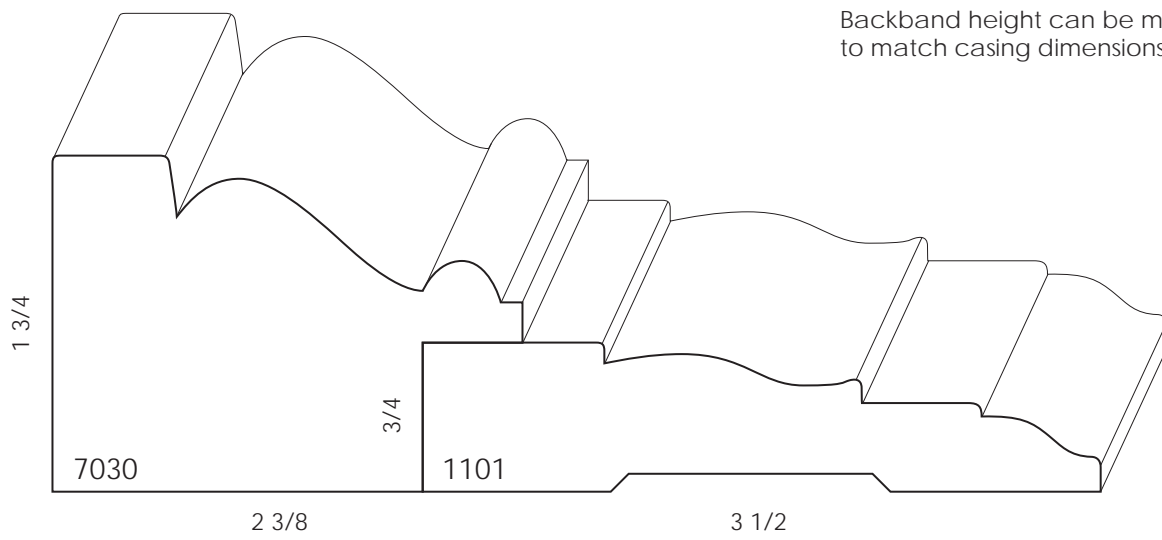
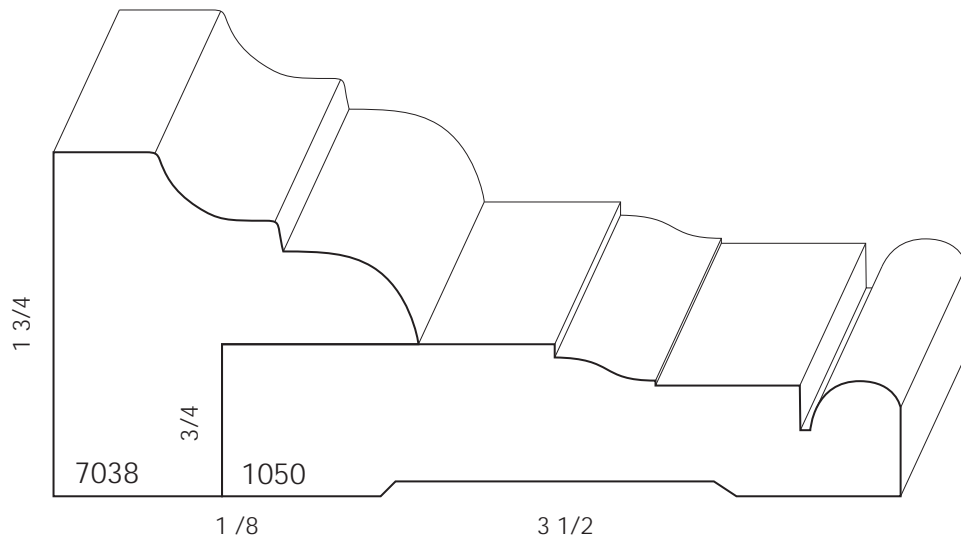
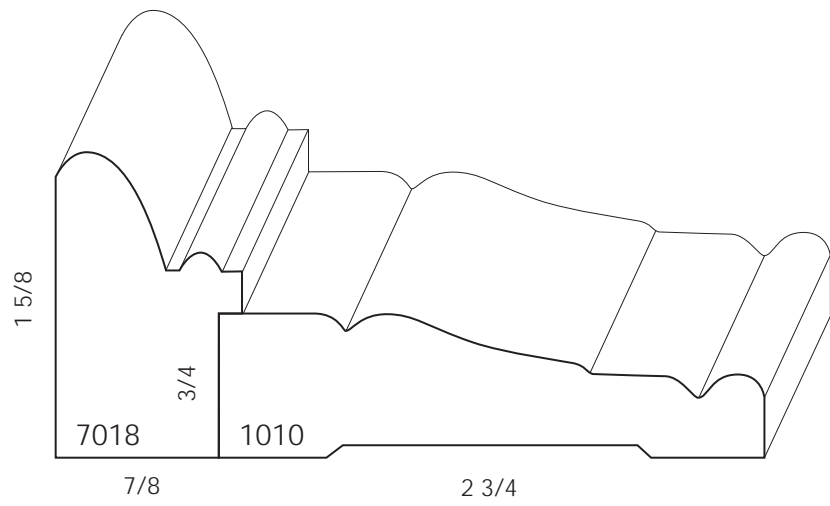

Backband height can be modified to match casing dimensions.

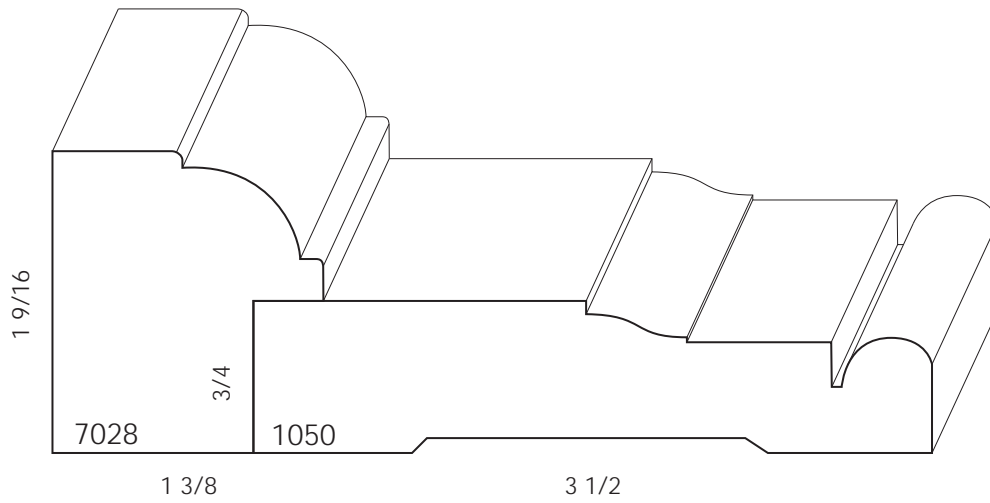
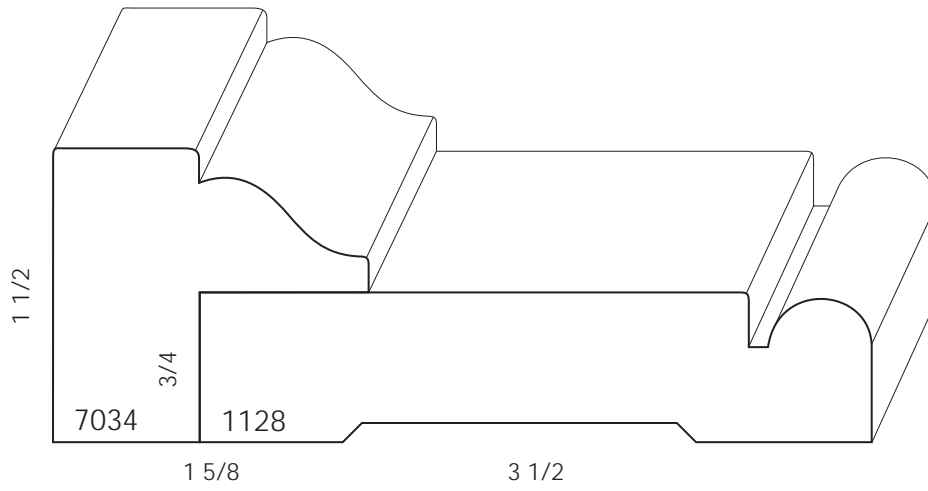
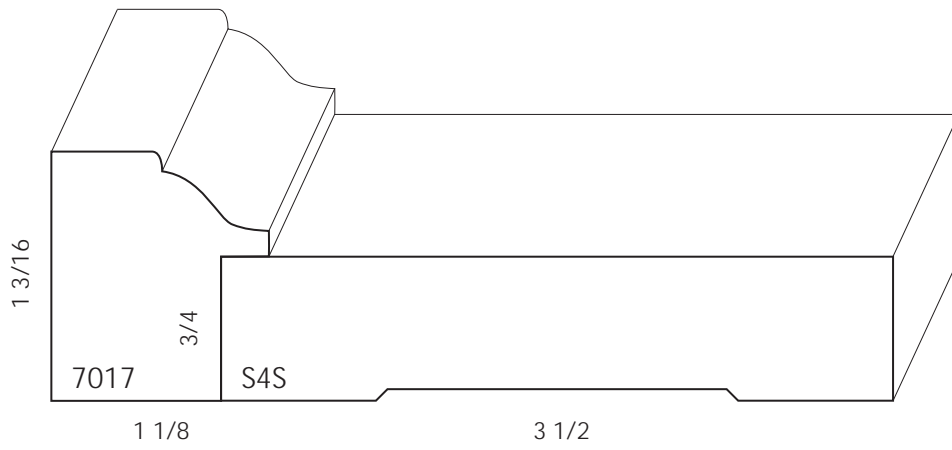

## Custom Order Policies

For all non-stock items, a 10% production charge will be added for all specified lengths.

Orders must be paid upon delivery or pickup unless an account has been set-up.

Custom profiles may be over-run by 10%.

All custom millwork is non-returnable except for the amount that exceeds 10% more than our take-off.

For all non-stock profiles, a set-up charge will be assessed for production runs less than 499 lineal feet. No set-up charge is required for orders exceeding 500 lineal feet.

There is a minimum tooling and set-up charge of \$150 for all new profiles. Tooling charges are based on profile size and complexity.

A deposit is required at the time the order is placed for all custom work.

## Return Policies

A 20% restocking charge will be applied to all returns.

We only accept returns on items that we carry in stock.

All returns must be accompanied by a receipt.

Damaged, soiled, cut, or altered items are not returnable.

Goods are not returnable after 45 days.

Any shortages in orders must be reported within one working day from pick-up or delivery.

Defect items must be returned within 30 days from delivery.

All returns are subject to our approval.

Because wood is a natural product, we are not responsible for variation in color and mineral stains that may occur.

Any defects must be reported before staining, cutting, or installation.

## Warranty policies

Sealing and finishing should be done as soon as possible to maintain wood stability.

All wood products must be maintained under stable temperature and humidity conditions to remain under warranty.

Do not expose wood to rain or snow as water spots could show up after finishing voiding the warranty.

Do not expose wood to extremely high, low, or fluctuating humidity. A relative humidity of 20-60% is ideal.

Wet or damp concrete, plaster, and drywall can transmit moisture to unfinished wood which could lead to swelling, joint separation or warpage and will not be covered under warranty.

Excessive heat, dryness, or sudden temperature changes can cause twisting, cupping, or warping and will not be covered under warranty.

## Shipping policies

Our driver will not carry any material into the house.

All material will be unloaded and placed in the garage.

If the house or garage is locked, please give us the key location or the lockbox combination.

We do not require anyone to be at the delivery site as long as there is access to the garage. If there is no access from the driveway, then we require someone to assist to carry materials from the street.

All material to be returned must be placed in the garage.

UPS shipping and handling charges are non-refundable.

## Glossary of Moulding Terms

Back Band - Rabbeted moulding surrounding the outside edge of casing

Base - Moulding applied where floor and walls meet, forming a visual foundation

Base Cap - Decorative moulding installed flush against the wall and top of an S4S baseboard

Cased Opening - An interior opening without a door that is finished with jambs and trim

Casing - Moulded or surfaced-four-sided pieces of various widths and thicknesses for trimming out door and window openings

Corner Blocks - Square blocks used in place of mitering the sides and head casing

Cove - Moulding with a concave profile used at corners, particularly as a ceiling cornice

Chair Rail - Wooden moulding placed along the lower part of the wall to prevent damage

Crown - Highest part of built-in or wall, often above eye level, usually the upper trim on interior walls

Dentil Block - A smaller rectangle block which can be spaced closely together in a series or in sequence with moulding and projecting like teeth as used in cornice, front entrances and mantels, and crossheads

Door Stop - Moulding nailed to faces of the door frame to prevent the door from swinging through

Entablature - The superstructure of moldings and bands which lie horizontally above columns, resting on their capitals

Hand Rail - Hand support in a stairwell

Jamb - Top and two sides of a door or window frame

Mouldings - Ornamental strips used to decorate a surface, often used to accent or emphasize the ornamentation of a structure and to conceal surface or angle joints

Nosing - Rounded edge of a stair step

Panel Mold - a decorative pattern, originally used to trim out raised panel wall construction. Most useful fabricated as a frame, surrounding attractive wall coverings for a paneled effect on walls

Rosette / Plinth Block - Rosette is a decorative block in the upper corner of windows and doors. Plinth is the base block which is placed on both sides of the door resting on the floor

Shoe Rail - Primarily used for closed stairs with a curb wall. The shoe rail sits on top of the curb wall and the balusters fit inside the shoe rail. The fillet is cut and pieced between the balusters

Shoe Mold - Quarter round trim applied at the bottom of baseboard where it meets the floor

Tongue & Groove - Lumber machined to have a groove on one side and a protruding tongue on the other side, so that pieces fit snugly together with the tongue of one fitting into the groove of the other

Wainscoting - Lower interior wall surface (usually 3 to 4 feet above the floor) that contrasts with the wall surface above it

Window Sill - Interior trim member serving as a window frame sill cap

## Further Reading

The reading list shown below is far from exhaustive. We recommend visiting the bookshop at [classicist.org](http://classicist.org) or visiting your local bookstore for additional architectural and historical insight and information.

1. A. J. Bicknell & Co, ed. *Victorian Architectural Details: Designs for Over 700 Stairs, Mantels, Doors, Windows, Cornices, Porches, and Other Decorative Elements*. Mineola.: Dover Publications, 2005. Print.
2. Benjamin, Asher. *The American Builder's Companion: Or A System Of Architecture, Particularly Adapted To The Present Style Of Building* (1816). Whitefish: Kessinger Publishing, 2010. Print.
3. Benjamin, Asher. *The Architect, or Practical House Carpenter* (1830). Mineola: Dover Publications, 1989. Print.
4. Cigliano, Jan, and George E Hartman. *Pencil Points Reader: Selected Readings from a Journal for the Drafting Room, 1920-1943*. New York: Princeton Architectural Press, 2004. Print.
5. Hull, Brent. *Historic Millwork: A Guide to Restoring and Re-creating Doors, Windows, and Moldings of the Late Nineteenth Through Mid-Twentieth Centuries*. Hoboken: Wiley, 2003. Print.
6. Hull, Brent. *Hull Historical Molding*. East Petersburg: Fox Chapel Publishing, 2008. Print.
7. Mudrick, MaryBeth, and Lawrence D Smith. *Federal Style Patterns 1780-1820*. Hoboken: Wiley, 2005. Print.

8. Semes, Steven W. *The Architecture of the Classical Interior*. New York: W. W. Norton, 2004. Print.
9. The Mulliner Box & Planing Co, ed. *Turn-of-the-Century Doors, Windows and Decorative Millwork: The Mulliner Catalog of 1893*. Mineola.: Dover, 1995. Print.
10. Universal Catalog Bureau, trans. *Universal Millwork Catalog, 1927: Over 500 Designs for Doors, Windows, Stairways, Cabinets and Other Woodwork (Dover Pictorial Archives)*. Mineola: Dover, 2003. Print.
11. Walker, C Howard. *Theory of Mouldings*. New York: W. W. Norton, 2007. Print.



Ensure proper balancing  
procedures when using  
this tool. Refer to Vring  
operation instructions.





P.O. Box 15 or 13813 Station Road; Burton, Ohio 44021

440.834.1891 or 800.798.1269 fax 440.834.1893

Monday-Friday 8am-4:30pm, Saturday 8am-12pm

[www.mouldingsone.com](http://www.mouldingsone.com)